

DYNACO

SUPER FIDELITY *
OUTPUT TRANSFORMERS



For unequalled listening pleasure

T0668

• LICENSED UNDER U. S. PATENT NO. 2,615,408

dynaco inc. 3060 Jefferson St., Philadelphia, Pa. 19121 U.S.A.

DYNACO

SUPER FIDELITY
OUTPUT TRANSFORMERS

The new line of DYNACO output transformers incorporates the first basic advance in output transformer design since the introduction of interleaved windings. All DYNACO models feature para-coupled windings, a design by David Hofter on which patents are pending. This novel arrangement provides an accurately balanced coil with tight coupling between the various sections and a choice of parameters which furnish superior quality at moderate cost. The low distortion which results from the para-coupled design gives greater definition of musical detail—analogue to the way in which complex coupling of lens elements can provide greater resolution of photographic detail.

The basic aim in the design of DYNACO transformers was to provide the finest possible performance under actual audio operating conditions as well as under steady state laboratory test conditions. This goal was achieved by building into the transformers a large margin of performance capabilities, over that normally expected in an output transformer. One result of this policy is that the design is not critical on tube balance, and circuits can be simplified and maintenance minimized by omission of components which are used solely for the purpose of balancing currents in the output transformer.

Recognition of the important fact that output transformers are intended to operate with loudspeaker loads rather than resistive loads alone led to design features which preserve the quality of performance even when the load impedance shifts such as happens at the ends of the audio spectrum with loudspeaker loads. The substantial reserve of power handling capability which is built into every DYNACO Super-Fidelity output transformer permits full undistorted power transmission at frequency extremes. Most better grade transformers can deliver a reasonable amount of power in the middle of the audio band. Unfortunately however, in most units the distortion at high levels increase sharply at the ends of the band. This is not true for DYNACO transformers since the para-coupled arrangement reduces middle and high frequency distortion, while a massive core of thin gauge grain oriented steel provides distortionless transmission of high level, low frequency signal components.

Modern high fidelity amplifier circuits incorporate substantial proportions of negative feedback, primarily to reduce distortion to extremely low levels. However, there is a penalty which is incurred in the use of large amounts of feedback—problems of instability are introduced, and a large part of these problems are due to the detrimental phase characteristics of the output transformer used. Amplifiers which do not have sufficient margin of stability under feedback conditions tend to get "bloopy" and muddy at low frequencies and harsh and strident at high frequencies. The remedy requires close control of the amplifier and transformer phase characteristics even at frequencies far removed from the audio band.

Advanced pulse techniques have been incorporated into the design and production of DYNACO Super-Fidelity transformers to make the phase characteristics suitable for amplifiers with high proportions of feedback. The gain in margin of stability which accrues from this design

technique makes an audible improvement in listening quality. The best test for inherent stability under feedback conditions is the use of the square wave test—both on the transformer alone and on the complete amplifier with loudspeaker load. The superiority of DYNACO transformers is readily confirmed in this square wave test by noting the straight sides and flat top of the waveform and the absence of ripples and spikes, even at high frequencies.

DYNACO Super-Fidelity transformers are built to give consistent, long lasting performance. Such features as 3000 volt insulation, vacuum impregnation, high temperature potting compound, and rigorous production testing protect the performance obtained by unique design and precision winding. The design, the materials, and the fabrication are the finest available; and they provide the finest performance.

CIRCUITS FOR DYNACO TRANSFORMERS

The high performance capabilities of DYNACO Super-Fidelity transformers will improve any circuit in which these transformers are used. As a general rule they can be inserted in any high quality circuit configuration including "Williamson," "ultra linear," "multi-loop," or any other with gratifying improvement in amplifier stability and distortion characteristics. However, the benefits available from a given transformer are bounded by the circuit in which it is used. Therefore, we recommend some specific circuit arrangements which have been carefully designed and tested to insure maximum user satisfaction.

The circuits shown are suggested for "those who roll their own," either in complete amplifier construction or in modernization and conversion of older equipment or moderate-fidelity commercial equipment.

The DYNACO circuit, as used in the DYNAKIT Mark III, was designed to match the outstanding characteristics of the A-431 transformer. The simplicity, stability, and quality of this circuit are unequalled by any regardless of complexity or cost.

The thousands of people who have Williamson type amplifiers, in any of the popular versions, can now modernize them to improve the amplifier stability characteristics and to increase their power output to over 50 watts as shown in figure 2. This modernization and conversion, using the DYNACO A-431 transformer, makes an improvement in quality which is audible even to the untrained ear since there is greater cleanliness and smoothness of the sound.

Figure 3 illustrates a low power circuit (12 watts at less than 1% THD distortion) which is similar to that used in many of the medium priced commercial amplifiers. Either EL-84's or tubes of the 6V6 and 6AQ5 type can be used in this configuration with the A-410 transformer. The use of this super-fidelity transformer in commercial grade equipment makes a substantial improvement in transient response as well as drastically lowering the distortion. Most commercial amplifiers can be greatly improved merely by direct substitution of the A-410 for amplifiers of the 6V6 type or the A-420 for amplifiers of the 58B1, 6L6, and KT-66 type without any other circuit changes.

The 120 watt A-441 transformer is designed specifically to be used in applications requiring a tightly coupled tertiary winding for screen feedback, cathode loading, or for balanced feedback to earlier stages. With 6550 tubes using 600 plate volts, 350 screen volts, and 35 volts of fixed bias, it is practical to get 100 watts of clean output with superb listening quality. The output stage can be readily driven from Williamson type circuits of the modernized type.

FIGURE 3

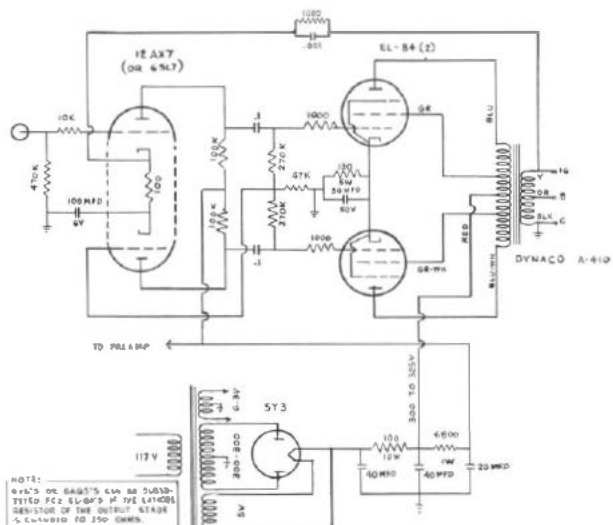

LOW POWER HIGH QUALITY CIRCUIT WHICH CAN BE USED TO IMPROVE THE QUALITY OF COMMERCIAL AMPLIFIERS

FIGURE 4

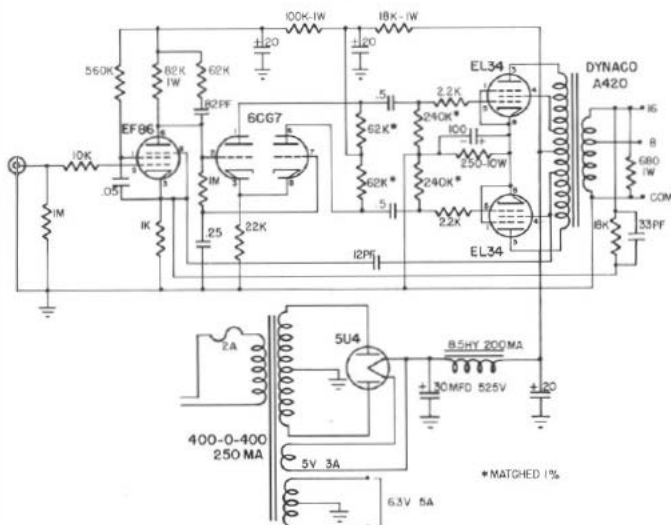

IMPROVED MULLARD 30 WATT AMPLIFIER USING DYNACO A-420 TRANSFORMER

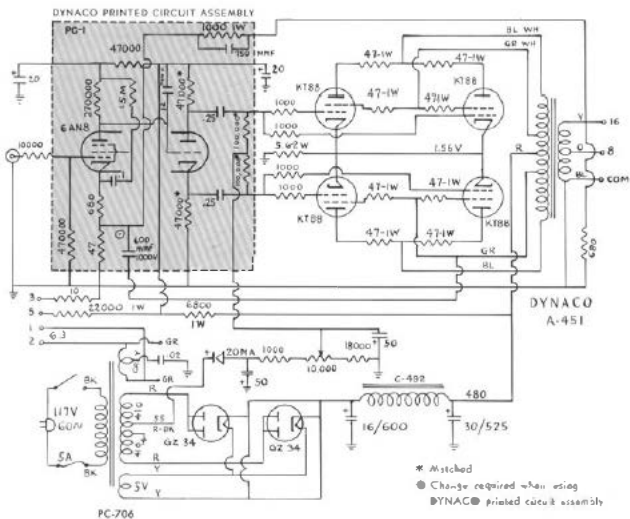

DYNACO 120 WATT AMPLIFIER USING DYNACO A-451 TRANSFORMER

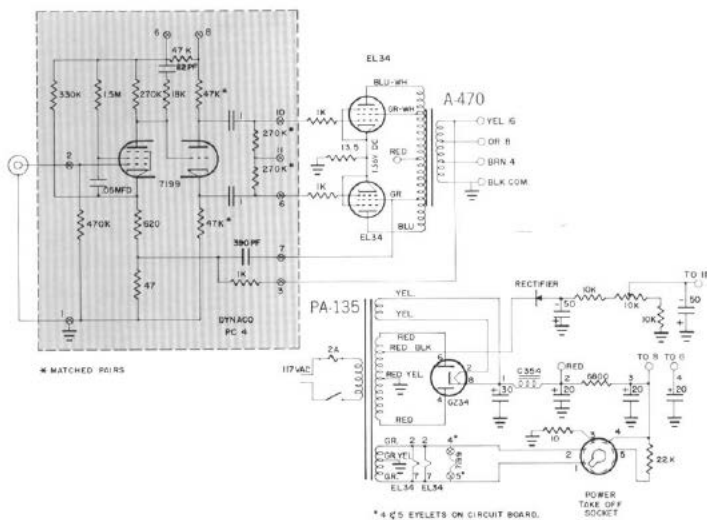

DYNAKIT MARK IV 40 WATT POWER AMPLIFIER

DYNAKIT STEREO 70 DUAL 35 WATT POWER AMPLIFIER

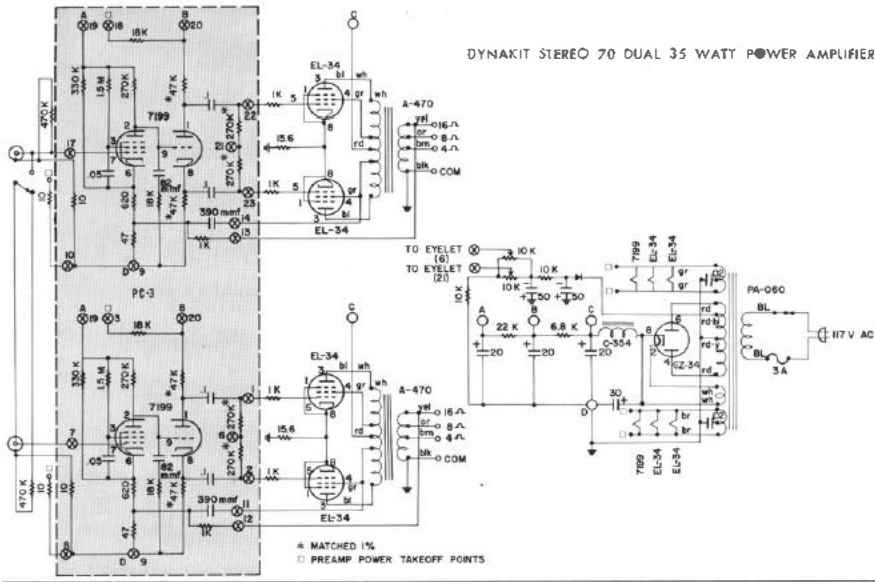

FC-6

PC-5

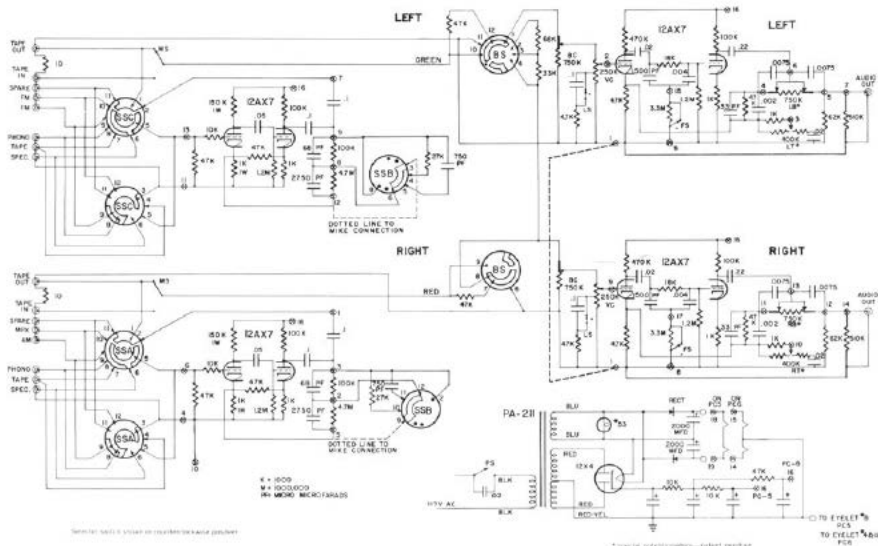

DYNAKIT PAS-3X STEREO PREAMPLIFIER

DYNACO

SUPER FIDELITY OUTPUT TRANSFORMERS

	A-410	A-420	A-431 [†] A-431-70 [†] A-430-100 [†]	A-441	A-451	A-470
Impedance ratio	8000 ohms ct to 8, 16 sec	6600 ohms ct to 8, 16 sec	4300 ohms ct to 4, 8, 16 sec [†] to 4, 8, 16 and 70V [†] to 125Ω or 500Ω [†]	4200 ohms ct to 4, 8, 16 sec	2200 ohms ct to 4, 8, 16 sec	4300 ohms ct to 4, 8, 16 sec
Undistorted power: 30 cps to 15 kc 20 cps to 20 kc	30 watts 15 watts	60 watts 30 watts	120 watts 60 watts	240 watts 120 watts	240 watts 120 watts	70 watts 35 watts
Minimum frequency response	± 1 db @ cps to 60 kc	± 1 db @ cps to 60 kc	± 1 db @ cps to 60 kc	± 1 db @ cps to 60 kc	± 1 db @ cps to 60 kc	± 1 db @ cps to 60 kc
Size (inches)	2-7/8 x 3 x 3-3/8 high	3-3/4 x 3-1/2 x 4-1/2 high	4 x 4-5/8 x 5 high	5-7/8 x 4-3/4 x 6 high	5-7/8 x 4-3/4 x 6 high	3-3/4 x 3-1/2 x 4-1/2 high
Mounting centers (inches)	2 x 2	2-3/4 x 2-1/4	2-3/4 x 3-7/8	4 x 3-1/2	4 x 3-1/2	2-3/4 x 2-1/4
Weight	5 lbs.	7 lbs.	14 lbs.	24 lbs.	23 lbs.	7 lbs.
Application	6V6's, EL-84's, 6AQ5's	KT-66's, 5881's, EL34's, or 6CA7's <small>(SEE WIREBOARD CIRCUIT)</small>	650B's, KT-88's, EL34's, or 6CA7's see par KT-66	650's or KT-88's in PP-41's up to 100-ohm output or 1-ohm + in-coupling filter or either 650B's or 650B's feedback, see par EL-84's or 6CA7's in PP-41's up to 700 ohms	↑apper 650B's, KT-88's, EL34's, or 6CA7's	EL34's, or 6CA7's see par EL84's
Net Price (Slightly Higher in the West)	\$20.95	\$28.95	\$39.95 [†] \$46.95 [†] \$44.95 [†]	\$59.05	\$39.95	\$26.95

All units have taps on primary windings except A-451 which has tightly coupled tertiary winding.

All units are furnished in heavy gauge steel cans with 12" color coded leads and steel mounting studs with mounting hardware.

Units are conservatively designed and can handle twice the dc current of the tube types recommended for use. Neither overloads nor any amount of unbalanced operation will harm the transformers. For optimum low distortion reproduction, the dc balance should be kept within 10%.

P-782 power transformer as used in Dynakit Mark III 410. -55 410, 200 ma; 5v, 3v, 6.3v, da. Weight 9 lbs.; size 4" x 4 1/2" x 4 1/2" high; net price \$20.00. (Furnished only in vertical mounting and shall construction).

PC-706 power transformer for use with A-451 in 120 watt amplifier circuit: 410-0-55-410, 400 ma; 5v, 6v, 6.3v, 8v. Weight 14 lbs. Net price \$33.00. (Furnished in vertical end shells only).

C-354 choke (200 ma) Net price \$2.80

C-492 choke (400 ma) Net price \$6.60

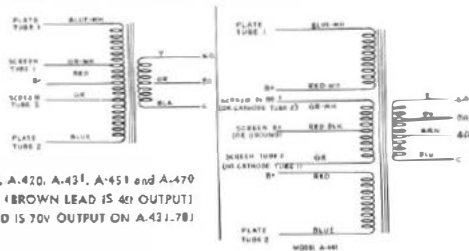

MODELS A-410, A-420, A-431, A-451 and A-470
(BROWN LEAD IS 60V OUTPUT)
(WHITE LEAD IS 70V OUTPUT ON A-431-781)

