



COIN MECHANISMS INC.

Where The Money Meets The Machine

PO Box 5128, 400 Regency Drive, Glendale Heights, IL 60139-5128 VOICE: 630/924-7070 1-800-323-6498 FAX: 630/924-7088

**DOCUMENT NO. 09300083
SEPTEMBER 27, 2001 Rev. 3**

DETAILED PROCEDURE FOR AIR BALANCING COMPARITOR SENSOR COILS WITH OSCILLOSCOPE

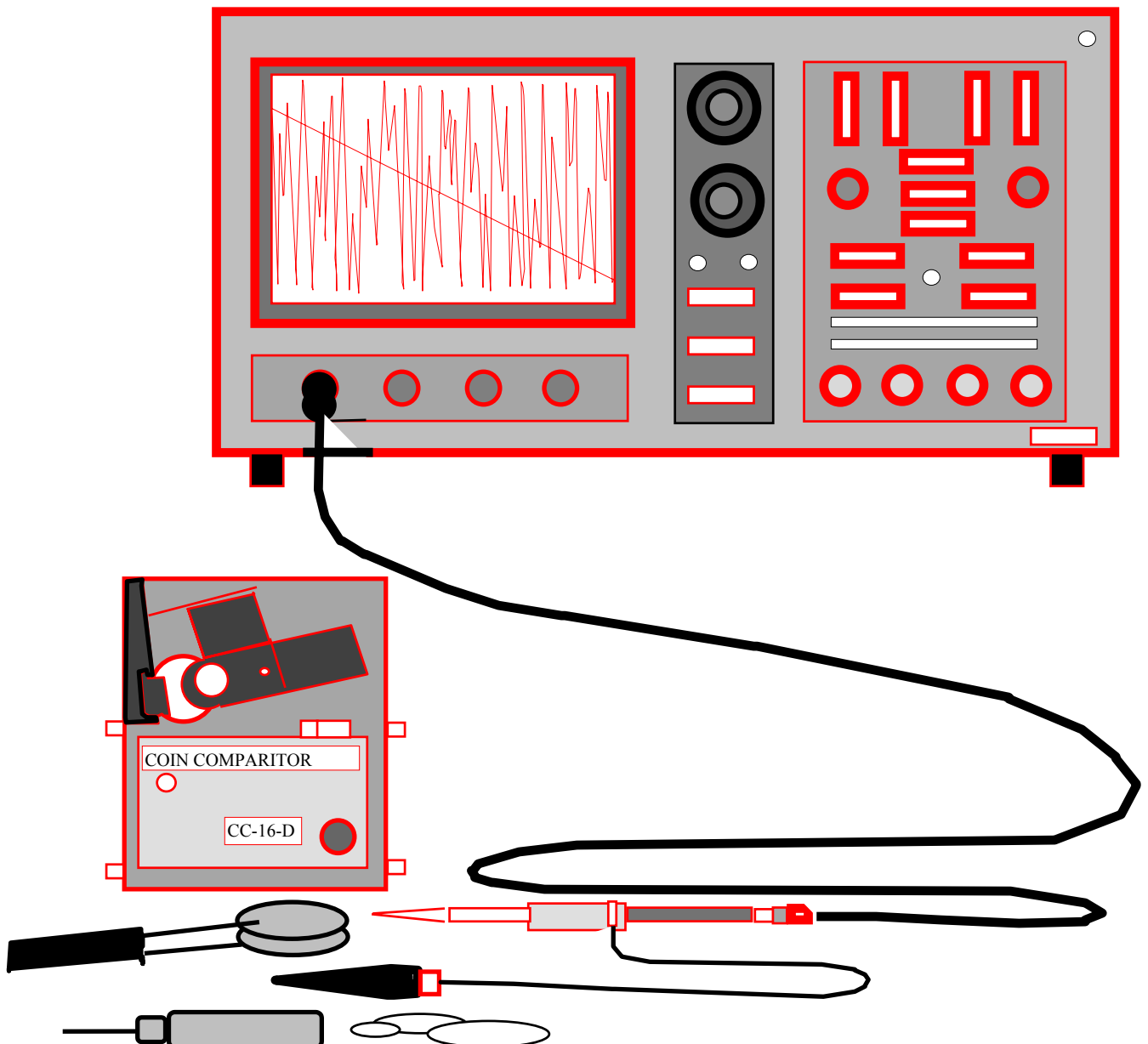

DETAILED PROCEDURE FOR AIR BALANCING THE SENSOR COILS WITH OSCILLOSCOPE

INTRODUCTION:

Air balancing the sensor coils is one of the most important adjustments made to the Coin Comparitor. Air balancing simply means to adjust the gap between the coils, to create an electrical field that is equal in both coin slots. It is important to adjust both coil sensor screws on the CC product line to an equal depth into the sensor coil body. By following this procedure, a uniform chamber gap will be maintained in the sensing area. Coin travel and sensing metal content of coins and tokens can be made more accurately. In addition, proper rail insert adjustment will complete the air balance procedure by providing a means to match the resident coin to the falling coin so they "eclipse" in the sensor coils. There is no rail adjustment on the Intelligent Comparitor product line.

Another performance related adjustment is the selectivity potentiometer. Proper selectivity adjustment will improve coin / token acceptance vs. slug rejection.

Pages 10 – 13 illustrates the input/output pin assignments for the various Coin Comparitors that **COIN MECHANISMS INC.** manufactures.

WHY AIR BALANCE THE SENSOR COILS ?

- 1) After installing a new sensor coil assembly into a Comparitor.
- 2) After installing a rebuilt sensor coil assembly into a Comparitor.
- 3) Typical maintenance procedure for optimum performance.

ACCESSORIES

The following are accessories available from Coin Mechanisms Inc. or our authorized distributor for powering your unit or assist in testing and/or adjusting a Coin Comparitor.

PART NUMBER	DESCRIPTION
05000009	Test Stand (See page 10 OF 19)
09280101	I/F,B,TS,COMPARITOR,3PIN JST,BLK/VIO/ORG
09280100	I/F,A,TS,COMPARITOR,6PIN JST, BLK,ORG,YEL, RED, BLU GRY
09280103	I/F,D,TS,COMPARITOR,7PIN MOLEX/AMP,YEL/RED/BLU /ORG/GRN/BLK
09280102	I/F,C,TS,COMPARITOR,6PIN MOLEX/AMP GRY/RED/BLU/YEL/ORG/BLK
09300247	VIDEO,VHS,COMPARITOR TRAINING
09300256	VIDEO,PAL,COMPARITOR TRAINING

TOOL LIST:

- 1) Various diameter, plastic tokens.
- 2) 1/16" hex allen head, adjusting screwdriver.
- 3) Coin sticks, or coins and scotch tape.
- 4) **Comparitor Test Station**, or power supply.
- 5) Oscilloscope, optional if using **the Comparitor Test Station**.

AIR BALANCING PROCEDURES FOR THE COIN COMPARITOR AND MICRO COMPARITOR

Preliminary setup:

- 1) Connect scope test probe to the "Test Point", (see pg.14 - 19). Illustrations show a CC-16, CC-40, CC-46/MC, CC-62, CC-33/37, CC-32/36 Comparitors and Intelligent Comparitors for "Test Point" location = pin 7 op-amp output. IC model is shown on pages 18 and 19. Refer to individual Mech Control PCB documentation (Schematic Diagram) for "Test Point" location and (Voltage Spec Sheet) for power input to Comparitor models. Ground the scope ground connection to the ground input for common ground. If using the Comparitor Test Station connect a test lead from the *Mech Test Point* to the "Test Point" on the PCB (refer to document #00300001 Comparitor Test Station User Manual).
- 2) Set the Scope VOLT/DIV. to 500 mv. per division.
Set the Scope TIME/DIV to 1 ms. per division. Depending on type of scope, some waveform positioning may be necessary to view the whole waveform.

Air Null Balance setup :

- 1) Use the plastic token chip provided with Comparitor (similar in diameter) to the actual coin or token to be used later as the sample coin and insert this chip into the sensor coils "Sample Holder", indicated by the label "Slide To Replace Coin". The plastic token positions the coils in their optimum location to simulate typical operating conditions. (see FIG. 2).

For optimizing performance:

- 2) Using the 1/16" allen head screw driver, back out the sensor coil screws counter-clockwise approximately two full turns. Check the *Coil Mounting Screw* holding the sensor coils together for approximately 4-in. lb. of torque. Torque this screw to 4-in. lb. if necessary then seat the allen screws as indicated in step 3. (See FIG.4).

For new or rebuilt sensor coil assemblies:

- 3) Using the 1/16" allen head screw driver, turn the *Sensor Coil Adjusting Screws* clockwise (see FIG. 3) until screws **just** touch against the center coils metal plate stop. Make sure both screws are seated with equal depth into the sensor coil body.

Air Null Balance adjustment :

- 1) Start with top screw first and alternate between top and bottom screws in short intervals, with inward clockwise rotation, until achieving the smallest amplitude of the waveform possible. Typically 80 to 200 mv. is considered to be a proper null. If using the Comparitor Test Station, achieve the lowest μA reading on the μA meter. (refer to document #00300001 Comparitor Test Station User Manual).

Rail Insert adjustment setup:

- 1) Remove the plastic chip token from the "Sample Holder". Insert "Coin Sticks" into the coils, using the allen screw driver turn the rail insert screw counter-clockwise until rail insert is against the rail body, remove any slack in the assembly by applying light pressure against the coils, towards the rail assembly (see FIG 4 & 5).
- 2) If "Coin Sticks" are unavailable use the coin and tape method, insert coin into the "Sample Holder", remove slack, apply tape to second identical coin and lower it into the other coil gap, position the taped coin in parallel to and "eclipse" the sample coin, observe the waveform for lowest amplitude and tape coin in place onto the mainplate.

Rail Insert adjustment:

- 1) The rail insert adjustment allows you to optimize the position of the resident coin to the falling coin. In order to get the best "comparison" of coins they need to "eclipse" each other when they are in the center of the sensor coil. The rail insert adjustment allows this exact match to occur. Performing this adjustment optimizes against fraud coins. The adjustment also allows compensation for worn parts to bring a highly used Comparitor back to optimum operating parameters.
- 2) Using the allen screw driver, turn screw slowly clockwise (see FIG. 4 & 5), observe the waveform, it should lower in amplitude, keep adjusting clockwise until smallest amplitude can be achieved. If using the Comparitor Test Station the lowest μA reading on the μA meter is desirable (refer to document #00300001 Comparitor Test Station User Manual). Remove sticks or taped coin after adjustment.

Selectivity adjustment:

- 1) Insert sample coin into "Sample Holder". Turn *Selectivity Adjustment Potentiometer* (see FIG.1 & 2) fully counter-clockwise (full accept position). Drop coins, all coins will accept. Turn potentiometer fully clockwise (full reject position). Drop coins, all coins will reject. To set for best performance for coin in residence which is the (sample coin), turn pot back, counter-clockwise in short increments, dropping coins frequently between turns, until coins begin to accept. Drop a good range of coins or tokens to make sure all coins accept, fine tune as necessary to accept all good coins or tokens and reject fraud coins.

AIR BALANCE PROCEDURES FOR THE INTELLIGENT COMPARATOR PRODUCT LINE

Preliminary setup:

- 1) Connect scope test probe to J4 PIN2 (see pg. 18 or 19) = pin 7 op-amp output. Refer to individual Mech Control PCB documentation (Schematic Diagram) J4 location. Ground the scope ground connection to J4 PIN 6. If using the Comparator Test Station connect a test lead from the *Mech Test Point* on the test station to the J4 PIN 2 on the PCB (refer to document #00300001 Comparator Test Station User Manual).
- 2) Set the Scope VOLT/DIV. to 500 mv. per division.
Set the Scope TIME/DIV to 1 ms. per division. Depending on type of scope, some waveform positioning may be necessary to view the whole waveform.

Air Null Balance setup :**For optimizing performance:**

- 1) Using the 1/16" allen head screw driver, back out the *Coil Adjustment Screws* (see FIG. 6 & FIG. 7) counter-clockwise approximately two full turns. Check the *Coil Mounting Screws* (see FIG. 6) holding the sensor coils together at approximately 3-1/2 in. lbs. of torque. Verify the torque on the two screws that hold the sensing coil stack together then seat the allen screws as indicated in step 2.

For new or rebuilt sensor coil assemblies:

- 2) Using the 1/16" allen head screw driver, turn the *Coil Adjustment Screws* clockwise (see FIG. 6 & FIG. 7) until screws **just** touch against the center coil metal pin stop. Make sure both screws are seated with equal depth into the sensor coil body.

Air Null Balance adjustment :

- 1) Start with connecting power to J1 connector (Refer to individual Mech Control PCB documentation. (Schematic Diagram) location and (Voltage Spec Sheet) for power input for the IC and other intelligent Comparitor models and switch on power. If the green led on the PCB doesn't light, turn power off and call Coin Mechanisms Inc.
- 2) Connect oscilloscope to J4 PIN 2 (see pg. 18 or 19). On the oscilloscope, you should see a large distorted waveform. If using the Comparitor Test Station connect a test lead from the *Mech Test Point* on the test station to the J4 PIN 2 on the PCB (refer to document #00300001 Comparitor Test Station User Manual). If the unit is out of calibration the needle on the μA meter will move up.
- 3) Using the allen wrench adjustment tool, insert tool into allen screw location on the number (1) (front) coil assembly (see FIG 6).
- 4) Turn allen screw with the wrench clockwise slowly until the waveform **just** starts to change or if you are using the Comparitor Test Station the needle on the μA meter moves slightly (refer to document #00300001 Comparitor Test Station User Manual).
- 5) While adjusting the number (1) coil adjusting screw in step 4. the waveform should increase in amplitude **slightly**. This adjustment should just allow the token holder "web" to easily slip into the "V" groove gap between the coils.

NOTE: DO NOT OVER ADJUST THIS SCREW AND CREATE AN EXCESSIVE GAP.

- 6) Insert the allen wrench through the clearance hole in the spring retainer assy (see FIG. 7) and into the allen screw location on the number 3 (back) coil assembly. Turn the screw with the allen wrench clockwise until the waveform amplitude on the scope is at it's smallest or lowest on the μA meter of the Comparitor Test Station.
- 7) Adjust the *Spring Retainer Adjustment Screw* clockwise until the screw **just** touches the main plate. This is to relieve strain on the #3 coil (see FIG. 7).
- 8) Verify the waveform or the μA meter reading returns to the settings achieved in the previous steps when the coils are squeezed together and released. Adjust coil adjustment screw on number 3 (back) coil assembly if necessary.

Note: Once the allen screw on the (1) coil bottoms (the waveform begins to get smaller), it should not take more than a quarter turn before the smallest amplitude has been reached. If more than a quarter turn is required to balance, contact Coin Mechanism Inc.

FIG. 1 AND FIG. 2

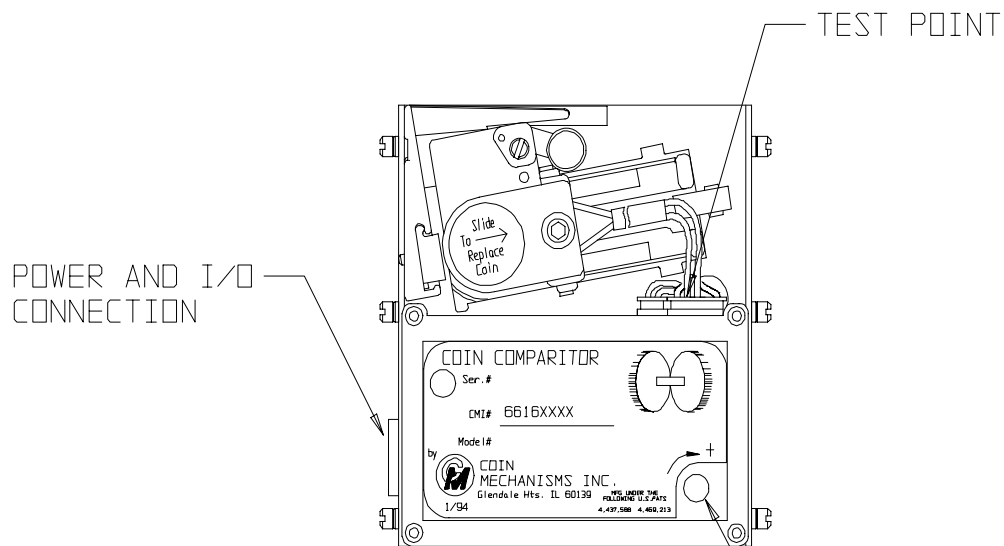

FIG. 1

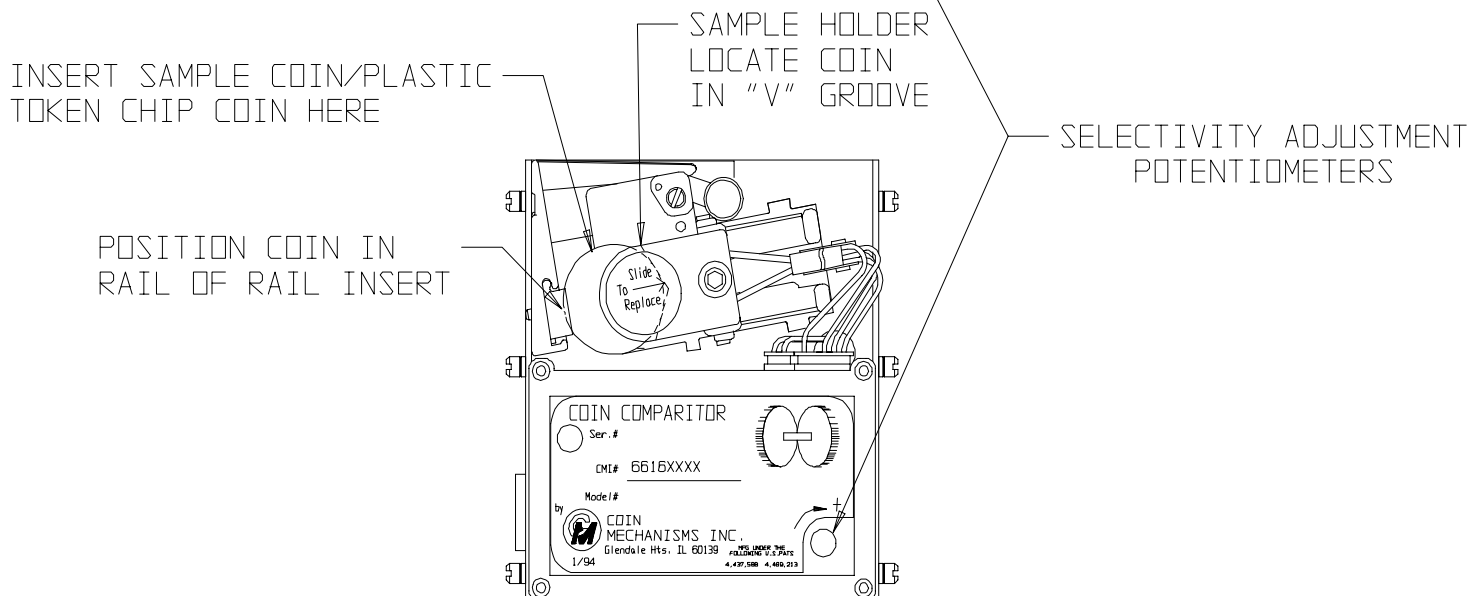

FIG. 2

FIG. 3, FIG. 4 AND FIG. 5

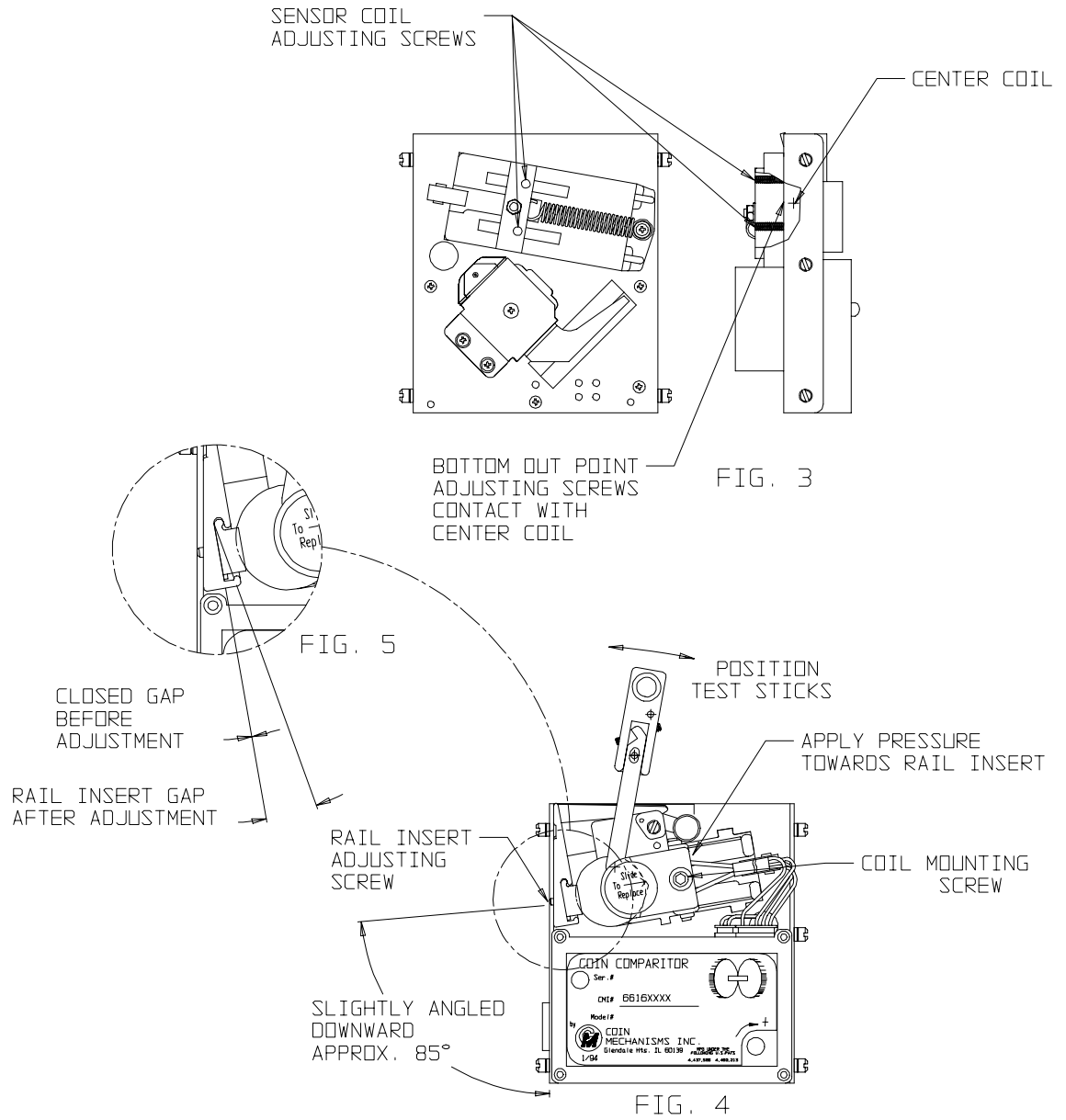

FIG. 6 AND FIG. 7

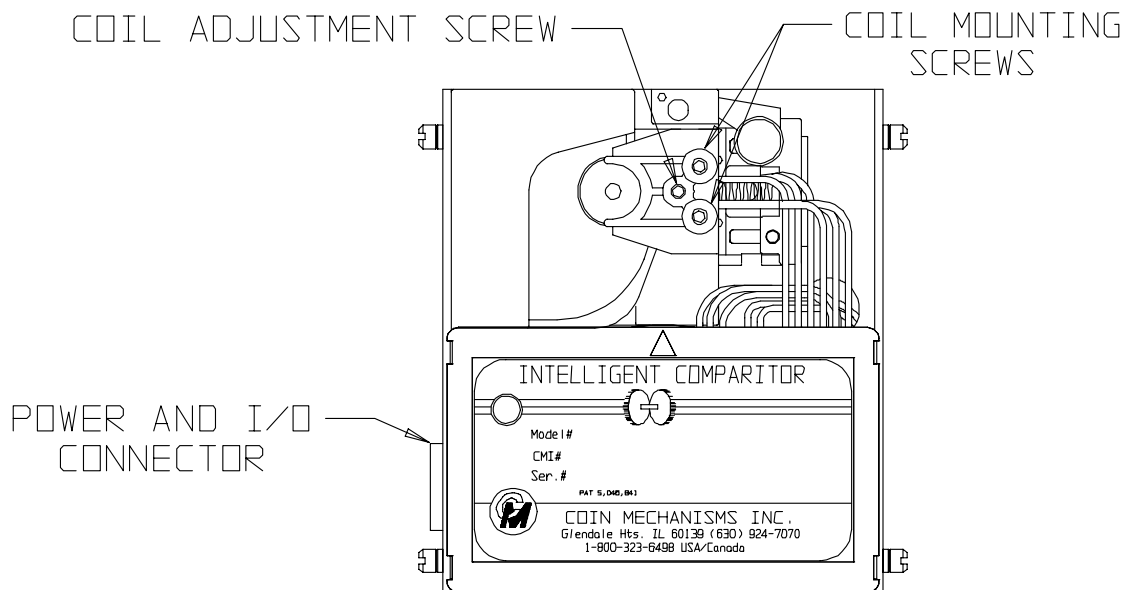

FIG. 6

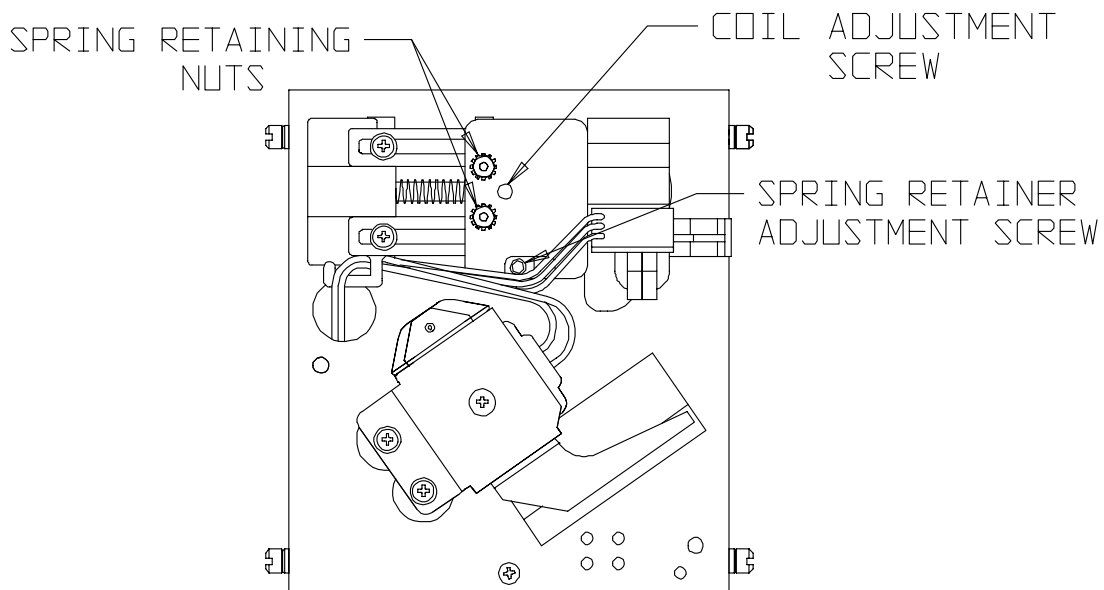
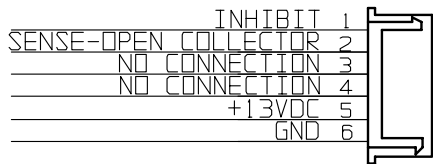

FIG. 7

FIG. 8

FIG. 8
IC-32, IC-36



Interface "A"

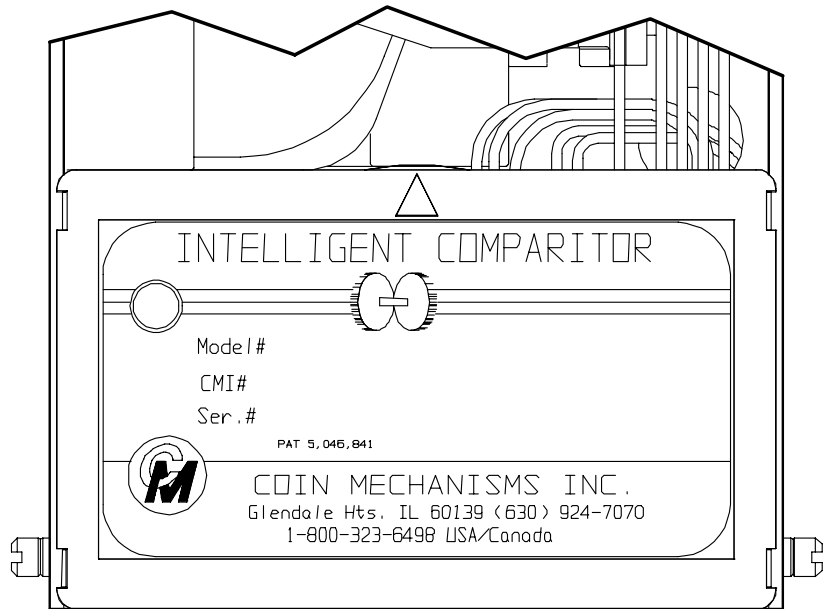

Test Stand
P/N 05000009

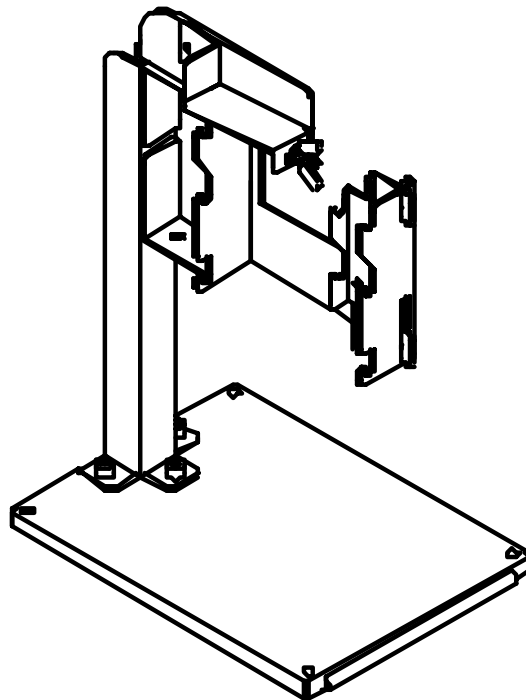

COIN COMPARITOR PIN NUMBER IDENTIFICATION

FIG. 9 AND FIG. 10

FIG. 9
CC-33 , CC-37

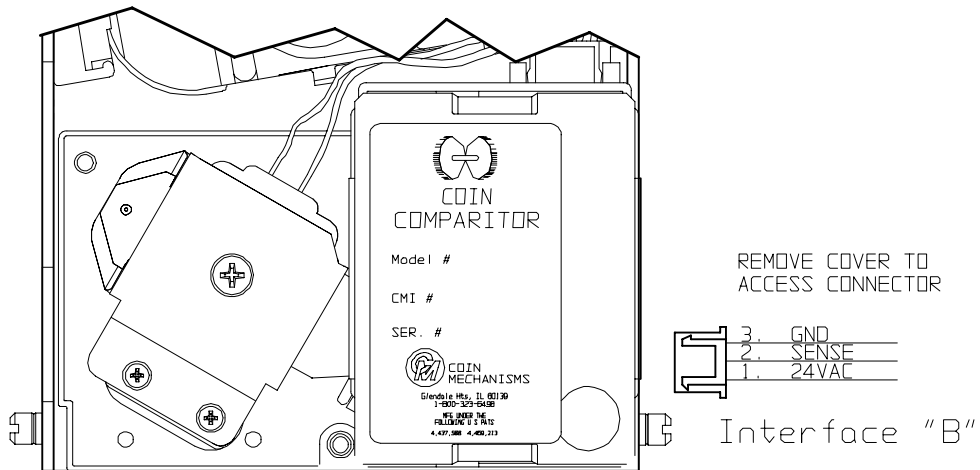
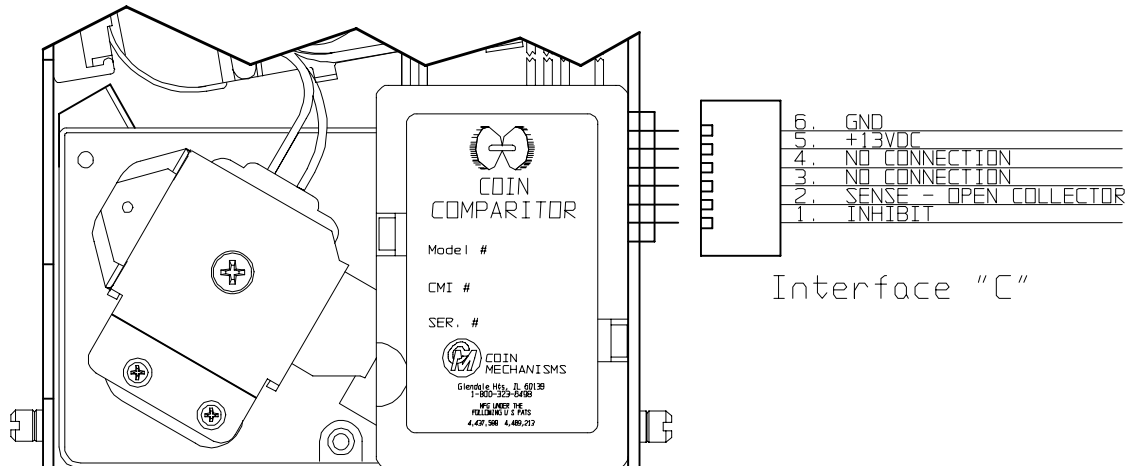

FIG. 10
CC-32 , CC-36



COIN COMPARITOR PIN NUMBER INDENTIFICATION

FIG. 11 AND FIG. 12

FIG. 11
IC-33, IC-37

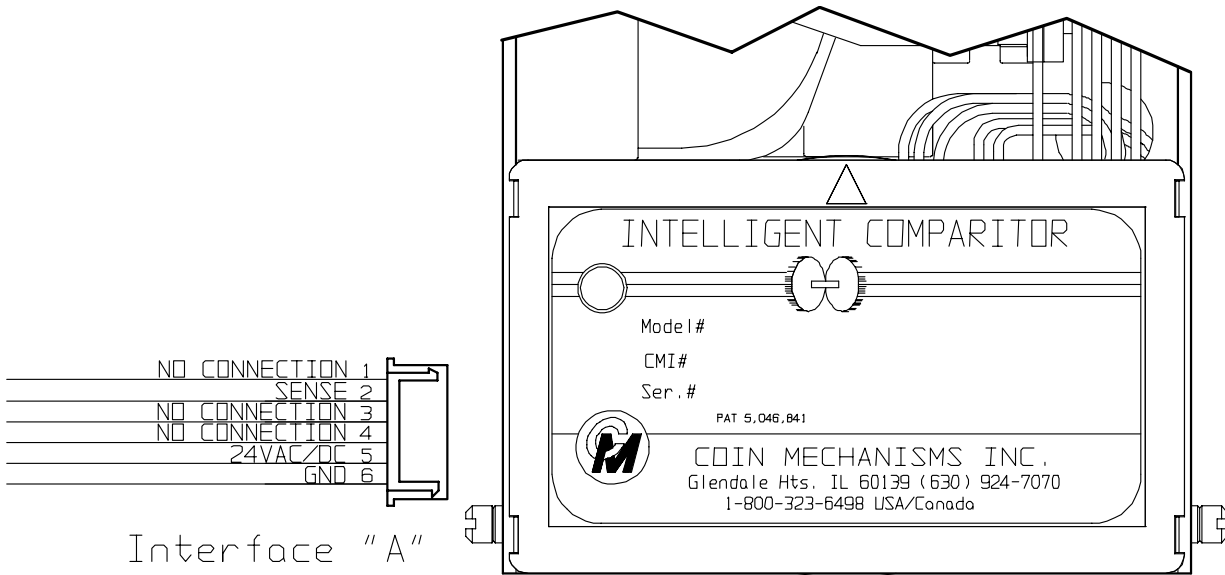
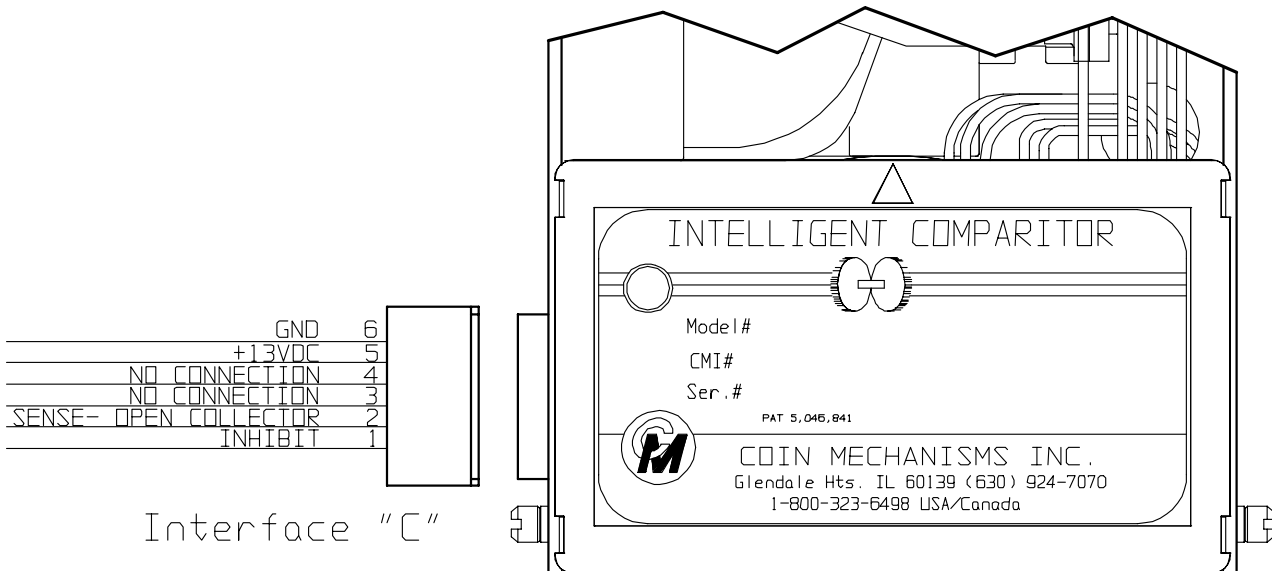
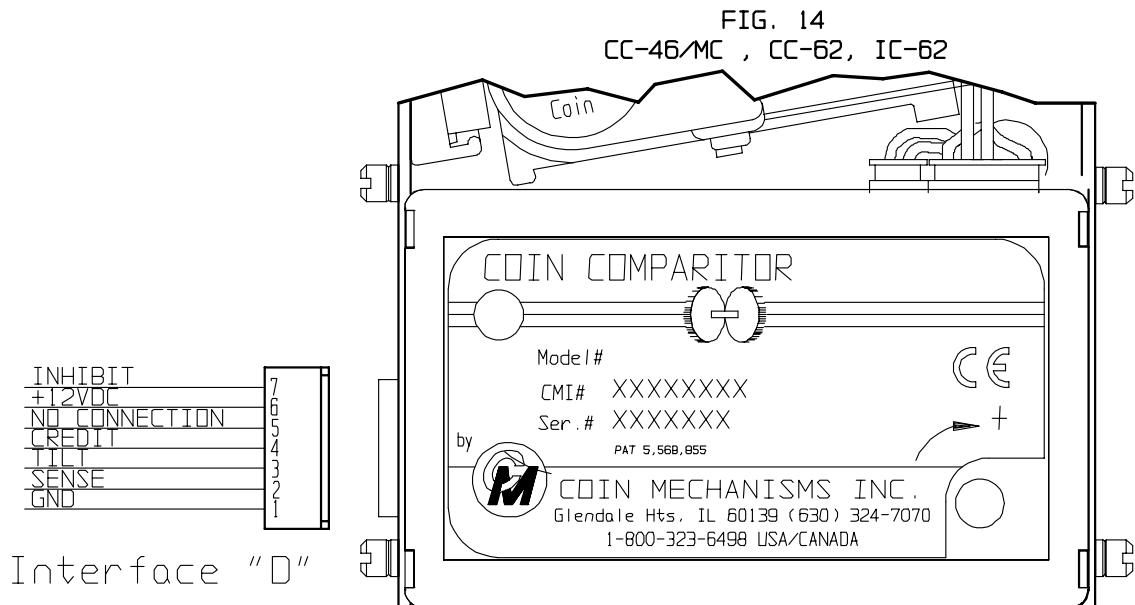
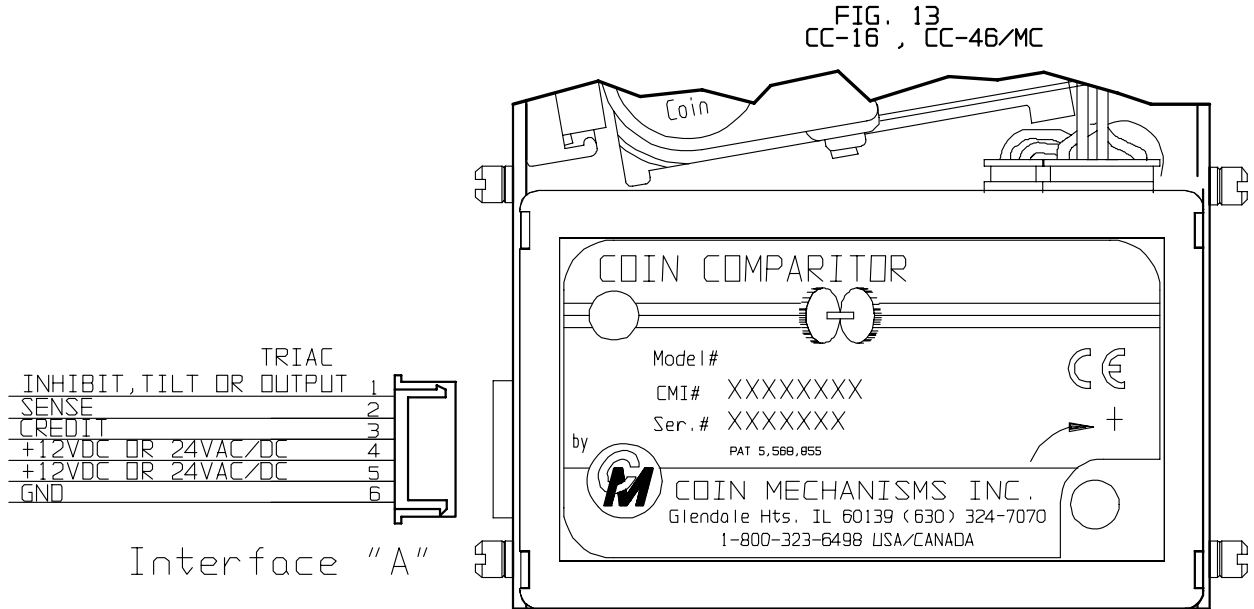

FIG. 12
CC-16, IC-16
13VDC INH



COIN COMPARITOR PIN NUMBER IDENTIFICATION

FIG. 13 AND FIG. 14



COIN COMPARITOR TEST POINT IDENTIFICATION

FIG. 15 AND FIG. 16

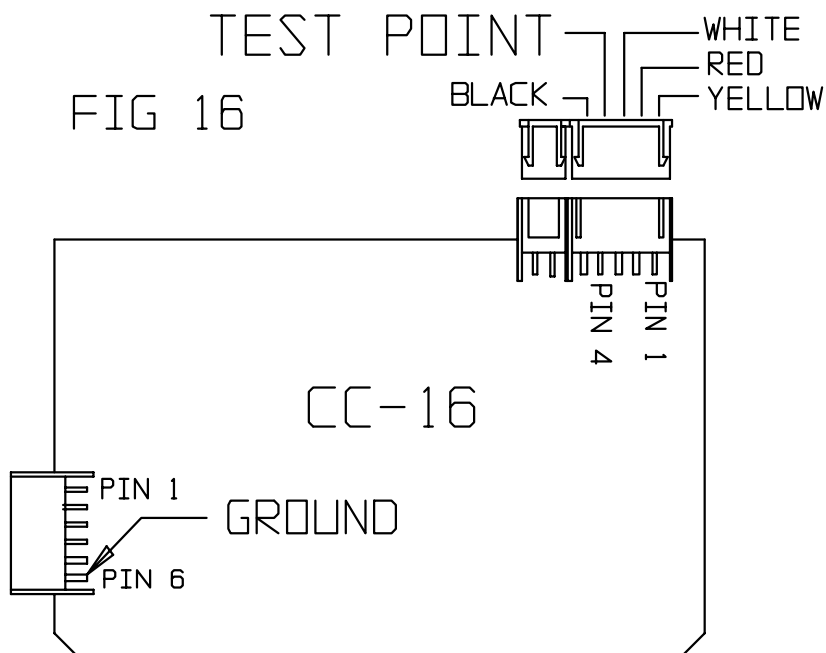
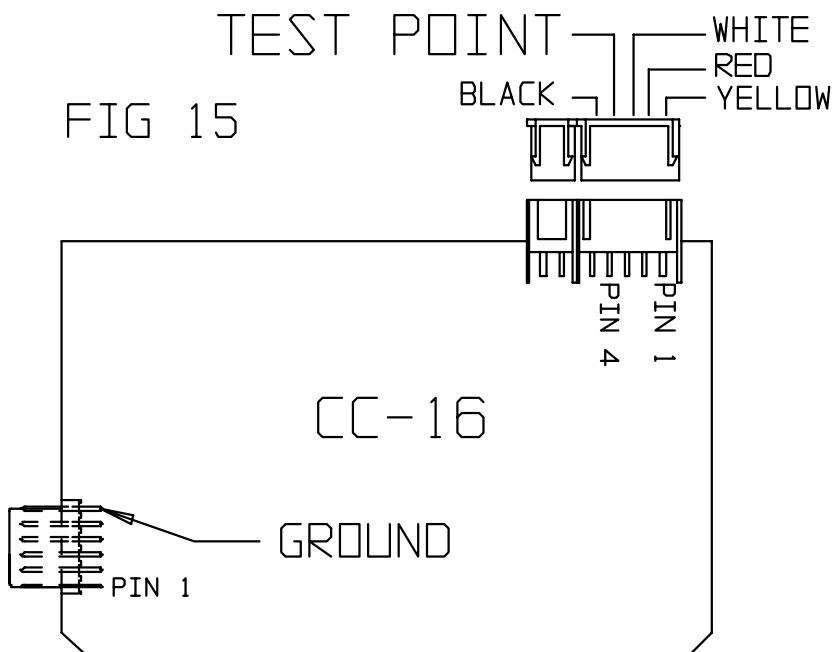

COIN COMPARITOR TEST POINT IDENTIFICATION

FIG. 17 AND FIG. 18

FIG 17

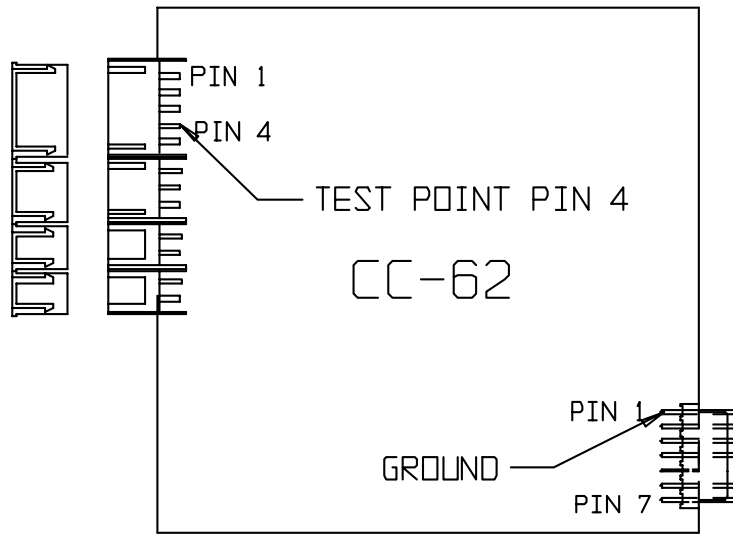
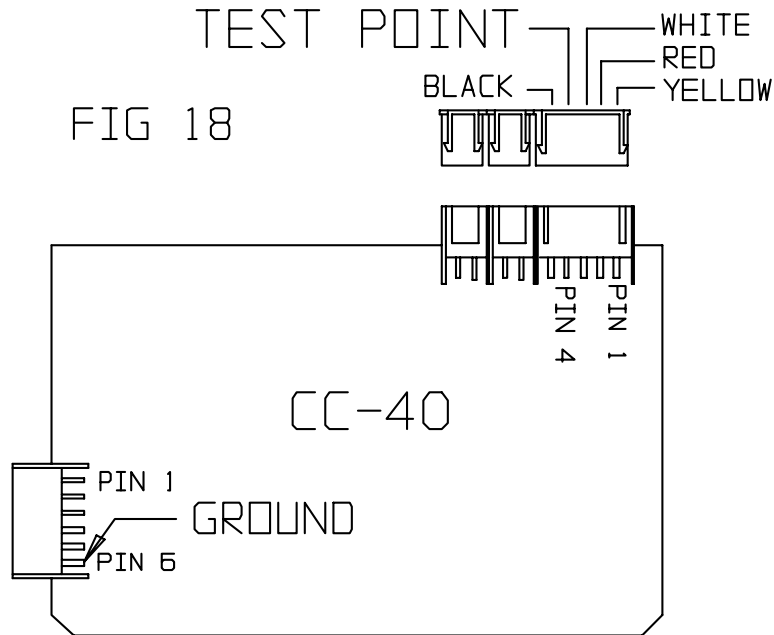

FIG 18



COIN COMPARITOR TEST POINT IDENTIFICATION

FIG. 19 AND FIG. 20

FIG 19

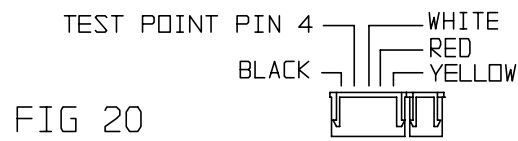
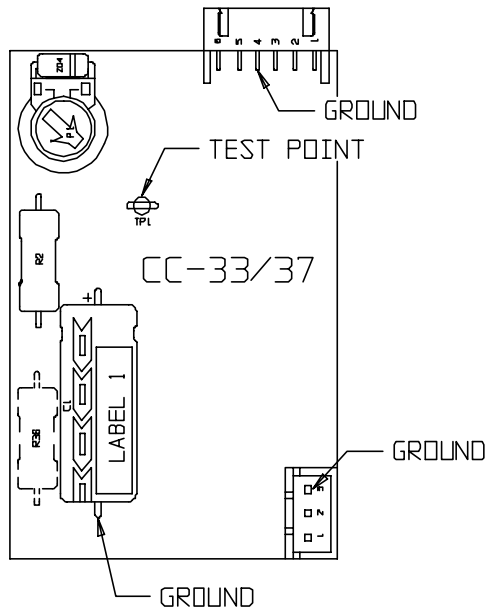
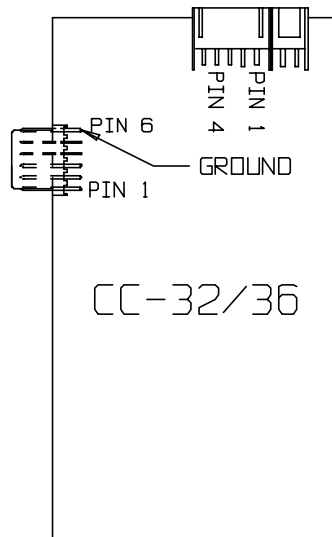
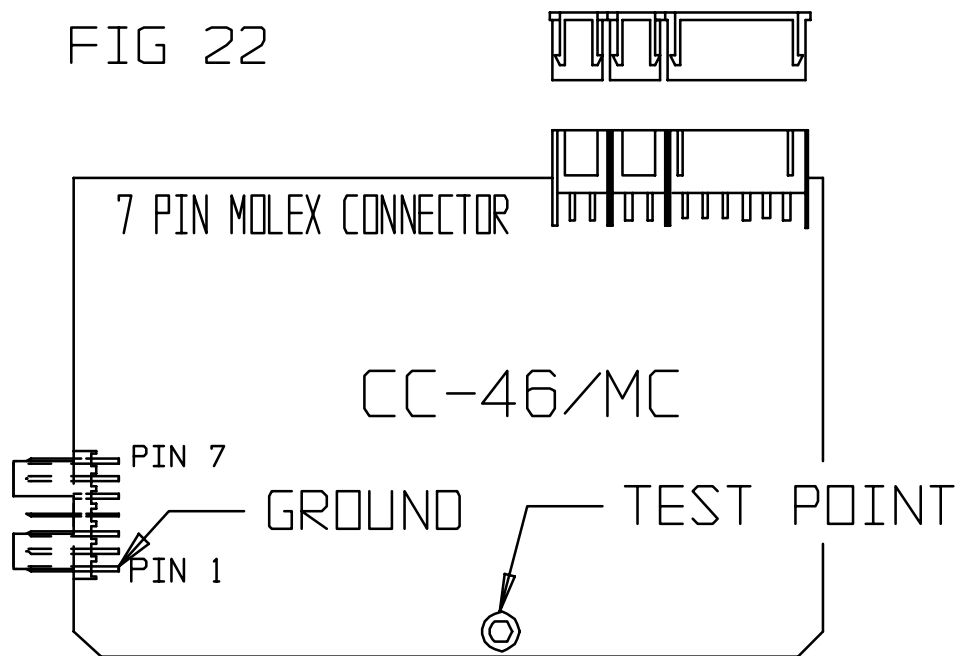
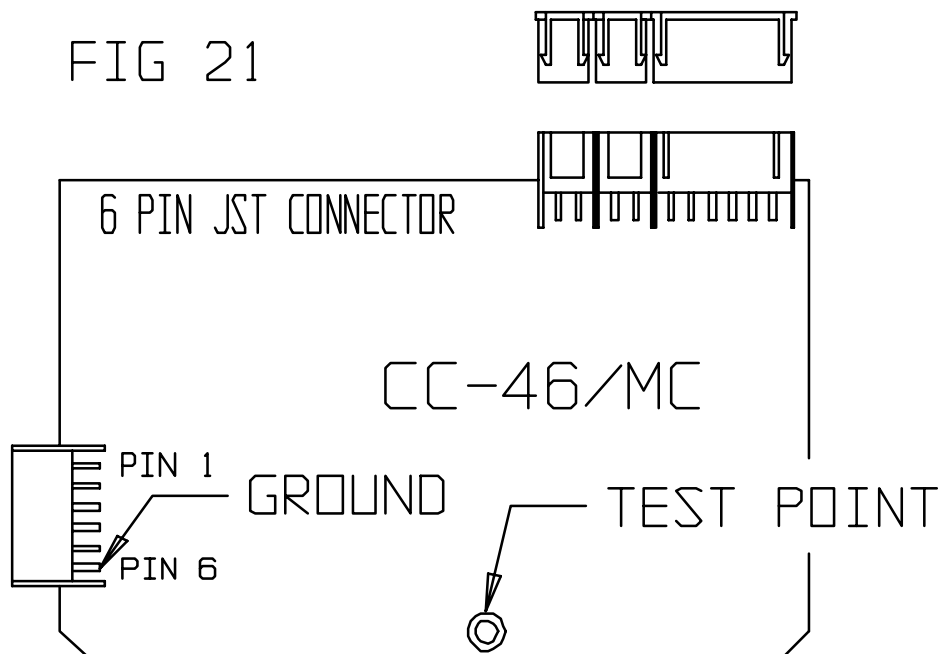

FIG 20



MICRO COMPARITOR TEST POINT IDENTIFICATION

FIG. 21 AND FIG. 22



INTELLIGENT COMPARITOR TEST POINT IDENTIFICATION

FIG. 23 AND FIG. 24

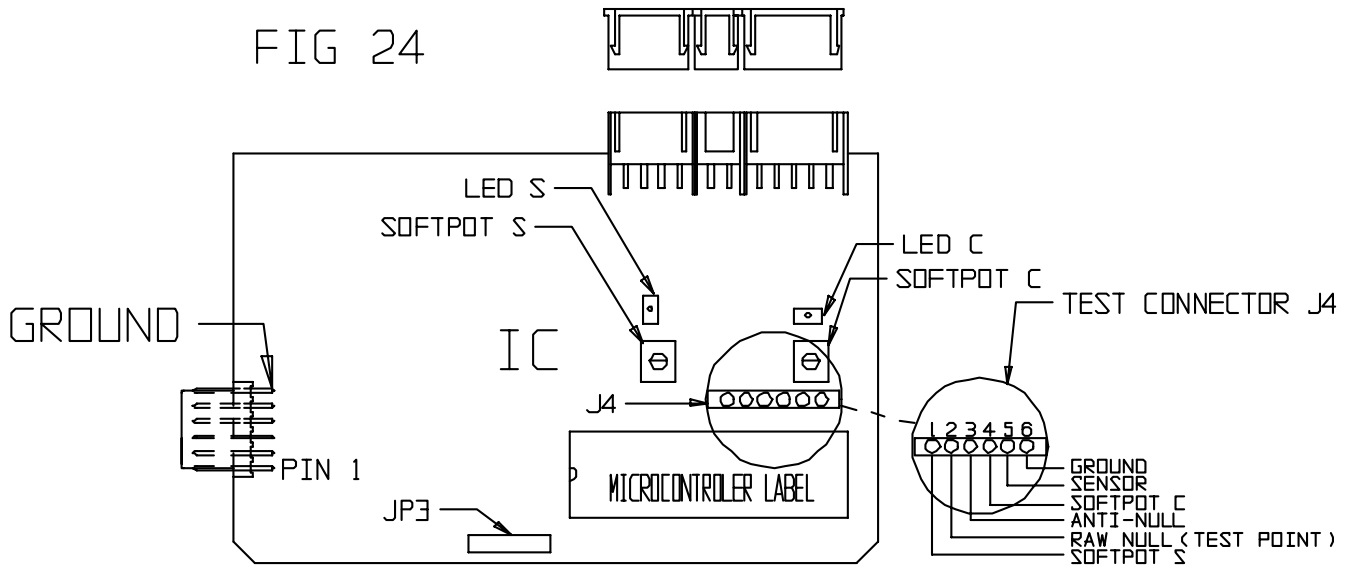
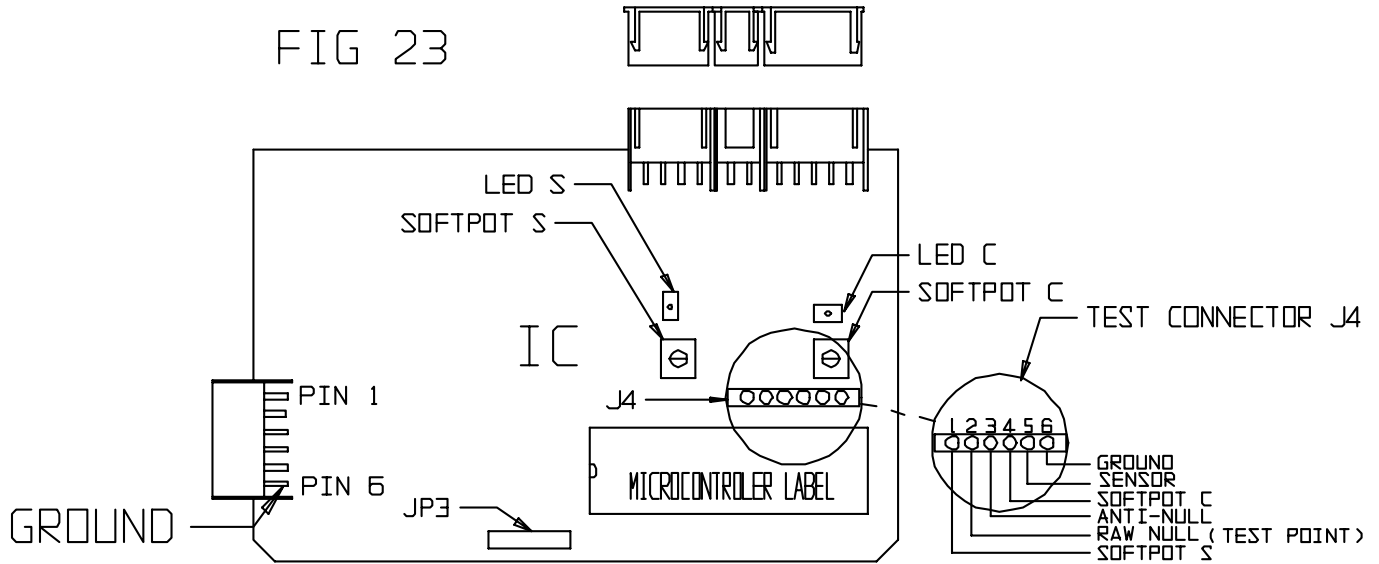

INTELLIGENT COMPARITOR TEST POINT IDENTIFICATION

FIG. 25 AND FIG. 26

