

# User's Manual

# DIGITAL THUNDER WALL

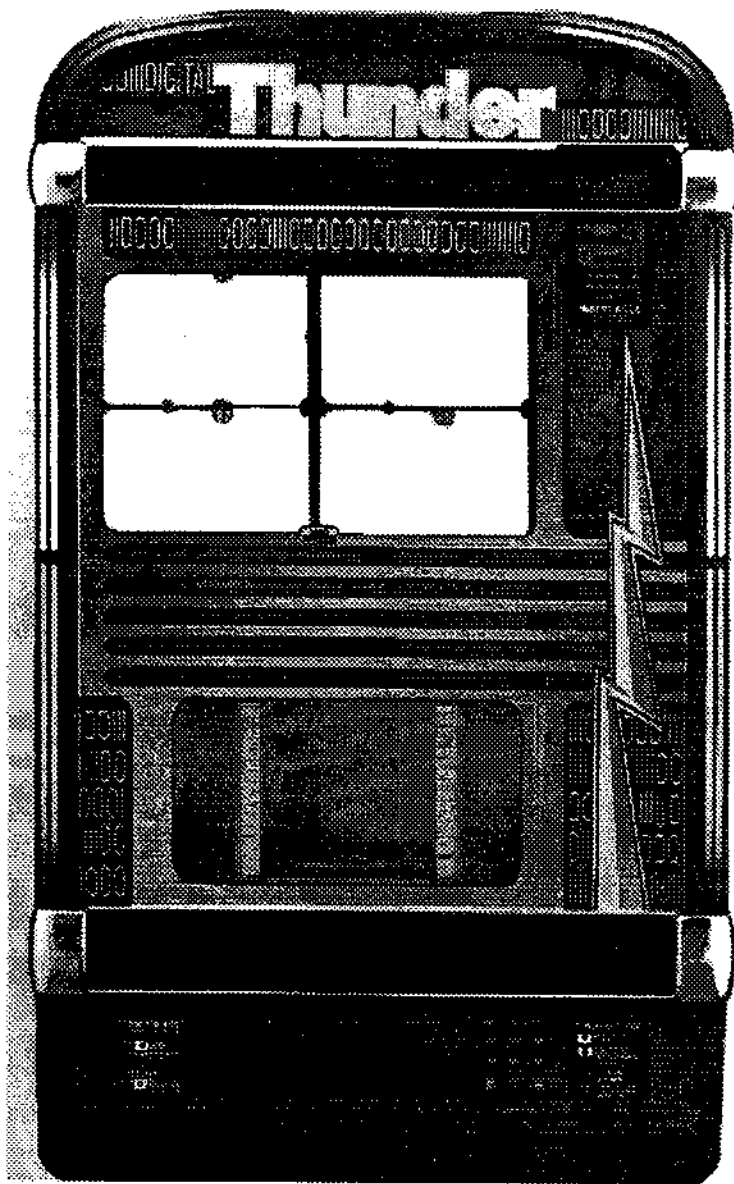

**Attention:**

**Before opening any parts or covers marked with this lightning sign or working at the components connected to the mains voltage, as power switch, mains transformer, fluorescent lamps and lamps holder, you must unplug the power cable!**



The CD-player with a laser scanning system used in this phonograph is a class I product (no risk, harmless laser system). The respective label is attached to the front of the changer behind the view-glass.

**CLASS 1  
LASER PRODUCT**

according to IEC 825

The information and illustrations contained in these technical documents are up to date at the time of publication.

Version 19/04/95 – 1

**Subject to technical modification without obligation to modify equipment already delivered!**

Copyright by

NSM Aktiengesellschaft \* 55411 Bingen am Rhein \* Germany

**No reprint in full or part unless approved!**

Manufactured in Germany

Part number of this documentation: 178 033



**KONFORMITÄTSERKLÄRUNG**

Wir  
NSM Aktiengesellschaft  
Saarlandstr. 240  
55411 BINGEN am RHEIN 1

erklären in alleiniger Verantwortung, daß das Produkt

**NSM-Musikautomat  
DIGITAL THUNDER**

auf das sich diese Erklärung bezieht, mit der/den folgenden Norm(en) oder normativen Dokument(en) übereinstimmt.

**EN 55 022; EN 60 555-2; EN 60 555-3**

Gemäß den Bestimmungen der Richtlinie

**89/336/EWG,**

Bingen am Rhein

21.02.95 Dr. Thomas Kühl

**DECLARATION OF CONFORMITY**

We  
NSM Aktiengesellschaft  
Saarlandstr. 240  
55411 BINGEN am RHEIN 1

declare under our sole responsibility that the product

**NSM-Phonograph  
DIGITAL THUNDER**

to which this declaration relates is in conformity with the following standard(s) or other normative document(s).

**EN 55 022; EN 60 555-2; EN 60 555-3**

following the provisions of directive

**89/336/EWG,**

Bingen am Rhein

02-21-95 Dr. Thomas Kühl

**DÉCLARATION DE CONFORMITÉ**

Nous  
NSM Aktiengesellschaft  
Saarlandstr. 240  
55411 BINGEN am RHEIN 1

déclarons sous notre seule responsabilité que le produit

**Juke Box-NSM  
DIGITAL THUNDER**

qui est l'objet de la présente déclaration est conforme à la (aux) norme(s) ou autre (s) document(s) normatif(s) suivants.

**EN 55 022; EN 60 555-2; EN 60 555-3**

conformément aux dispositions de la directive

**89/336/C.E.E.**

Bingen am Rhein

21.02.95 Dr. Thomas Kühl

**Note:** This equipment has been tested and found to comply with the limits for a Class B digital device, pursuant to Part 15 of the FCC Rules. These limits are designed to provide reasonable protection against harmful interference in a residential installation. This equipment generates, uses, and can radiate radio frequency energy and, if not installed and used in accordance with the instructions, may cause harmful interference to radio communications. However, there is no guarantee that interference will not occur in a particular installation. If this equipment does cause harmful interference to radio or television reception, which can be determined by turning the equipment off and on, the user is encouraged to try to correct the interference by one or more of the following measures:

- Reorient or relocate the receiving antenna
- Increase the separation between the equipment and receiver
- Connect the equipment into an outlet on a circuit different that to which the receiver is connected from
- Consult the dealer or an experienced radio/TV technician for help

**CAUTION:** Servicing is allowed for qualified service personnel only. To avoid electric shock do not perform any servicing other than that contained in this user's manual section 6 unless you are qualified to do so. Refer all other servicing to qualified service personnel.

**Directions for placement of the phonograph license certificate  
(USA market only)**

You will receive the license certificate after having paid the necessary fee to the Jukebox License Office.

Please find the registration documents within the phonograph.

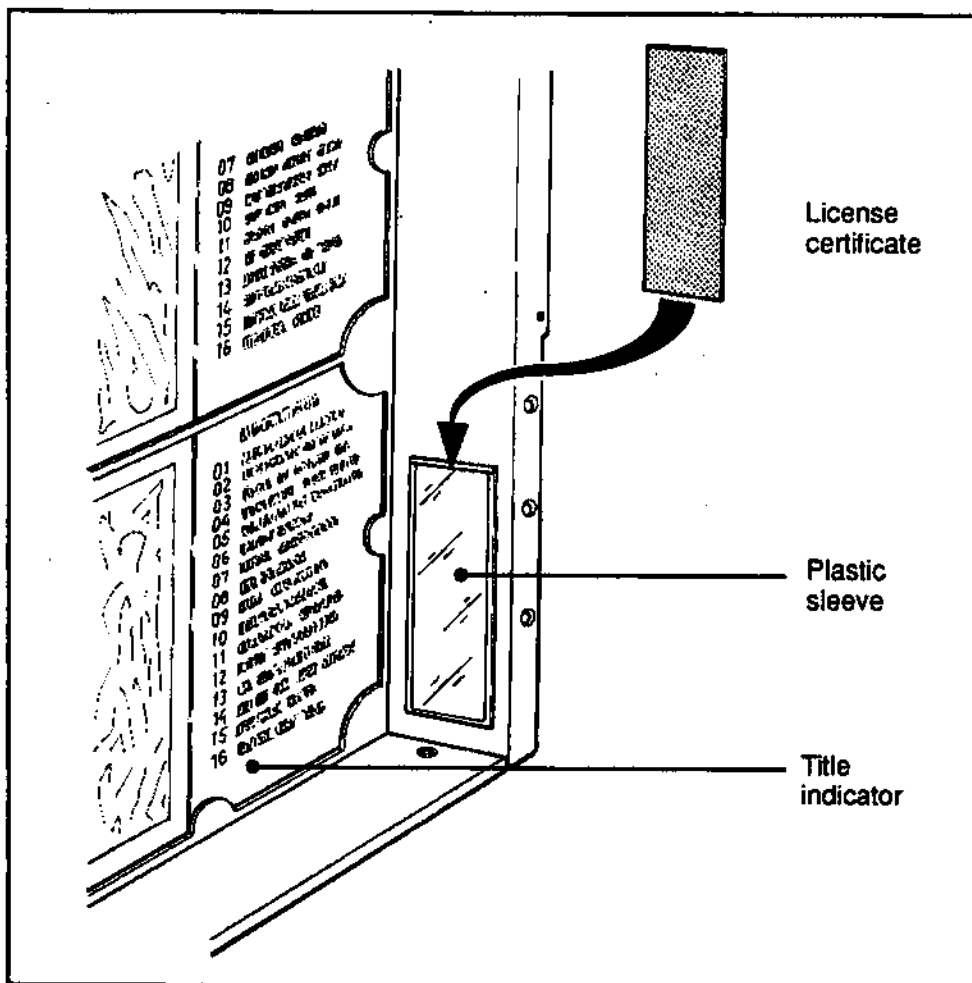

## **Preface**

### **Part I User's manual**

#### **About this manual**

In this user's manual of the NSM phonograph we have described how to install the phonograph easily and how to handle it so that it will work for a long time.

The phonograph is equipped with a **factory setting** of parameters concerning pricing and handling of CDs to allow you to get started easily.

If you wish to program individual settings of the phonograph you just have to follow the steps described within section 5 **Programming of special and individual settings**.

This user's manual is divided into 6 sections:

Table of contents is arranged in a manner that you will find any required information easily and fast.

#### **Section 1 System description**

Within this section a description of the phonograph is given, starting with unpacking the phonograph, followed by a component check list and the set-up procedure of the phonograph.

#### **Section 2 Functional description**

In this section we will introduce you to the main components of the phonograph as well as to the optional devices.

We will provide an overview of the possibilities offered by the audio system of the phonograph. Further attention is given to the principal of function of the CD changer and the title indicator.

#### **Section 3 Installation of the phonograph**

In this section we will help you to set up the phonograph. Due to the factory settings you will be able to play titles after inserting CDs and performing the CD recognition routines. The phonograph is ready to work using the factory settings.

#### **Section 4 Basic operation**

This step-by-step description is useful if you don't want to use the integrated phonograph programming routines.

We will explain the basic programming of price and monetary setting as well as how to read out the statistics of the last operation period. We will give you a short introduction to the remote control panel and the statistic evaluation. Furthermore, we introduce you to the possibilities of connecting more loudspeakers.

#### **Section 5 Programming of special and individual settings**

This section of the user's manual is reserved for the operator who wants to program individual settings of the phonograph such as Happy-Hour-play or Background music.

#### **Section 6 Maintenance**

Here you will find information about cleaning the surfaces and the housing or the CD drive.

### **Part II Service manual**

**You will get more information** concerning necessary repairs and the spare parts list herein. The Service Manual for the NSM phonograph has the part-no. 178 159.

Table of contents

page

<b>Section 1 System description</b> .....	<b>1-1</b>
The NSM phonograph Digital Thunder Wall .....	1-1
Introduction .....	1-2
Unpacking .....	1-2
Transportation security devices .....	1-5
<b>Section 2 Functional description</b> .....	<b>2-1</b>
Components of the NSM phonograph .....	2-1
The coin and bill chutes, playing instructions .....	2-1
The operating instruction .....	2-1
Display and keyboard .....	2-3
Options and accessories .....	2-8
Technical data of the phonograph .....	2-9
<b>Section 3 Installation of the phonograph</b> .....	<b>3-1</b>
Mains connection .....	3-1
How to load the CD storage magazines .....	3-2
Loading the title display .....	3-3
Initialize the loaded CDs to the control unit memory .....	3-6
Ready to play using factory settings .....	3-7
<b>Section 4 Basic Operation</b> .....	<b>4-1</b>
Changing the price – and monetary value settings .....	4-1
Example of programming the price settings .....	4-1
Summary of programmable features .....	4-5
Play Mode .....	4-5
Credits .....	4-6
Title display .....	4-6
Background Music .....	4-6
Advertising .....	4-6
Lock-out titles .....	4-6
Happy-Hour credits .....	4-6
Service and maintenance .....	4-6
Adjustments with Remote control .....	4-7
Volume controls .....	4-7
Muting .....	4-8
Free credits .....	4-8
Background music .....	4-8
Changing CDs and evaluation of the statistics .....	4-9
How to change CDs .....	4-9
How to evaluate the statistics .....	4-9

Table of contents

page

Data transfer and storage .....	4-10
Print-out in text mode .....	4-10
Print-out in graphic mode .....	4-10
<b>Connecting loudspeakers .....</b>	<b>4-13</b>
Stereo mode .....	4-13
Connecting loudspeakers of higher impedance .....	4-13
Mono mode .....	4-14
Sound system for separate rooms .....	4-14
Adjustments for better sound quality .....	4-15
Location of the mode switch .....	4-16
Connecting loudspeakers via output transformer .....	4-17
Extension Loudspeaker Operation .....	4-17
Definition of extension loudspeakers and calculation of their power consumption .....	4-18
Power calculation for the internal loudspeakers .....	4-20
Connection diagram for output transformer .....	4-21
Special connection / left channel inverted .....	4-23
Power values for special mode with inverted left channel .....	4-23
<b>Section 5 Programming of special and individual settings .....</b>	<b>5-1</b>
General information, command overview .....	5-1
The structure of the service program steps .....	5-4
1. Authorization (P001 to P003) .....	5-5
2. Statistics (P010 to P029) .....	5-6
Popularity .....	5-6
Hit Parade .....	5-7
Cashbox contents .....	5-7
Cash .....	5-7
Counter for number of coins / bills .....	5-7
Additional Counters .....	5-8
3. Data Transfer (P030 to P031) .....	5-9
Display of error numbers while evaluation is performed .....	5-9
4. Programming General Settings P040 to P054 .....	5-11
Light effects in stand-by .....	5-12
Light effects during play .....	5-12
Sound system settings .....	5-15
Maximum Volume Levels .....	5-15
Set volume for play mode .....	5-15
Sound setting .....	5-16
5. Price Settings P060 to P066 .....	5-17

Table of contents

page

Programming the price settings by standard values .....	5-18
Programming the price settings with custom settings .....	5-18
Programming an album bonus .....	5-18
6. Monetary Value Setting P070 to P077 .....	5-19
Bonus Credits .....	5-19
Indirect / direct money to credit revaluation .....	5-19
7. Programming Real Time Clock P080 to P082 .....	5-21
Set time .....	5-21
Set date .....	5-21
8. Programming Free Credits P090 to P094 .....	5-23
9. Programming Background Music P100 to P107 .....	5-25
10. Programming Auto Play P110 to P117 .....	5-27
11. Programming Advertisements P120 to P127 .....	5-29
12. Programming Lock-Out Titles P130 to P135 .....	5-31
13. Programming Happy-Hour-Credits P140 to P144 .....	5-33
<b>14. Initialization and Test Programs P150 to P164 .....</b>	<b>5-34</b>
Test Programs for Service Operation .....	5-34
Continuous run tests .....	5-34
Additional test programs for the service operator .....	5-36
15. Recording titles into title memory .....	5-37
15.1 Switching signal sources for testing the audio amplifier .....	5-38
<b>6. Section Maintenance .....</b>	<b>6-1</b>
Cleaning the housing of the phonograph .....	6-1
Cleaning the inside of the phonograph .....	6-2
Lubrication chart for the title display .....	6-2
.....	6-5



**List of figures**

Figure 1: NSM phonograph Digital Thunder Wall, general view of the several components ..	1-1
Figure 2: CD changer, transportation fixtures .....	1-5
Figure 4: The operating instruction of the phonograph .....	2-1
Figure 5: The title display .....	2-2
Figure 6: The rocker button for moving the title holders .....	2-2
Figure 7: Operating instruction of the phonograph .....	2-3
Figure 8: Structure of the Central Unit .....	2-5
Figure 9: Structure of the Control Unit .....	2-5
Figure 10: Structure of the main components of the audio system .....	2-6
Figure 11: CD changer .....	2-7
Figure 12: The Service switch .....	3-2
Figure 13: Placing CDs into trays .....	3-2
Figure 14: Loading of title holders .....	3-3
Figure 15: Sequence of title holders .....	3-4
Figure 16: The synchronisation marks of the title display .....	3-5
Figure 17: Display after entering the service mode .....	3-6
Figure 18: Wiring diagram and layout of the CB Adaptor .....	4-4
Figure 19: Remote control .....	4-7
Figure 20: Evaluation using the NSM DATAprint .....	4-10
Figure 21: Sample print-outs of the DATAprint 3000 .....	4-11
Figure 22: Stereo mode with normally connected loudspeakers .....	4-13
Figure 23: Stereo mode with connected loudspeakers of high impedance .....	4-13
Figure 24: Mono mode with connected loudspeakers for seperated rooms .....	4-14
Figure 25: Mono mode with serial connected loudspeakers in one room .....	4-14
Figure 26: Mode switch S1 placed on the CB CENTRALEINHEIT ES 5.1 .....	4-16
Figure 27: Connection diagram for loudspeakers and output transformer .....	4-21
Figure 28: Connection diagram for special mode with inverted left channel .....	4-24
Figure 29: Display after entering the service mode .....	5-1
Figure 30: Key pad layout for volume setting .....	5-15
Figure 31: Key pad layout for sound setting .....	5-16
Figure 32: Key pad layout for command "set time" .....	5-21
Figure 33: Key pad layout for command "set date" .....	5-22
Figure 34: Key pad layout for command "set day code" .....	5-22
Figure 35: Cleaning of the phonograph .....	6-1
Figure 36: Lubrication chart of the title display .....	6-2

**List of tables**

Table 1: Factory setting values of the phonograph .....	3-7
Table 2: Programming of price settings: .....	4-1
Table 3: Programming the monetary value settings .....	4-2
Table 4: Calculation of the loudspeaker's power .....	4-19
Table 5: Selecting power for internal loudspeakers .....	4-20
Table 6: Overview of Commands of the Service Program .....	5-4
Table 7: Price Settings .....	5-17
Table 8: Monetary Value Settings .....	5-20
Table 9: Error Displays .....	5-35

# Section 1

## DIGITAL THUNDER WALL

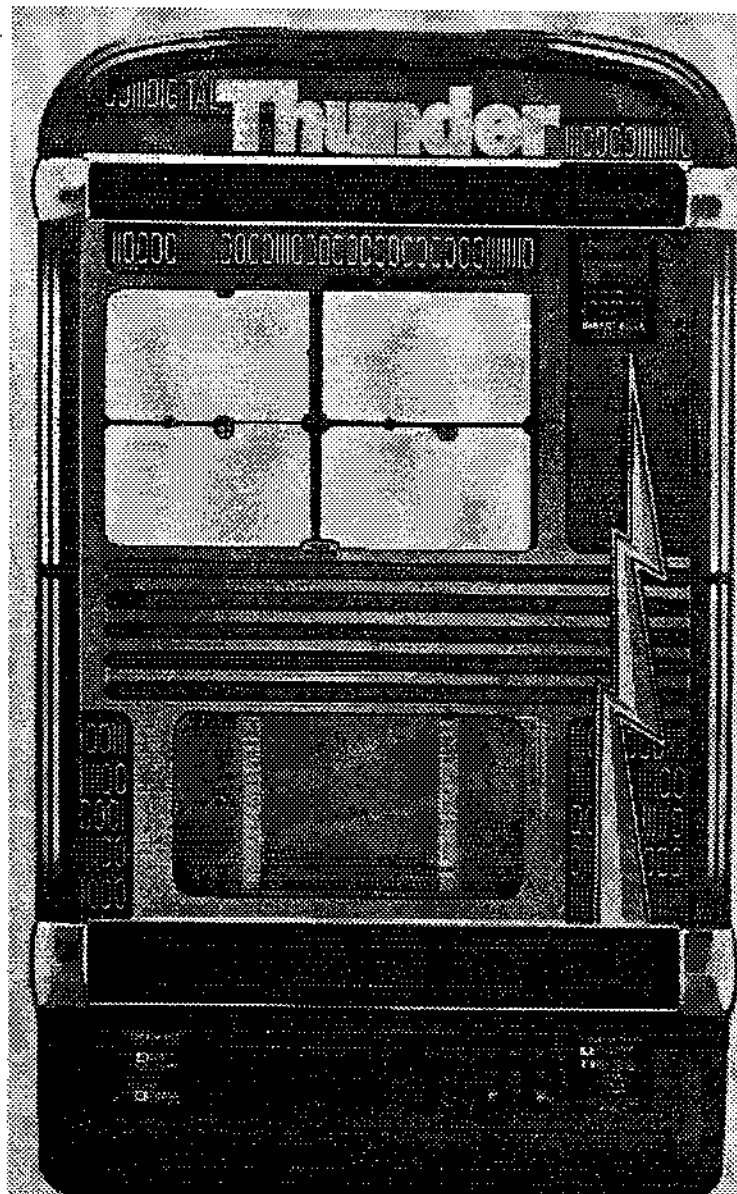

## System description

## Section 1 System description

### The NSM phonograph Digital Thunder Wall

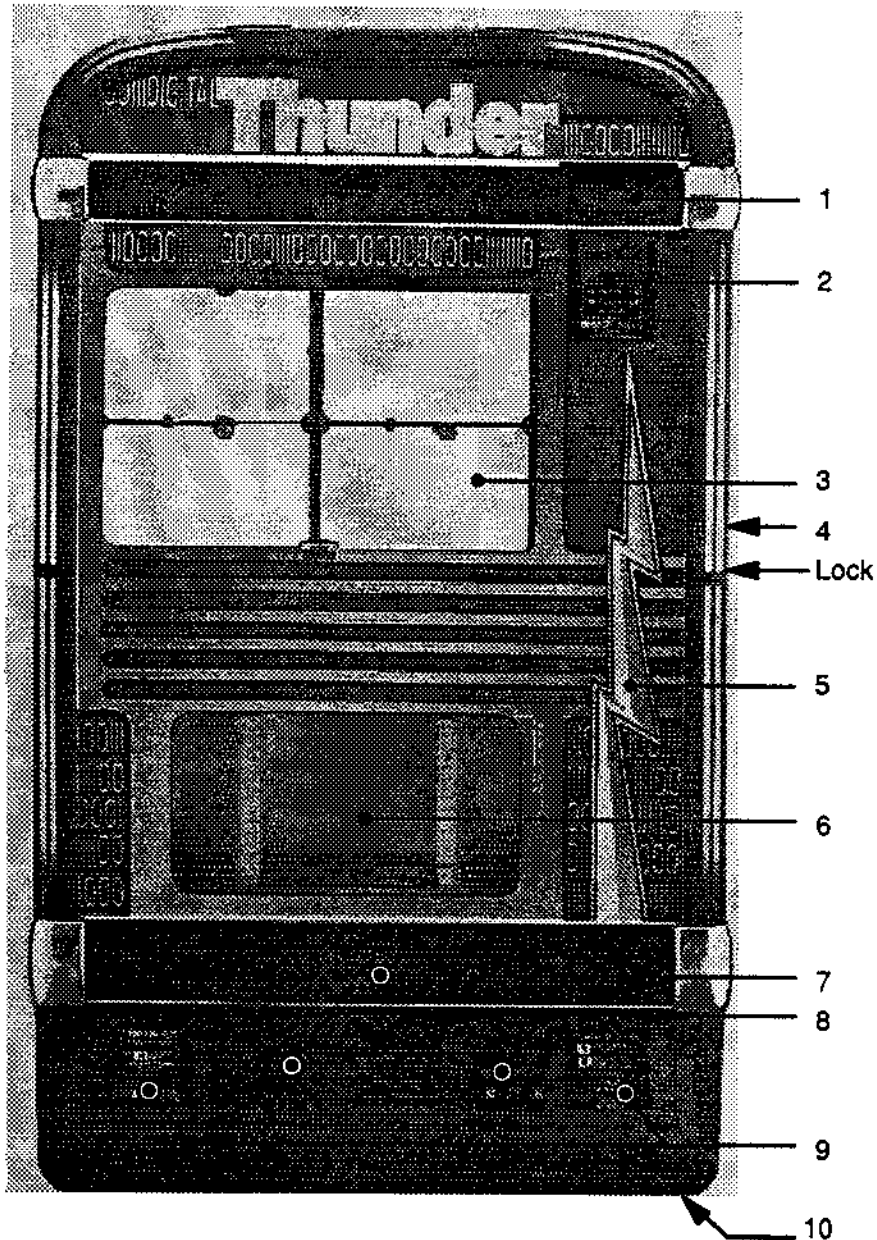

- |                          |                        |
|--------------------------|------------------------|
| 1 Money insert*          | 6 CD-changer           |
| 2 Operating instructions | 7 Rocker button        |
| 3 Title display          | 8 Display              |
| 4 Coin return cup        | 9 Playing instructions |
| 5 Light play             | 10 Keyboard            |

\* = OPTION

Figure 1: NSM phonograph Digital Thunder Wall, general view of the several components

## Introduction

Congratulations for having purchased this high quality phonograph. It is built with the famous 100 CD changer already known from our preceding phonographs. This phonograph performs a music power of 200 W per channel.

### Before you begin

Please read the first three sections of this manual and pay special attention in order to perform an error-free installation.

Remove all transportation security devices carefully from the phonograph in order to avoid destruction and malfunctioning of the phonograph.

**Be careful with the power supply.** Connect the phonograph only to the mains voltage indicated on the label on the power cord.

Level the phonograph carefully to avoid malfunctioning of the coin acceptor, the CD changer and the title indicator.

Check the operating conditions. Storage and operation of this phonograph are recommended in dry rooms only.

## Unpacking

### Transport damages

If the shipping carton shows damage due to transport, this should at once be recorded on the delivery slip of the shipping papers and then endorsed by the person making the delivery.

**The manufacturer is not liable for damages during transport!**

### List of delivered components

After opening the shipping carton you should find the following :

Phonograph

Cabinet key taped onto the frontglass

Inside the phonograph:

Additional keys in the cash box

User's manual

Quick reference manual at the rear of the title display

### Cabinet keys

After removing the shipping carton you will find one cabinet key taped onto the front glass. The other keys are placed in the cashbox inside the phonograph.

To open the cabinet put the key into the lock at the middle of the right side of the housing (see fig. 1) and turn to release the lock. The door opens to the left.

**Watch out** for the movement of the door in order to avoid injury.

Perform a visual control of all components to be placed right and to be well-connected. Refer also to figure 1.

## Use NSM Mounting Bracket (Part-No. 040 739)

In order to guarantee a correct functioning of the coin mechanism mount the phonograph horizontally and vertically exactly. Therefore, we recommend the practical NSM mounting bracket.

Take care to mount the bracket untwisted since the rear of the cabinet can otherwise be twisted.

To secure the phonograph to the bracket, a holding screw with sleeve –Part No. 176 999 (M 10x20)– of the accessory bag is to be used.

Plug in connection cable before mounting (also see section 3: "Mains Connection").

Secure mounting of the machine is very important since besides the danger of severely damaging the machine, the operator is responsible for all damages caused by an incorrectly mounted wallbox. When choosing the fastening material, take into account the machine's weight of 83 kg. We recommend dowel pins in sufficient quantities.

The screws should be at least 6 mm in diameter!

Example of mounting the NSM mounting bracket using nylon dowel-pins

First a few tips:

- The maximum bearing capacity of nylon dowel pins may only be achieved with the greatest possible screw diameters and with screws exceeding the dowel point by the screw diameter again.
- Please ensure that with fixings in hollow brick and hollow blocks the expansion zone of the dowel is completely anchored in at least one stone web.
- Determination of minimum screw length

1xd (d=nominal diameter of screw)  
 + dowel length  
 + thickness of plaster and/or insulating material  
 + thickness of mounting bracket 3 mm  
 = min. screw length

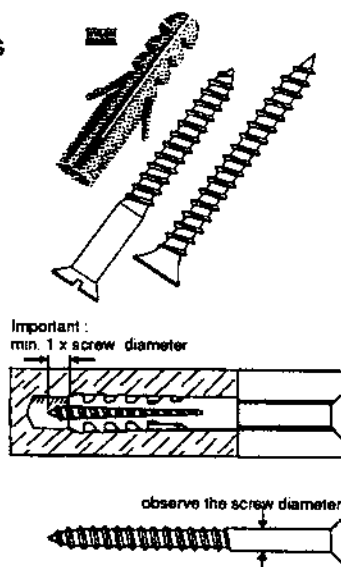

If you observe these tips you will have created the prerequisite for secure fixings.

Pull-out values in kN\*. Determined in each case with the largest screw diameter (steel screw) and with flush fixing of the dowel in the load-bearing anchorage base.

Allowance must be made for an appropriate safety factor.

Dowel:	<b>S8</b>
Wood screws Ø	<b>6 mm</b>
Concrete B25	<b>4,5 kN</b>
Aerated concrete GB 3,3	<b>1,2 kN</b>
Aerated concrete G 4	<b>1,3 kN</b>
Solid brick Mz20	<b>4,1 kN</b>
Perforated brick Hz20	<b>3,0 kN</b>

The following points must be observed when drilling, irrespective of the material:

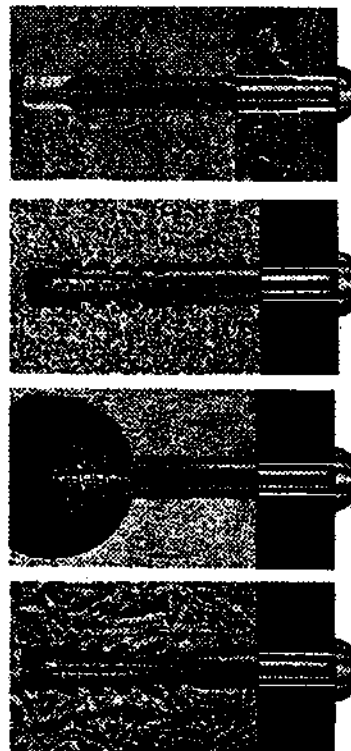

**Drill hole geometry**

The exact drill hole geometry dictates the load-bearing capacity of a dowel. Therefore always drill at right-angles and do not change direction during drilling. This has especially to be observed in the case of soft materials.

**Drill process**

The following drilling methods are possible depending on the type of drilling machine:

- Rotary – without impact
- Impact drill—many impacts with a low amount of impact energy. Fast rotation
- Hammer drill – few impacts with a high amount of impact energy. Slow rotation

The material determines the drill process:

- Solid materials of dense structure: impact and hammer drilling
- Hollow brick, materials of low strenght and aerated concrete, only rotary so that the hole does not become too big and in hollow brick the webs do not break out

Never forget to remove the dust from the drill hole after drilling. Only then the dowel performs safety fixing.

**Pull-out values, safety factors**

The pull-out values (breaking loads) given in this chapter are mean failure loads determined in at least 5 tests in uncracked building material. Failure criteria may be: failure of building material, breaking of bolt, loosening of anchor, breaking of anchor.

The maximum working load is calculated by dividing the pull-out value (breaking load) by the safety factor.

As a safety factor we recommed: for nylon dowel pins  $v \geq 7$ .

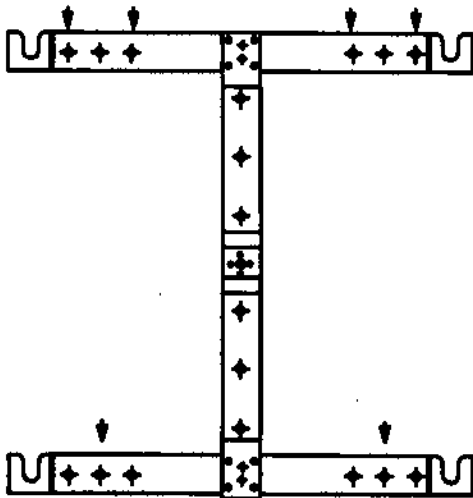

Example: In aerated concrete GB 3,3 the pull-out value for dowels type S8 and screws with a diameter of  $\varnothing = 6\text{mm}$  is 1,2 kN. Divided by safety factor 7 becomes

$$1,2 \text{ kN} / 7 \approx 0,17 \text{ kN} = 17 \text{ kp for 1 screw.}$$

The weight of the machine is nearly 83 kg; therefore at least

$$83 / 17 \approx 5 \text{ screws are necessary.}$$

For additional safety reasons and for better symmetry you should use 6 screws. Also see arrows in left hand figure.

When fixing the machine to the wall, make sure the vent is not hindered in its function. When using the mounting bracket, there is normally enough distance between cabinet and wall for air circulation. Push wall hangings decrease this distance; in that case the bracket has to be fastened to a flat board. Do not mount machine above heaters!

**Observe When Using an Upright Stand**

If the phonograph is mounted on a stand, it must be made sure that it cannot fall over. Therefore, it is recommended to use sandbags for example to weigh down the stand. The phonograph should not tip over with opened door and up to an angle of 15° out of the vertical line!

## Transportation security devices

Before operating the phonograph all security devices for safety and protection during transport have to be removed.

Note: Prior to any further transportation the security devices for safety and protection during transport have to be re-inserted.

Avoid static discharge to the phonograph. Electro Static Discharge (ESD) may destroy the optoelectronics and other ESD sensitive parts within the phonograph.

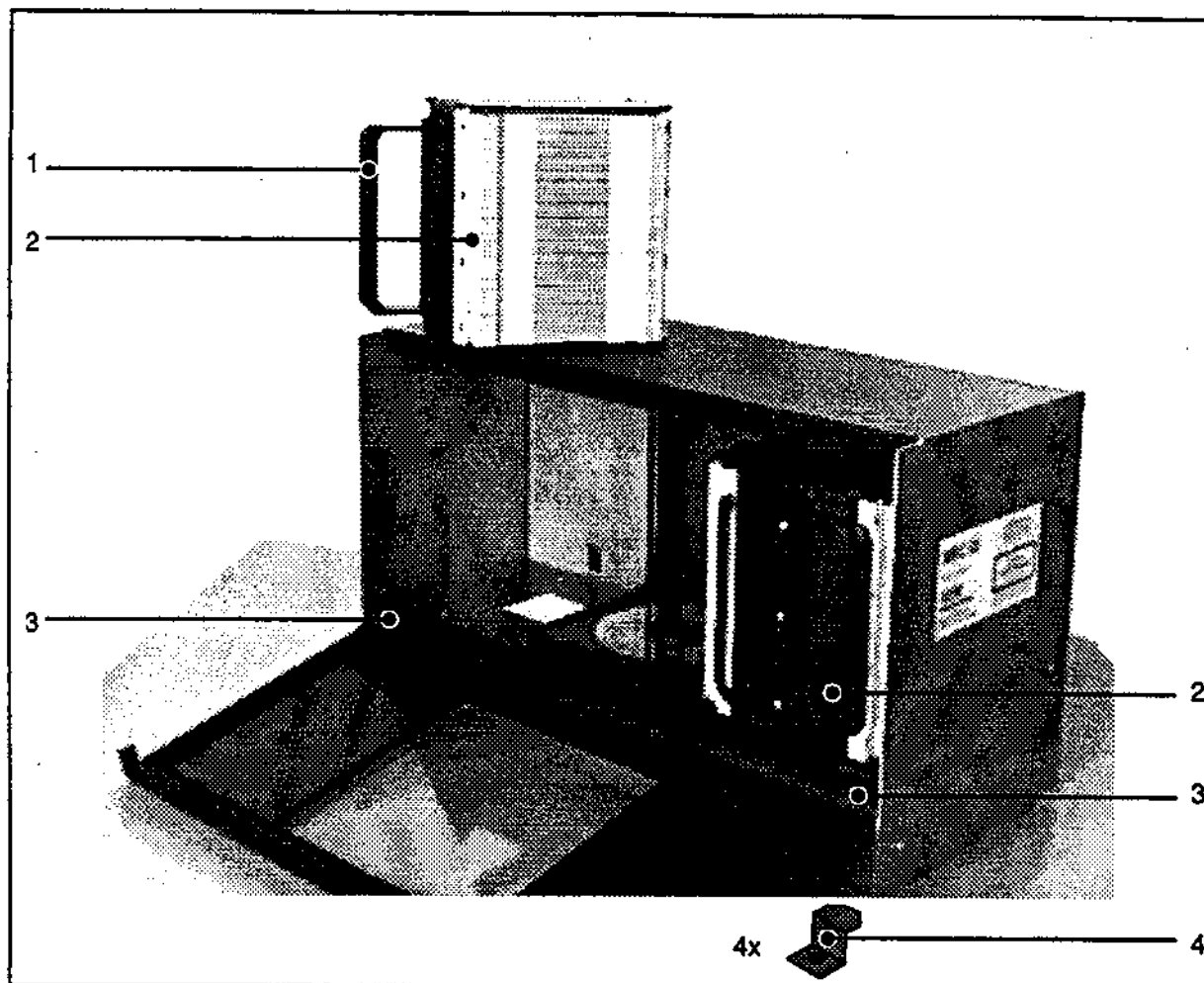

Figure 2: CD changer, transportation fixtures

### Removing the transportation fixtures

1. Open the phonograph.
2. Open the front door of the CD changer.
3. Remove the card board transportation fixture, located between the two CD storage magazines.
4. Swing the two handles (Fig. 2-1) ahead together if you wish to take out a magazine.
5. Push the corresponding black knobs to the outer side (Fig. 2-3).
6. The magazine (Fig. 2-2) audibly jumps out of the locking device and can easily be removed out of the changer.

**Note:** The four transportation fixtures (Fig. 2-4) on the edges of the CD-changer must only be removed in case of an acoustic feedback caused by vibration of loudspeakers mounted right besides the phonograph. Therefore loosen the screws and remove the fixtures.

Carefully keep the transportation fixtures for a future transportation; deposit them in a convenient location within the cabinet.



## Section 2

# DIGITAL THUNDER WALL

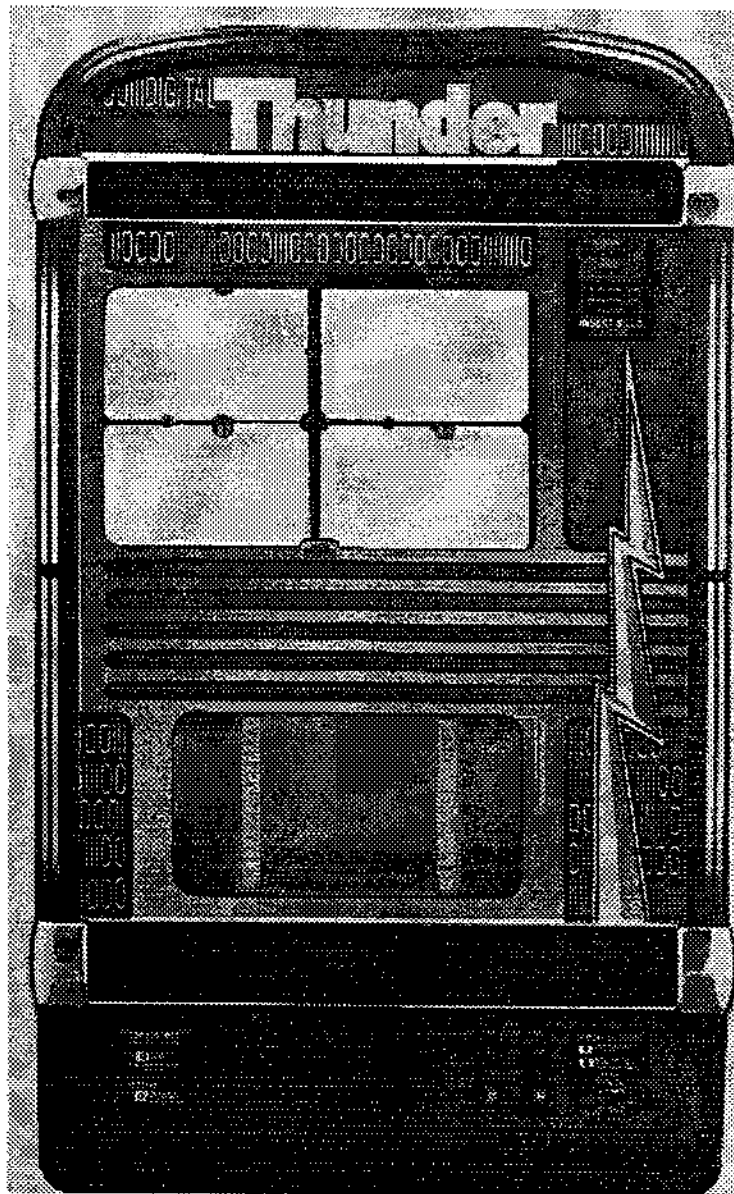

## Functional description

## Section 2 Functional description

### Components of the NSM phonograph

In the following chapter you will be introduced to the main components of the NSM phonograph "Digital Thunder Wall". Refer to figure 1 for locating the several components.

### The coin and bill chutes, playing instructions

To earn credits for playing different titles you have to insert either coins or bills.

Look at the stickers on the lid to perform right inserts of money.

You also have the possibility to change the number of credits for a title selection or an album selection. Then you have to replace the corresponding credit stickers by new ones.

Note: If you wish to change any credit setting don't forget to change the operating instructions.



Figure 3: The playing instruction for the phonograph (coin or bill insert)

### The operating instruction

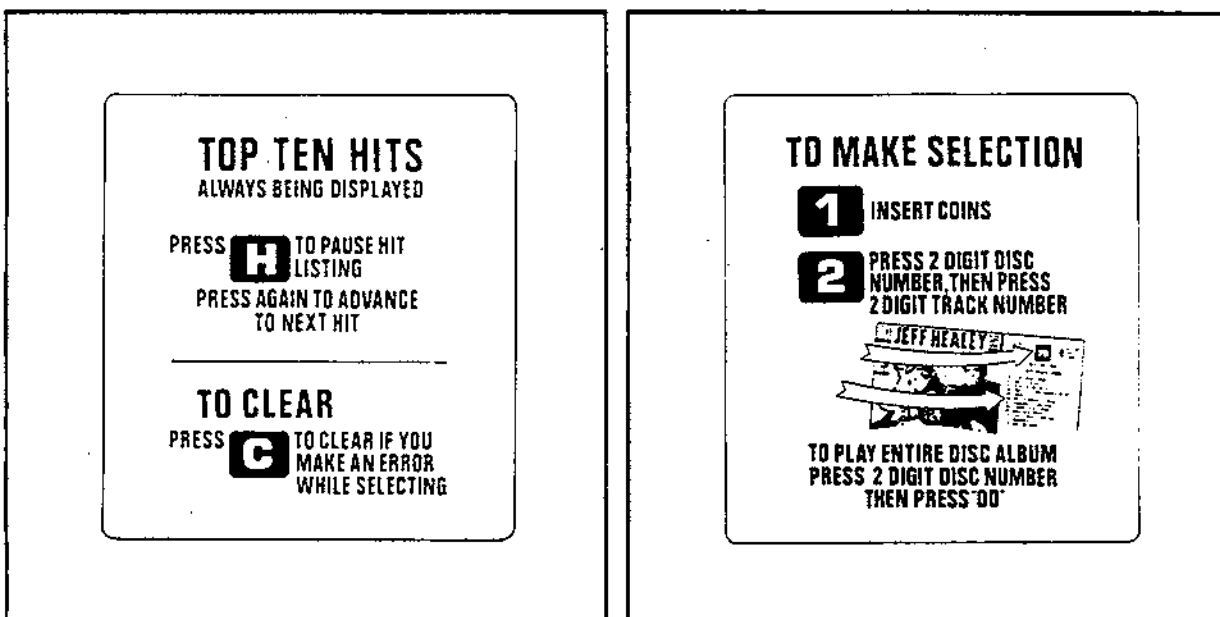

Figure 4: The operating instruction of the phonograph

### The title display

The title display is integrated into the phonograph. It is mounted to a hinge pin on the inner left hand side and is locked with a knob on the inner right hand side. Just lift the knob a little and swing out the title display to the left.

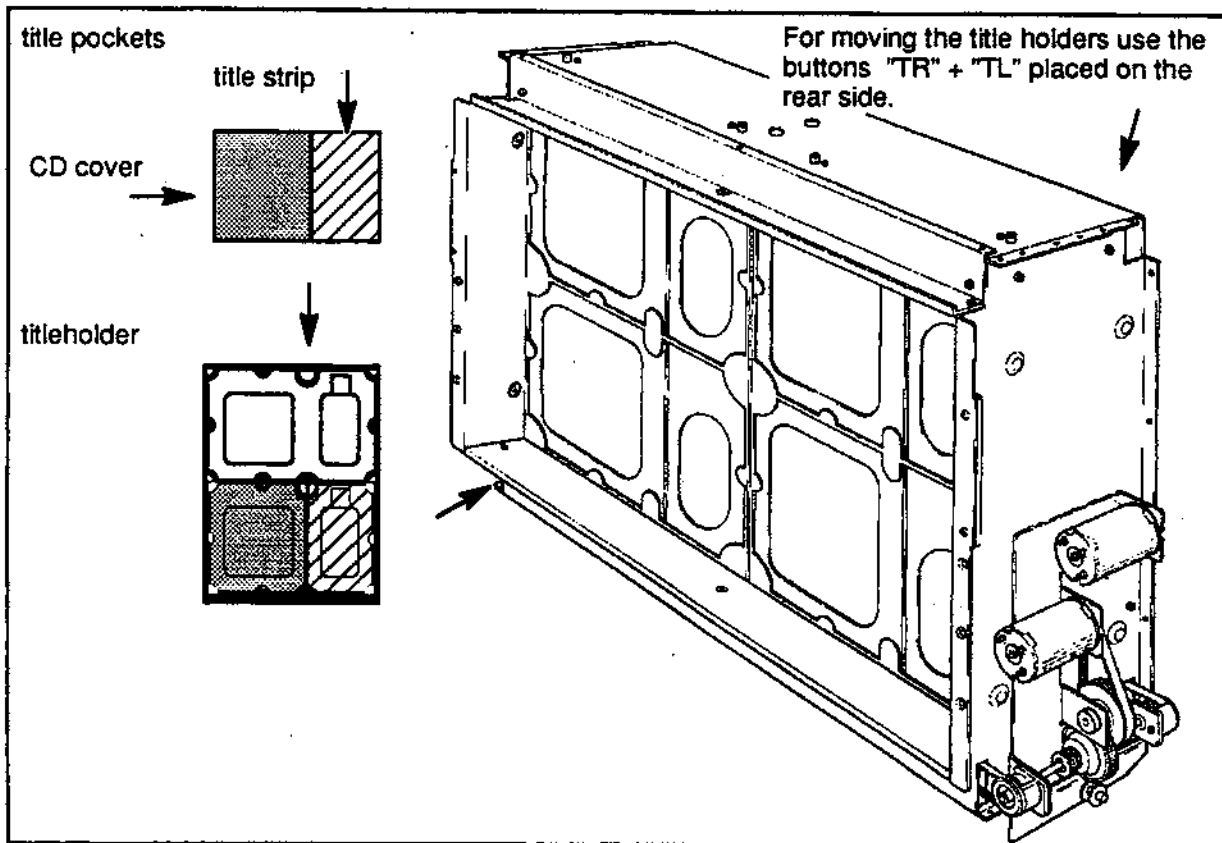

Figure 5: The title display

### The rocker button

When the door is closed, the title holders can be moved into the corresponding direction by pressing this button. Upon each button operation four new CD-covers including title strips are shown. In case of a limitation of selectable CDs by programming P042 (refer to chapter Programming of the phonograph) only the corresponding title holders are shown.

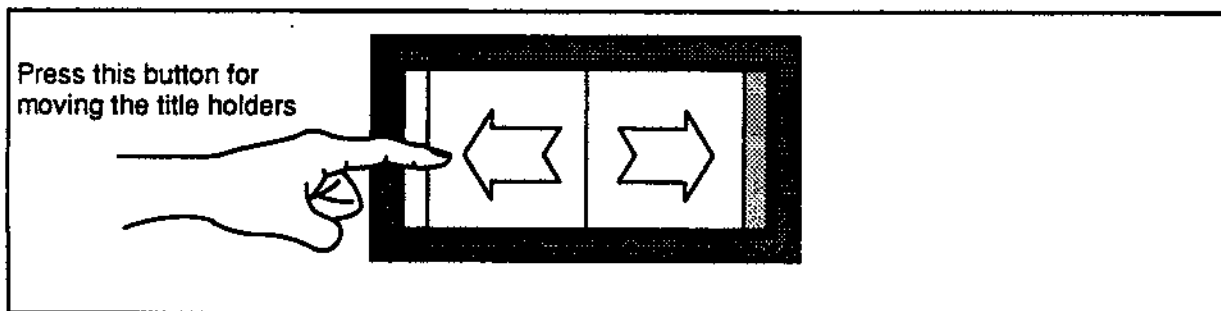

Figure 6: The rocker button for moving the title holders

**Display and keyboard**

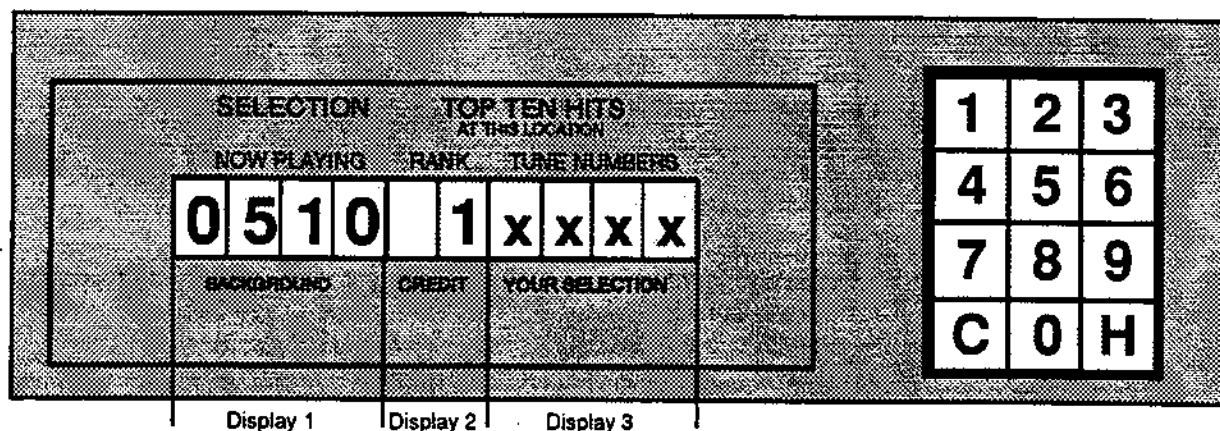

Figure 7: Operating instruction of the phonograph

The phonograph is equipped with a keyboard having digits "0" to "9" and "H" and "C". The multi-functional display consists of three parts. You will get different information via the display depending on the mode of operation of the phonograph:

**Immediately after power-on** the phonograph performs a self-test of the memory components of the control unit and all pre-programmed values. Afterwards display 1 shows the program version of the phonograph software for 2 sec.

If an error is found during the self-test, the error code is displayed as "Er xx" for 2 sec. With Er 31 (unverified memory contents) and Er 40 (price settings incorrect) display 1 shows the program step which needs to be re-programmed as Pxxx (refer to chapter **Programming of the phonograph**).

**Note:** For other Er-numbers on display 3, even during operation, refer to the Service manual of the phonograph to get more information about error locating or trouble shooting.

During stand-by the phonograph calculates the ten most played titles out of the last 30 titles played. On display 3 the title numbers of the 10 most popular titles are shown rankings (1-10) are shown on display 2. This "hit display" is changed in intervals of 2 sec. Also the lamp "10 top hits" lights up.

When pressing the key "H", the hit display can be stopped for 16 sec. Each pressing of the key "H" causes an advance to the next hit.

**Note:** When the popularity counters are erased (program step P033, refer to section 5 **Programming**), the hit parade is erased, too. In that case "0" appears for ranking until records are played again.

After insertion of a coin the hit display is interrupted, the lamp "10 TOP HITS" turns off, and the lamps "credits" and "your selection" light up. Display 2 shows the number of credits. For every selection credit is deducted. If not enough credits are available for the selection, the lamp "credit" flashes.

No more coins being inserted within 16 sec. or no selector key being pressed, the mode changes to "hit display".

After selection of a title the CD to be played is transported to the player and then played. Just before start the number of the title is shown on display 1 ("SELECTION NOW PLAYING"). After the disc has been played, the display is erased and the CD is transported back to its magazine space.

**Note:** If an error occurs with the CD changer or the player, "Er 7x" or "Er 6x" appears for 2 sec. In that case refer to the Service manual to get more information about error locating or trouble shooting.

During programming mode the display shows the selected programming step with actual values. Use the keyboard to change settings.

**Note:** Programming is possible only if the phonograph is in service mode. Refer to chapter **Programming of the phonograph**.

### Selection of CDs

If there is enough credit for at least one track/title to be played, this title can be selected by entering the corresponding number of the CD and the track. This four digit number consists of two parts:

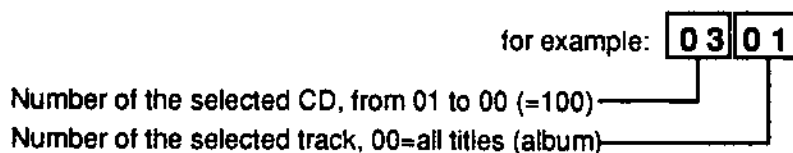

The lamps "credits" and "your selection" light up. The selection can be corrected by pressing "C" up to 2 sec. after pressing the 4th digit.

Album selection: When entering track 00, all titles of a CD are automatically played (i.e. 0300 = all titles of CD 03).

**Note:** Because there are only two digits reserved for the number of the CD, we have defined that the hundredth CD of our CD changer is designated with number 00.

**Central Unit**

The power supply, stereo amplifier with fan control, interfaces for the inputs of microphone, CD drive, tape and remote control, interfaces for the output to control unit, CD drive, and illumination are all integrated on one circuit board (CB) "CENTRALEINHEIT ES 5.1".

The music power per channel is 200 W when matched to a loudspeaker impedance of 4 Ω.

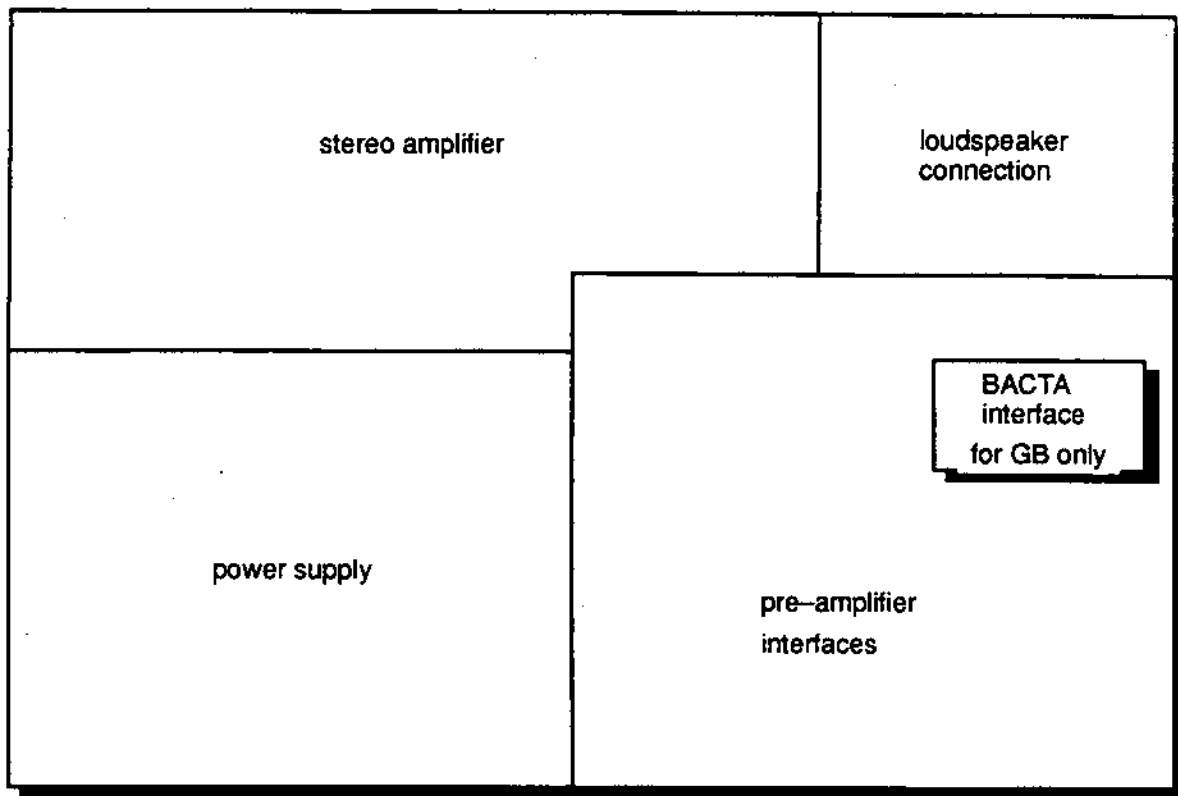

Figure 8: Structure of the Central Unit

**Control Unit**

This CB contains the microprocessor which controls all functions of the phonograph. Evaluation is performed with the phonographs keyboard and display or with data transfer via the serial interface connector located on this CB.

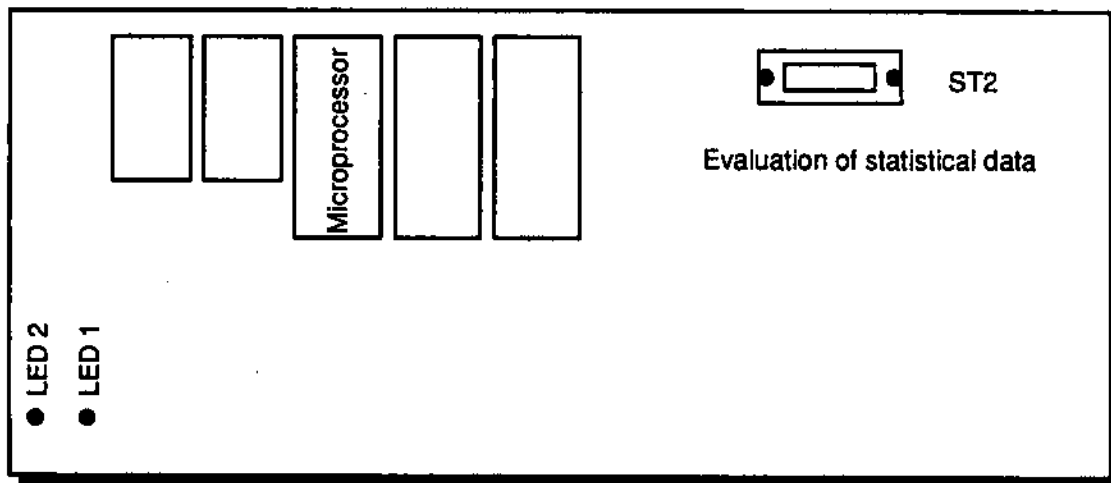
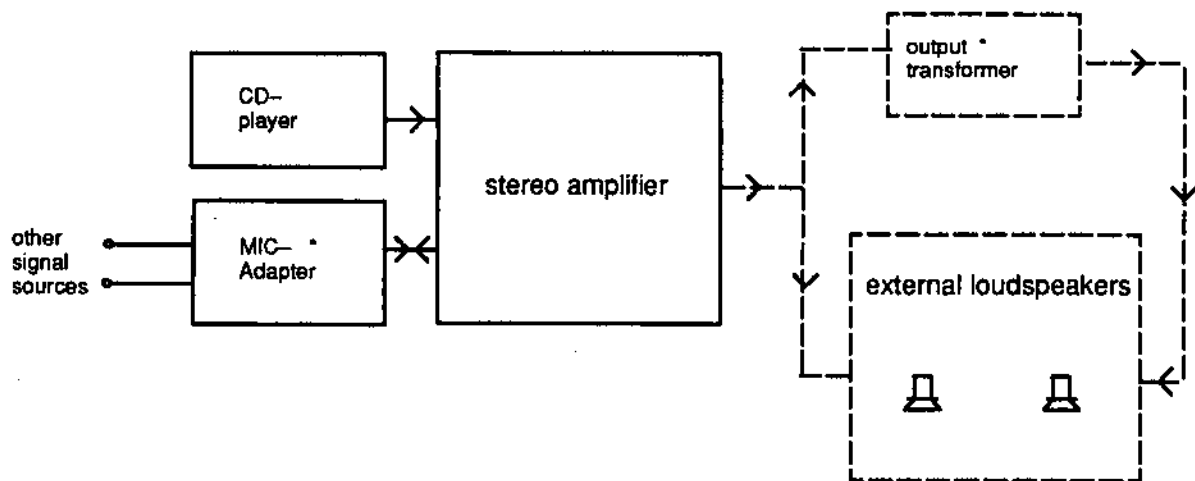

Figure 9: Structure of the Control Unit

**Audio system**

The audio system of this phonograph consists of the following main parts:

- CD player
- stereo amplifier
- output transformer



\* = option

Figure 10: Structure of the main components of the audio system

### CD changer

The CD changer used within this phonograph is the fastest 100 CD changer. This high quality product uses two CD storage magazines capable of storing max. 50 CDs each.

A simple locking mechanism is integrated to hold the two CD storage magazines.

Fold together the two halves of the handles (2) of each CD storage magazine.

Simply press the left button (1) to the left side and the right button (1) to the right side to unlock the corresponding CD storage magazine. Afterwards it will be released and you may take it out of the CD changer.

Refer to figure 11 to get familiar with this feature. You will need this knowlegde later when loading CDs.

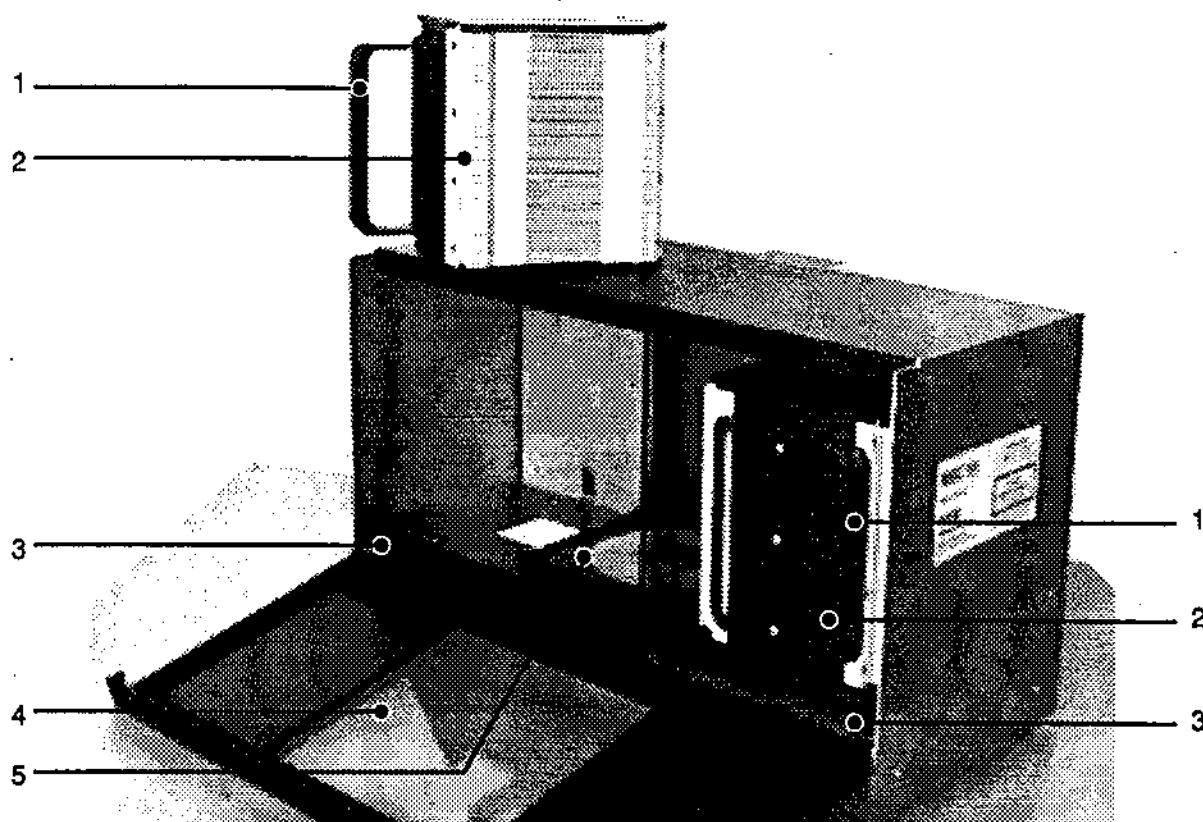

Figure 11: CD changer

The components are:

- 1 = Handle of the CD magazine
- 2 = CD magazine
- 3 = Locking lever for CD magazine
- 4 = Front door of the CD changer
- 5 = CD lift



## Options and accessories

### Key-Switch (part no.: 177 486)

A key switch on the rear side of the cabinet or on the side wall serves as protection against unauthorized calling up of the functions:

- free credits
- switching on the background mode

In position "key switch locked" settings from the remote control are disregarded. The position "key switch open" permits programmed free credits to be called up and the background mode to be switched on.

The key switch not being installed means the same as position "key switch open". This also permits to call up programmed free credits and to switch on the background mode. If this is not desired, the function generally can be locked or only be activated while a programmed time window becomes active.

### MIC Adaptor (part no.: 177 488)

Use this MIC-Adaptor for connecting a dynamic microphone with an impedance of 200-600  $\Omega$  or connect a tape recorder /-player resp. an additional amplifier. A detailed description is delivered with the MIC-Adaptor.

### Infrared Remote Control (part no.: 177 491)

This phonograph can be controlled via an IR remote control. The following functions are possible:

Volume	Free credit
Reject muting	Background

### Wired Remote Control 5m/20m (part no.: 177 490 / 177 489)

This phonograph can also be controlled via a wired remote control. The following functions are possible:

Volume	Free credit
Reject muting	Background

### DATaprint 3000 evaluation equipment (part no.: 118 197)

The printer is intended for connection to NSM phonographs. A detailed description is included within the printer.

### CD Safe (part no.: 176 104)

This CD-Safe offers a very easy solution to store and to transport your CD magazines. Stickers with positioning numbers are supplied for simple identification of the contents of the CDs on the CD-Safe and on the magazine.

### Cash counter, electro-mechanical (part no.: 173 348)

NSM phonographs can be modified subsequently with an electro-mechanical cash counter (12 V = pulse counter).

## Technical data of the phonograph

### Electrical Data

Mains voltage:		100–260 V (variable), 50/60 Hz
Power consumption	stand by	170 W
	play mode	350 W
Music power	4 $\Omega$ load	2 x 200 W
Sine wave power	4 $\Omega$ load	2 x 125 W RMS (Sinus)

### Lighting

Fluorescent lamps	4 W / 8W / 13 W
Lamps	12 V / 2 W

### Dimensions

Height	1005 mm = 39,6 inch
Width	650 mm = 23,8 inch
Depth	360 mm = 14,2 inch

Weight	nearly 83 kg = 170 lbs
--------	------------------------

### Credit / Cash Input

Maximum credit display is 99.  
 Price list adjustable.  
 Free credit adjustment / permanent credit.

### Keyboard

10 number keys	0–9
1 correction key	"C"
1 hit–step key	"H"

### Displays

Display 1 with 4 seven–segment LED's  
 Display 2 with 2 seven–segment LED's  
 Display 3 with 4 seven–segment LED's

1 lamp display each for "10 top hits", "background", "credit", "your selection", and "error, press key "C"

### CD changer

NSM CD changer for up to 100 CD's. Disc–player: Philips CD–player unit.

### Special Features

Computer–controlled amplifier protection for overload (mismatch).

# Section 3

## DIGITAL THUNDER WALL

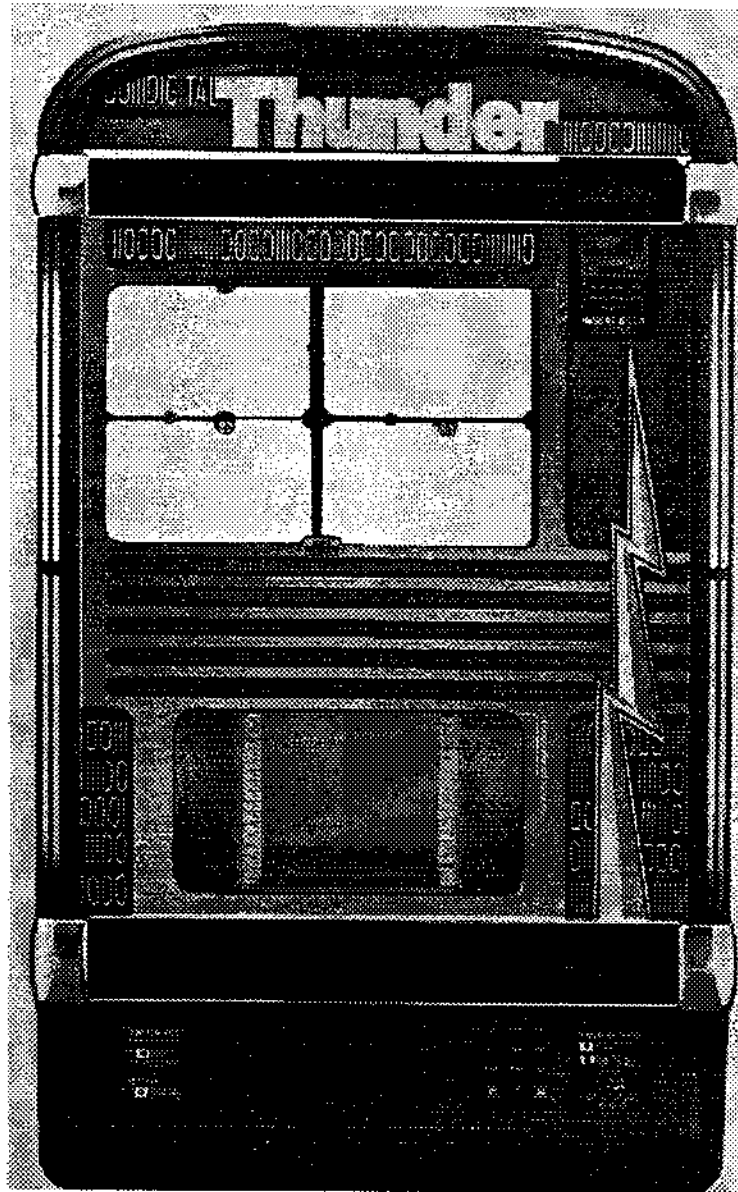

# Installation

## Section 3 Installation of the phonograph

This section describes how to set up the phonograph. You will get information about mains connections, loading CDs, and title display. When you have finished this section correctly your phonograph should play every selectable title.

### Important

To protect your phonograph or any connected device from any damages please regard:

Before you connect any device, or before you make any changes to the connection between the phonograph and a device, please make sure to switch off the power supply of the phonograph and any connected device (i.e. external audio amplifier). Otherwise damages may be caused to the phonograph and/or the connected device(s).

### Mains connection

**Note: Check mains voltage before connecting the phonograph!**

The label placed on the back side near the power connector shows the factory setting of the mains voltage.

For other voltages set the required voltage by re-wiring the corresponding wires of the mains transformer.

**The green-yellow wire of the three-wire power cord must be connected to the ground according to the international safety code.**

After plugging in the phonograph, turn on the power switch placed in the right hand recessed grip at the bottom of the cabinet.

The fluorescent lights and the running lights of the front glass design (flash) should now light up.

The phonograph is ready to operate now.

The next step is to load several CDs into the CD changer.

## How to load the CD storage magazines

Refer to figure 11 to find the location of the different types of locks used while loading CDs. In order to avoid movement of the lift (attract mode) while working within the CD changer pull out the service switch before working with the CD storage magazines. Now the phonograph is in service mode.

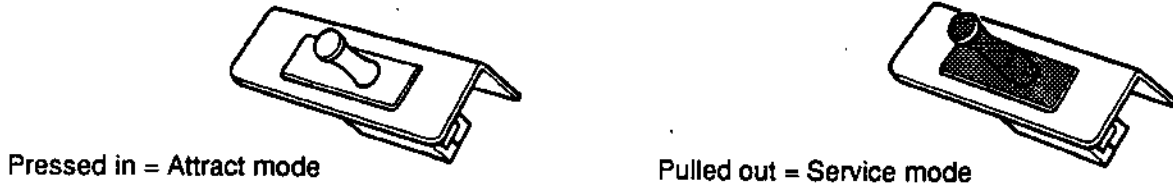

Figure 12: The Service switch

To load CD storage magazines open the front door of the CD changer. The front door will smoothly fold forward. When the door is totally opened fold the two CD storage magazines to the outside by pressing the corresponding black knobs to the inner side and folding the left magazine to the left and the right magazine to the right.

Remove the right-hand storage magazine by holding it with your right hand and pressing the right-hand, black knob to the right side.

Remove the left-hand storage magazine by holding it with your left hand and pressing the left-hand, black knob to the left side.

Remove a number of CD trays corresponding to the number of CDs you wish to insert into the magazine. Into the recess of each tray, place a CD face up (label up), and thereupon slide the tray into the first available slot of the magazine (see fig. 12 below).

Observe the sequence of the magazine and title strip numbers.

Take care to push in the CD trays until they lock in center and do not hinder the lift.

**Note:** CDs have to be placed **label up** into the CD trays. Otherwise the CD changer may cause an error when accessing an incorrectly inserted CD.

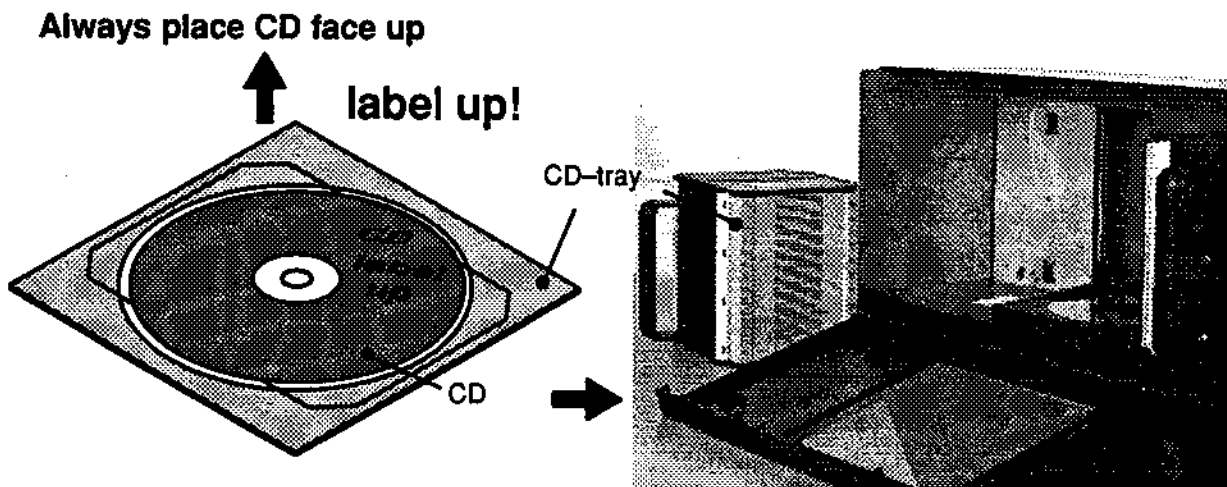

Figure 13: Placing CDs into trays

Return the two CD storage magazines by pushing them into the corresponding hinges and close the front door by latching it into its closed position.

**Note:** When transporting loaded magazines the CD's can be protected against falling out by inserting the red plastic splint from the transportation security through the magazines and all loaded CD's. Use the enclosed four metal clamps as transportation security devices for the CD-magazines.

## Loading the title display

The title display is designed to show up to four CD covers at a time. You can insert CD covers and title strips for up to 100 CDs maximum. The following procedure describes how to prepare the CD covers and the title strips for loading into the title holders.

Loading of black title holders should be done as follows:

Remove title pockets from the accessory package, insert the CD covers on the left side and the written title strips on the right side into the title pocket. **Put the thicker foil side of title pocket to the outside.** Then insert the title pocket into black title holder. If the covers are bigger than 120x120 mm, they need to be cut to size – please use only one page of the album cover.

The title holders are also moved by pressing the "TL" or "TR" buttons placed on the circuit board of the title display unit while inserting title holders.

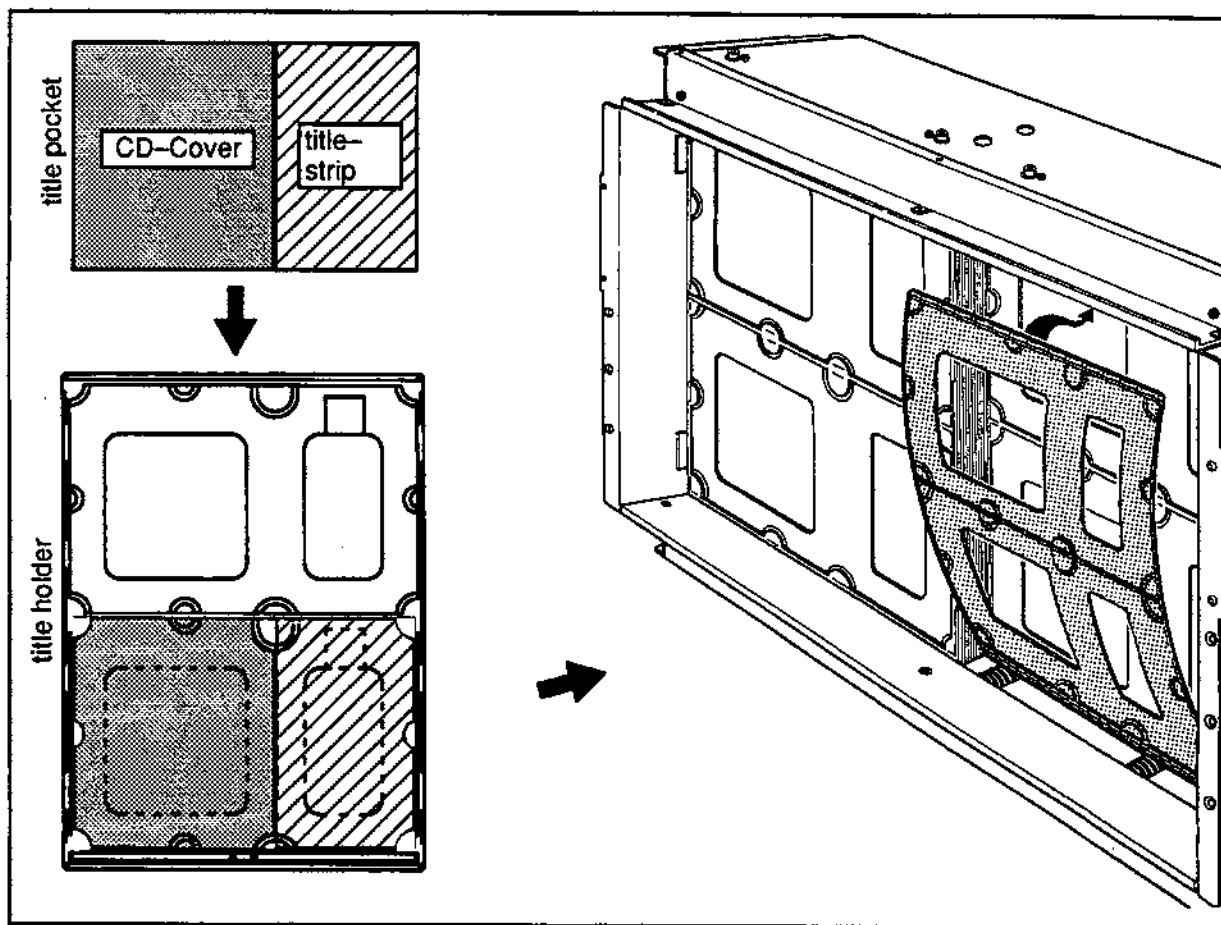

Figure 14: Loading of title holders

Additional titles strips and title pockets can be ordered using the following ordering informations:

**TITLE STRIP** Part-No. 219 185

**TITLE POCKET** Part-No. 212 509

**Take care of the placement of the title holders.** They must stay inserted in a specified sequence to guarantee a synchronous movement and correct display of titles corresponding to the CD number.

In case of dislocation of title holders due to rough transportation, please refer to the following figure to reorganize the sequence of it. See also figure 15.

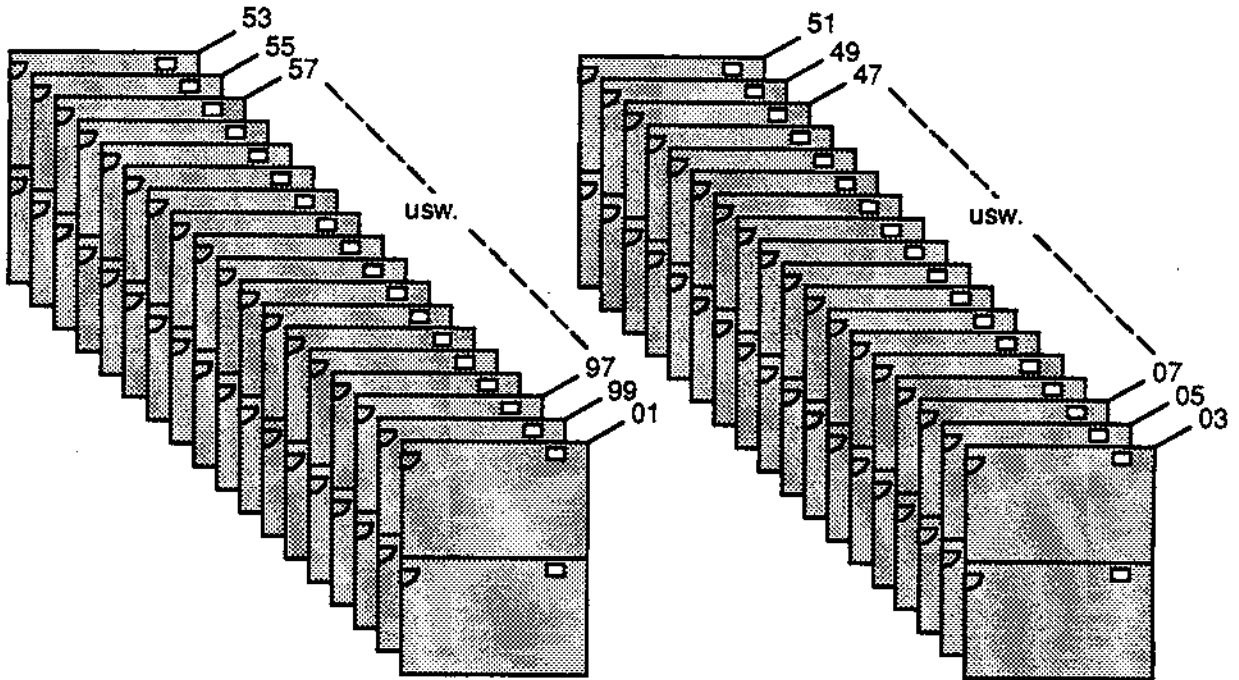

Figure 15: Sequence of title holders

## Synchronising the title holders

When all title holders are removed and the motor has turned, the synchronization has to be readjusted. During insertion of the title holders it is important that the pin of the counter wheel is positioned exactly in the center of the opto coupler "sync" ( I ). The belt drives for the title holders have to be in their end position ( II ). If this is not the case, one of the service buttons TL or TR has to be pressed until position I and position II are reached.

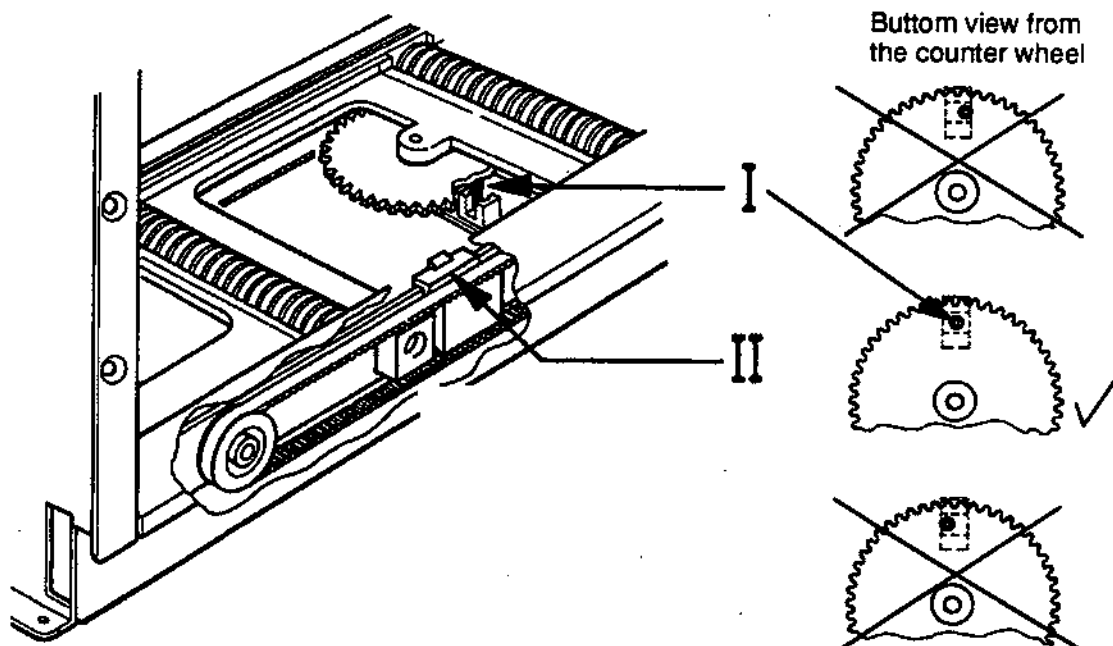

Figure 16: The synchronisation marks of the title display

Now the synchronization has the correct relation to the position of the title holders. The title holders have to be inserted into the worm drives starting from the rear end. In order to do this the title holder has to be bent slightly forward in the center until it fits in the guide (see figure 14). It should be started at the left rear end with "53" then "55", "57" etc. until "01"; on the right side it starts with "51", the "49", "47" until "03".

### Note:

Special care has to be taken during insertion that the first title holder has to be inserted into the last slot of the worm drive of the title indication. The next holder has to be inserted into the next slot directly in front of the previous. If you have accidentally skipped one slot, all following title holders have to be removed again.

A problem with the title display will initiate error code "ER 9x" appearing on the display on the front of the phonograph. Refer to the Service Manual to get more information about error locating or trouble shooting.



### Initialize the loaded CDs to the control unit memory

If the phonograph is not yet in service mode, you should open the cabinet lid and pull out the service switch (cabinet interlock switch) located at the top inside of the cabinet.

By changing the display, the phonograph indicates that it is in service mode. The display shows the following text:

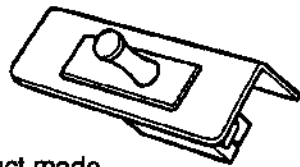

Pressed in = Attract mode

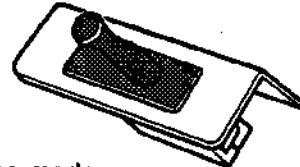

Pulled out = Service mode

After that the phonograph is in service mode. On the display you can see the following news:

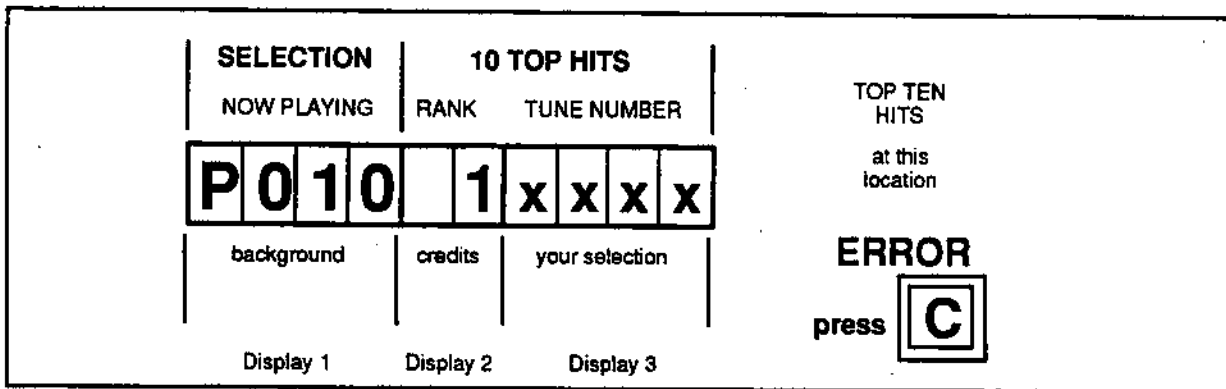

Figure 17: Display after entering the service mode

Now you should enter the command P160 to start the initialization. Perform the following steps:

press "C"	display shows P ___
enter 1 6 0	display shows P 1 6 0
press "H"	to execute the command

The control unit then checks every tray, one after another, of both CD storage magazines to read the information from the inserted CD concerning the number of tracks.

**Note:** The control unit searches all CD trays up to the number of CDs specified in P042. The factory setting of the value in P042 is 0024, which means 100 CDs with 24 tracks each. If you have not installed 100 CDs, you must first change the number of accessible CDs in P042. The number of tracks is calculated automatically with P160 afterwards.

Take care that you do not leave CD trays empty from the last tray (for CD no.100) downwards.

After starting the initialization routine the phonograph needs some time (up to 20 minutes) to check all CDs. During this routine you may close the cabinet door. The phonograph returns automatically to the normal play mode after finishing the initialization procedure.

### Ready to play using factory settings

When the phonograph has finished the initialization procedure it is ready to play with the pre-programmed factory settings.

Table 1: Factory setting values of the phonograph

P041	0	P047	0	P053	0505	P124	0
P042	0024	P048	0	P054	0808	P127	0
P043	1105	P049	2	P077	0	P134	0
P044	1000	P050	2	P094	0	P144	0
P045	0	P051	31	P104	0		
P046	0	P052	16	P107	0		

If you wish an individual programming for your phonograph, please refer to Chapter 5 "Programming of the phonograph".

## Section 4

# DIGITAL THUNDER WALL

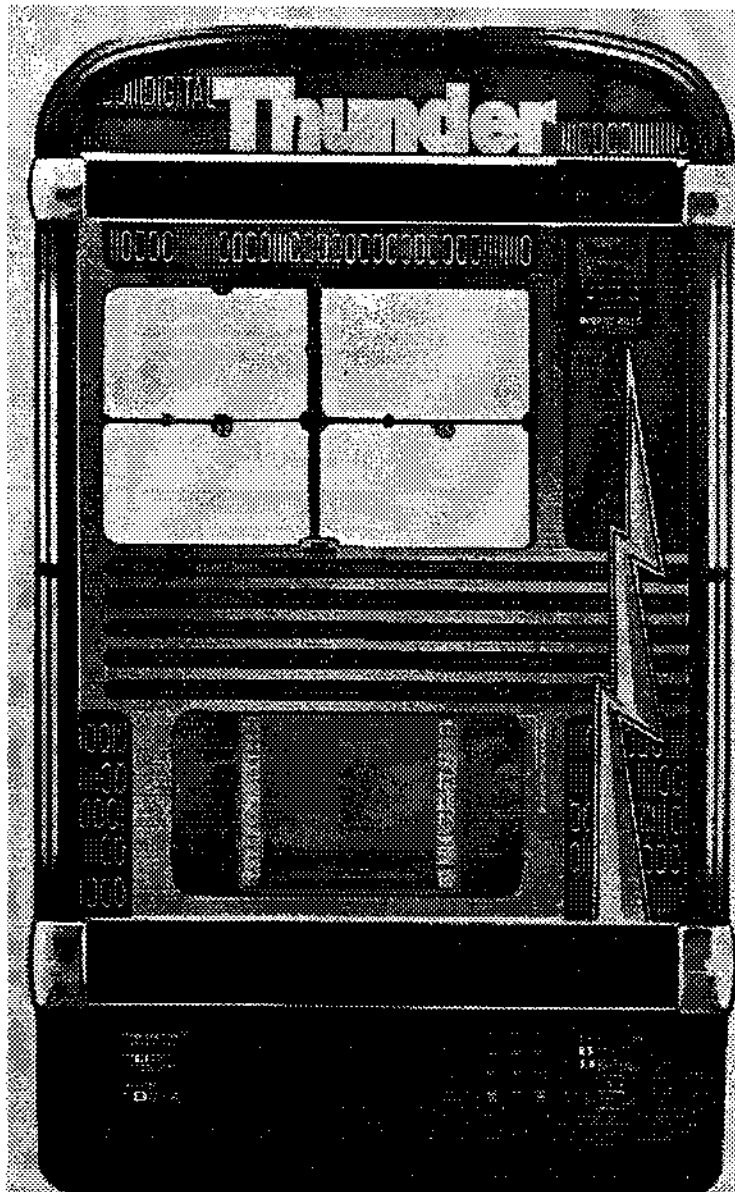

## Basic operation

## Section 4 Basic Operation

### Changing the price – and monetary value settings

With the help of the following tables you are able to quickly program defined prices for playing CDs. The detailed description and corresponding tables are contained in chapters "Price Settings" and "Monetary Value Settings" in section 5: "Programming".

The values defined within the program steps P060 to P065 (factory settings) are designed to meet the information written on the label of the front door of the phonograph.

If you want to change the price settings from the factory settings to individual ones, you have to perform the steps described in table 2.

Take care to change the label on the front door of your phonograph after changing the price settings.

#### Example of programming the price settings

Practical example for setting the "price settings":

- 1 play = 25 c
- 2 plays = 50 c
- 5 plays = 1 \$

Table 2: Programming of price settings:

Programming information	Action of the operator	Displays		
		1	2	3
Call up to service mode	pull out the service switch	P010	xx	xxxx
Entering command mode	Press key(s)		Play	price
	"C"	P		
Direct selection of a command, display of previous setting in P061.	"61", "H".	P061	xx	xxxx
New setting in P061 "1 play/25c".	"01", "0025"	P061	01	0025
Confirm setting and advance to next command, display of previous setting in P062.	"H"	P062	xx	xxxx
New setting in P062 "2 plays/50c".	"02", "0050"	P062	02	0050
Confirm setting and advance to next command, display of previous setting in P063:	"H"	P063	xx	xxxx
New setting in P063 "5 plays/1 \$".	"05", "0100"	P063	05	0100
Confirm setting and advance to next command, display of previous setting in P064:	"H"	P064	xx	xxxx
For only 3 classes setting "0".	"0"	P064	00	0000
Confirm setting and advance to next command, display of previous setting in P065:	"H"	P065	xx	xxxx
For only 3 price classes setting "0".	"0"	P065	00	0000
Confirm setting and advance to next command, display of current setting for P066 (album selection without discount).	"H"	P066		1

After confirmation of a setting (e.g. for P062) the system automatically turns to the next program step (here: P063).

**Caution!** Press "C" key in the event of incorrect programming or when display flashes.

If you want to terminate the changing of settings you have to press the "C" key twice or close the cabinet door to **return to standard operating mode (play mode)**.

### Example of Programming the monetary value settings

Depending on the type of coin acceptor the individual coin channels must be programmed for the associated monetary values in the corresponding program steps. Unused channels must be programmed with the monetary value "0".

**1. Checking the monetary value settings:** Select one program step between P070 and P075. After inserting a certain coin the channel associated with the coin is displayed, e.g. 50 cents in channel 2: display P072 0050.

**2. Changing the monetary settings:** As an example, the 25 cents slot (channel 1) is not to be used: First enter program step P071 as described above. In the coin acceptor or on the adaptor PCB of electronic coin acceptors the respective channel has to be blocked so that these coins drop into the coin return.

**3. Standard settings:** The programming of standard settings is done with the command P070 and entering the number of the desired table values (see table 8 "Monetary value settings" in section 5: "Programming"). The correct programming of all channels is done automatically after entering the number and pressing the key "H".

Table 3: Programming the monetary value settings

Programming information	Action of the operator	Displays		
		1	2	3
Direct selection of a command, display of previous setting in P071.	See text (2.)	P071		xxxx
New setting; no coin conversion	"0"	P071		0000
Confirm setting and advance to next command, display of previous setting in P072.	"H"	P072		xxxx
If the standard setting according to the table of monetary standard settings is to be used thereafter, call up program step P070 (as described previously).				
Ready for standard setting P071 through P075	See text (3.)	P070		xxxx
Program entry "26" of the standard table (for USA electr. acceptor).	"26"	P070		26
Confirm setting and advance to next command:	"H"	P071		xxxx

**Caution!** Press "C" key in the event of incorrect programming or when display flashes.

If you want to terminate the changing of settings you have to press the "C" key twice or close the cabinet door to return to standard operating mode (play mode).

### The "Credit" button

The phonograph also offers a so-called **free-credit button**, located below the mechanical coin acceptor or on the CB adaptor (see fig.18) with electronic coin acceptors. Action on this button is only possible when the phonograph is in service mode. Pressing the credit button once gives "1 free credit". Credits generated by pressing the credit button are not registered statistically.

## Settings for the coin mechanism with electrical coin acceptor MARS

This phonograph can be equipped with an electrical coin acceptor. Then 4 or 5 different coins will be checked depending on the type of the coin acceptor installed.

The three sensors in the validator register each separately thickness, material quality and diameter of each deposited coin. If a deposited coin has passed the sensors, the measured data are compared with the stored information of valid coins (PROM).

If validation criteria are identical with a data set of the PROM, an internal "valid" signal is produced. Depending on the coin value it is sent as output signal A1 to A5 to the plug of the CB ADAPTOR. From there the signal reaches plug ST8 of the control unit. Refer to figure 18 and compare the following informations.

The monetary value settings of the individual program steps are assigned to corresponding output signals:

- P071 to signal A1 or A5 \*
- P072 to signal A3
- P073 to signal A4
- P074 to signal A2

\*depending on position of jumpers A5/1 and A5/5 the signal A5 of the electrical coin validator is assigned to P071 or P075.

**Note:** When inserting a coin during program steps P070 – P075, the program step assigned to this coin is automatically represented in display 1.

The monetary values are programmed in monetary value units:

"0100" ^ 1,- \$, "025" ^ 25c, "0050" ^ 50c.

To avoid misuse or manipulation non-used channels are to be programmed with "0"!

Non-used channels also can be blocked mechanically. For this purpose the bridge of the corresponding channel (IA1 to IA5 on the CB ADAPTOR) has to be disconnected.

With 4-channel coin validator signal line A 5 is not connected.

When exchanging the control unit the programming has to be done in the new unit also.

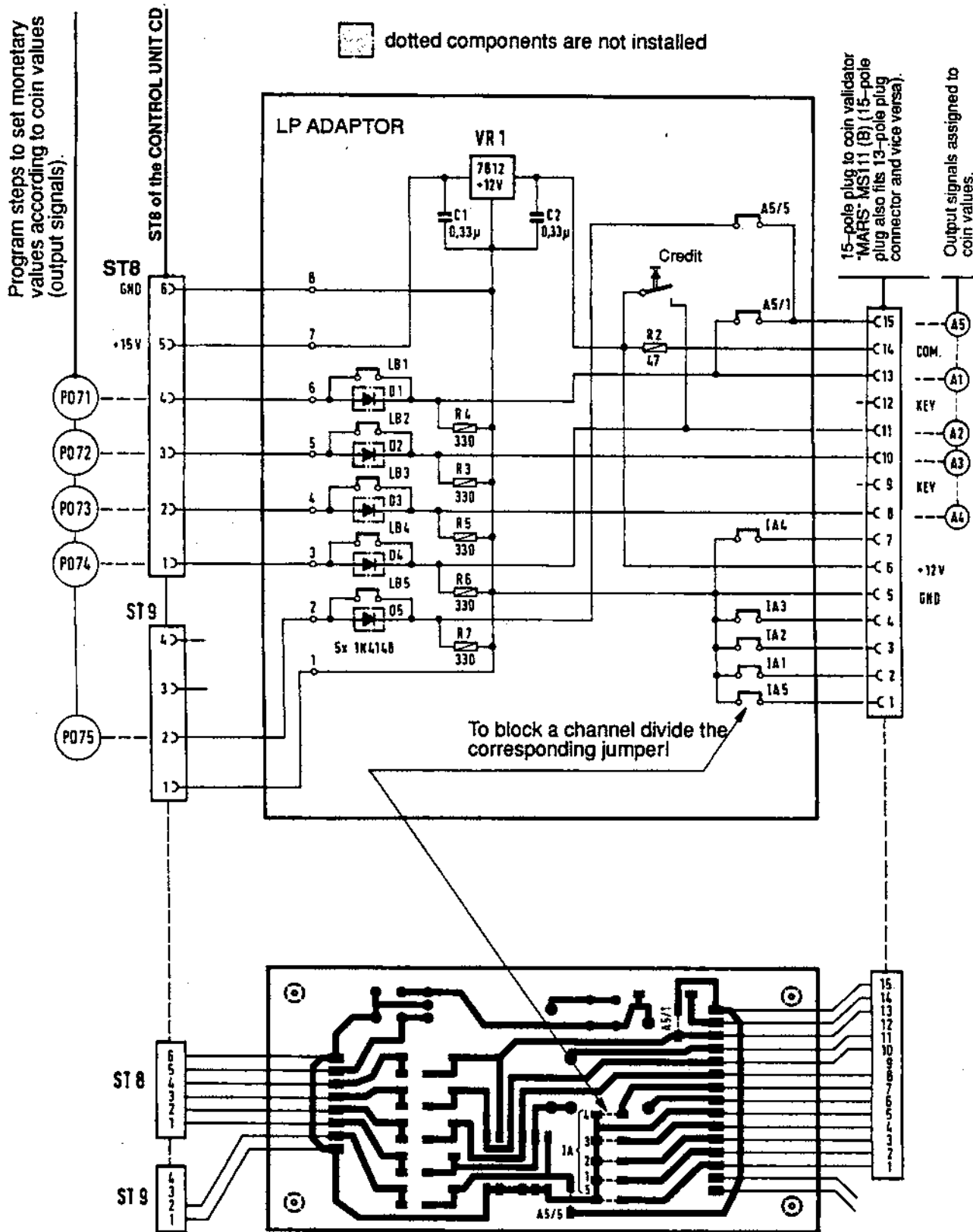

Figure 18: Wiring diagram and layout of the CB Adaptor

## Summary of programmable features

This phonograph is equipped with a wide functional "Service Program" to allow a lot of individual settings.

In the following we only give a short overview of the possibilities provided by the service program of the phonograph.

### Play Mode

Your selection is stored temporary in the selection storage. After selection of a title the CD which is to be played is transported to the player and then played.

Just before the start, the number of the title is shown on display 1 ("selection now playing"). After the disc has been played, the display is cleared and the CD is transported back to its magazine space.

Note: If an error occurs within the CD changer or the player, "Er 7x" or "Er 6x" appears for 2 sec. Refer to the Service manual to get more information about error locating or trouble shooting.

### To limit the playing time for a title (track)

By programming P045 the maximum time that a title is to be played can be set in minutes.

After expiration of this time the volume of that title is faded out and then muted.

If you program "0" (factory setting), there is no limit in playing time.

### Sequence of playing titles

By programming P046 you can set the sequence of the selected titles.

Settings:       0 = in sequence of selection (FIFO)  
                  1 = in numerically increasing sequence  
                  2 = random sequence

### To limit the playing of titles on the same CD

Using the programming of P047 you may define how many titles can be played consecutively on the same CD.

If you program "0" (factory setting) there is no limit.

### Autoplay mode

A time interval can be set by programming the command group P 11x for playing incentive titles.

Conditions for an incentive title to be played:

- Phonograph in standby mode
- No credit available
- Microphone switch not being used
- No muting

## Attention!

When playing a test-CD, the description that comes with the test-CD should be followed exactly. However, do not give sine signals with peak signal "0dB" at full volume level to the loudspeakers for more than 1 sec.

Other unfiltered noises and high-frequency signals (which are only used for measuring purposes) can also damage the amplifier and loudspeakers at full volume.

When checking channel separation, it has to be verified that the box is not switched to "Mono-mode" (refer to **Mono mode operation**).



## Credits

Credits remain stored during "power off/on" (P049 = 0).

If the control unit detects no activity on the phonograph within a set time, the stored credit is cancelled (P049 = time).

## Title display

By pushing the rocker button of the front door, respective title holders are moved into the corresponding direction. Upon each key operation two new CD covers including title strips are shown. If selectable CDs have been limited by programming with command P042 only the corresponding title holders are shown.

## Background Music

You also have the possibility to play music in the background. In order to encourage the public to make selections, background music can be programmed to be active on specified days and times. The programming of background music titles is done with the group P10x of the service program.

## Advertising

With the commands of group 12x of the service program it is possible to define time slices for playing special CD's containing advertising information (ad).

While the ad-mode is active a title is played every n minutes (n is the time defined in P124) after the currently played title. The CD's containing ad can be selected for "not to be played by normal customers" (P126).

## Lock-out titles

If one title of a CD is bad it can be locked out for a defined time for every single day by programming the steps in group P13x of the service program.

A lock-out title can be defined by

- bad quality of reproduction
- bad track within the title
- shocking information.

## Happy-Hour credits

Happy-Hour can be programmed to be active during several days. The programming of Happy-Hour is done with the group P14x of the service program.

When active an additional bonus credit is given if the customer has payed for a number of credits (defined as calculation number in P144). For example: after 5 payed credits one Happy-Hour credit is given if the calculation number is programmed as 5.

## Service and maintenance

With the commands of groups P15x and P16x of the service program you can

- read out errors of the phonograph including CD number and date of appearance,
- test the CD changer,
- test the CD played,
- test the lamps and keys,
- install new CDs
- remove bad or not-up-to-date CDs.

## Adjustments with Remote control

The phonograph can optionally be equipped with cable-type remote control or infrared remote control. All functions and the operation of both models are identical. Therefore, this description is valid for both of them.

The buttons "+" or "-" attached to the rear of the cabinet allow a common adjustment of volume for both channels. By pressing "REJECT" you can return the CD actually playing.

These three functional buttons attached to the phonograph correspond to the function of the buttons I+II, and REJECT on the remote control.

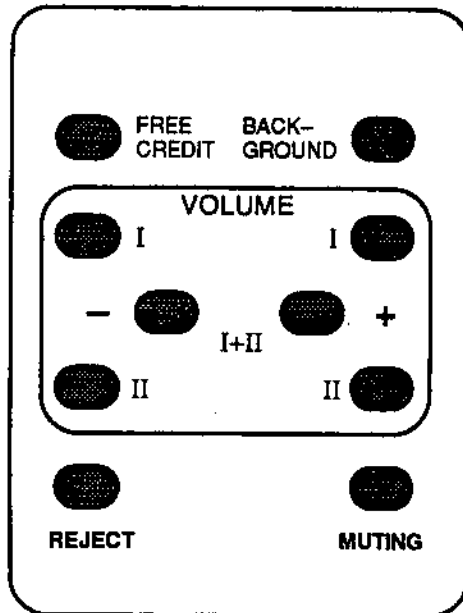

Figure 19: Remote control

### Volume controls

We differentiate between two volumes:

- The "normal volume" of selected titles and random play titles
- The "background volume" of background titles

For selected titles and random titles or with microphone and tape mode the corresponding volume is adjustable; background volume only with background mode. The keys have the following meaning:

- Keys "I" for the left channel
- Keys "II" for the right channel
- Keys "+" (laterally attached) for increase of volume
- Keys "-" (laterally attached) for decrease of volume

When pushing the center keys "I+II" (red) the channels are regulated together. If they were differently set, they are first "balanced" and regulated together.

When no selection is taking place, the volume for the channels is shown on display 3 during the adjustment in steps of "1" to "31".

While "Muting" is active the message "OFF" appears in display 1. No more titles will be played until "Muting" is cancelled by pressing "Muting" again.

The last volume set is stored during "power off".

The maximum possible volume for normal and background mode can be limited by programming P051 and P052 in steps of "1" to "31".

**Note:** To protect the amplifiers a check is made whether an overload occurs due to mismatching. Upon recognition of an error the volume of the corresponding channel is reduced step by step automatically by the computer until a non-critical point is reached.

### **Muting**

The volume of both channels can be set to "0" by pressing the key "MUTING". The message "OFF" appears on display 1. Another pressing of the key "MUTING" or pressing one of the "VOLUME +" keys causes the system to switch back to the previously set volume for both channels.

**Note:** With display "OFF" no more records are played until "Muting" is cancelled.

### **Free credits**

Free credits programmed in program step P094 can be called up. The following free credits are possible depending upon the settings in step P094:

- Number of set free credits can be called up individually one by one
- Unlimited free credits can be called up individually one by one
- Permanent credit (free play) when pressing key "FREE CREDIT" for the first time (credit display "99"). When key "FREE CREDIT" is pressed again, permanent credit is blocked
- Permanent credit automatically within the time window

By using the program steps P091 to P093 a time window can be defined. While this time window is active free credits can be called up.

If no time window is defined any number of free credits can be called up.

### **Background music**

The background mode can be switched on with the "BACKGROUND" key. "Background playing" lights upon the display panel.

When pressing this key again, the background mode is switched off. In the background mode "random" records are played as defined in P105.

The time at which background music is to be played can be set in P10x.

The records are played at a "specific" background volume which can be changed as desired during playing.

A "normal record", selected while background music is playing, interrupts the background disc and the selected tune is played at "normal volume".

## Changing CDs and evaluation of the statistics

### How to change CDs

- "REJECT" a still playing CD
- Open the phonograph and pull out the push button (service switch) to enter the service mode. Display 3 automatically shows the least played CD.
- By pressing key "1" repeatedly, each time the number of the next best CD is displayed.
- Open the CD changer. Unlock the CD magazines and fold them out. Pull out the corresponding CD trays (holders) to change CD's. After changing a CD push back CD tray until it locks in. Close the changer after having changed the last CD.
- The title information of the new inserted CDs must be read into the phonograph by using the command P161. You may also use P160 if you have finished the service mode.
- Change corresponding title strips, unlock title display unit and fold down carefully. Put the desired title strips and covers in position. If necessary move the title holders by pressing the buttons "TR" or "TL" placed on the CB at the right-hand side of the unit.
- After loading is finished call up P160.  
The read-in of all CD title information is continued after the cabinet lid is closed. If the read-in was completed the programm automatically returns to the normal play mode.

### How to evaluate the statistics

- "REJECT" a still playing CD
- Open the phonograph and pull out the push button (service switch) to enter the service mode. Display 3 automatically shows the least played CD.
- Press key "C" to clear display. Display 1 shows "P". Enter the following commands:
- Read counters:
  - P013 = Cash total
  - P016 = Counter for plays
  - P017 = Number of selected titles
  - P018 = Number of selected albums
  - P019 = Number of overplay titles
  - P020 = Number of payed credits
  - P021 = Number of free credits provided
  - P022 = Number of background titles played
  - P023 = Number of autoplay titles
  - P024 = Number of advertisement titles
  - P025 = Number of Happy-Hour credits
- Erase counters:
  - P033, and selected code number: **ATTENTION!!!**
  - 0 und H = delete all memory contents
  - 1 und H = delete hitparade (P012)
  - 2 und H = delete popularity (P010)
  - 3 und H = delete all cash counters (P013 - 025)
  - 4 und H = delete credit memory
  - 5 und H = delete selections
  - 6 und H = delete error messages

You also have the possibility to make a print out of the statistical informations of the phonograph. Therefore you need the NSM DATAprint model statistics collector/printer, which is connected to the evaluation socket on the control unit of the phonograph.

**Data transfer and storage**

- Enter the service mode by opening cabinet and pull out service switch manually, display 1 shows "P010".
- Put in printer connector into the 9 pin socket "EVALUATION" of the Control Unit.
- Press "C", display 1 = "P".

**Print-out in text mode**

- Enter "30" and "H", display 1 = "P030".
- Enter Code "0" and "H". Counters + Errors, as well as popularity are transferred into the DATApriint.

**Print-out in graphic mode**

- Enter "31" and "H", display 1 = "P031".
- Enter code for the desired print-out:
  - 0 = complete information
  - 1 = all cash counters
  - 2 = all counters
  - 3 = settings
  - 4 = popularity
  - 5 = hit parade of this location
  - 6 = last 20 error messages

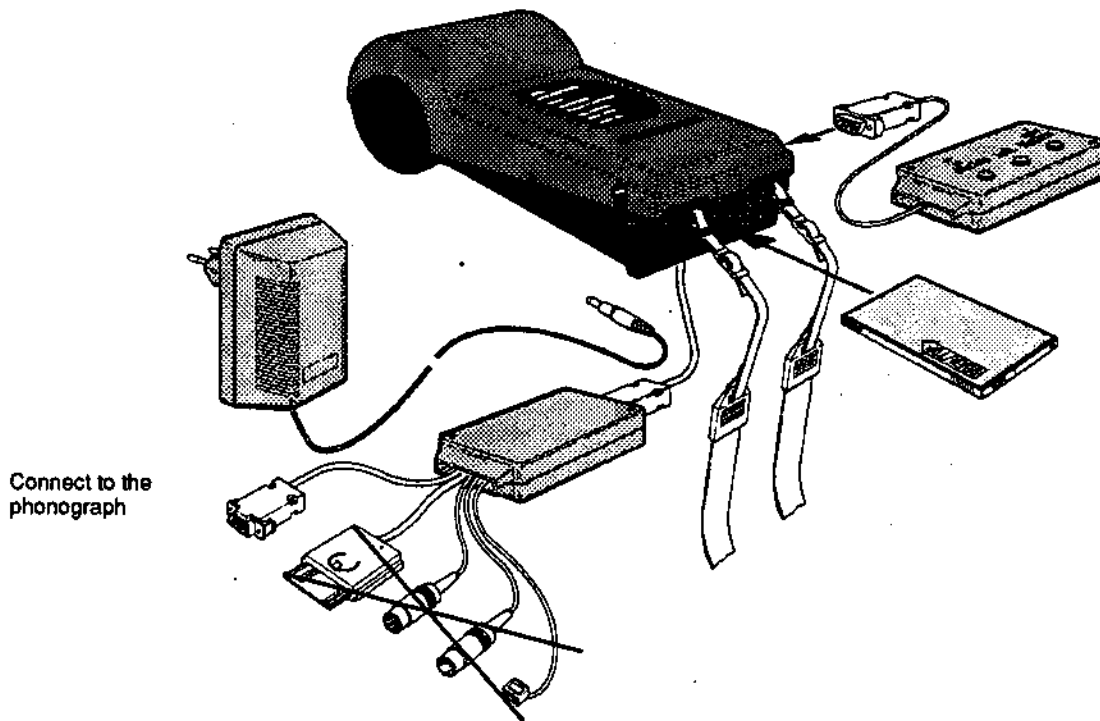

Figure 20: Evaluation using the NSM DATApriint

**Note:** If an error occurs during data transfer or if the printer does not start, "E0" appears on display 3. When a popularity counter has reached value 200, all popularity counters are divided by half. After dividing, the popularity printed out is relative. The number of divisions appears in the print-out: "RELATIVE 000" to "xxx".

**Attention:** After the data transfer has been finished successfully the memory contents of the phonograph are cleared if the service switch is pushed in when the cabinet lid is closed.



## Connecting loudspeakers

### Stereo mode

The connection wires of the loudspeakers are led through the opening in the rear side of the cabinet to the inside and then to the connection terminals of the output stage.

**The polarity ▼ must be maintained because otherwise bass reproduction would nullify itself!**

The stereo amplifier of this phonograph provides an output of 200 W music power at 4 Ω per channel (= 125 W RMS). The impedance of connected loudspeakers should be 8 Ω, therefore they will use 100 W music power from the amplifier, only half of the available power.

Additionally connected loudspeakers (refer to figure 22) also shouldn't have an impedance of less than 8 Ω. Otherwise the amplifier would be "mismatched" and the overload protection would operate.

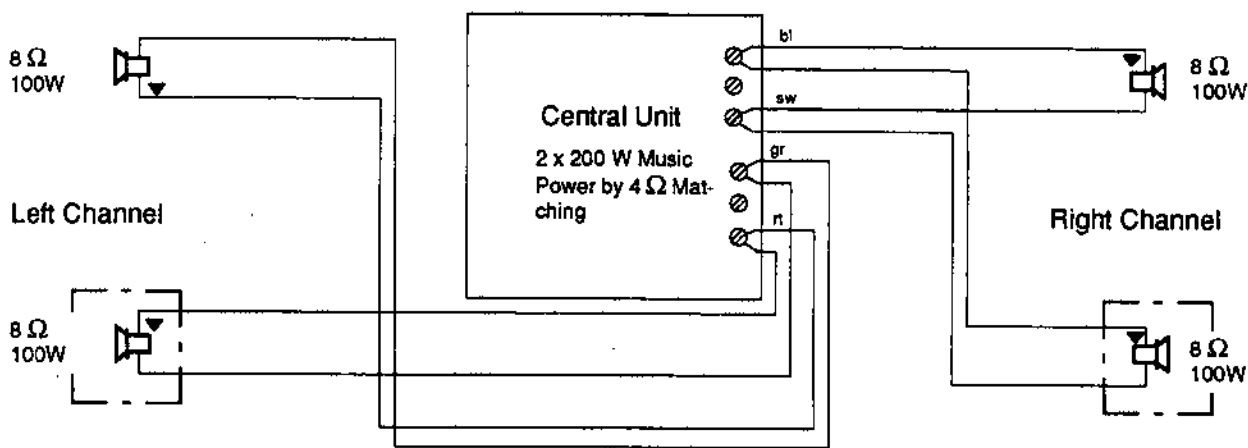

Figure 22: Stereo mode with normally connected loudspeakers

### Connecting loudspeakers of higher impedance

If loudspeakers of a higher impedance are connected (refer to figure 23), a number of speakers can be connected parallelly. In that case, a loudspeaker of a higher impedance would naturally be lower in volume.

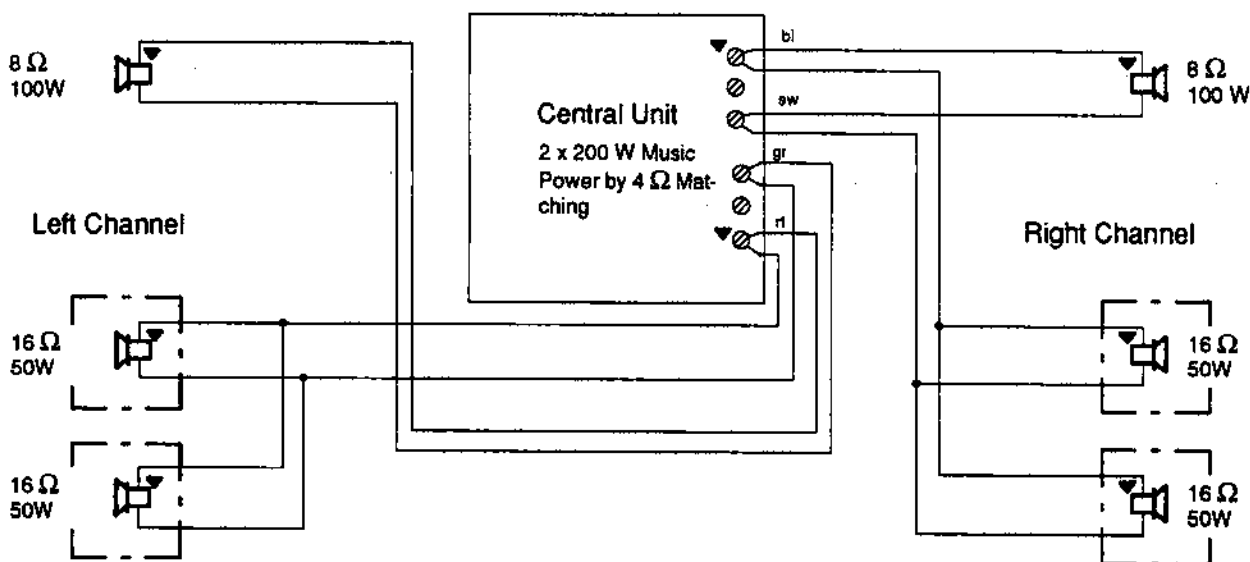

Figure 23: Stereo mode with connected loudspeakers of high impedance

## Mono mode

### Sound system for separate rooms

If the volume is to be controlled independently for 2 rooms, the loudspeakers of the first room can be connected to one channel. The loudspeakers for the other room can then be connected to the second channel (refer to figure 24). The switch S1 "Mono/Stereo" located on the CB "Central Unit" has to be switched to "MONO" (refer to **Location of the mode switch**). For this independent procedure a volume control with separate controls is necessary (refer to **Remote control operation**).

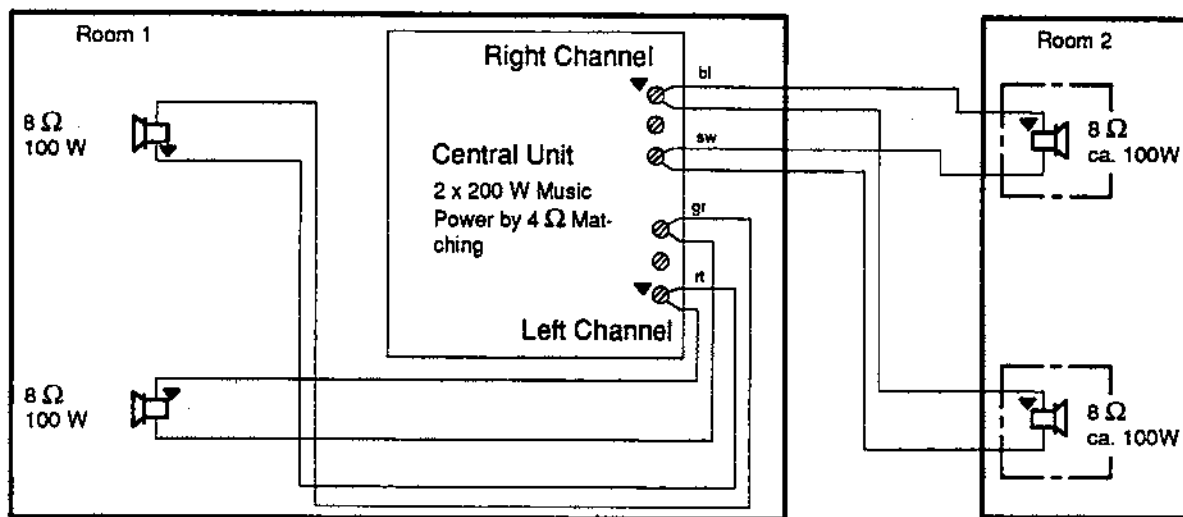

Figure 24: Mono mode with connected loudspeakers for seperated rooms

### Mono mode with serial connected loudspeakers in one room

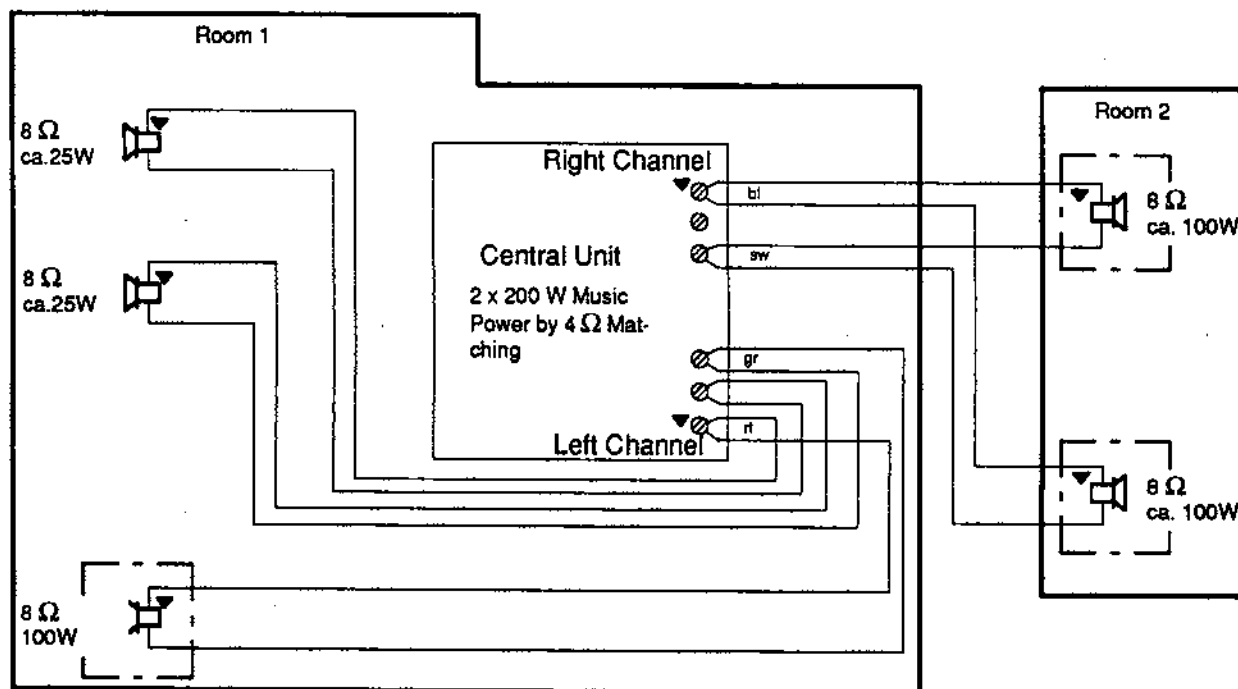

Figure 25: Mono mode with serial connected loudspeakers in one room



**Adjustments for better sound quality**

**How to get best room sound:**

Using the service program (command **P054**) you can adjust the phonograph's sound settings for different kinds of room sound effects. Here treble and bass are set for both channels at the same time. The changed setting is immediately heard.

**Key pad layout for sound setting:**

▲ more bass 1	▲ more bass + treble 2	▲ more treble 3
4 mean value	5 mean values	6 mean value
▼ less bass 7	▼ less bass + treble 8	▼ less treble 9
C Cancel	0	H Step to the next command.

Example for moderately-absorbent rooms:

Enter: **P 054 H**

Change per pressing keys  
i.e. key "8" = less bass and treble



standard value of bass, treble

Example for non-absorbent rooms:

Enter: **P 054 H**

Change per pressing keys  
i.e. Key "2" = more bass  
i.e. Key "9" = less treble

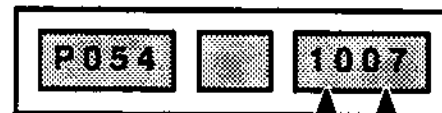

value of bass, treble

**Additional amplifier:**

An auxiliary amplifier can be connected for independent stereo control of other rooms as well as for increased power requirements.

**Location of the mode switch**

NSM phonographs can be operated in different modes: stereo, mono or S-Stereo.  
S-stereo simulates a base wide sound system for better stereo sound effects.

The mode switch S1 used for this purpose is placed on the CB CENTRALEINHEIT ES 5.1.  
Just move the switch into the desired position.

The factory setting is "STEREO".

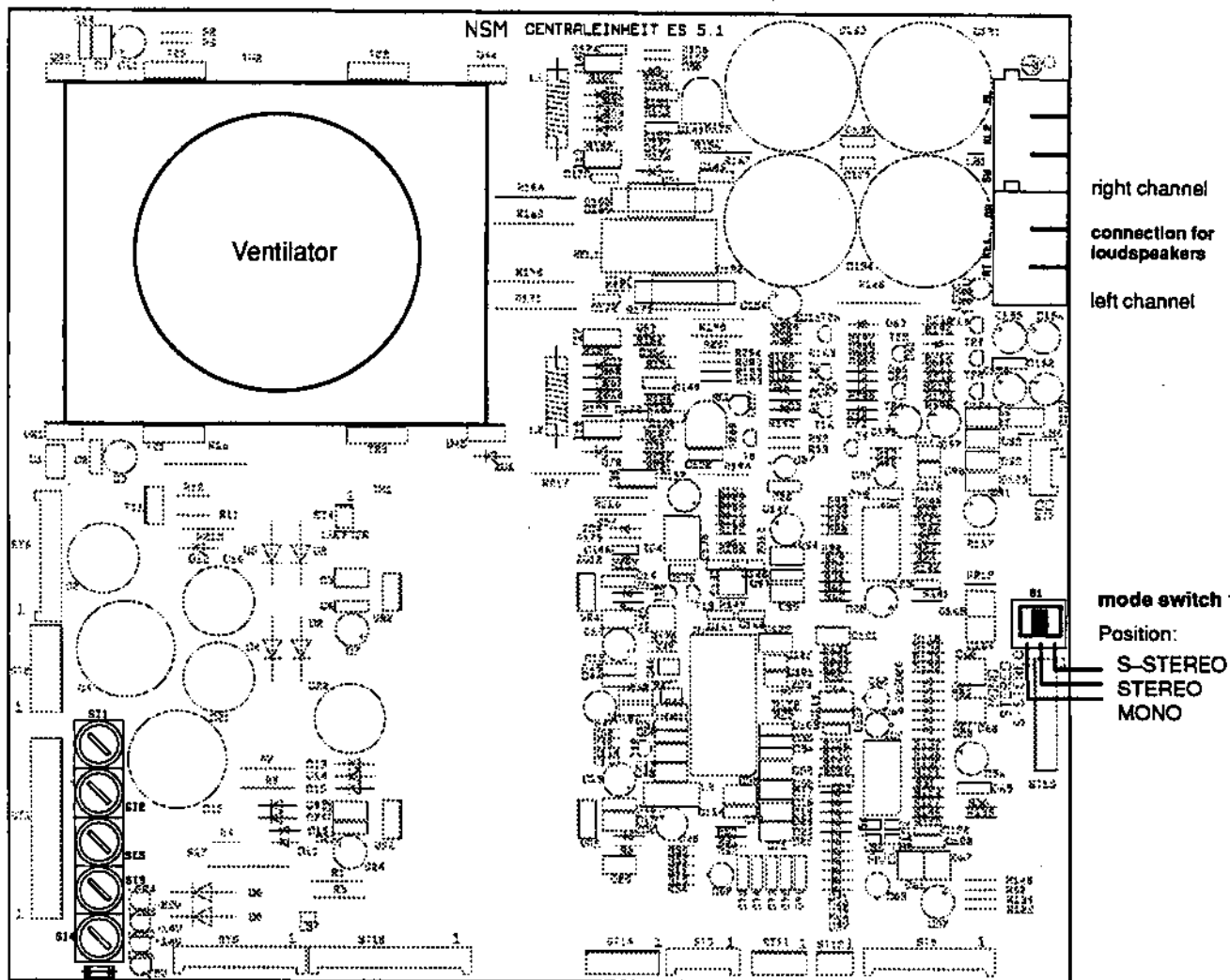

Figure 26: Mode switch S1 placed on the CB CENTRALEINHEIT ES 5.1

## Connecting loudspeakers via output transformer

If you want to connect more external loudspeakers to the phonograph so that the total impedance will be less than  $4\ \Omega$ , you have to connect the output transformer in order to avoid destruction of the output stage or distortions. See also the diagram "Loudspeaker Connection" at the end of this chapter.

### Extension Loudspeaker Operation

To avoid a poor-sounding phonograph, take care when adding extension loudspeakers. Regard the following requirements:

- 1.) Loudspeakers must be wired in a way that the power consumed by the extension loudspeakers (including remote selectors) does not exceed the amplifier power rating.
- 2.) Extension loudspeakers should produce the desired sound level.
- 3.) All loudspeakers must be connected with the correct polarity.

Several tables have been included to assist you with connecting the extension loudspeakers. The diagram at the end of this chapter shows the entire sound system.

#### Low Impedance Loudspeakers

##### 4 $\Omega$ -loudspeakers

No more than one  $4\ \Omega$ -loudspeaker should be connected to one loudspeaker line. If several  $4\ \Omega$ -loudspeakers are to be used, each loudspeaker should have its own line.

##### 8 $\Omega$ -loudspeakers

Low impedance loudspeakers with  $8\ \Omega$  can be used if the connecting cable is less than 100 feet long. The loss on 100 feet of connecting cable (type: AWG 18/0,75 mm<sup>2</sup>) feeding one  $8\ \Omega$ -loudspeaker is 15 %. The loss for two  $8\ \Omega$ -loudspeakers is 30 %.

**Do not connect a low impedance loudspeaker to a loudspeaker tap that exceeds the loudspeaker's power rating.**

##### 70 V-loudspeakers

To avoid possible cable losses on long loudspeaker lines, 70 V-loudspeakers should be used as much as possible. The power level in the 70 V-loudspeakers is set at each loudspeaker with its internal transformer.

#### **CAUTION:**

In any loudspeaker installation, the sum of the power ratings of all loudspeakers must not exceed 250 W RMS (sine wave power, 125 W RMS per channel).

Music power: Often there are two values given as technical data of loudspeakers:

Besides the sine wave power (RMS) also the allowable peak load (music power) is given.

The music power can be calculated as follows:

Multiplying the sine wave power by the value 1.6 results in the value of the music power (e.g. 125W RMS x 1.6 = 200W music power).

## Selecting loudspeaker power

General Instructions

This section will lead you through the process of selecting loudspeakers and their power consumption. This process consists of four major steps and several smaller steps. The major steps are:

- 1.) Identifying the extension loudspeakers and calculating their power.
- 2.) Making the external loudspeaker connections.
- 3.) Connecting diagram for output transformer.
- 4.) Checking the external loudspeaker connections (overload).

**Definition of extension loudspeakers and calculation of their power consumption**

- 1) Use a pencil (you may want to revise your entries) to write data to the work sheets on the following pages.

Use table 4 to calculate the amount of power consumed by the extension loudspeakers.

- 2) Note the quantity of 4  $\Omega$ -loudspeakers in the space of the column "Quantity".  
**Enter stereo loudspeakers as two speakers.**  
Multiply the quantity with the power consumption.

Place your results in 4) at the space "Total".

- 3) Afterwards note the quantity of 8  $\Omega$ -loudspeakers in the same manner.

Then also note the quantity of 70 V-loudspeakers.

Note the results of the corresponding calculations also in 4) at the space "Total".

Table 4: Calculation of the loudspeaker's power

<u>4 Ω–stereo–loudspeakers</u>		*) values given in W RMS	
	Quantity	Power consumption	Connecting taps
loudspeaker for 1,0*) W:	___ each 1,0 W	= ___ W	(E1 and E2)
loudspeaker for 4*) W:	___ each 4 W	= ___ W	(E1 and E3)
loudspeaker for 16*) W:	___ each 16 W	= ___ W	(E1 and E4)
loudspeaker for 28*) W:	___ each 28 W	= ___ W	(E1 and E5)
loudspeaker for 62*) W:	___ each 62 W	= ___ W	(E1 and E6)
loudspeaker for 125*) W:	___ each 125 W	= ___ W	(E1 and E7)
<b>4 Ω–loudspeaker</b>	<b>Total</b>	<b>= ___ W</b>	
<u>8 Ω–stereo–loudspeakers</u>			
	Quantity	Power consumption	Connecting taps
loudspeaker for 0,5*) W:	___ each 0,5 W	= ___ W	(E1 and E2)
loudspeaker for 2*) W:	___ each 2 W	= ___ W	(E1 and E3)
loudspeaker for 8*) W:	___ each 8 W	= ___ W	(E1 and E4)
loudspeaker for 14*) W:	___ each 14 W	= ___ W	(E1 and E5)
loudspeaker for 30*) W:	___ each 30 W	= ___ W	(E1 and E6)
loudspeaker for 62*) W:	___ each 62 W	= ___ W	(E1 and E7)
<b>8 Ω–loudspeaker</b>	<b>Total</b>	<b>= ___ W</b>	
<u>70 V–loudspeakers</u>			
The variable power selection for 70 V–loudspeakers is performed at the corresponding transformer integrated in each loudspeakers cabinet.			
Add the power consumption of all 70 V–loudspeakers and note this total value:			
<b>70 V–loudspeaker</b>		<b>= ___ W</b>	<b>(A1 and A2)</b>

4) After you have calculated all the necessary values you have to add them to get the

**Total power consumption of external loudspeakers:**

Total power consumption of 4 Ω–loudspeakers \_\_\_\_\_ W  
 Total power consumption of 8 Ω–loudspeakers \_\_\_\_\_ W  
 Total power consumption of 70 V–loudspeakers \_\_\_\_\_ W

**Total power consumption of all external loudspeakers \_\_\_\_\_ W in STEREO.**

This is the necessary power consumption which the amplifier of the phonograph at least must supply for external loudspeakers. This value must be less than the maximum power consumption of 250 W RMS (400 W music power). If it exceeds 250 W RMS you have to reduce the number of connected loudspeakers. Afterwards calculate it once more.

**NOTE:**

The amplifier may be rated up to 250 W RMS before the delimitation will start.

**Connecting the loudspeakers**

The connection between the amplifier of the phonograph and the output transformer is realized using coloured wires. The **red** wire is used to connect the left channel and the **blue** wire is used to connect the right channel. The **black** wire and the **grey** wire are used as the corresponding reference potential (ground). The ground wires are always connected to the tap E1 (ground) of the output transformer.

Refer to the table 5 to select output taps for more or less power for the connected loudspeakers.

**Power calculation for the internal loudspeakers**

Table 5 gives the loudspeaker power of the internal loudspeakers depending on the connecting tap of the output transformer.

Use less power for less volume.

Table 5: Selecting power at the output transformer

Loudspeaker power	Connect the internal loudspeakers with
1,0 W	red wire to left E2, resp. blue wire to right E2
4,0 W	red wire to left E3, resp. blue wire to right E3
16,0 W	red wire to left E4, resp. blue wire to right E4
28,0 W	red wire to left E5, resp. blue wire to right E5
60,0 W	red wire to left E6, resp. blue wire to right E6
124,0 W	red wire to left E7, resp. blue wire to right E7

\*) For each channel only the half of this values is available. Values given in "Watt RMS".

Take care not to overload the loudspeakers.

**Do not change the connection of the black wire or the grey wire. They should stay on either the left or right E1 taps to define the reference potential.**

See also to the "Connection diagram for output transformer".

Connection diagram for output transformer

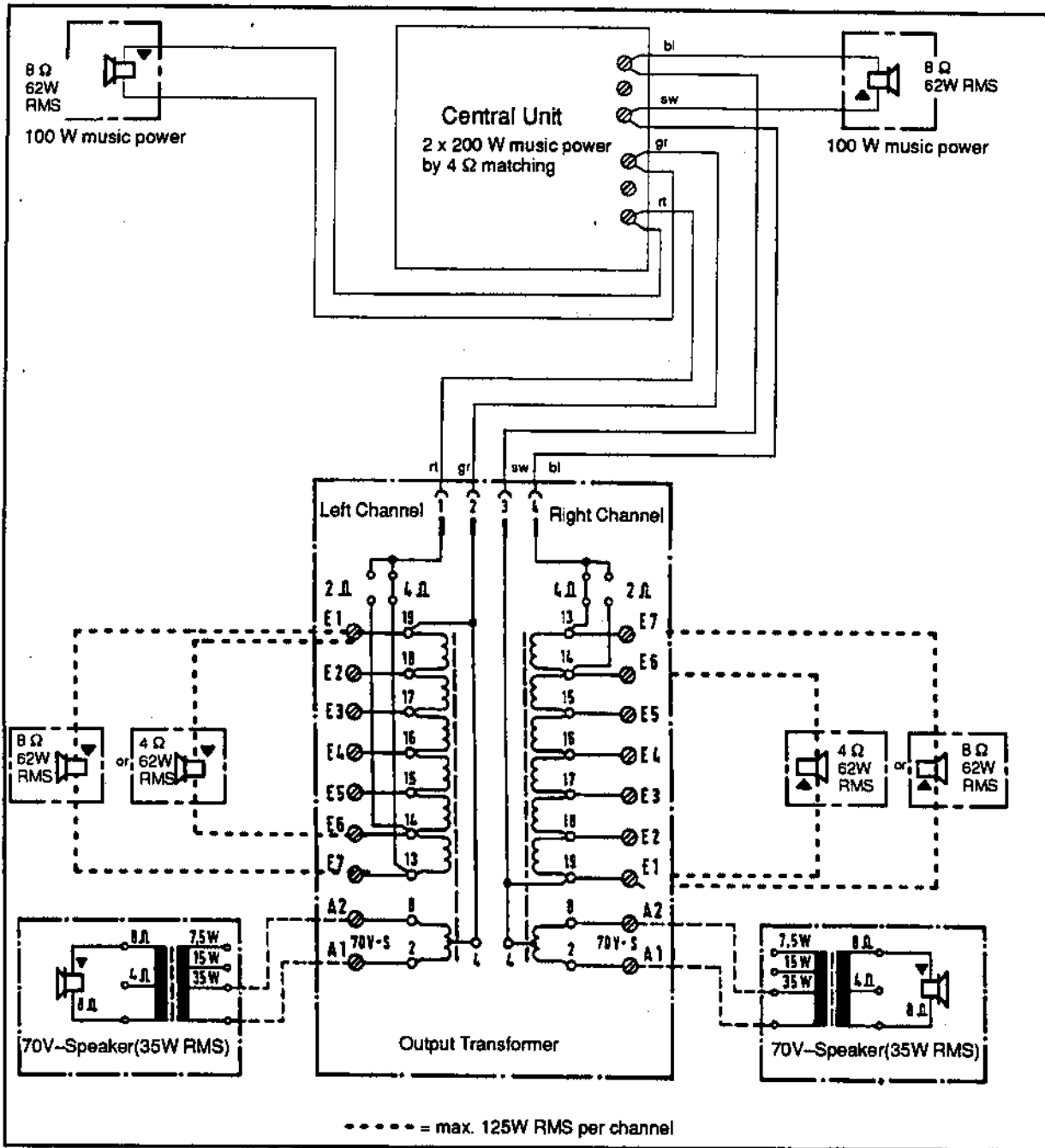

Terminal Position	Loudspeaker impedance				
	1 Ω	2 Ω	4 Ω	8 Ω	16 Ω
E1-E2	4W RMS	2W RMS	1W RMS	0,5W RMS	0,3W RMS
E1-E3	16W RMS	8W RMS	4W RMS	2W RMS	1W RMS
E1-E4	64W RMS	32W RMS	16W RMS	8W RMS	4W RMS
E1-E5	125W RMS	62W RMS	28W RMS	14W RMS	8W RMS
E1-E6	-	125W RMS	62W RMS	30W RMS	16W RMS
E1-E7	-	-	125W RMS	62W RMS	30W RMS

Connection of 70 V-loudspeakers  
max. 60 W RMS

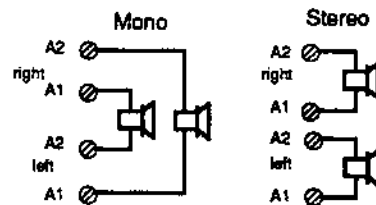

Figure 27: Connection diagram for loudspeakers and output transformer

### Checking the external loudspeaker connections (overload)

To avoid distortion of sound or destruction of equipment you should perform the following steps after changing any loudspeaker connection.

- A. Make sure that the loudspeakers are connected to the proper connectors.  
Then power on the phonograph.
- B. Set the phonograph's volume to full power (display = 31) and make a selection.
- C. While the music is playing no overload distortion or interruption should occur.  
The volume should not be decreased automatically from its maximum 31, shown on the display.  
If any distortion or interruption occurs or if the volume is decreased, the amplifier is overloaded.  
Then you have to perform step D.
- D. Perform this step only if any distortion or interruption occurs.  
Turn off the phonograph.  
Find and correct the reason for this overload, perhaps there is a short circuit on a loudspeaker  
or too many loudspeakers are connected.  
Then repeat step A-C.



**Special connection / left channel inverted**

If you want to connect already existing loudspeaker networks which work with antiphase polarity of the left channel to this phonograph you have to read this chapter.

If the phonograph is to function with a loudspeaker network with antiphase polarity or with a high impedance mono-system which has been connected between left and right channel, please proceed as follows:

Cut the soldered connection LB6 on the PCB Central Unit. By doing so, the signal of the left channel is inverted (180°, changed polarity) the signal will be antiphased then.

For **mono mode**, connect external loudspeakers between the terminal positions E2 – E7 left and E2 – E7 right of the output transformer.

Almost the double output power is measured between the channels' taps, the loudspeakers are to be connected only according to the following table and in accordance with their impedance and power.

**Power values for special mode with inverted left channel**

Terminal position	Loudspeaker			
	2Ω	4Ω	8Ω	16Ω
E2 left – E2 right	8 W RMS	4 W RMS	2 W RMS	1 W RMS
E3 left – E3 right	32 W RMS	16 W RMS	8 W RMS	4 W RMS
E4 left – E4 right	125 W RMS	64 W RMS	32 W RMS	16 W RMS
E5 left – E5 right	–	125 W RMS	64 W RMS	32 W RMS
E6 left – E6 right	–	–	125 W RMS	64 W RMS
E7 left – E7 right	–	–	–	125 W RMS

**Attention:** The total power must not exceed 2x 125 W RMS (Total 250 W RMS).

Refer to the following connection diagram:

**Connection diagram for special mode with inverted left channel**  
 (unsoldered connection LB6 on PCB Central Unit)

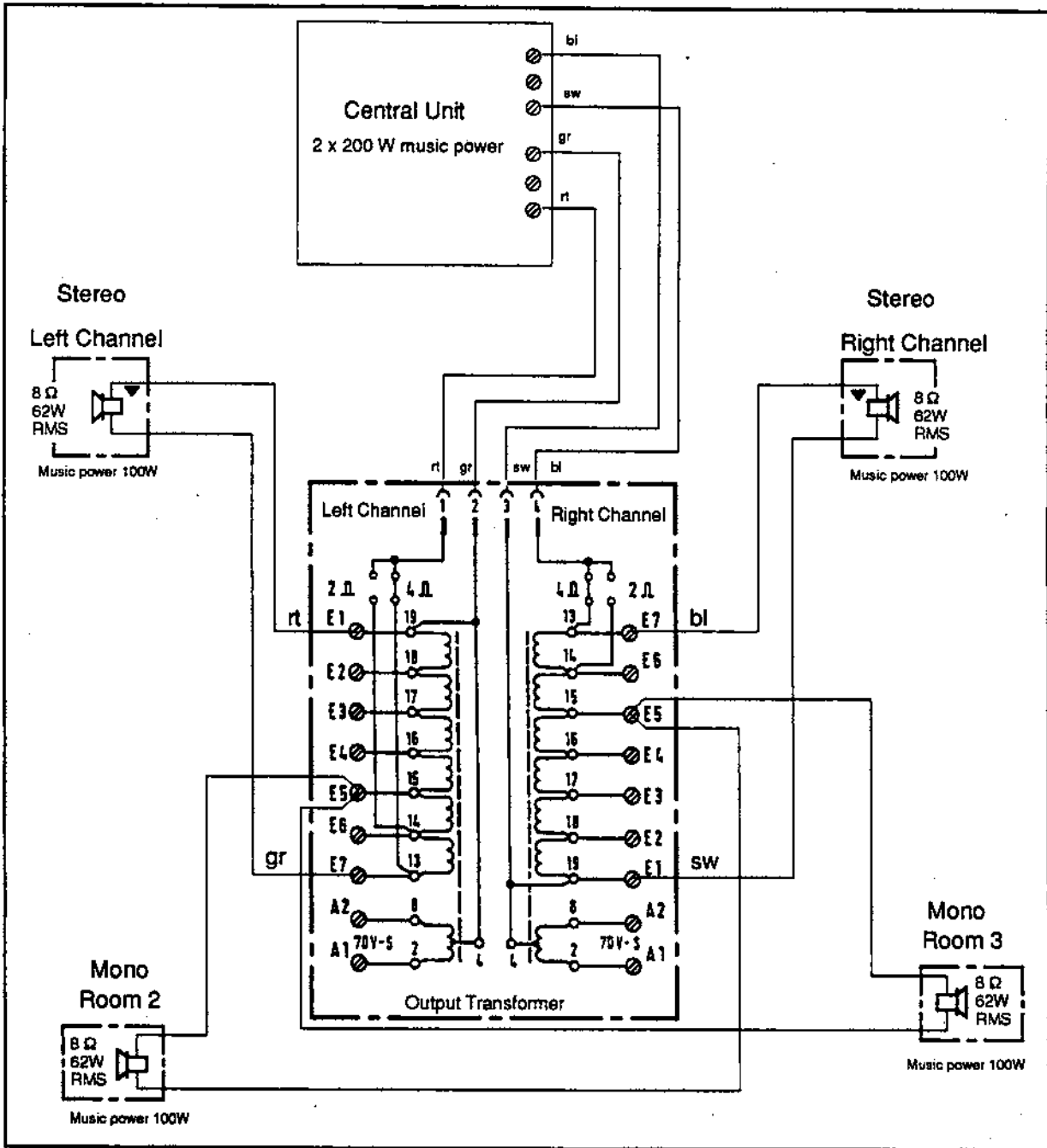
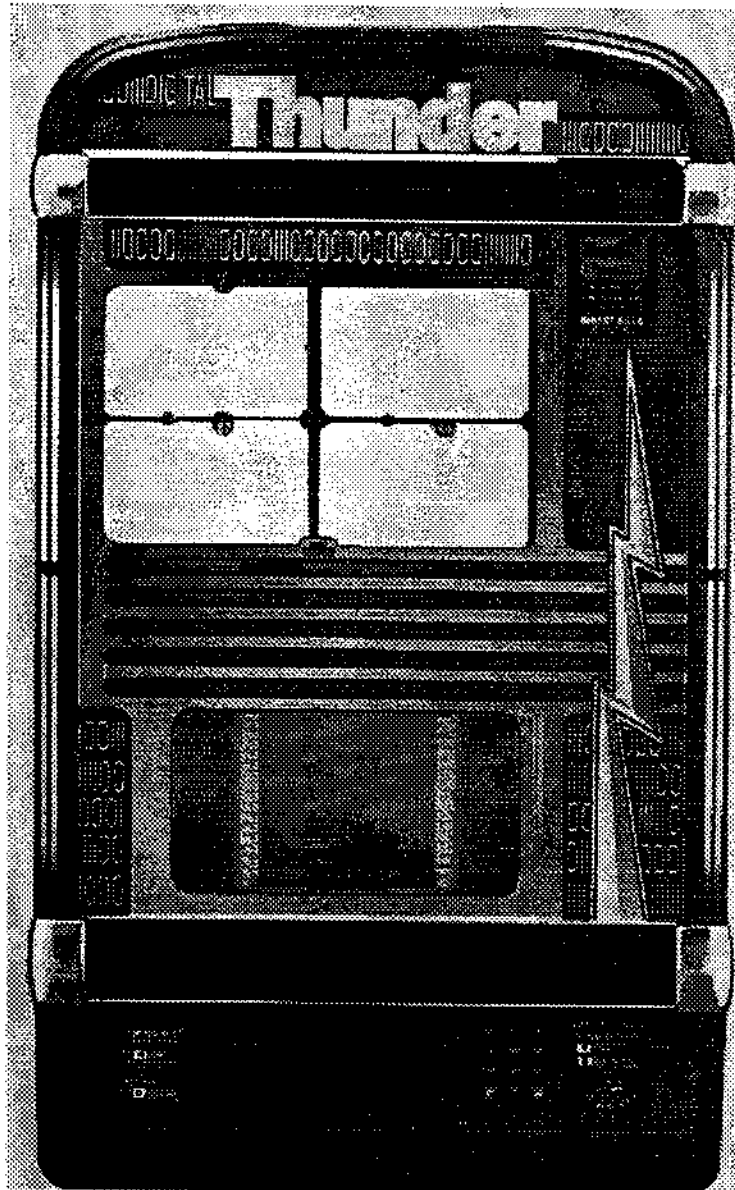

Figure 28: Connection diagram for special mode with inverted left channel

# Section 5

## DIGITAL THUNDER WALL



## Programming

## Section 5 Programming of special and individual settings

### General information, command overview

In order to program NSM phonographs in a simple yet extensive fashion, a service program has been installed with which the different settings can be altered via the keyboard of the phonograph.

In order to get into the service mode you have to perform the following steps:

- open the front door of the cabinet
- pull out the service switch (cabinet interlock switch)

By changing the display, the phonograph indicates that it is in service mode now. The display shows the following information:

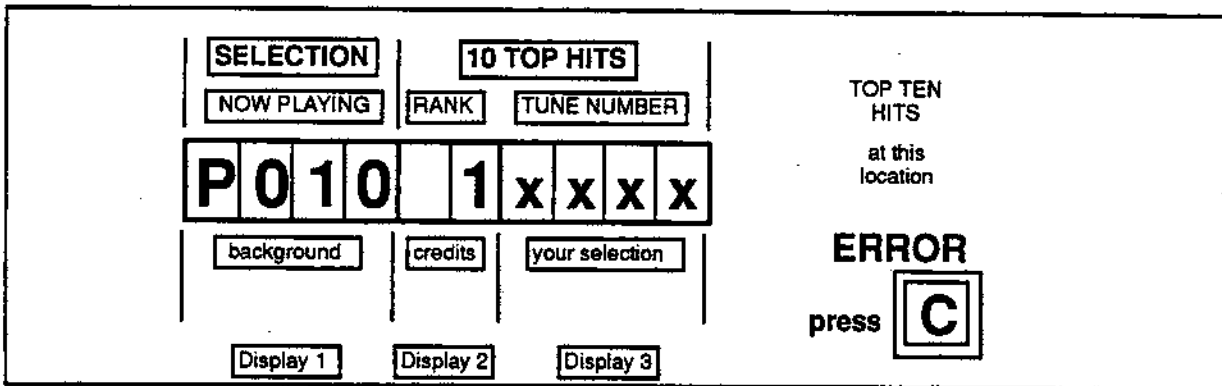
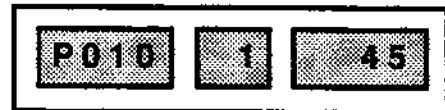

Figure 29: Display after entering the service mode

The display shows P010 and values concerning the popularity of the least played CD.

For example:



After pressing the key "C" the display is changed. To the left the letter "P" appears.



Now enter the desired command number. Zeros before the number can be left out. A command called up in error can be cancelled by pressing "C". Pressing "H" confirms the entry.

For example:

Enter: P 40 H 1 H

to program the phonograph with all default values.

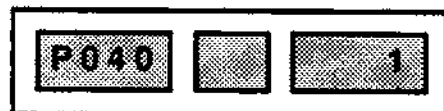

In order to find single commands more easily, all possible commands are put together in single groups.

P001	<b>Authorization:</b> Enter authorization code: *PPPP-	P040*	<b>General settings:</b> 0+H Default values for 041 to 054, 094
P002*	Change authorization code *PPPP-		1+H Default values for 041 to 054, 094 and 114, 117 ▼
	<b>Statistics:</b>	P041*	Define machine code number, maximum 4 digits "0" ✓
P010	0: Number of least played CD 1: Number of second-least played CD	P042	Selection limit for CD/track (title) maximum 100CDs, 99 tracks "0024" ✓
	2: Number of plays 3: Data about any CD	P043	Light show in stand-by, if installed "1105" ✓
P011	0: Number of the most played (best) CD 1: Number of the second-best CD	P044	Light show in operation, if installed "1000" ✓
	2: Number of plays 3: Data about any CD	P045*	Time limit for playing of tracks in minutes (0=no limit) "0" ✓
P012	0: Top-title, hit #1 1: Second-best title	P046	Sequence of playing normal selected tracks (0= fifo / 1=numerical / 2=random) "0" ✓
P013*	0: Cash amount since last evaluation 1: Accumulated Cashbox amount	P047	Maximum number of titles in a sequence from one CD (0 = no limit) "0" ✓
P014*	0: Number of coins through Chute 1 (K1) 1: Number of coins through Chute 2 (K2)	P048	Automatic advancing of title display in minutes (0= none) "0" ✓
	2: Number of coins through Chute 3 (K3) 3: Number of coins through K4 or bills into NP1	P049*	Cancels credits after power off / stand-by (x=0-no, x=1 to 240=yes) x/10 hrs. "2" ✓
	4: Number of bills into validator NP2 5: Accumulated counter for K1	P050*	Cancels selection memory after power off (no: x=0, yes: x=1 to 240) x/10 hrs. "2" ✓
	6: Accumulated counter for K2 7: Accumulated counter for K3	P051*	Maximum volume in play operation (max. 31) "31" ✓
	8: Accumulated counter for K4 or NP1 9: Accumulated counter for K5 or NP2	P052*	Maximum volume for background music (max. 31) "16" ✓
P015*1)	0: Cash amount of wall box 1: Accumulated Cashbox amount	P053	Sound system setting set volume "0505" ✓
P016*	0: Counter of played titles 1: Accumulated counter	P054	Sound system setting set treble and bass "0808" ✓
P017*	0: Counter of selected titles 1: Accumulated counter		
P018*	0: Counter of album selections 1: Accumulated counter		<b>Price settings:</b> see table "Price settings"
P019*	0: Counter of overplay titles 1: Accumulated counter	P060*	0+H Cancels previous price setting n+H Selection "n" from table (s.a.)
P020*	0: Counter for paid credits 1: Accumulated counter	P061*	Arbitrary price setting for chute 1 xx=selections, yyyy=price "xx yyyy" ✓
P021*	0: Counter for free credits 1: Accumulated counter	P062*	same for chute 2
P022*	0: Counter for background titles 1: Accumulated counter	P063*	same for chute 3
P023*	0: Counter for autoplay titles 1: Accumulated counter	P064*	same for chute 4
P024*	0: Counter for advertising tracks 1: Accumulated counter	P065*	same for chute 5
P025*	0: Counter for Happy-Hour-credits 1: Accumulated counter	P066*	Bonus listing for album setting 0: No album selection allowed "1" ✓
P026	reserved		1: No bonus
P027	reserved		2: 1 bonus for 5 titles
P028	Number of unused credits		3: 1 bonus for 4 titles
P029	Number of selections not yet played		4: 1 bonus for 3 titles
P030	Data transfer to Data Print in text mode 0: cashbox, counters, popularity, errors,...		
P031*	Data transfer to Data Print in graphic mode 0: all available data		<b>Monetary value settings:</b> see table "Monetary value settings"
	1: Cashbox	P070*	0+H Cancels previous monetary value n+H Selection "n" from table (s.a.)
	2: Counter and cashbox contents	P071*	Arbitrary monetary value setting for chute 1 zzzz=coin value (e.g. 0500=\$ 5.-) "zzzz" ✓
	3: General settings	P072*	same for chute 2
	4: Popularity of all CDs	P073*	same for chute 3
	5: Top 30 hits 6: Previous 20 error reports	P074*	same for chute 4
P032	option, not used for USA	P075*	same for chute 5
P033*	<b>Cancellation routines!</b> 0+H clear all memory entries!	P076*	Bonus credits for bill insert "0" ✓
	1+H clear hit parade! 2+H clear popularity!		
	3+H clear counters and cashbox contents! 4+H clear credits!	P077*	0: indirect revaluation 1: direct revaluation of inserted money "0" ✓
	5+H clear selection memory! 6+H clear error memory!		

P080*	<b>Programming real time clock:</b> Set time	"hhmm"	P130*	<b>Programming lock-out titles:</b> 0+H default values; cancels entries + time
P081*	Set date	"ddmmyy"	P131*	Start time for time window "Free title selection"
P082*	Set week-day (d=1 to 7)	"d"	P132*	Stop time for time window "Free title selection"
P090*	<b>Programming free credits:</b> 0+H default values; cancels entries + time		P133*	Active on week-day(s) "d" (d = 1 to 7) yes: 1+H, no: 0+H after day code display
P091*	Start time of time window "Free Credit"		P134*	Activate/deactivate lock-out: "0" 1: Title locked / 0: Title available in time window
P092*	Stop time of time window "Free Credit"		P135*	Entry of 20 titles or albums Enter: nnnn+H
P093*	Active on week-day(s) "d" (d = 1 to 7) yes: 1+H, no: 0+H after day code display		P140*	<b>Programing Happy-Hour-credits:</b> 0+H default values; no Happy-Hour
P094*	Number of free credits: 0: No free credits	"0"	P141*	Start time for time window "Happy-Hour"
	<200: No. of free credits individually used =200: Unlimited use		P142*	Stop time for time window "Happy-Hour"
	=201: Switch between no/unlimited use =202: automatically unlimited use		P143*	Active on week-day(s) "d" (d = 1 to 7) yes: 1+H, no: 0+H after day code display
P100*	<b>Programming background music:</b> 0+H default values; cancels entries + time		P144*	Calculation number (n=1 to 5) Enter: n+H (0= no Happy-Hour) "0"
P101*	Start time for time window "Background music"			
P102*	Stop time for time window "Background music"			<b>Calling up Test Programs:</b>
P103*	Active on week-day(s) "d" (d = 1 to 7) yes: 1+H, no: 0+H after day code display		P150	Read out error report memory: 0: Last reported error
P104*	Lock for background music (BGM): 0: No BGM	"0"		1: Previous error report 2: CD-Nr. at which the error occurred
	1: BGM possible in time window 2: BGM automatically in time window			3: Time of occurrence 4: Date of occurrence
P105*	Entry of 20 titles or albums Enter: nnnn+H		P151 to P159 are reserved for the service staff. See Service manual	
P106*	Patron Selection (0=free, 1=locked for guests)			
P107*	Sequence of play (0=FIFO, 1=RANDOM)	"0"		<b>Title memory:</b>
P108*	paid for BGM Enter: nn+H (0=no credit)	"0"	P160	0: Read in all CD titles, i.e. with initial equipping of all CD's
P110*	<b>Programming auto play:</b> 0+H default values; cancels entries + time		P161	Read in all titles of one newly equipped CD. Enter CD# "nn"+H
P111*	Start time for time window "Auto Play"		P162	Read the title memory, 0: Number of titles from first CD
P112*	Stop time for time window "Auto Play"			1: Number of titles from the next CD 2: Number of titles from the last CD
P113*	Active on week-day(s) "d" (d = 1 to 7) yes: 1+H, no: 0+H after day code display			3: Number of titles from any CD. Enter CD# "nn" +H
P114*	Time between two titles in minutes Enter: nn+H (0=no auto play)	"15"	P163	<b>Cancels title memory of all CD's,</b> 0+H all entries set to 1
P115*	Entry of 20 titles or albums Enter: nnnn+H			
P116*	Patron Selection (0=free, 1=locked for guests)			<b>Switching signal sources</b>
P117*	Sequence of play (0=FIFO, 1=RANDOM)	"1"	P164	This is only necessary when servicing
P120*	<b>Programming advertisement play:</b> 0+H default values; cancels entries + time			0+H Mute (no signal source) 1+H CD-player
P121*	Start time for time window "Advertisement"			2+H Tape or cassette player 3+H microphone
P122*	Stop time for time window "Advertisement"			
P123*	Active on week-day(s) "d" (d = 1 to 7) yes: 1+H, no: 0+H after day code display			
P124*	Time between two titles in minutes. Enter: nn+H (0=no adverts)	"0"		
P125*	Entry of 20 titles or albums. Enter: nnn+H			
P126*	Patron Selection (0= free, 1= locked for guests)			
P127*	Sequence of play (0=FIFO, 1=RANDOM)	"0"		

62

1)= Not yet implemented, \* = Enter authorisation code, "Value" = Factory default value

## The structure of the service program steps

The whole service program steps are divided into command groups

Table 6: Overview of Commands of the Service Program

Group	Name of Command Group	Command Numbers
1	Authorization	P001...P002
2	Statistics	P010...P026
3	Data Transfer/Cancellation	P030...P033
4	Programming General Settings	P040...P054
5	Programming Price Settings	P060...P066
6	Programming Monetary Value Settings	P070...P076
7	Programming Real Time Clock	P080...P082
8	Programming Free Credits	P090...P094
9	Programming Background Music	P100...P107
10	Programming Auto Play	P110...P117
11	Programming Advertising	P120...P127
12	Programming Lock-out of titles	P130...P135
13	Programming Happy-Hour-credits	P140...P144
14	Test Programs	P150...P157
15	Initializing CD titles into title memory	P160...P164

In the following chapter the meaning and the syntax of each command of the service program will be described in detail.

## 1. Authorization (P001 to P002)

Because the phonographs can be programmed with so much important data as well as input in cash counter and statistics, it is even more important than before that only authorized personnel may have access. For this reason access to essential data of the phonograph can be protected by using an authorization code.

### Enter Authorization Code

**P001:** In order to call up the protected commands, the authorization is started by the command P001.

*Enter: P 001 H P P P P H or P 1 H P P P P H*

The authorization code "0000" has been programmed for delivery. The memories are not protected and the operator can choose his own code by entering command P002. For security reasons the code number is not shown. In the display each number is shown as "P. When "PPPP" is shown, the secret code number is complete and after pressing "H" and leaving the programming mode, the machine is protected.

### Changing the Authorization Code

**P002:** During regular operation changing of the authorization code is only possible after previous authorization.

*Enter: P 001 H P P P P H (for authorization)*

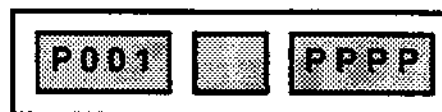

*Enter: P 002 H P P P P H (when entering new authorization code)*

**Caution:** As described beforehand, the authorization code is NEVER shown! Therefore, it is important that the code is never lost since there is no opportunity to reprogram the phonograph.

### Show version

**P003:** Enter this command to get the version of the firmware of the phonograph the CD changer MBC III or the CD player.

*Enter: P 003 H 0* shows the version of the phonograph's firmware:

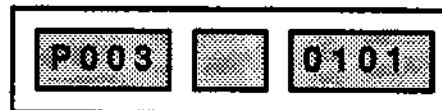

1 shows the version of the CD changer MBC III:

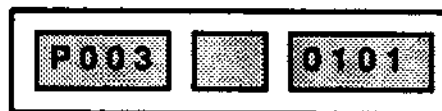

2 shows the version of the CD player:





## Statistics (P010 to P029)

Within the program group of statistics there is information regarding cash as well as statements as to how often CDs are played (popularity, hit parade).

The single commands for cash value and counters are divided into two groups. The regular information is under code "0". Cumulated values are under code "1" which have been added up since the jukebox has been operated.

Individual commands:

### Popularity

Relating to CD albums, the commands P010 and P011 are dedicated in order to determine the popularity.

- P010:**
- 0: Display of number of **least played CD**
  - 1: Display of number of the next higher CD (stepping through with "1")
  - 2: Number of plays
  - 3: Information to any CD (enter CD number)

After entering the proper code, the display shows the information such as the following:

Enter: P 010 H 0     i.e. least played CD no. 45  
                  1



Enter: P 010 H 2     i.e. 13269 plays

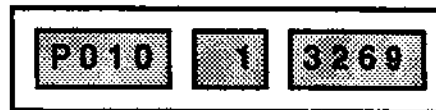

Enter: P 010 H 3 53 H     i.e. CD no. 53 in 17th place



- P011:**
- 0: Display of number of **most popular CD**
  - 1: Display of number of next higher CD (advance with "1")
  - 2: Number of plays
  - 3: Information regarding any CD (enter CD number).

After entering the proper code, the display shows the respective data.

Enter: P 011 H 0     i.e. most popular CD no. 19  
                  1



Enter: P 011 H 2     i.e. 731 plays



Enter: P 011 H 3 24 H     i.e. CD no. 24 in 2nd place



**Hit Parade**

You also can call up the top 30 titles including information of how many times a title was played.

- P012:**
- 0: Display of top title number, Hit no. 1
  - 1: Display 2nd best title (advance with key "1")
  - 2: Number of plays of the actual title

Enter: P 012 H 0

1 i.e. in 16th place:  
The third title of CD 01

2 i.e. this title was played  
169 times until now

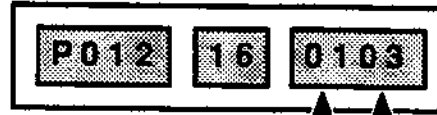

CD-no. title



**Cashbox contents**

Use the following commands to display the actual cash contents as well as diverse counter readings since the last collection. You receive statistics concerning the entire time of operation by displaying the cumulated counters.

**Cash**

The display of the cash amount is done by total numbers, read out in currency amounts. Contrary to the monetary value setting in command group P07x where the coin value multiplied by factor 100 is displayed, i.e. \$1 are entered in P07x as 0100, but are shown as 1 in P013.

Display of the cash contents is indicated by maximum 6 spaces (max. display: \$ 99 9,999 ).

- P013:**
- 0: display of cash contents since the last collection
  - 1: cumulated cash contents

Enter: P 013 H 0

1 i.e. \$34,829

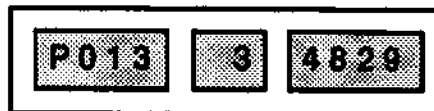

**Counter for number of coins / bills**

Besides displaying the cash levels, the counters of the individual money chutes can be called up. This makes possible an additional control of the cash contents. The five integrated counters are distributed as follows:

- Chutes 1 to 3: only coins (defined by monetary value setting P071 to P073)
- Chute 4: coins as well as bills (can be selected with P074)
- Chute 5: only bills (defined by P075)

The total of the individual counters corresponds to the total of the cashbox contents.

- P014:**
- 0: Number of coins through Chute 1 (enter P071)
  - 1: Number of coins through Chute 2 (enter P072)
  - 2: Number of coins through Chute 3 (enter P073)
  - 3: Number of coins through Chute 4 and/or bills counted in Bill Validator 1 (enter P074)
  - 4: Number of bills counted in Bill Validator 2 (enter P075)
  - 5: Cumulated counter Chute 1 (enter P071)
  - 6: Cumulated counter Chute 2 (enter P072)
  - 7: Cumulated counter Chute 3 (enter P073)
  - 8: Cumulated counter Chute 4 (enter P074)
  - 9: Cumulated counter Chute 5 (enter P075)

Enter: P 014 H 0  
           1     *i.e. 12.543 coins through*  
           2     *channel 2:*  
           ...  
           9



The respective cashbox total is derived by multiplying number of coins x monetary value of coin.

**Additional Counters**

With commands P016 to P025 diverse counters can be called up which can be used as actual counters and as cumulative ones as the commands described previously. The statistical data contained therein can be used to settle accounts.

- P016:** 0: Number of **titles played**  
1: Cumulated counter
- P017:** 0: Number of **titles chosen**  
1: Cumulated counter
- P018:** 0: Number of **albums chosen**  
1: Cumulated counter
- P019:** 0: Number of **overlay titles**  
1: Cumulated counter
- P020:** 0: Number of **credits paid**  
1: Cumulated counter
- P021:** 0: Number of **free credits**  
1: Cumulated counter
- P022:** 0: Number of **background titles**  
1: Cumulated counter
- P023:** 0: Number of **titles in auto play mode**  
1: Cumulated counter
- P024:** 0: Number of **advertising titles**  
1: Cumulated counter
- P025:** 0: Number of **Happy-Hour-credits**  
1: Cumulated counter

*i.e.:* calling up number of titles played; a total of 10273 titles were played on this phonograph.

Enter: P 016 H 1     *i.e. 10,273 titles played*  
                           *in total*

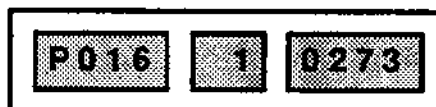

The counters P026 and P027 are not used.  
 Further interesting data are recorded in counters P028 and P029.

**P028:** Number of credits unused.  
This shows the number of paid credits available for selections of titles or albums.

**P029:** Number of chosen unplayed titles.  
This shows how many entries are remaining in the selection storage.

### Data Transfer (P030 to P031)

In this group of service program commands the data in the counters mentioned beforehand are prepared for output to a DATAprint or to evaluation devices which process the data. After calling up the command and entering the respective code, data transfer follows.

There are two ways of print-out possible:

**P030** transfers all available data in text mode.  
The data is stored within the DATAprint.  
The data can be printed out or edited on a PC i.e. with the software DATAcontact.  
The counters of the phonograph are deleted after the printout is done and the cabinet is closed.

**P031** transfers all data in graphic mode.  
The data is printed out directly after downloading.

See also the sample print outs shown in chapter "How to evaluate the statistics?"

### Display of error numbers while evaluation is performed

If an error is determined, "E0" is shown in display 3. In that case, please check the connection to the DATAprint unit.

Display of the phonograph if a transfer error occurs:



Remember to un-plug the interface cord after the print out is finished.

### DATAprint Printout in Text Mode

**P030:** 0: All data in the counters is processed and sent to DATAprint. There they are stored and printed out depending on the setting of the DATAprint.

The stored data can continue to be processed by a software tool for PCs, i.e. by DATAcontact.

Enter: P 030 H 0



### DATApri<sup>n</sup>t Printout in Graphic Mode

Contrary to the output of P030, the entire statistics as well as individual statistical areas can be printed out by P031. But the data are not stored within the DATApri<sup>n</sup>t.

- P031:**
- 0: Print all data
  - 1: Cashbox amount
  - 2: Counter with cashbox
  - 3: General settings
  - 4: Popularity of all CDs
  - 5: Hit parade of the best 30 titles
  - 6: The last 20 errors shown

Enter: P 031 H 0

1

...

6

*i.e. 4 print-out popularity:*

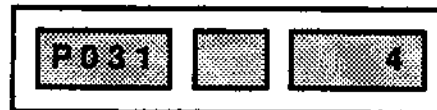

If you just would not have selected this menu item, you just push in, then pull out the service switch and you re-enter the service mode at the main menu level.

### Cancellation of counters (P033)

The P30 group contains not only the printing commands but also the cancellation commands of counters P010 to P024. Only the "regular" counters are cancelled. The cumulated counters are excluded from cancellation. The memories for credit and selection of titles as well as the error memory are cancelled.

**Note:** To avoid the cancellation of data by accident or by unauthorized persons, this function can be protected by an authorization code (enter P001).

- P033:**
- 0+H: Cancellation of all memory contents
  - 1+h: Cancels hit parade (P012)
  - 2+H: Cancels popularity (P010)
  - 3+H: Cancels counters and cashbox contents (P013-P024)
  - 4+H: Cancels credit memory
  - 5+H: Cancels selection memory
  - 6+H: Cancels error memory

**!!CAUTION!!**

**Note:** To additionally safeguard accidental cancellations, each input has to be confirmed by pressing the key "H".

Enter: P 033 H 0 H

1 H

2 H *i.e. cancel popularity:*

...

6 H



#### 4. Programming General Settings P040 to P054

In order to adjust each phonograph individually to the location requirements, certain general settings can be individually changed. Below you may find detailed values which have been set at the factory (Note: "standard values").

##### Standard values

If you generally want to reset all values to the standard values of the factory settings, you have to perform this programm step.

**P040:** 0+H: programming of standard values (P041 to P054, P077, P094)  
cancellation of values (P091 to P144), set to inactive:

P041:	0	P050	2	P077	0
P042:	0024	P051	31	P094	0
P043	1105	P052	16	P104	0
P044	1000	P053	0505	P107	0
P045	0	P054	0808	P124	0
P046	0			P127	0
P047	0			P134	0
P048	0			P144	0
P049	2				0

1+H: as above, additional programming of standard values for:

autoplay titles with defined acces to all CDs.  
P114 15  
P117 1

Enter: P 040 H 0 H  
1 H i.e. set factory standards

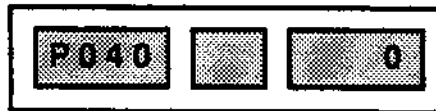

##### I.D. number of the phonograph

**P041:** Every phonograph can be programmed with its own I.D. number. DATAprint print-outs can then be easily identified if you have evaluated several machines. The I.D. number has at most 4 digits.

Enter: P 041 H nnnn H



**Maximum number of selectable CDs and tracks/titles**

**P042:** When partially equipping phonographs, unused magazine slots can be excluded. A maximum of 100 CDs (01–to 00) as well as a maximum of 99 titles can thus be selected. (Standard value: 0024).  
**Attention:** 00 = number 100

Enter: P 042 H 0024 H

i.e. allow 100 CDs with  
 24 titles each to be selected



**Note:** Please remember that with each change regarding the number of CDs, the new parameters will have to be reported to the phonograph via program step P160 or P161. Otherwise, there will be problems when playing the CD.

**Light effects in stand-by**

**P043:** A light generator can be programmed in order to attract the patrons' attention as long as no music has been selected.

**Attention:** Only useable on phonographs with a light organ installed.

Enter: P 043 H

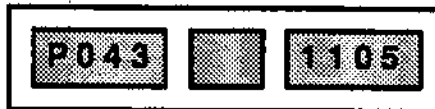

Programming the running light is done by entering a 4 digit number according to the following scheme:

A: Switch over characteristic	0= hardly 1= softly	<table border="1"> <tr><th>A</th><th>B</th><th>C</th><th>D</th></tr> <tr><td>0</td><td>0</td><td>0</td><td>1</td></tr> <tr><td>▼</td><td>▼</td><td>▼</td><td>▼</td></tr> <tr><td>1</td><td>3</td><td>1</td><td>5</td></tr> </table>	A	B	C	D	0	0	0	1	▼	▼	▼	▼	1	3	1	5	
A	B		C	D															
0	0		0	1															
▼	▼	▼	▼																
1	3	1	5																
B: Speed	0= slowly 3= fast																		
C+D: Various running lights	01 to 15																		

1105: Running light no.05, slowly with softly switching light.

**Light effects during play**

**P044:** Another light generator can be programmed here to differentiate between the two.

Enter: P 044 H

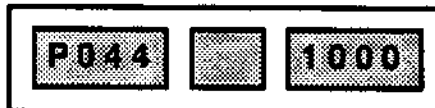

Programming the light effects is done by entering a 4 digit number according to the following scheme:

A: Mode of operation	0= steady light 1= light organ	<table border="1"> <tr><th>A</th><th>B</th><th>C</th><th>D</th></tr> <tr><td>0</td><td>0</td><td>0</td><td>0</td></tr> <tr><td>▼</td><td>▼</td><td></td><td></td></tr> <tr><td>1</td><td>3</td><td></td><td></td></tr> </table>	A	B	C	D	0	0	0	0	▼	▼			1	3			
A	B		C	D															
0	0		0	0															
▼	▼																		
1	3																		
B: Basic brightness/contrast	0= dark 3= bright																		
C+D: Various light effects	00= lightorgan 01 to 15 *)																		

\*) see P043

1000: light organ, relatively dark.

**Limit play time of one track**

**P045:** in minutes; in order to suppress long titles play time can be limited. The title playing will slowly fade when the time is up. When entering 0, there is no limit.

Enter: P 045 H nn H  
3 H: titles will slowly fade after 3 min.

P045		3
------	--	---

**Sequence of plays at normal selection**

**P046:** In order to alter the music menu, three variations can be chosen when playing :  
0 – play as selected (FIFO)  
1 – play in numerically ascending numbers  
2 – play randomly (RANDOM).

Enter: P 046 H n H  
2 H i.e. play randomly

P046		2
------	--	---

**Maximum number of titles of one CD**

**P047:** Use this program step to determine how many titles of one CD are played in sequence. Value "n" as number of titles to be played."0"means no limit.

Enter: P 047 H n H  
0 H i. e. no limit .

P047		0
------	--	---

**Automatic advancing of title display**

**P048:** Use this program step to define the automatic advance of the title display. Enter value "nn" as minutes. If minutes are entered the title display is changed accordingly in stand-by. 0 = no automatic advancing.

Enter: P 048 H nn H  
10 H i.e. advancing of title display every 10 min.

P048		10
------	--	----



**Cancel credit**

**P049:** Remaining credits are cancelled after  $n/10$  hrs. ( $n \times 6$  min.) of power off or stand-by.

Value "n" can be between 0 and 240 with commands P049 and P050.

i.e.  $n = 1$ : waiting time = 6 min.

$n = 10$ : waiting time = 1 hr.

$n = 240$ : waiting time = 24 hrs.

"0" does not cancel.

Enter: P 049 H 2 H

*i.e. cancel credit after 12 min. of  
power off/stand-by (2/10 hrs.):*

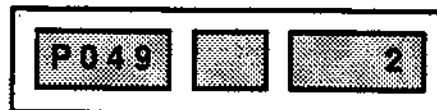

**Cancel selection memory**

**P050:** Remaining selections entered in the selection memory are cancelled after  $n/10$  hrs. ( $n \times 6$  min.) of power off.

Value "n" can be between 0 and 240 with commands P049 and P050.

i.e.  $n = 1$ : waiting time = 6 min.

$n = 10$ : waiting time = 1 hr.

$n = 240$ : waiting time = 24 hrs.

"0" does not cancel.

Enter: P 050 H 4 H

*i.e. cancel selection memory  
after 24 min. of power off:*

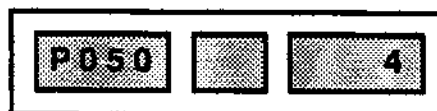

## Sound system settings

### Maximum Volume Levels

Maximum volume levels during play and background mode can be pre-set to a certain limit. The manually adjustable volume level of the phonograph cannot go beyond the set levels.

**P051:** Maximum volume during **play**; can be set between 0 (mute) and 31 (loud).

**P052:** Maximum volume for **background mode**; can be set between 0 (mute) and 31 (loud).

Enter: P 051 H 31 H  
i.e. maximum volume possible



### Set volume for play mode

**P053:** With this command the volume of the phonograph is set.

This function can be set in two ways:

In the program mode it can be set via the key pad of the phonograph or by using the remote control.

### Key pad layout for volume setting:

▲ 1 left channel louder	▲ 2 both channels louder	▲ 3 right channel louder
4	5	6
▼ 7 left channel quieter	▼ 8 both channels quieter	▼ 9 right channel quieter
C Cancel	0	H Step to the next com- mand.

Figure 30: Key pad layout for volume setting

Enter: P 053 H

Change per pressing keys  
i.e. Key "2" = louder



channel value: left, right

**Sound setting**

With command **P054** the sound setting is performed in a range from 1 to 10. Here treble and bass volume are set for both channels at the same time. The changed setting can also be immediately heard.

**Key pad layout for sound setting:**

▲ 1 more bass	▲ 2 more bass + treble	▲ 3 more treble
4 mean value	5 mean values	6 mean value
▼ 7 less bass	▼ 8 less bass + treble	▼ 9 less treble
C Cancel	0	H Step to the next com- mand.

Figure 31: Key pad layout for sound setting

Enter: **P 054 H**

Change per pressing keys  
i.e. Key "8" = less bass and treble

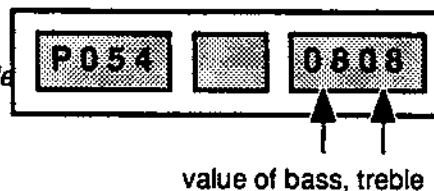

## 5. Price Settings P060 to P066

To make programming of credits easier a table for price settings via code number has been programmed for command **P060** in which actual price values have been entered. The programming of the five possible price levels can be automatized with the table.

Look for your country and enter the code number for those listed prices.

Another possibility is the individual programming of the individual price scales using commands **P061** to **P065**.

Please use 6 digits and keep the price settings in numerically increasing order (ie: **P061** lowest price, **P065** highest price)

Table 7: Price Settings

Code No.	COUNTRY	P061	P062	P063	P064	P065	Remarks
0	_____	00 0000	00 0000	00 0000	00 0000	00 0000	no coin conversion in this setting
1	Germany	01 0100	01 0100	03 0200	03 0200	03 0200	1 play = 1,-DM
2	Belgium	02 2000	02 2000	02 2000	06 5000	06 5000	
3	Netherlands	02 0100	02 0100	02 0100	06 0250	06 0250	2 different settings
4	France	02 0500	02 0500	10 1000	10 1000	10 1000	
5	Switzerland	02 0100	02 0100	05 0200	05 0200	14 0500	
6	Austria	01 0500	01 0500	03 1000	03 1000	07 2000	
7	Italy	01 0400	01 0400	01 0400	03 1000	03 1000	
8	Spain	01 0050	01 0050	02 0100	02 0100	05 0200	
9	Greece	01 2000	01 2000	01 2000	02 5000	02 5000	
10	Yugoslavia	01 0200	01 0200	01 0200	03 0500	03 0500	
11	Denmark	01 0300	01 0300	02 0500	05 1000	12 2000	4 different settings
12	Norway	01 0300	01 0300	02 0500	02 0500	04 1000	
13	Finland/Sweden	01 0300	01 0300	01 0300	02 0500	02 0500	
14	Hungary	01 2000	01 2000	01 2000	01 2000	01 2000	
15	Ireland	01 0010	01 0010	03 0020	03 0020	10 0050	
16	Great Britain	01 0030	01 0030	02 0050	02 0050	05 0100	
17	USA (1) / Canada	01 0050	01 0050	01 0050	03 0100	03 0100	Dollarbill on chan.5 (P065)
18	USA (2)	01 0050	01 0050	03 0100	03 0100	18 0500	
19	Africa	01 0020	01 0020	03 0050	03 0050	07 0100	
20	Australia	01 0100	01 0100	01 0100	03 0200	03 0200	
21	Netherl. Antillen	01 0400	01 0400	01 0400	01 0400	01 0400	
22	New Zealand	01 0050	01 0050	01 0050	01 0050	01 0050	

**Programming the price settings by standard values**

**P060:** In order to program the phonograph with the standard values of the table, the respective code number is entered after command P060 and confirmed with "H". The setting selected (*n* = code no. of the table) is automatically matched to the respective price scales.

Enter: P 060 H *n* H  
 18 H i.e. price setting: USA

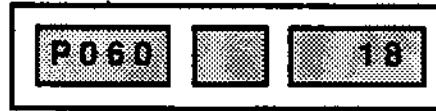

**Programming the price settings with custom settings**

**P061 to P065:** The stakes for the individual price scales can also be separately defined. With commands P061 to P065 the respective stake can be programmed. You just have to observe the order of entering the values: P061 is programmed with the lowest and P065 is programmed with the highest price setting. Unused steps may be programmed with zero or with the preceding value (examples see table)

Example of individual price setting: 12 titles for \$ 5,- (price scale 3).

Enter: P 065 H 120500 H



**Programming an album bonus**

The setting of bonus credits for album selection is done with command P066 in the service program. The following settings are permitted:

- P066:**
- 0: no album selection possible
  - 1: no bonus (default setting), this means credit for each track on the album.
  - 2: 1 bonus for every 5th track,
  - 3: 1 bonus for every 4th track,
  - 4: 1 bonus for every 3rd track.

Setting is confirmed by pressing "H".

Enter: P 066 H 0 H  
 1 i.e. no bonus  
 ...  
 4

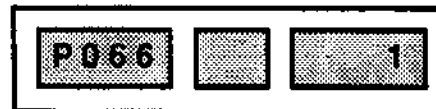

## 6. Monetary Value Setting P070 to P077

As with the price setting, the identification of the different coins as related to values processed by the phonograph can be done automatically with the pre-defined basic values. Table 8 "Monetary Value Settings" shows which setting can be programmed as basic value.

**P070:** The standard values of the table are selected with command P070 "n" + "H"  
(n = code no. from table).

Enter: P 070 H n H  
10 H i.e. USA



"n" is the code number for the setting according to table 8. To avoid erroneous entries, each entry has to be confirmed by "H". This is very important since entry of Code Number "0" cancels the current monetary value setting and no currency acceptance is possible.

### Individual monetary values

**P071 to P075:** The monetary value settings for different coin values of each chute can be individually identified. This is easily done by inserting one or more coins after command P070 has been called up. According to the coin value the program changes to the proper chute command P071 to P075. On display 1 the monetary value of each coin is displayed. This can be changed as needed. Unused chutes have to be programmed with monetary value 0.

Entries occur in the smallest counting unit of each currency that makes sense, for example USA: with \$1 ⇒ 0100. Normally the standard setting is sufficient.

### Bonus Credits

**P076:** With this command another bonus (value n = 0 to 4) is defined: the bonus for paying with bills instead of coins.

Enter: P 076 H nn H  
3 H i.e. 3 bonus credits

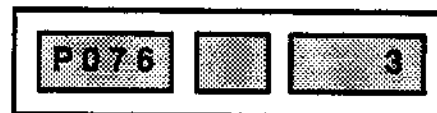

When accepting a bill in chute 5, this bonus is added to the regular credits.

### Indirect / direct money to credit revaluation

Use this command to differ between the how and when of the revaluation of inserted coins.

### P077:

- "0" + "H" Indirect revaluation: inserted coins are stored. At an appointed coins value the credit is defined from the highest possible price setting, including a possible bonus.
- "1" + "H" Direct revaluation: inserted coins are revaluated directly after insertion.  
Then no bonus is possible with multiple insertion of coins.

Enter: P 077 H n H  
0 H i.e. indirect revaluation

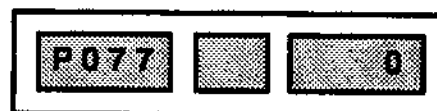

Table 8: Monetary Value Settings

Table No.	COUNTRY	channel 1(P071)	channel 2(P072)	channel 3(P073)	channel 4(P074)	channel 5(P075)	Remarks, example for 1 chan.
0		0	0	0	0	0	no coin conversion
	<b>mechanical coin acceptor</b>						
1	Germany, Switzerland, Venezuela	100	500	200	0	0	100 = 1,-DM 100 = 1 sfr 100 = 1,-Bol
2	Belgium	0	2000	500	0	0	2000 = 20 Bfr
3	Netherlands	25	250	100	0	0	250 = 2,5 hfl
4	Denmark, France	100	500	1000	0	0	100 = 1 dkr
5	Austria	500	2000	1000	0	0	500 = 5 OS
6	Italy	200	100	500	0	0	200 = 200 L
7	Spain	0	25	100	0	0	25 = 25 Pst
8	Finland, Norway, Yugoslavia	0	500	100	0	0	500 = 5 mK 500 = 5 Kr 500 = 5 Din
9	Great Britain, Ireland	20	50	10	0	0	20 = 20 p
10	USA	10	50	25	0	100	10 = 10 c, 100 = 1 \$
11	Canada	0	25	0	0	100	25 = 25 c, 100 = 1 \$
12	Union of South-Africa	20	100	50	0	0	20 = 20 c, 100 = 1 R
13	Australia	100	50	20	0	0	100 = 1 \$
14	Netherl. Antillen	0	100	25	0	0	100 = 1 NAF
	<b>electronic coin acceptor</b>						
15	Germany, Switzerland, Italy	500	100	0	200	0	500 = 5,-DM 500 = 5sfr 500 = 500 L
16	Belgium	5000	500	0	2000	0	100 = 1 Bfr
17	Netherlands	25	250	500	100	0	25 = 25 c, 500 = 5 hfl
18	France	1000	200	100	500	0	1000 = 10 F
19	Denmark, Austria	2000	500	100	1000	0	2000 = 20 dkr 2000 = 20 OS
20	Spain	200	50	25	100	0	200 = 200 Pst
21	Greece	0	50	20	0	0	50 = 0,5 Dr
22	Norway	1000	100	0	500	0	1000 = 10 Kr
23	Finland	0	500	100	0	0	200 = 200 L
24	Sweden	500	100	0	100	0	500 = 5 Kr
25	Great Britain	100	20	10	50	0	100 = 1£, 20 = 20 p
26	USA	100	25	0	50	0	100 = 1\$
27	Canada	10	100	25	0	0	10 = 10 c, 100 = 1 \$
28	Australia	0	100	20	200	0	200 = 2 \$
29	Netherl. Antillen	0	0	100	0	0	100 = 1 NAF
30	New Zealand	50	10	5	20	0	50 = 50 c

Chutes entered with "0" in this table are blocked. Be careful to block the coin pathways so that these coins will not be accepted and are rather expelled through the coin return.

## 7. Programming Real Time Clock P080 to P082

The most important update to the ES-V technology is the implementation of a real time clock. Referring to the data supplied by the clock, a number of functions have been developed that are dependent on chronological data for start and stop times. Together with the weekday programming which continues to be available, an "automatic programm" for a whole week can be developed during which all functions operate automatically.

The real time clock runs quartz-precise with a battery backed power supply if the phonograph is turned off. The clock runs on military time.

### Set time

**P080:** Use this command to set the time of the phonographs control unit. The newly set minute information starts the counter for seconds automatically at zero.





 1	2	 3
hour +1		minute +1
4	5	6
12:00	00:00	30 minutes
7	8	9
 hour -1		 minute -1
C	0	H
Cancel		Step to the next command

Figure 32: Key pad layout for command "set time"

Enter: P 080 H

change per pressing keys  
i.e. 10.45 h



### Set date

**P081:** Use this command to set the date information of the phonographs control unit. The date is shown on displays 2 and 3.

Enter: P 081 H

change per pressing keys  
i. e. May 21, 1992:

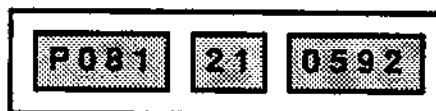



▲ 1 day +1	▲ 2 month +1	▲ 3 year +1
4	5	6
▼ 7 day -1	▼ 8 month -1	▼ 9 year -1
C Cancel	0	H Step to the next command

Figure 33: Key pad layout for command "set date"

**Set day code:** Use the command **P082** to set the day code for the week-day of the previous set date.

- Day-code
- 1 = Monday
  - 2 = Tuesday
  - 3 = Wednesday
  - 4 = Thursday
  - 5 = Friday
  - 6 = Saturday
  - 7 = Sunday

1	2	▲ 3 day code +1
4	5	6
7	8	▼ 9 day code -1
C Cancel	0	H Step to the next command

Figure 34: Key pad layout for command "set day code"

Enter: P 082 H

change per pressing keys  
i.e Thursday is 4:

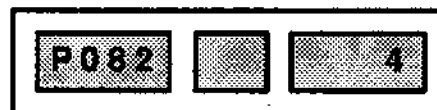

After confirming one week-day entry the phonograph switches to the next week-day.

The data supplied by the real time clock are processed by commands P090 to P135 (described as follows) for the so-called time windows. Here the entry of the time window values also occurs via the illustrated key pad layout.

Furthermore the information of time and date are used for the print-out of statistical data to the DATA-print (P030 and P031).

## 8. Programming Free Credits P090 to P094

The group of 90th commands allows the operator to give free credits (music selection without coin insert) at specified times.

Amount of free credits are set in the program as well as the time periods.

All times are based on a 24-hour clock (ie: afternoon times are from 13:00 to 23:00)

**P090:** In P090 a standard setting cancels automatically the previous setting.

The time factor is set to zero, so there are no automatic time periods for free credits.

Enter: *P 090 H 0 H*



**P091:** To set the starting time for the time window "free credit", the key pad is used (see P080).

Enter: *P 091 H*

*Set by pressing keys  
i.e. starting time 12:34  
confirm setting with key "H".*



**P092:** Here the stop time of the time window is set (see P080).

Enter: *P 092 H*

*Set by pressing keys  
i.e. stopping time 13:45.  
confirm setting with key "H".*



**P093:** Here the day is chosen on which the determined time window is to become active.

On the center display the days (according to the programs of P082) are shown through numbers 1 to 7. Each weekday can be activated individually. "1" means active on that day, "0" means non-active. The inputs must be confirmed by pressing "H".

To simplify the entries it is defined that the whole week is active with "0" or "1" (for all days).

Enter: P 093 H

0 or 1 H

Set per pressing keys

i.e. Monday is inactive

confirm setting with key "H".



After confirming one day's entry the software steps to the following day.

**P094:** Entering the number of free credits.

Different settings are possible:

- 0: No free credits possible (factory setting).
- <200: Limited free credit. Free credits can be used one at a time subtracts from total input.
- =200: Unlimited free credit while time window is active.
- =201: Switching between no free credits and unlimited free credits while time window is active. Switching via remote control.
- =202: Free play automatically while time window is active. If non-active switching is done via remote control.

Enter: P 094 H 200 H

i.e. no free credit:

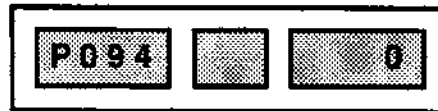

## 9. Programming Background Music P100 to P107

The phonograph operator can call up the background mode. This operational mode remains even after a power failure. If money is inserted into the machine and a title selected, the background music is faded out and the paid for selection is started.

**P100:** If the command P100 is called up and "0" is entered and confirmed with "H", the default setting is activated because all settings of group P10x will be set to 0.

Enter: P 100 H 0 H



With command **P101** the starting time and with command **P102** the stopping time are set for the time window of background music. Key pad layout see P080.

**P103:** With command P103 the week-days are set when background music should be played. Key pad layout see P082.

Enter: P 103 H 0 or 1 H

Set per pressing keys  
i.e. Wednesday inactive:  
confirm settings with key "H"



With confirming one entry the software steps to the following week-day.

**P104:** With command P104 the mode of operation is set. Three types are possible:

- P104 "0" no background music. This value is the factory setting.
- P104 "1" allows starting and stopping background music by pressing background key on machine or on remote control.
- P104 "2" automatically plays background music at defined times of the time window.

Enter: P 104 H n H

2 H i.e. automatically  
within the time window



**P105:** What is played as background music is also determined by the operator. With command P105, followed by 20 four-digit entries, 20 titles or albums can be determined. With no entry in P105 all CDs (defined by P042 to be selectable) are played.

Enter: P 105 H nnnn H  
*i.e. first entry: CD #17 title 3*



**P106:** A new function is the "Patron Selection". With command P106 the operator determines whether the selected titles for background music can also be chosen by other customers.

P106 "0" titles and albums free for selection  
 P106 "1" titles or albums are locked.

Enter: P 106 H n H  
*0 H i.e. titles are not locked:*

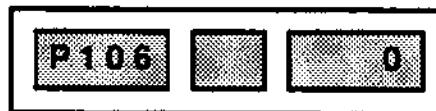

**P107:** The titles selected in P105 are played in the sequence selected in P107.

P107 "0" sequence of play in order of entry (FIFO), factory setting  
 P107 "1" random play (RANDOM).

Enter: P 107 H n H  
*0 H i.e. FIFO playing:*



**P108:** With this step background music can be set up in such a way that it has to be paid for. In this case, every time BGM is turned on "n" credits are subtracted, independent of the number of titles to be played. When n=0 no credits are subtracted.

P108 "0" Background music as in the past, without credit.  
 P108 "n" Background music deducts "n" credits (n=1 to 99).

Enter: P 108 H n H  
*2 H i.e. two credits are deducted:*



## 10. Programming Auto Play P110 to P117

The phonograph can be programmed to automatically play a title once in a while to attract the public during stand-by, when no selections are being made. The factory setting (P040=1) makes it possible that any title is played every 15 minutes (P114=15, P117=1).

**P110:** The standard setting is "no auto play" since with command P110 "0" + "H" all entries in group P11x are set to zero.

Enter: P 110H 0 H

*i.e. set standard values:*

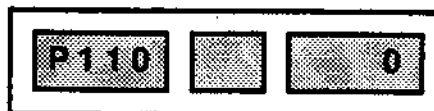

With command **P111** the starting time and with command **P112** the stopping time are set for the time window of auto play. Key pad layout see P080.

**P113:** With command P113 the days are set for auto play. Key pad layout see P082.

Enter: P 113 H 0 or 1 H

*Set per pressing keys  
i.e. Wednesday inactive:  
confirm settings with key "H"*



After confirming one day's entry the software steps to the following day.

**P114:** With command P114 the mode of operation is set. Three types are possible:

P114 "0" + "H"                   no auto play  
P114 "nn" + "H"               time between two titles (nn = max. 99 minutes)

Enter: P 114 H nn H

*30 H i.e. all 30 minutes play an  
animation title*



**P115:** With command P115 followed by 20 four-digit entries (value nnnn), 20 titles or albums can be defined. Without entry in P105 all CDs (defined by P042 to be selectable) are played.

Enter: P 115 H nnnn H

*i.e. first entry: CD # 97 all titles*

P 115		9700
-------	--	------

**P116:** also defines a "Patron Selection" (see P106) which defines if a title is locked or not

P116 "0" titles and albums are free for selection

P116 "1" titles and albums are locked.

Enter: P 116 H n H

*0 H i.e. titles are not locked:*

P 116		0
-------	--	---

**P117:** defines the sequence of play for the titles or albums chosen under P115.

P117 "0" Play in sequence of entry (FIFO)

P117 "1" Play randomly (RANDOM)

Enter: P 117 H n H

*1 H i.e. play randomly:*

P 117		1
-------	--	---

## 11. Programming Advertisements P120 to P127

The broad distribution of CDs has led to advertising for various areas being recorded on CDs. Thus, you have another source of income with phonographs with ES-V technology. Standard value is again "no advertising".

**P120:** With the command P120 "0" + "H" all entries of group P12x are cancelled (set to zero) and no advertisement is played.

Enter: P 120 H 0 H  
i.e. set standard values:



With command **P121** the starting time and with **P122** the stopping time are set for the time window of advertisement play. Key pad layout see P080.

**P123:** With P123 the days are set for advertisement play. See P082 for key pad layout.

Enter: P 123 H 0 or 1 H  
Set per pressing keys  
i.e. Sunday inactive:  
confirm settings with key "H"



After confirming one day's entry the software steps to the following day.

**P124:** With P124 it is set if or if not and how much time between advertising spots should be allowed.

P124 "0" + "H" no advertisement play  
P124 "nn" + "H" time between titles (nn = max. 99 minutes).

Enter: P 124 H nn H  
30 H i.e. play a title  
every 30 minutes:

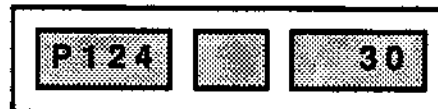



**P125:** With command P125 followed by 20 four-digit entries (value nnnn), 20 titles or albums can be defined.

Enter: P 125 H nnnn H

*i.e. first entry: CD # 90 3.title*

P 125	1	9 0 0 3
-------	---	---------

**P126:** defines "patron selection" again. See P106.

P126 "0" titles and albums are free for selection  
 P126 "1" titles and albums are locked.

Enter: P 126 H n H

0 H *i.e. titles are not locked:*

P 126		0
-------	--	---

**P127:** defines the playing sequence for advertising spots selected with P125.

P127 "0" Play in sequence of entry (FIFO)  
 P127 "1" Play randomly (RANDOM)

Enter: P 127 H n H

1 H *z.B. title in playing sequence*

P 127		1
-------	--	---

## 12. Programming Lock-Out Titles P130 to P135

At certain times it may be necessary to lock-out one or more titles from being played. Perhaps these titles should not be played by minors or are simply damaged (bad playing quality). Standard is that all titles can be played.

**P130:** With the command P130 "0" + "H" all entries of group P13x are set to zero and no CDs or titles are locked-out.

Enter: P 130 H 0 H

*i.e. set standard values*



With command **P131** the starting time and with **P132** the stopping time are set for the time window for lock-out. Key pad layout see P080.

**P133:** With P133 the day is set. See P082 for key pad layout.

Enter: P 133 H 0 or 1 H

*Set per pressing keys  
i.e. Saturday active:  
confirm settings with key "H"*

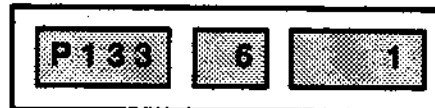

After confirming one day's entry the software steps to the following day.

**P134:** With P134 "0"+"H" the titles can be selected in the time window; with "1" they are locked-out.

Enter: P 134 H 1 H  
0 H

*i.e. all titles are  
selectable within the  
time window:*



**P135** defines a maximum of 20 titles or albums which are supposed to be locked-out. Input occurs with 4 digits for the CD number (nn\_\_) and the title (\_\_nn).

Enter: P 135 H nnnn H

i.e. 1.entry: CD #85 all titles  
etc.



**NOTE:** Take care to change entries in P135 (if necessary delete entry) to a certain CD number if you change this CD. To delete an entry you step through the list of P135 by pressing key "H" as long as you reach the right entry. Now enter "0" and confirm with "H".

Or you delete all entries by setting default values with command P130 and "0" + "H".

### 13. Programming Happy-Hour-Credits P140 to P144

For additional attraction of the audience this function is implemented.

At defined times of the week additional free credits (Happy-Hour-credits) are given, depending on the number of paid for credits.

Standard setting is that no Happy-Hour-credits are given.

**P140:** With the command P140 "0" + "H" all entries of group P14x are set to zero so that there is no happy-hour.

Enter: P 140 H 0 H

*i.e. set standard values  
No Happy-Hour:*



With command **P141** the starting time and with **P142** the stopping time are set for the time window for Happy-Hour-credits. Key pad layout see P080.

**P143:** With P143 the day is set. See P082 for key pad layout.

Enter: P 143 H 0 or 1 H

*Set per pressing keys  
i.e. Saturday active:  
confirm settings with key "H"*



After confirming one day's entry the software steps to the following day.

**P144:** Here a calculated number may be programmed. This number defines how many credits must be bought to get an additional Happy-Hour-credit.

P144 "0"+"H" no Happy-Hour

P144 "n"+"H" after "n" bought credits (n=1 to 5) 1 additional Happy-Hour-credit is given.

Enter: P 144 H n H

*3 H i.e. after 3 bought credits  
1 additional Happy-Hour-  
credit is given*

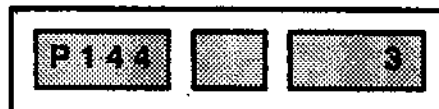

## 14. Initialization and Test Programs P150 to P164

To help the operator when loading the CD changer with new CDs, trouble-shooting or servicing, several aid functions have been incorporated from earlier phonographs. Group 15x of the test programs includes functions such as read-out of error memory, various continuous run tests as well as input and display tests. For these purposes, the group code (Fx) is shown in the middle display. Group 16x serves to initialize the CDs and their number of tracks in the title memory of the phonograph.

### Test Programs for Service Operation

#### **P150:** Read-out of Error Memory:

- 0: last registered error; see table 9 for "Error Codes" on the next page.
- 1: previous error; the phonograph records the last 20 error reports.
- 2: CD number during which the error occurred.
- 3: Time of error and
- 4: Date of occurrence

Display:



#### Continuous run tests

With commands P151 to P153 various tests in continuous run mode are executed. A continuous run can only be stopped by using the cabinet switch.

#### **P151:** Plays all CDs for 16 sec. (F1):

Enter: *P 151 H 0*

Start continuous run 1:



CD / Track

number of errors

#### **P152:** Plays selected CDs for 16 sec. (F2):

During CD play another number "nnnn" can be entered (continuous run 2). With each entry "Your Selection" will light up on the display panel.

Enter: *P 152 H n n n n H*  
(enter a CD-number)

#### **P153:** Other Continuous Play Tests (F3 to F5):

Enter: *P n*

- 0: All CDs are placed on player, but are not played (continuous run 3, F3).
- 1: 6 certain CDs (CD No. 1, 25, 50, 51, 75, 00) are placed and played 16 sec. each continually (continuous run 4, F4)
- 2: Combination of twice continuous run 3 followed by 4 until cabinet switch is turned off (continuous run 5, F5).

#### **P155:** Display Test (F6):

During the display test all digits of the displays and all control lamps are turned on and off. Pressing "H" will stop the test and continue it after pressing "H" again. The display test does not check the lamps of a light organ that might be connected. Pressing "C" stops the test.

Enter: *P 155 H*

- 0: Start lamp test  
(Display 2 shows briefly F6)



Table 9: Error Displays

Displays			Possible Causes	Corrections
1	2	3		
Er	01		EPROM contents (CONTROL-UNIT) disturbed.	Change EPROM (IC2).
Er	10		RAM (CONTROL-UNIT) defective.	Change RAM (IC 3). After that reprogram all program steps.
Er	11		RAM contents (CONTROL-UNIT) short-term disturbance.	No correction necessary; program is reinitialized. Change RAM IC 3 if frequently occurring.
Er	12		RAM battery is empty.	Change RAM (IC 3). After that reprogram all program steps.
Er	20		Verification errors in program (CONTROL UNIT).	No correction necessary; program is reinitialized. Change CPU IC 1 if frequently occurring.
Pxxx	Er	30	Memory contents (CONTROL UNIT) lost or missing.	No correction necessary; program step Pxxx (in display 1) is automatically reprogrammed.
Pxxx	Er	31	Memory contents (CONTROL UNIT) incorrect.	Program step Pxxx shown in display 1 must be reprogrammed.
Pxxx	Er	40	Wrong price setting.	Check price setting and reprogram if necessary.
Er	50		Coin mechanism defective. Too much credit. Coin channel failure.	Check coin mechanism.
Er	6x		Error at CD player.	See Er 60 – Er 63.
Er	60		Connection to the CD-player interrupted. No supply voltage present for decoder board or CD player.	Check connection cables to the decoder board, check fuses.
Er	61		No CD recognized by CD player. No CD in CD tray, CD defective. Player defective.	Check CD and exchange if needed. Exchange CD player. Exchange decoder board.
1-20-97	Er	62	Specified track on the CD not found.	Check the CD.
Er	63		Malfunction while playing a CD.	Check the CD player with equipped CD for easy running.
Er	64		Connection to CD changer	Check connection cables and control cable to CD changer. Check fuses.
Er	70		Malfunction of operating control.	No correction necessary.
Er	71		Malfunction of CD changer.	If error display does not disappear after 2 sec., error cannot be automatically corrected. No CD will be played until cabinet switch or "power on" is activated.
Er	71		Error during grip from magazine.	Load CD-tray to magazine. Check alignment from magazine to pickup assy and adjust if necessary. Check function of light barriers sGrL and sGR.
Er	72		Error during replacing CD in magazine. Malfunction of grip lever.	Check alignment of magazine to pickup assy and adjust if needed. Check function of grip. Check function of light barriers sGrL and sGR.
Er	73		Malfunction during lift drive. Playing of CD not possible.	Check lift for jamming. Check function and correct adjustment of light barrier Encoder (drive wheel).
Er	74		End position of lift not o.k.. Playing of CD not possible.	Check function and adjustment of light barrier slift.
Er	80		Short circuit on wallbox signal wire.	Check wallbox connection.
Er	81		Malfunction of the audio processor (CB CENTRALEINHEIT).	Change IC 1 = TDA 4390 if frequently occurring.
Er	90		Title display, three jams in sequence, not functional anymore.	
Er	91		Jam in title display while left movement.	Un-jam X
Er	92		Jam in title display while right movement.	X
Er	93		Jam in title display, stack left.	
Er	94		Jam in title display, stack right.	

### **Additional test programs for the service operator**

#### **Test of the Control Unit (Input Test "F7")**

**P156:** The input test checks all input ports and shows the results in a matrix on display 3. The test can be stopped by pressing "C". This function is only allowed to be carried out by authorized service staff, therefore you can find more information only in the Service Manual.

#### **Checking the adjustment of the CD changer**

##### **P157: Manual control of CD changer via key pad (F8):**

In this test program the CD changer is controlled manually via the keyboard. Several functions are executed by pressing the corresponding key depending on whether a CD is on the laser player or not. This test serves to check the light barrier in the various positions.

#### **Adjusting of grip-reference**

**P158:** This function allows the service operator to set in the adjustment of the grips to the CD-trays via display and keyboard of the phonograph. You can find more information only in the Service Manual, because this function is only allowed to be carried out by authorized service staff.

#### **Adjusting of the lift-reference**

**P159:** This function allows the service operator to set in the adjustment of the lift to the CD-trays via display and keyboard of the phonograph. You can find more information only in the Service Manual, because this function is only allowed to be carried out by authorized service staff.

## 15. Recording titles into title memory

### **P160:** Recording title quantities of all CDs

After calling up this command, the phonograph searches through all CD trays in both magazines up to the number of CDs defined in P042. During the search it reads the number of titles recorded on each CD and stores this information into the title memory. This command is to be used after initial loading of CD's or if several CDs are exchanged.

The number of titles on each CD is registered in the title memory. Simultaneously, the CD number and amount of tracks are displayed.

Enter: P 160 H 0

i.e. result: CD 01 has 24 titles



### **P161:** Initializing of one CD

After calling up this command and entering the number of the newly installed CD, its number of titles is registered in the title memory. The number of titles from each CD is also read with every normal play. This function serves as single entry cancellation, if a not initialized CD is selected.

Enter: P 161 H nn H

67 H i.e. = CD #67:



### **P162:** Read-out all title memories

After calling up this command and entering the code number, the corresponding CD's data will be displayed.

- 0: Number of titles from CD #01
- 1: Switch to the next CD #
- 2: Return to the previous CD #
- 3: Title number of any CD



With P162,3 the two-digit CD number must be entered and confirmed with "H".

### **P163:** Erasing entry in title memory

All entries in the title memory are set to 1. So all CD titles are cleared, but the phonograph may access any CD tray. If new CDs are loaded and the command P160 is used you may be sure that all new titles are stored in the title memory.

Enter: P 163 H 0 H



After removing a CD you also have to remove the corresponding CD cover in the display unit.



## 15.1 Switching signal sources for testing the audio amplifier

### P164:

For test purposes different signal input ports for the 3 intended signal sources can be switched individually. This is done with command P164 by entering different code numbers:

- 0: No signal source active, mute (amplifier turned off)
- 1: CD changer is signal source
- 2: An audio cassette player (tape recorder) is signal source.
- 3: A microphone is signal source.

This "manual" switching occurs automatically in normal play according to the signal source that is turned on.

Enter: P 164 H n H  
2 H *i.e. for tape recorder:*

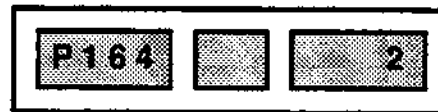

# Section 6

## DIGITAL THUNDER WALL

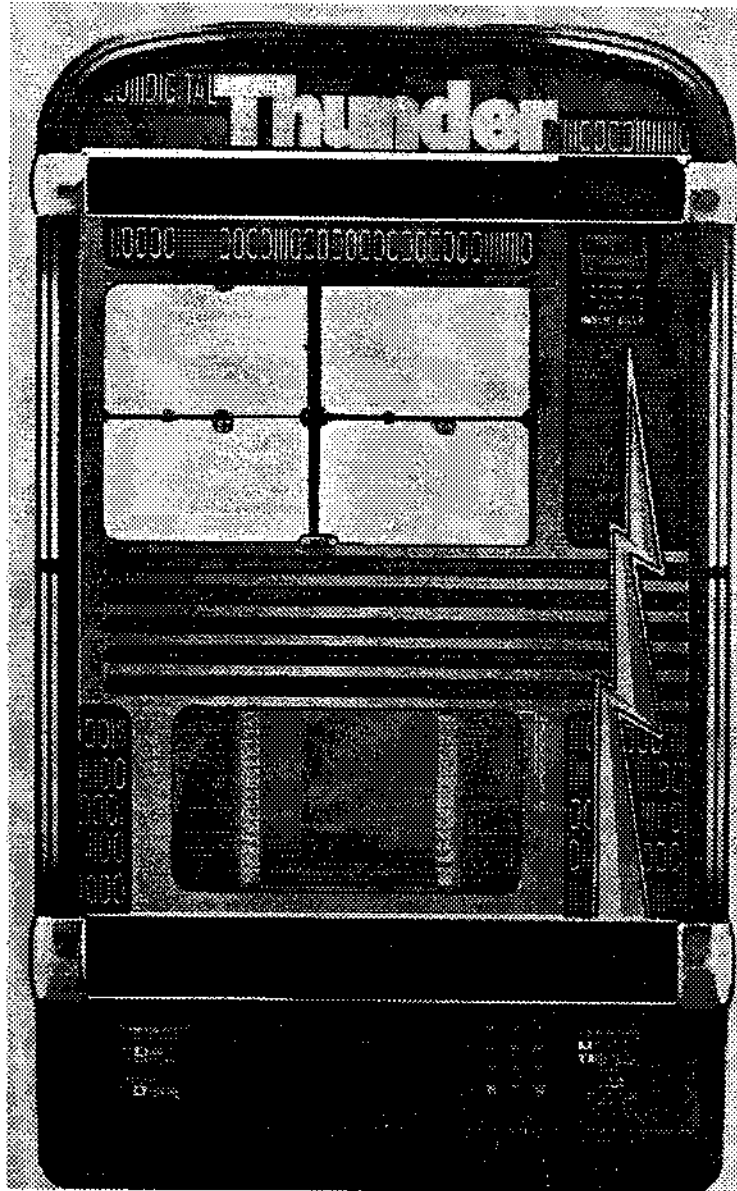

## Maintenance

## 6. Section Maintenance

### Cleaning the housing of the phonograph

Clean the housing using a soft and humid leather rag.

**DON'T USE ANY CHEMICALS FOR CLEANING THE PHONOGRAPH !**

### Cleaning of the glass and plastic panes

Clean the glass panes of the phonograph using a solvent-free window cleaner.

**Attention!** Clean plastic panes only using a humid leather rag.

**Don't use any chemicals for cleaning the phonograph! Parts of the phonograph could be damaged.**

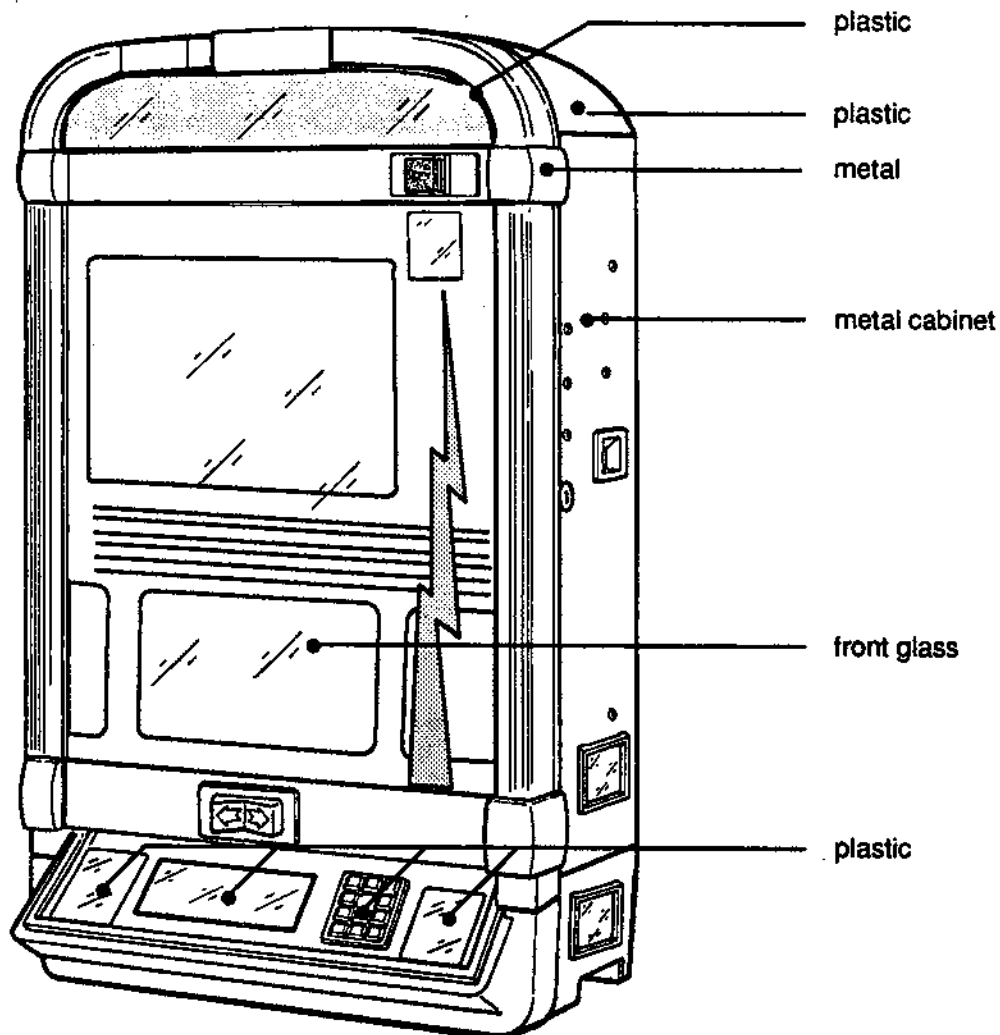

Figure 35: Cleaning of the phonograph

## Cleaning the inside of the phonograph

Besides the outside cleaning of the phonograph, the inside has to be cleaned according to the degree of pollution once or twice a year with the help of a vacuum cleaner.

## Lubrication chart for the title display

Only the title indication of the phonograph has to be cleaned and lubricated (greased) regularly. Proceed as follows.

1. Take all title holders out of the title display.
2. Clean front and back of the drivers (fig. 36/I) and the inner edges (fig. 36/II, III) of the holder brackets I and II in the lower deck. Remove the old grease. Then slightly grease with Molykote D.
3. Clean the different opto-couplers (fig. 36/IV) with a small pencil from dust and attrition.
4. Before setting in again the title holders clean them with a soft and fuzzy-free cloth. The upper and lower inner edges should be slightly greased with vaseline.

**Note:** During insertion special care has to be taken that the first holder has to be placed into the last slot of the worm drive of the title display. The next holder has to be inserted into the next slot directly in front of the previous. If you have accidentally skipped one slot, all following title holders have to be removed again.

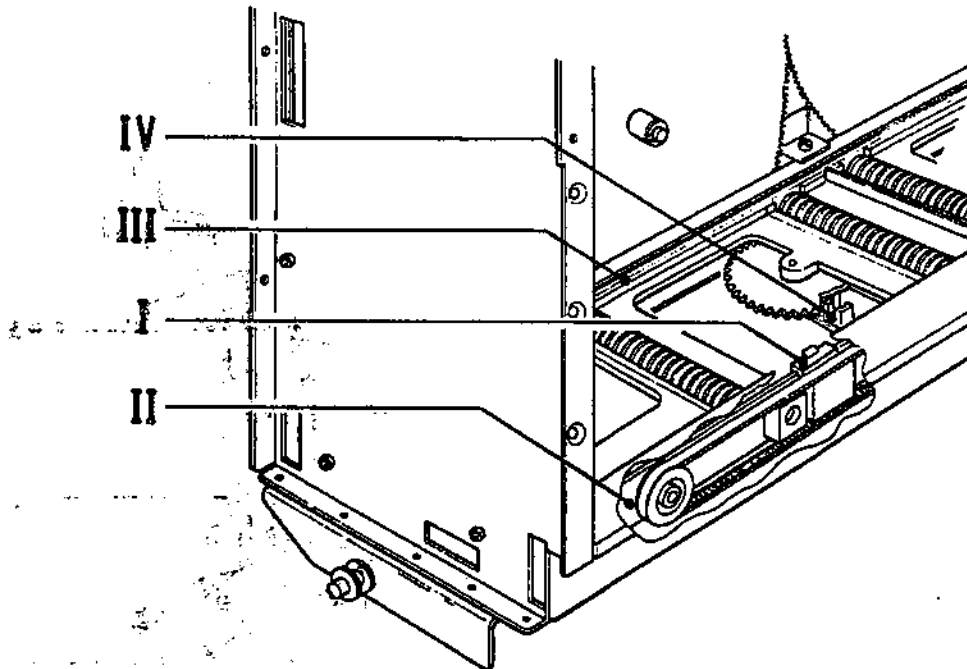

Figure 36: Lubrication chart of the title display

## Replacing fluorescent lamps, starter sets, and ballast of the front frame

### Replacing the fluorescent lamps 4W within the front frame

- Pull out the mains plug and open the phonograph.
- Open the lock of the relating side on the top right or left and remove the plastic cover.
- Remove the coloured lamp cover from the defective fluorescent lamp and mount it over the new one.
- Set in the new fluorescent lamp and rebuild the front frame.

### Replacing the vertically positioned fluorescent lamps 13 W within the front frame

- Pull out the mains plug and open the phonograph.
- Eventually separate leads from the coupling (2).
- Release the wiring in the binding post (1), pull off ground wires.
- Loosen the screw (7) and remove adapter (6).
- Loosen flat head screw (3). Strip the lamp holder (5) with the lamp down to the bottom (4).
- Remove the coloured lamp cover from the defective fluorescent lamp and mount it over the new one.
- Set in the new lamp and rebuild the front frame.

### Replacing defective starter

- Pull out the mains plug and open the phonograph.
- Replace the starter set and restart device.

### Lamp ballast

- Pull out the mains plug and open phonograph.
- Loosen cable connectors at the choke and at the coupling of the front frame (2).
- Remove the four screws and take off the cap.
- Exchange lamp ballast and rebuild phonograph.
- Restart device.

