

# Technical manual

for the NSM phonograph

## *Gemfire*

Part-No.: 179 570

### Conventions to this manual:

**Note:** *Following information given as "Note:" will lead you to easy use of features of the phonograph*

**Attention:** disregarding the safety messages following "Attention:" can cause material damage (damage of parts).

**Danger:** disregarding safety messages following "Danger:" can cause personal damage.

## Please read the following warnings

**Intended use:** This NSM phonograph is assigned to play CD's after insertion of a necessary amount of money.

Any other usage apart from this is defined as not intended.

The technology of the NSM phonograph is state of the art and is very reliable when operating.

Improper use of the phonograph may cause residual risks if it is serviced by non-authorized personnel.

**Attention:** Servicing is allowed by qualified service personnel only. To avoid electric shock do not perform any servicing or repairs unless you are qualified to do so.

**Danger:**  Before opening any parts or covers marked with this lightning sign or working on the components connected to the main voltage, example power switch, main transformer, fluorescent lamps and lamps holder, you must unplug the power cord!

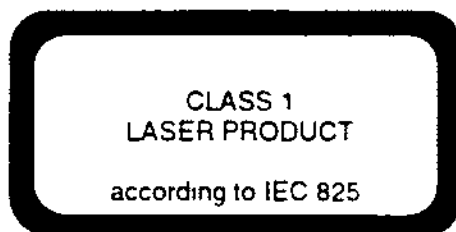

The CD-player with a laser scanning system used in this phonograph is a class I product (no risk, harmless laser system). The respective label is printed on the identification plate of the changer.

**Version 10/31/98 – 1 (V0107)**

The information and illustrations contained in these technical documents are up to date at the time of publication

**Subject to technical modification without obligation to modify equipment already delivered!**

**No reprint in full or part unless approved!**

Manufactured in Germany

Copyright by NSM Aktiengesellschaft \* 55411 Bingen am Rhein \* Germany

Part number of this documentation: 179 570



## Declaration of conformity EC

corresponding to the EC guiding rules

- Electromagnetic compatibility 89/336/EEC
- Low voltage 73/23/EEC

The product

**NSM phonograph  
Gemfire**

has been developed, constructed, and manufactured  
in accordance with the above mentioned EC guiding  
rules under the sole responsibility of

**NSM Aktiengesellschaft  
Saarlandstr. 240  
55411 Bingen am Rhein**

This declaration becomes invalid following product  
modifications which are not authorized by NSM.

The following harmonized standards have been  
applied:

- EN 55 022 and EN 55 014; (EMC)\*
- EN 50 082; IEC 801-2 to IEC 801-4 (EMI)\*

Bingen am Rhein, 10/31/98

\* Explanation of the abbreviations:

EMC = Electro-magnetic compatibility

EMI = Electro-magnetic immunity from interference

### **FCC–Declaration (USA market only)**

**Note:** This equipment has been tested and found to comply with the limits for a Class B digital device, pursuant to Part 15 of the FCC Rules. These limits are designed to provide reasonable protection against harmful interference in a residential installation. This equipment generates, uses, and can radiate radio frequency energy and, if not installed and used in accordance with the instructions, may cause harmful interference to radio communications. However, there is no guarantee that interference will not occur in a particular installation. If this equipment does cause harmful interference to radio or television reception, which can be determined by turning the equipment off and on, the user is encouraged to try to correct the interference by one or more of the following measures:

- Reorient or relocate the receiving antenna
- Increase the separation between the equipment and receiver
- Connect the equipment into an outlet on a circuit different that to which the receiver is connected from
- Consult the dealer or an experienced radio/TV technician for help

### **Instructions for placing the phonograph the license certificate (USA market only)**

The license certificate has to be placed at an appropriate position within the title display unit.

You will receive the license certificate after having paid the necessary fee to the Jukebox License Office.

Please find the registration documents within the phonograph.

<b>1. Section</b> .....	<b>1</b>
<b>1.1. Overview of components</b> .....	<b>1</b>
<b>1.2. Technical data of the phonograph</b> .....	<b>2</b>
<b>1.3. Follow the following safety instructions</b> .....	<b>3</b>
<b>1.4. Check for transportation damages</b> .....	<b>3</b>
<b>1.5. Transportation fixtures</b> .....	<b>4</b>
1.5.1. Removing the transportation fixtures .....	4
1.6. Use NSM Mounting Bracket .....	5
<b>1.7. Options and accessories</b> .....	<b>7</b>
1.7.1. Installing a MARS CASHFLOW 330 electronic coin acceptor (optional) .....	8
<b>1.8. Connecting the phonograph to the main voltage</b> .....	<b>9</b>
<b>1.9. Loading CDs into the CD storage magazines</b> .....	<b>10</b>
<b>1.10. Memorizing the titles of the loaded CDs to the control unit</b> .....	<b>11</b>
<b>1.11. Changing the price – and monetary value settings</b> .....	<b>12</b>
1.11.1. Programming the price settings, that means plays per price .....	12
Table 1: Programming of price settings .....	12
1.11.2. Example of Programming the monetary value settings .....	13
Table 2: Programming the monetary value settings .....	13
1.11.3. The "Credit" button .....	13
<b>1.12. Components of the NSM phonograph</b> .....	<b>14</b>
1.12.1. The playing instruction .....	14
1.12.2. The operating instruction .....	14
1.12.3. The 104–title display .....	15
1.12.4. The rocker button .....	15
1.12.5. Display and keyboard .....	16
1.12.6. CD changer .....	17
1.12.7. Central Unit .....	18
1.12.8. Control Unit .....	18
1.12.9. Audio system .....	19
<b>1.13. Remote control</b> .....	<b>20</b>
1.13.1. Setting the volumes .....	20
1.13.2. The key "MUTING" .....	21
1.13.3. The key "FREE CREDITS" .....	21
1.13.4. The key "BACKGROUND" .....	21
<b>1.14. Evaluation of the statistics</b> .....	<b>22</b>
1.14.1. Read–out of statistical values using the internal service program .....	22
1.14.2. Data transfer and storage with DATAprint .....	22
<b>1.15. Replacing and changing CD's</b> .....	<b>26</b>
<b>1.16. Connecting external loudspeakers in stereo mode</b> .....	<b>27</b>
1.16.1. Connecting additional loudspeakers with same impedance .....	27

1.16.2. Connecting additional loudspeakers of higher impedance .....	27
<b>1.17. Connecting external loudspeakers in mono mode .....</b>	<b>28</b>
1.17.1. Sound system for separate rooms .....	28
1.17.2. Mono mode with serial connected loudspeakers in one room .....	28
<b>1.18. Location of the stereo / mono switch .....</b>	<b>29</b>
1.18.1. Check that the phonograph is not overloaded .....	30
<b>1.19. Adjustments for better sound quality .....</b>	<b>31</b>
<b>1.20. Output transformer .....</b>	<b>32</b>
1.20.1. Extension Loudspeaker Operation .....	32
1.20.2. Selecting loudspeaker power .....	33
1.20.3. Definition of extension loudspeakers and their power consumption .....	33
Table 3: Calculation of the loudspeaker's power .....	34
<b>1.21. Connection diagram for output transformer .....</b>	<b>36</b>
<b>1.22. Adjusting the volume of additional loudspeakers using a "L-CONTROL" .....</b>	<b>37</b>
1.22.1. Independent control of more loudspeakers using L-CONTROL .....	37

<b>2.Section</b> .....	<b>1</b>
<b>2.1. Programming of special and individual settings</b> .....	<b>1</b>
<b>2.2. General information, command overview</b> .....	<b>1</b>
<b>2.3. Table of commands in program version V0107</b> .....	<b>2</b>
<b>2.4. The structure of the service program steps</b> .....	<b>6</b>
Table 5: Overview of commands of the service program .....	6
<b>2.5. Authorization (P001 to P002) / Show Version (P003)</b> .....	<b>7</b>
2.5.1. Enter Authorization Code .....	7
2.5.2. Changing the Authorization Code .....	7
2.5.3. Show version .....	7
<b>2.6. Statistics (P010 to P029)</b> .....	<b>8</b>
2.6.1. Popularity .....	8
2.6.2. Hit Parade .....	9
2.6.3. Contents of the statistical counters .....	9
2.6.4. Cashbox contents .....	9
2.6.5. Counter for number of coins / bills .....	9
2.6.6. Additional Counters .....	10
<b>2.7. Printout of the statistical data (P030 to P031)</b> .....	<b>11</b>
2.7.1. DATAprint, printout in text mode .....	11
2.7.2. DATAprint, printout in graphic mode .....	11
2.7.3. Display of error numbers while transferring/printing .....	12
<b>2.8. Clearing the statistical counters (P033)</b> .....	<b>12</b>
<b>2.9. Programming General Settings P040 to P057</b> .....	<b>13</b>
2.9.1. Default values .....	13
2.9.2. ID number of the phonograph .....	13
2.9.3. Maximum number of selectable CDs and tracks/titles .....	14
2.9.4. Limit play time of one track .....	14
2.9.5. Sequence of plays at normal selection .....	14
2.9.6. Maximum number of titles of one CD .....	14
2.9.7. Cancel credit .....	15
2.9.8. Cancel selection memory .....	15
<b>2.10. Sound system settings</b> .....	<b>16</b>
2.10.1. Maximum Volume Levels .....	16
2.10.2. Set volume for play mode .....	16
2.10.3. Sound setting .....	17
2.10.4. Maximum volume for microphone .....	17
2.10.5. Display the hitparade on the operators console display .....	17
2.10.6. Clear selection memory using remote control .....	17
2.10.7. Maximum volume for tape .....	17

<b>2.11. Price Settings P060 to P066</b> .....	<b>18</b>
2.11.1. Programming the price settings by default values .....	18
Table 6: Price Settings, predefined examples .....	18
2.11.2. Programming the price settings with custom settings .....	19
2.11.3. Programming an album bonus .....	19
<b>2.12. Monetary Value Setting P070 to P078</b> .....	<b>19</b>
2.12.1. Standard values .....	19
2.12.2. Individual monetary values .....	20
2.12.3. Bonus Credits .....	20
2.12.4. Indirect / direct money to credit revaluation .....	20
2.12.5. Programming the cash counter P013 and the electromechanical cash counter .....	20
Table 7: Monetary Value Settings, predefined examples .....	21
<b>2.13. Programming Real Time Clock P080 to P082</b> .....	<b>22</b>
2.13.1. Set time .....	22
2.13.2. Set date .....	22
2.13.3. Set day code .....	23
<b>2.14. Programming Free Credits P090 to P095</b> .....	<b>24</b>
<b>2.15. Programming Background Music P100 to P108</b> .....	<b>26</b>
<b>2.16. Programming Auto Play P110 to P117</b> .....	<b>28</b>
<b>2.17. Programming Advertisements P120 to P127</b> .....	<b>30</b>
<b>2.18. Programming Lock-Out Titles P130 to P135</b> .....	<b>32</b>
<b>2.19. Programming Happy-Hour-Credits P140 to P144</b> .....	<b>34</b>
<b>2.20. Initialization and Test Programs P150 to P159</b> .....	<b>35</b>
2.20.1. Test Programs for Service Operation P150 to P155 .....	35
2.20.2. Continuous run tests .....	35
Table 8: Error Displays .....	36
2.20.3. Additional test programs for the service operator .....	37
<b>2.21. Recording titles into title memory P160 to P163</b> .....	<b>38</b>
<b>2.22. Switching signal sources for testing the audio amplifier</b> .....	<b>39</b>
<b>2.23. Interface protocol for COM-port (Bacta-interface for GB only)</b> .....	<b>39</b>
<b>2.24. Animation via the title display P180 to 187</b> .....	<b>40</b>



# Section 1

1. Section

1.1. Overview of components

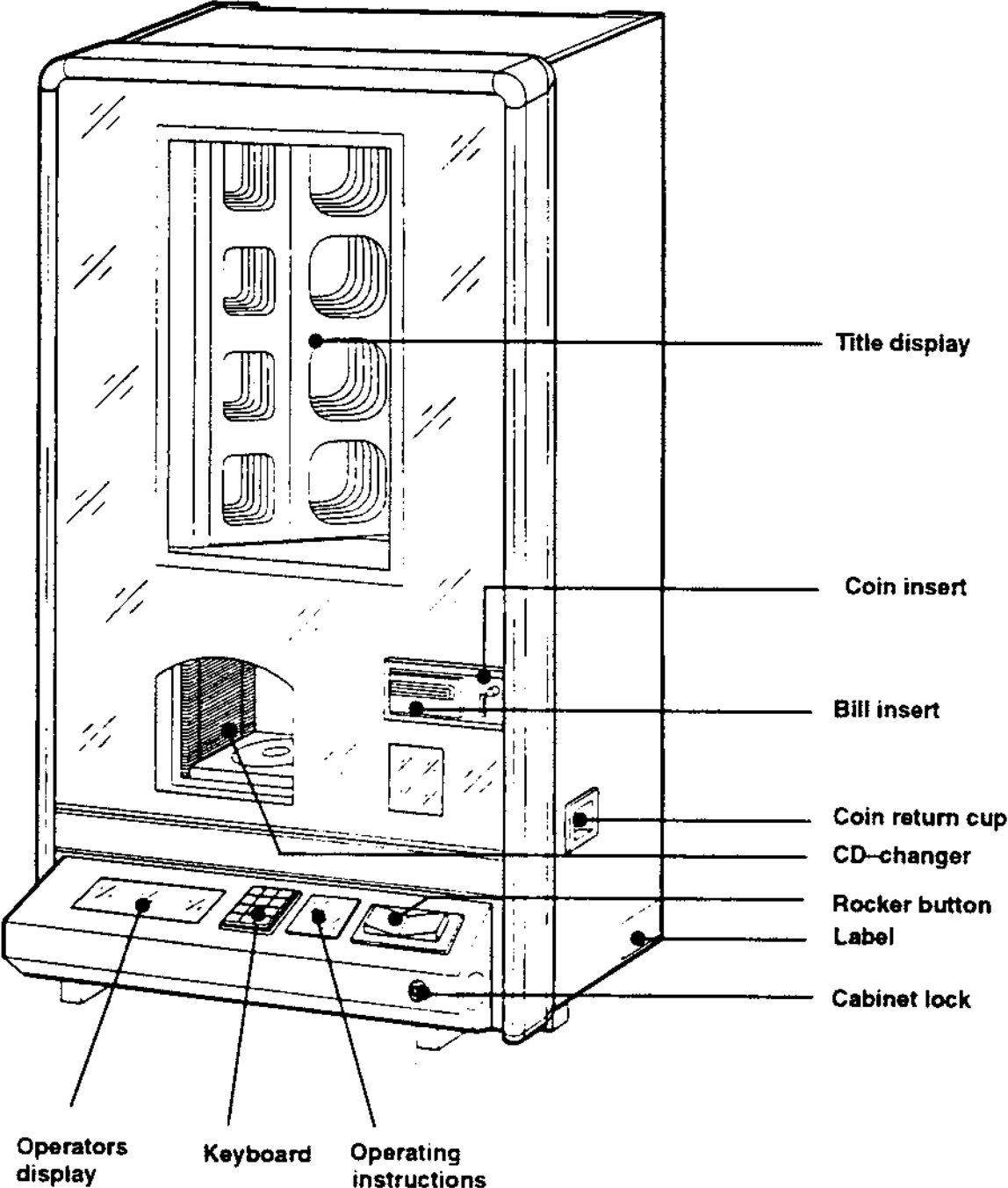

Figure 1: General view to the NSM phonograph. location of components

## 1.2. Technical data of the phonograph

### Electrical Data

Main voltage:		120 V factory setting
Frequency range:		60 Hz
Power consumption	stand by	120 W
	play mode	400 W
Music power	4 $\Omega$ load	2 x 200 W
Sine wave power	4 $\Omega$ load	2 x 125 W RMS (Sinus)

### Lighting

Fluorescent lamps	4 x 13 W
Lamps	12 V / 2 W

### Dimensions

Height	1042 mm $\approx$ 41"
Width	650 mm $\approx$ 25,5"
Depth	361 mm $\approx$ 14,2"

Weight	85 kg (unerrated)
--------	-------------------

### Credit / Cash Input

Maximum credit display is 99.  
 Price list adjustable.  
 Free credit adjustment / permanent credit.

### Keyboard

10 number keys	0-9
1 correction key	"C"
1 hit-step key	"H"

### Displays

Display 1 with 4 seven-segment LED's  
 Display 2 with 2 seven-segment LED's  
 Display 3 with 4 seven-segment LED's

1 lamp display each for indication of "10 top hits", "background", "credit", "your selection" and "error, press key "C"

### CD changer

NSM CD changer for up to 100 CD's. Disc-player: Philips CD-player unit

### Special Features

Computer-controlled amplifier protection for overload (mismatch).

### 1.3. Follow the following safety instructions

Remove all transportation security devices carefully from the phonograph and the CD-changer in order to avoid destruction and malfunctioning of it.

Level the phonograph carefully to avoid malfunctioning of the coin acceptor, the CD-changer and the title display unit.

**Be careful with the power supply.** Connect the phonograph only to the main voltage indicated on the label placed on the right hand side of the housing. Regard to change the lable entry if you change the wiring of the mains transformer (see section 3: Operating scheme of the phonograph "GEMFIRE").

Check the operating conditions. Storage and operation of this phonograph are recommended in dry rooms only.

### 1.4. Check for transportation damages

If the shipping carton shows damage due to transport, this should at once be recorded on the delivery slip of the shipping papers and then endorsed by the person making the delivery.

**Note:**            **The manufacturer is not liable for damages during transport!**  
                           **Take care to remove all transportation fixtures!**

4 ballast for 4 fluourescent lamps in front door at the left hand side of the housing.

Cash box behind dollar bill acceptor.

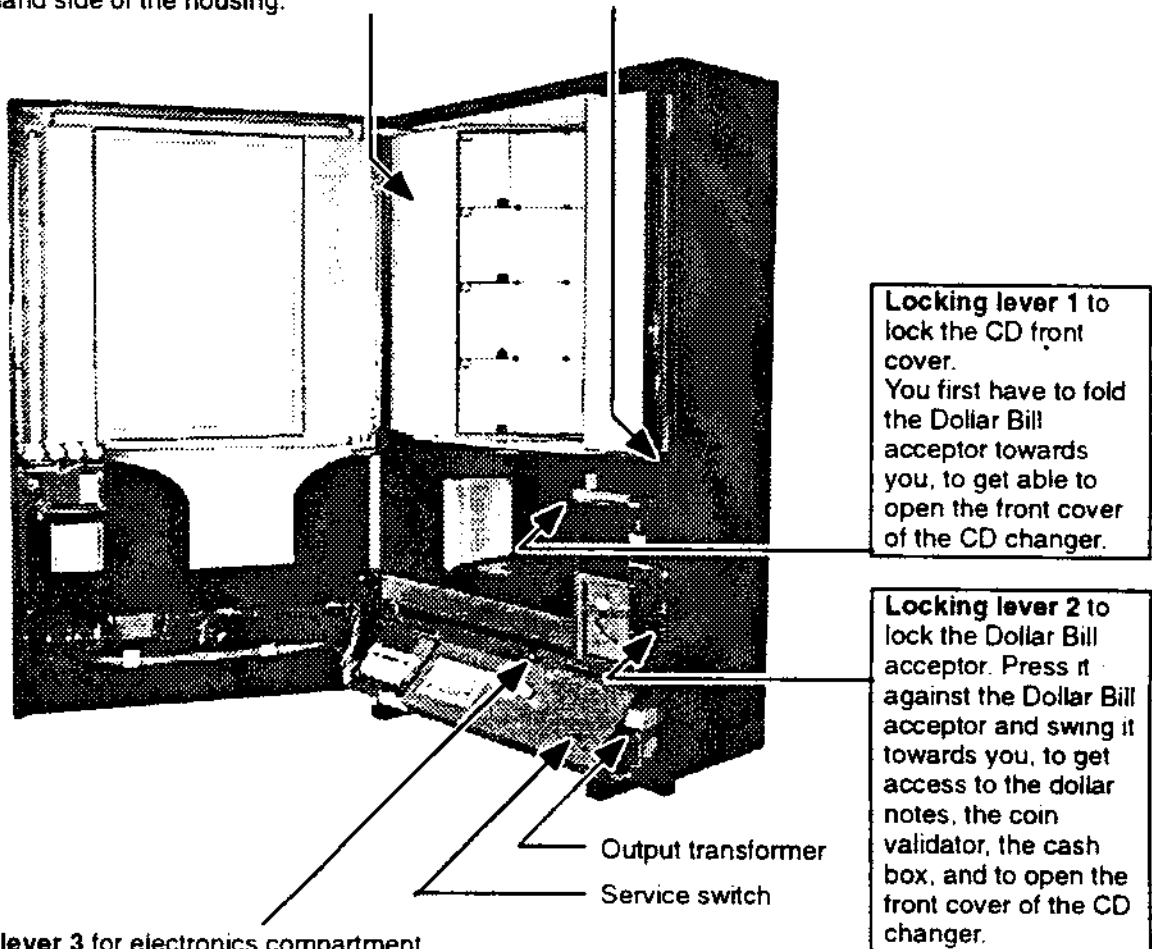

**Locking lever 1** to lock the CD front cover. You first have to fold the Dollar Bill acceptor towards you, to get able to open the front cover of the CD changer.

**Locking lever 2** to lock the Dollar Bill acceptor. Press it against the Dollar Bill acceptor and swing it towards you, to get access to the dollar notes, the coin validator, the cash box, and to open the front cover of the CD changer.

**Locking lever 3** for electronics compartment. Unlock position = upwards. Fold cover plate towards you to get access to the electronics, the MIC-Adaptor, the output taps of the output transformer.

Figure 2: View inside the opened phonograph

## 1.5. Transportation fixtures

Before operating the phonograph all transportation fixtures for safety and protection during transport have to be removed. Regard information given in figure 2 and figure 3.

**Note:** Prior to any further transportation the security devices for safety and protection during transport have to be re-inserted.

**Avoid static discharge** to the phonograph. Electro Static Discharge (ESD) may destroy the opto-electronics and other ESD sensitive parts within the phonograph.

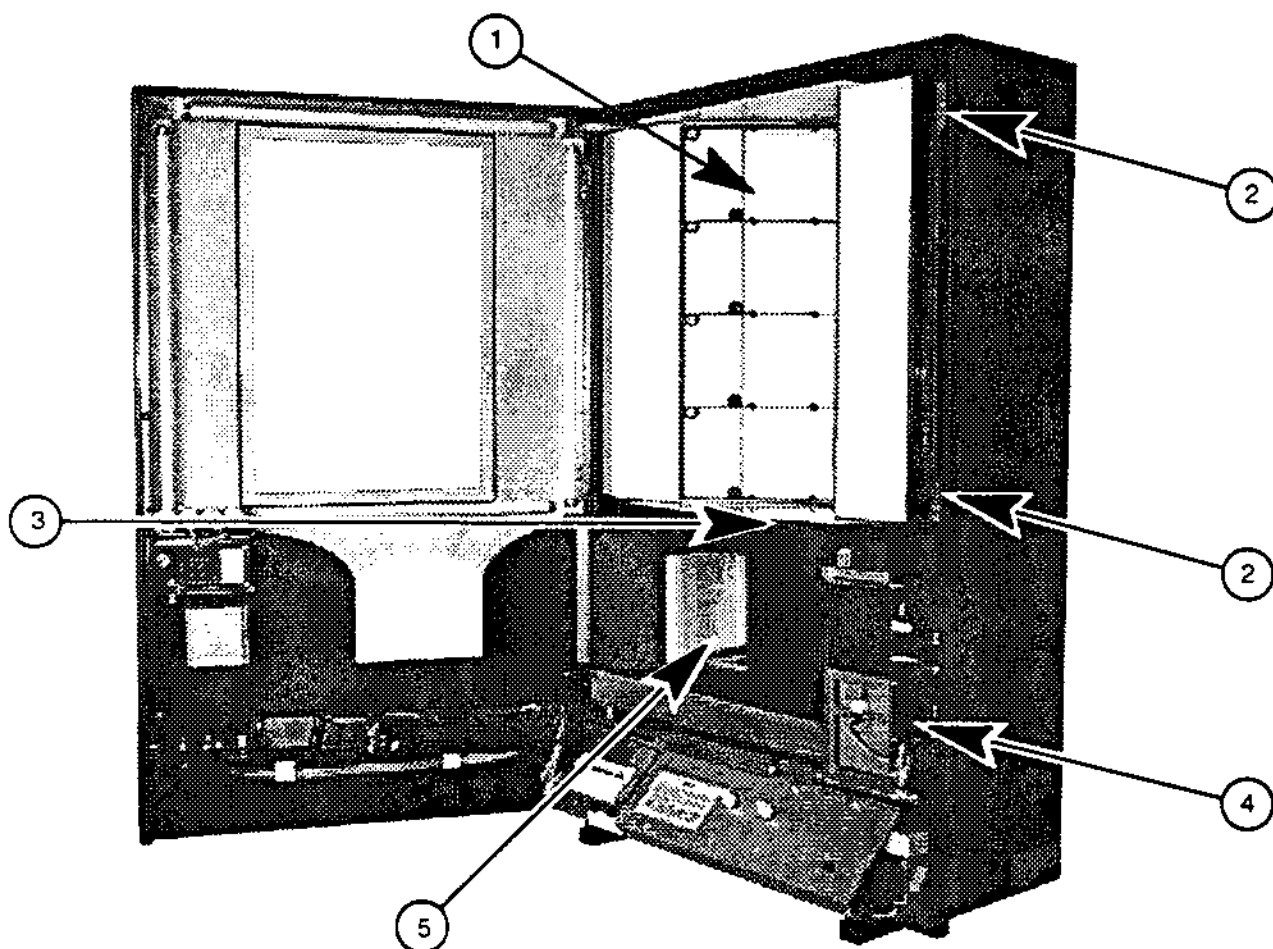

Figure 3: CD changer, transportation fixtures

### 1.5.1. Removing the transportation fixtures

1. Open the phonograph. Turn the key and swing the door to the left.
2. Remove the card board transportation fixture from the title display (1).
3. Remove the two transportation security screw (2).
4. Lift the title display a little and swing it to the left side ( direction front door) to get access the the transportation security screw (3) of the CD-changer and remove this screw also.
5. Fold the Dollar Bill acceptor towards you (4), to open the front cover of the CD-changer.
6. Remove the card board transportation fixture (5), located between the two CD magazines.
7. Swing both handles of a magazine to the front together if you want to take out a magazin.
8. Press the corresponding black knob to the outer side.
9. The magazine automatically jumps out of the locking device and can easily be removed out of the changer. Take out the CD magazine.
10. Remove all adhesive strips from the sockets of the fluorescent lamps and starters.

## 1.6. Use NSM Mounting Bracket

In order to guarantee a correct functioning of the coin mechanism mount the phonograph horizontally and vertically exactly.

Therefore, we recommend the practical NSM mounting bracket (Part-No. 040 739).

Take care to mount the bracket untwisted since the rear of the cabinet can otherwise be twisted.

To secure the phonograph to the bracket, a holding screw with sleeve –Part No. 176 999 (M 10x20)– of the accessory bag is to be used.

Plug in connection cable before mounting (refer to section 3: "Mains Connection").

Secure mounting of the machine is very important since besides the danger of severely damaging the machine, the operator is responsible for all damages caused by an incorrectly mounted wallbox.

When choosing the fastening material, take into account the machine's weight.

We recommend dowel pins in sufficient quantities.

The screws should be at least 6 mm in diameter!

Example of mounting the NSM mounting bracket using nylon dowel-pins

First a few tips:

- The maximum bearing capacity of nylon dowel pins may only be achieved with the greatest possible screw diameters and with screws exceeding the dowel point by the screw diameter again.
- Please ensure that with fixings in hollow brick and hollow blocks the expansion zone of the dowel is completely anchored in at least one stone web.
- Determination of minimum screw length  
 $1 \times d$  (d=nominal diameter of screw)  
 + dowel length  
 + thickness of plaster and/or insulating material  
 + thickness of mounting bracket 3 mm  
 = min. screw length

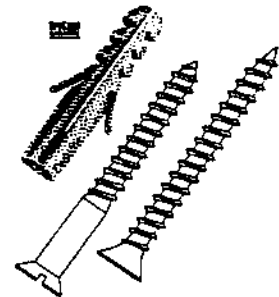

Important :

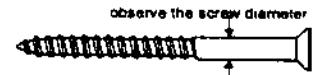
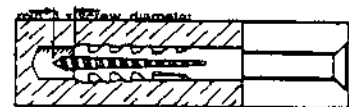

### Pull-out values, safety factors

The pull-out values (breaking loads) given in this chapter are mean failure loads determined in at least 5 tests in uncracked building material.

Failure criteria may be: failure of building material, breaking of bolt, loosening of anchor, breaking of anchor

Pull-out values in kN\*. Determined in each case with the largest screw diameter (steel screw) and with flush fixing of the dowel in the load-bearing anchorage base.

The following points must be observed when drilling, irrespective of the material.

Dowel	S8
Wood screws 2	6 mm
Concrete B25	4,5 kN
Aerated concrete GB 3.3	1,2 kN
Aerated concrete G 4	1,3 kN
Solid brick Mz20	4,1 kN
Perforated brick Hlz20	3,0 kN

Allowance must be made for an appropriate safety factor.

### Drill hole geometry

The exact drill hole geometry dictates the load-bearing capacity of a dowel. Therefore always drill at right-angles and do not change direction during drilling. This has especially to be observed in the case of soft materials.

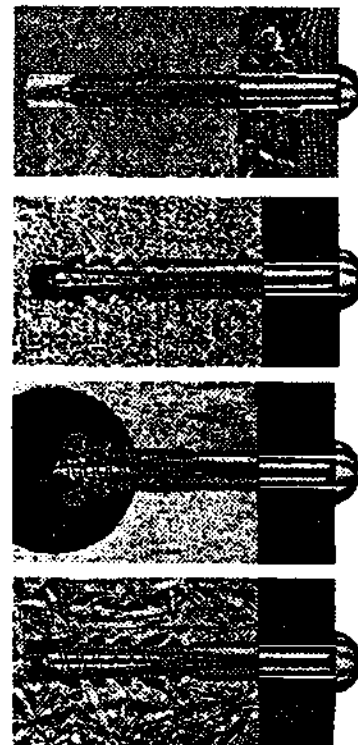

## Drill process

The following drilling methods are possible depending on the type of drilling machine:

- Rotary – without impact
- Impact drill – many impacts with a low amount of impact energy. Fast rotation
- Hammer drill – few impacts with a high amount of impact energy. Slow rotation

The material determines the drill process:

- Solid materials of dense structure: impact and hammer drilling
- Hollow brick, materials of low strength and aerated concrete, only rotary so that the hole does not become too big and in hollow brick the webs do not break out.

Never forget to remove the dust from the drill hole after drilling. Only then the dowel performs safety fixing.

As a safety factor we recommend: for nylon dowel pins  $v \geq 7$ .

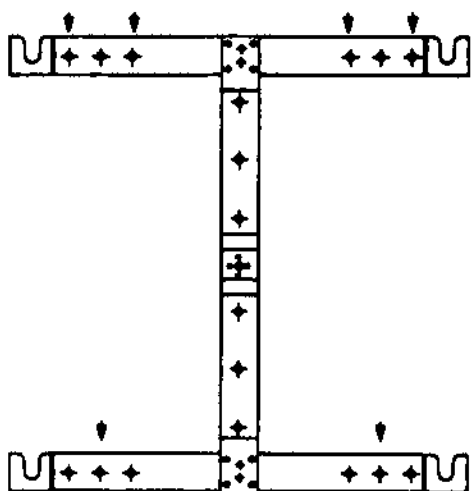

Example: In aerated concrete GB 3,3 the pull-out value for dowels type S8 and screws with a diameter of  $\varnothing = 6\text{mm}$  is 1,2 kN. Divided by safety factor 7 becomes

$$1,2 \text{ kN} / 7 \approx 0,17 \text{ kN} = 17 \text{ kp for 1 screw.}$$

The weight of the machine is nearly 85 kg; therefore at least

$$85 / 17 \approx 5 \text{ screws are necessary.}$$

For additional safety reasons and for better symmetry you should use 6 screws. Also see arrows in left hand figure.

When fixing the machine to the wall, make sure the vent is not hindered in its function. When using the mounting bracket, there is normally enough distance between cabinet and wall for air circulation. Plush wall hangings decrease this distance; in that case the bracket has to be fastened to a flat board. Do not mount machine above heaters!

1.7. Options and accessories

Description	Part-No.:
<p><b>Infrared-Remote Control</b> (with 5 m cable to receiver)                      The following functions are possible: Volume, Free credit, Reject muting and Background</p> <p>Substitute connection cable 2m                      Connection cable 5m                      Connection cable 1,5m</p>	<p>177 491</p> <p>170 266                      170 459                      171 883</p>
<p><b>DATAprint 3000S</b> (with thermal printer, German version)</p>	<p>118 197</p>
<p><b>Wired remote control</b> with 5 m cable                      This phonograph can also be controlled via a wired remote control. The following functions are possible: Volume, Free credit, Reject muting and Background</p>	<p>171 743</p>
<p><b>Volume control</b>, for operating outside of the phonograph                      3 keys (Volume +/- and Reject) in a handy box with 0,5m connecting cable (4-poles, easy to extend if necessary).</p>	<p>170 212</p>
<p><b>Output transformer</b>                      Extended possibilities for connecting more loudspeakers (parallel circuit).                      Less wire losses due to 70V-exit (also possible for 100V-systems).</p>	<p>177 450</p>
<p><b>MIC-Adaptor</b>                      Use this MIC-Adaptor for connecting a dynamic microphon with an impedance of 200Ω-600Ω; Or connect a tape recorder /-player or an additional amplifier.</p>	<p>177 488</p>
<p><b>Microphon</b>, with paging switch (without cable)                      Connecting cable 10m. assy. with plug and socket for microphon                      Connecting cable 20m. assy. with plug and socket for microphon                      Plug for MIC-Adaptor                      Socket for microphon</p>	<p>224 223                      171 880                      172 187                      225 260                      225 758</p>
<p><b>Key-Switch</b>                      serves as protection against unauthorized calling up of free credits and switching on the background mode.</p>	<p>177 486</p>
<p><b>Cash counter</b>                      Electro-mechanical cash counter for counting the incoming monetary values.</p>	<p>173 348</p>
<p><b>Cable harness</b>                      For building a remote selection for NSM Selector boxes</p>	<p>178 979</p>



1.7.1. Installing a MARS CASHFLOW 330 electronic coin acceptor (optional)

This phonograph may be equipped with an electronic coin acceptor to check up to 4 or 5 different coins, depending on the type of the coin acceptor.

The three sensors in the validator register each separately thickness, material quality and diameter of each deposited coin. If an inserted coin has passed the sensors, the determined data are compared with the information of valid coins stored in the PROM of the coin acceptor. If the validation criteria are identical with a data set stored in the PROM a "valid signal" is generated.

Depending on the coin value the valid signal is sent as output signal IB to IF to the CB ADAPTER. From there the signal reaches plug ST8 of the control unit.

The monetary value settings of the individual program steps are assigned to corresponding output signals:

- P071 to signal IF
- P072 to signal ID
- P073 to signal IC
- P074 to signal IE
- P075 to signal IB

*Note:* When inserting a coin during program steps P070 to P075, the program step assigned to this coin is automatically represented in display 1.

The monetary values are programmed in monetary value units. For details see programming section.

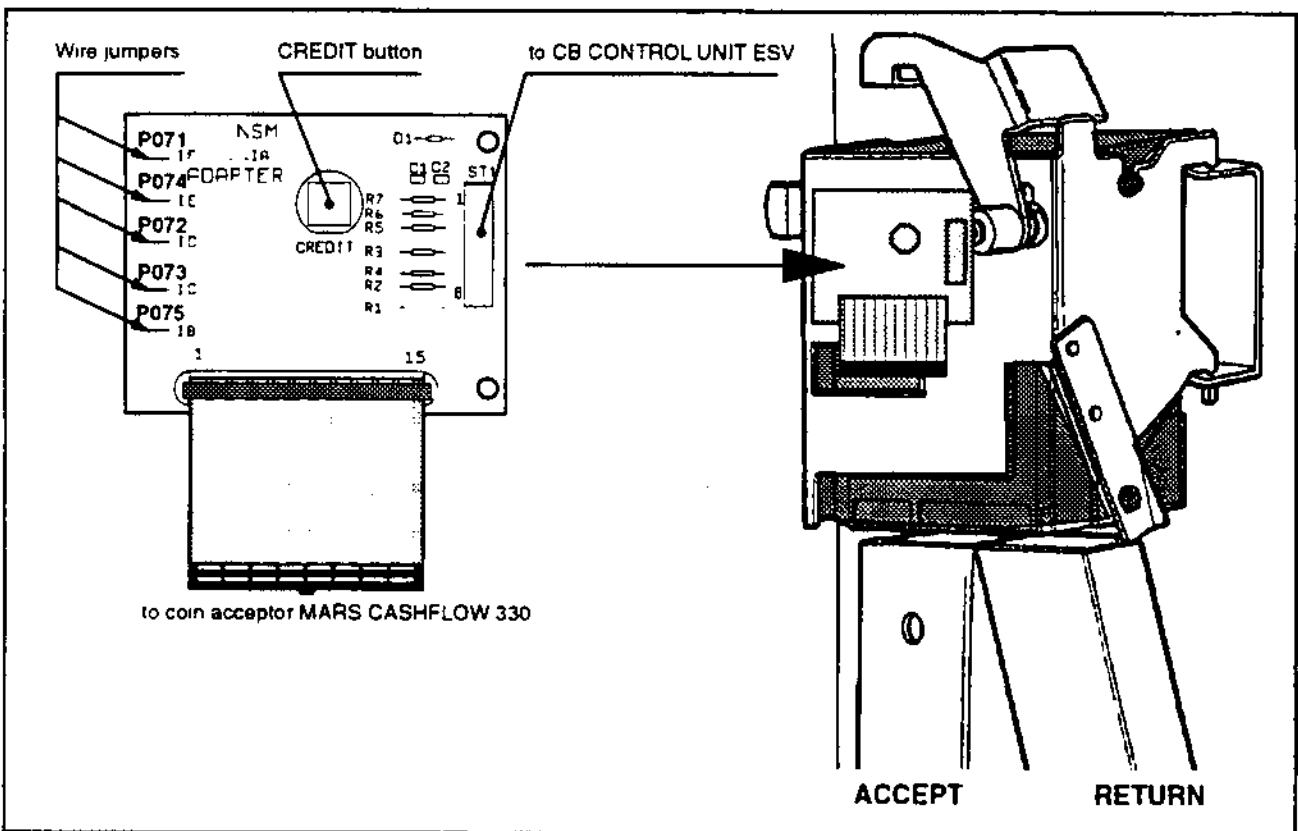

Figure 4: Installing a MARS CASHFLOW 330 coin acceptor using the CB ADAPTER

*Note:* To avoid misuse or manipulation non-used channels are to be programmed with "0" and also should be blocked mechanically.

For this purpose the soldered wire jumpers of the corresponding channels IB to IF on the CB ADAPTER have to be cut.

## 1.8. Connecting the phonograph to the main voltage

**Note:** *Check main voltage before connecting the phonograph!*

The label placed on the right hand side of the phonograph near the bottom shows the factory setting of the mains voltage.

**Attention:** **To protect your phonograph or any connected device from any damages please follow:**

**Before you connect any device, or before you make any changes to the connection between the phonograph and a device, please make sure to switch off the power supply of the phonograph and any connected device (i.e. external audio amplifier).**

**Otherwise damages may be caused to the phonograph and/or the connected device(s).**

**Danger:** **The green–yellow wire of the three–wire power cord must be connected to the ground (protective earth) according to the international safety code.**

On main voltage fluctuation of  $\pm 10\%$  the phonograph operates correctly.

On higher main voltage fluctuation you have to add a voltage stabilizer having a power output of 500 VA (Watt) at minimum.

For constant under voltage or over voltage and for other desired voltage settings you have to re–wire the mains transformer of the phonograph → see wiring diagram sticker near the transformer.

The wiring of the ballast for the fluorescent illumination must not be changed!

If you have changed any voltage setting then you have to note this new setting to the label on the rear side near the power connector.

The power switch is located at the bottom of the housing at the left hand side. After having established the necessary connections, switch on the phonograph. The fluorescent lights should now light up.

The phonograph is now ready to operate

## 1.9. Loading CDs into the CD storage magazines

Open the phonograph if not already done.

In order to avoid movement of the lift (attract mode) while working within the CD changer pull out the service switch. Now the phonograph is in service mode.

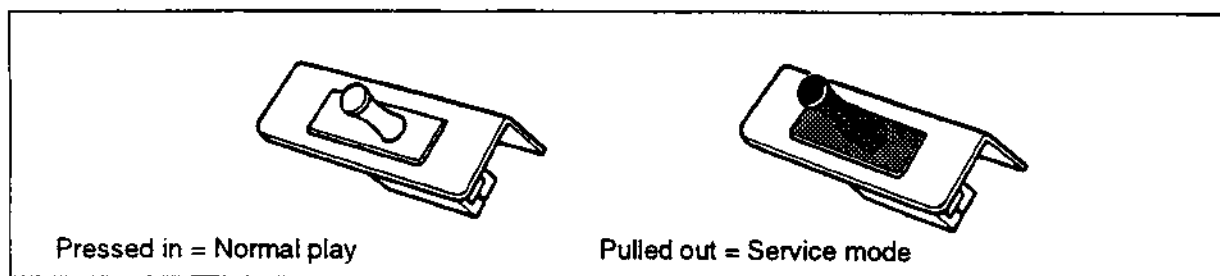

Figure 5: Positions of the service switch

The magazines are equipped with tilting handles; simply fold the two handles to the front if you wish to take out a magazine.

Remove the right-hand storage magazine by holding the handles with your right hand and pressing the right-hand knob to the right side. The magazine automatically jumps out of the lock.

Remove the left-hand storage magazine by holding the handles with your left hand and pressing the left-hand knob to the left side. The magazine audibly jumps out of the lock.

Remove a number of CD trays corresponding to the number of CDs you wish to insert into the magazine. **Always place the CDs face up** (label up) into the recess of each tray, and thereupon slide the tray into the first available slot of the magazine.

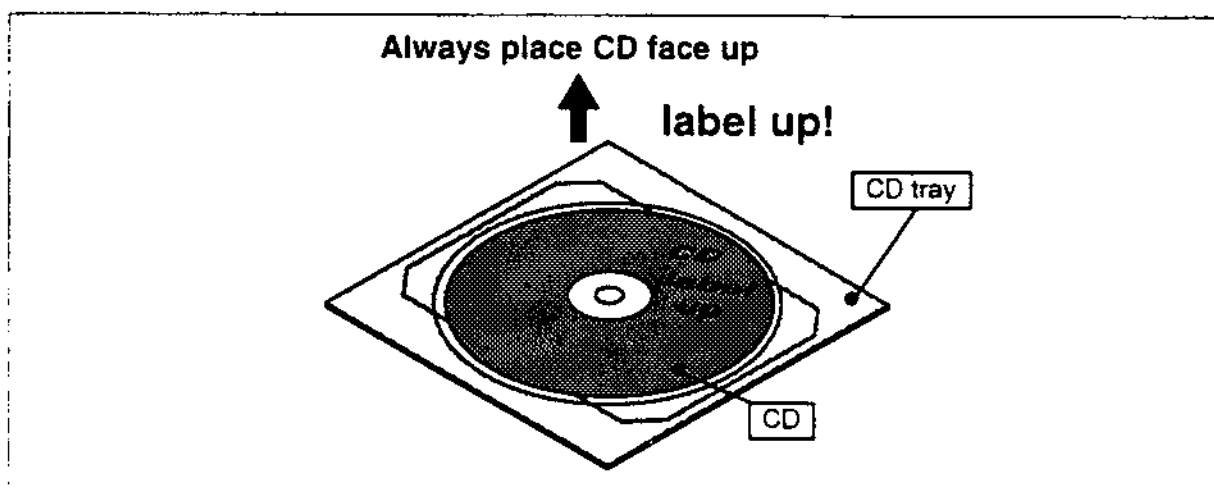

Figure 6: Placing CDs into CD trays

**Note:** *CDs have to be placed label up into the CD trays. Otherwise the CD changer will cause an error when accessing an incorrectly inserted CD.*

When re-inserting the magazines take care that each magazine locks automatically with a slight bump in the locking device. If you don't push in the magazine strong enough, a disfunction of the CD changer may result!

**Note:** *Due to the CD magazine's construction they can be transported outside the CD changer without any special transportation securities. Only when treated too rough the CD holders will fall out of the locking devices within the magazine.*

**Please don't store or transport magazines upside down.**

### 1.10. Memorizing the titles of the loaded CDs to the control unit

The memorization of the title information of the loaded CDs takes place within service program step P160.

If the phonograph is not yet in service mode,

- open the cabinet lid (door) and
- pull out the service switch (refer to fig.5)

Now the phonograph is in service mode. The display shows e.g.:

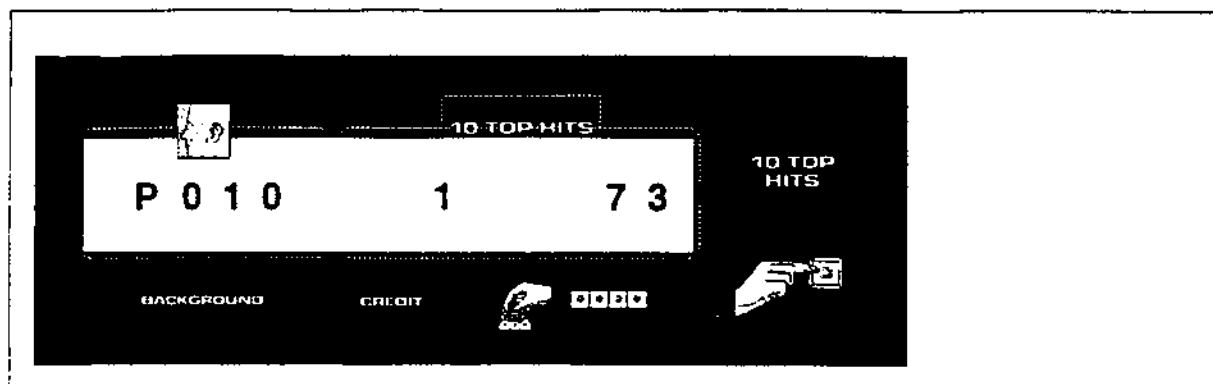

Figure 7: Display after entering the service mode

Perform the following steps in order to start the initialization:

- press "C"      display shows P \_\_\_\_ \_
- enter P160    display shows P160
- press "H" and "0"      to start the memorization

The control unit of the phonograph then checks every tray, one after another, of both CD storage magazines to read the information from the inserted CD concerning the number of tracks.

**Note:**      The control unit searches all CD trays up to the number of CDs specified in P042.  
                  The factory setting of the value in P042 is 0032, which means 100 CDs with 32 tracks each.  
                  If you have not installed 100 CDs, you must first change the number of accessible CDs and tracks in P042.

**Take care** that you do not leave CD trays empty in the selected number of CD's in P042.

After starting the initialization routine the phonograph needs less than 15 minutes to check all CDs. During this routine you may close the cabinet door. The phonograph returns automatically to the normal play mode after finishing the initialization procedure. If money is inserted during that time it will retain the number of credits but selections cannot be made during the memorization process.

**1.11. Changing the price – and monetary value settings**

The following text is a short description of the program steps P060 to P066 and P070 to P075. The detailed description and corresponding tables are contained in chapters "Price Settings" and "Monetary Value Settings" in section 5: "Programming".

**1.11.1. Programming the price settings, that means plays per price**

Example for setting the price settings:           1 play = 25 c  
   2 plays = 50 c  
   5 plays = 1 \$  
   no discount for album selection

Table 1: Programming of price settings

Programming information	Action of the operator	Displays		
		1	2	3
Enter the service mode of the phonograph	pull out the service switch	P010	_1	_73
			Play	price
Clear display and enter the following commands:	C	P__	__	__
Direct selection of a command, display of previous setting in P061.	61H	P061	_1	0100
Enter new setting in P061 "1 play/25c".	010025	P061	01	0025
Confirm setting and advance to next command, display shows previous setting in P062.	H	P062	_1	0100
Enter new setting in P062 "2 plays/50c".	020050	P062	02	0050
Confirm setting and advance to next command, display shows previous setting in P063:	H	P063	_3	0200
Enter new setting in P063 "5 plays/1 \$".	050100	P063	05	0100
Confirm setting and advance to next command, display shows previous setting in P064:	H	P064	03	0200
If setting is not used enter "0".	0	P064	__	__0
Confirm setting and advance to next command, display of previous setting in P065:	H	P065	03	0200
If setting is not used enter "0".	0	P065	__	__0
Confirm setting and advance to next command, display shows current setting for P066 (album selection without discount).	H	P066	__	__1

After confirmation of a setting (e.g. for P062) the system automatically turns to the next program step (here: P063).

**Caution!** Press "C" key in the event of incorrect programming or when display flashes (Error press C).

If you want to terminate the changing of settings you have to press the "C" key twice or close the cabinet door to **return to standard operating mode (play mode)**.

### 1.11.2. Example of Programming the monetary value settings

Depending on the type of coin acceptor the individual coin channels must be programmed for the associated monetary values in the corresponding program steps. Unused channels must be programmed with the monetary value "0"!

**1. Checking the monetary value settings:** Select one program step between P070 and P075. After inserting any coin the channel associated with the coin is displayed, e.g. 50 cents in channel 2: display P072 0050.

**2. Changing the monetary settings:** As an example, if the 25 cents slot (channel 1) is not to be used: First enter program step P071 as described above. In the coin acceptor or on the adaptor PCB of electronic coin acceptors the respective channel has to be blocked so that these coins drop into the coin return.

**3. Standard settings:** The programming of standard settings is done with the command P070 and entering the number of the desired table values (see table 7 "Monetary value settings" in section: "Programming"). The correct programming of all channels is done automatically after entering the number and pressing the key "H".

The way inserted coins are counted on an electronic cash counter is set to "monetary value /100" (P078 is set to "0").

Table 2: Programming the monetary value settings

Programming information	Action of the operator	Displays		
		1	2	3
Enter the service mode of the phonograph	pull out the service switch	P010	_1	_73
Clear display and enter the following commands:	C	P	__	__
Direct selection of a command. display of previous setting in P071.	See text (2.)	P071		_500
Enter new setting: no coin conversion within channel 1	0	P071		_0
Confirm setting and advance to next command. display of previous setting in P072.	H	P072		_500
If the standard setting according to the table of monetary standard settings is to be used, call up program step P070 (as described previously).				
Ready for standard setting P071 through P075	See text (3.)	P070		xxxx
Program entry "10" of the standard table (for USA mechanical coin acceptor).	10H	P070		_10
Confirm setting and advance to next command	H	P071		_010

**Caution!** Press "C" key in the event of incorrect programming or when display flashes.

If you want to terminate the changing of settings you have to press the "C" key twice or close the cabinet door to **return to standard operating mode (play mode)**.

### 1.11.3. The "Credit" button

The phonograph also offers a so-called **free-credit button**, located on the CB adaptor (see fig. 4) with electronic coin acceptors. Action on this button is only possible when the phonograph is in service mode. Pressing the credit button once gives "1 free credit". Credits generated by pressing the credit button are not registered statistically. In phonographs using a mechanical coin acceptor you will not find a free-credit button. You can push the micro switch beneath the coin acceptor instead.

## 1.12. Components of the NSM phonograph

In the following chapter you shortly will be introduced to the main components of the NSM phonograph. (Refer to figure 1 and 2 for locating the several components.)

### 1.12.1. The playing instruction

To earn credits for playing different titles you have to insert either coins or bills.

You also have the possibility to change the number of credits for a title selection or an album selection. Then you have to replace the corresponding credit stickers with new ones.

Note: If you wish to change any credit setting don't forget to change the playing instructions.

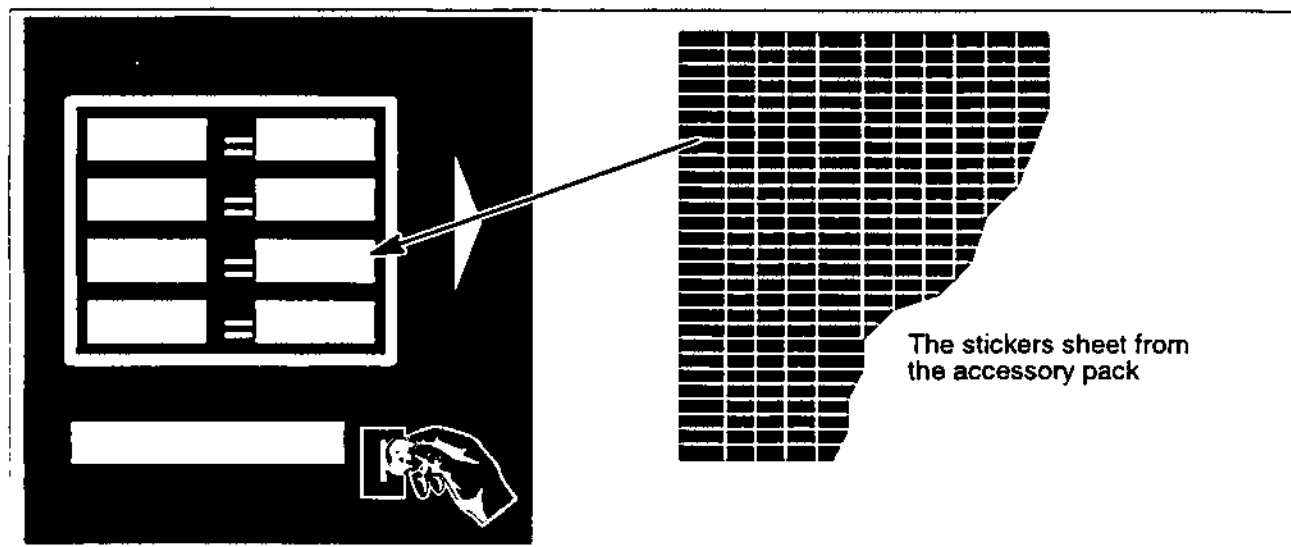

Figure 8: The playing instruction of the phonograph

### 1.12.2. The operating instruction

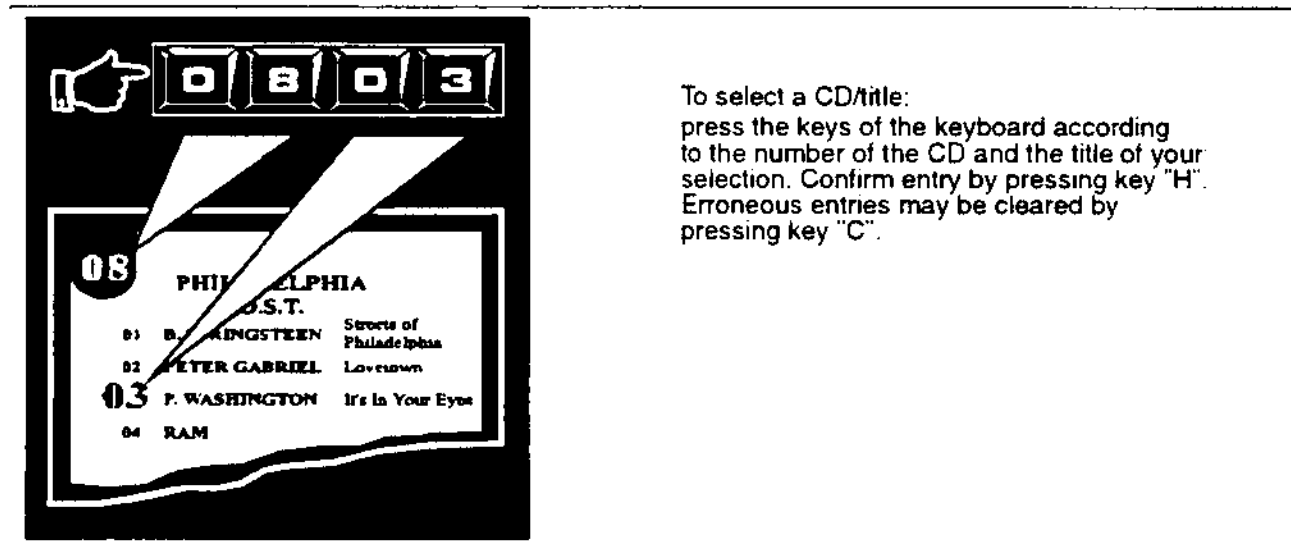

Figure 9: The operating instruction of the phonograph

### 1.12.3. The 104-title display

The title display consists of 14 carriers and is capable of storing up to 104 (13x8) CD covers and title strips. If you want to insert or remove title strips and/or CD covers you first have to open the phonograph.

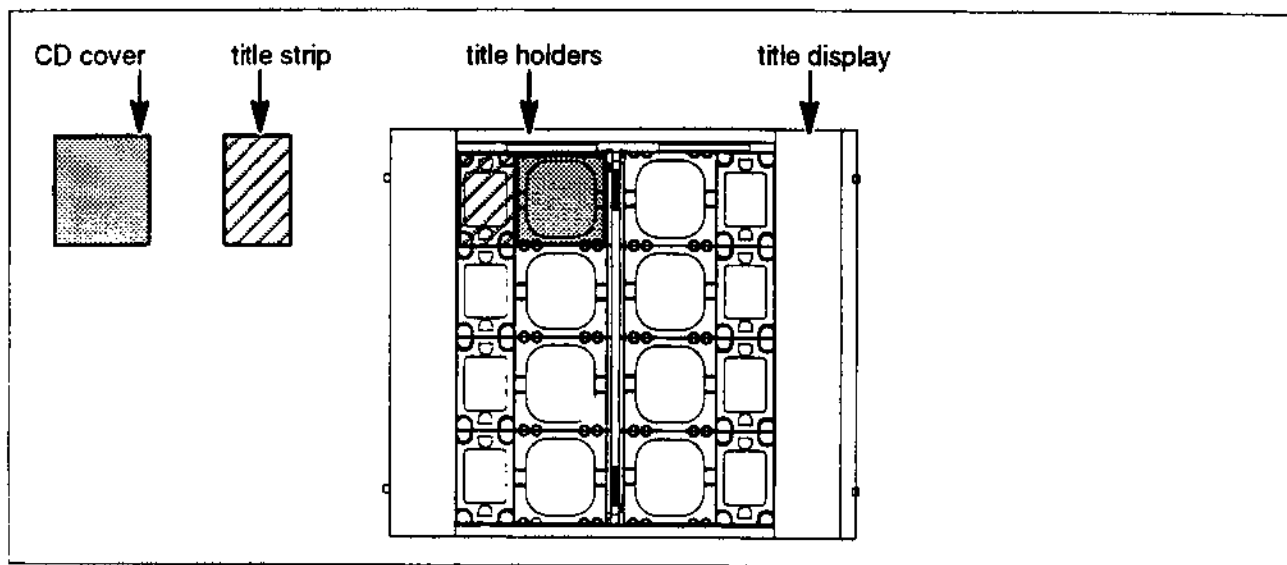

Figure 10: Loading title strips and CD covers

You have to be careful while inserting the CD covers and title strips into the title holders. Be sure CD covers and title strips are inserted under all the black plastic tabs. This will insure that they don't fall out. The title display will always show eight covers of inserted CDs. You have to press the rocker button, placed in the operators console of the phonograph, if you want to move the title holders within the title display. In case of a limitation of selectable CDs by programming P042 (refer to chapter **Programming of the phonograph**), you have to take care to insert only the corresponding number of title strips and CD covers.

### 1.12.4. The rocker button

The title holders can be moved into the corresponding direction by pressing the rocker button in the operator's console. Upon each button operation sixteen new CD-covers including title strips are shown. Lamps inside the rocker button will light showing the possible direction of moving the title holders.

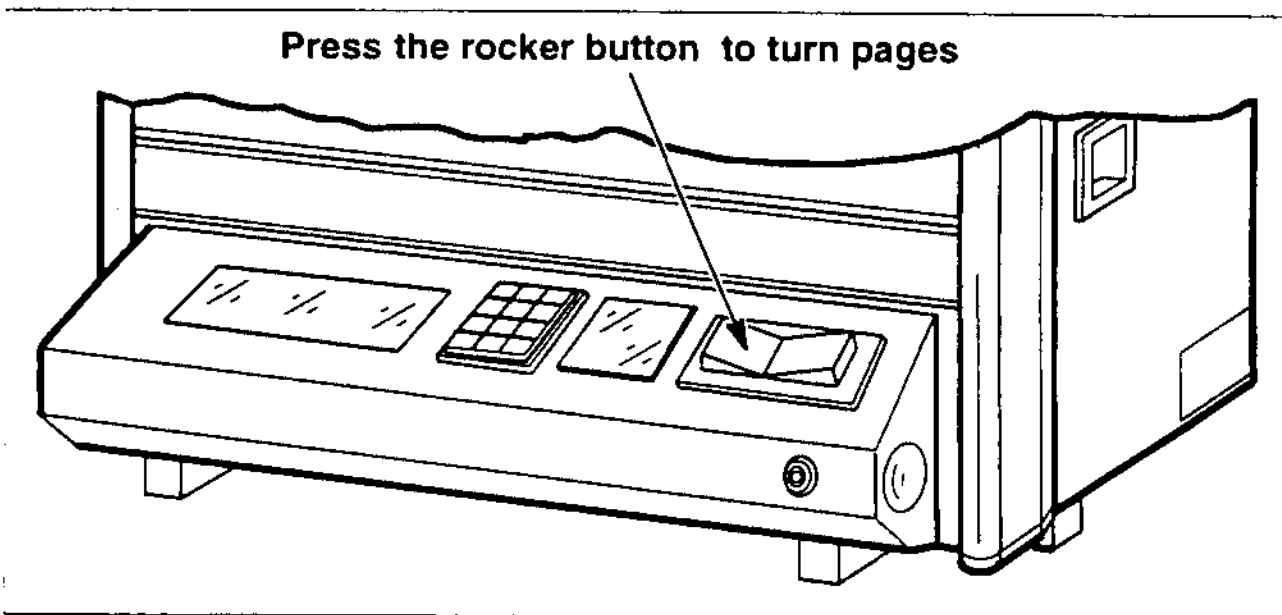

Figure 11: Locating the rocker button



### 1.12.5. Display and keyboard

In the operators console you will find a keyboard with digits "0" to "9" and "H" and "C". The multi-functional display consists of three parts. You will get different information via the display depending on the mode of operation of the phonograph:

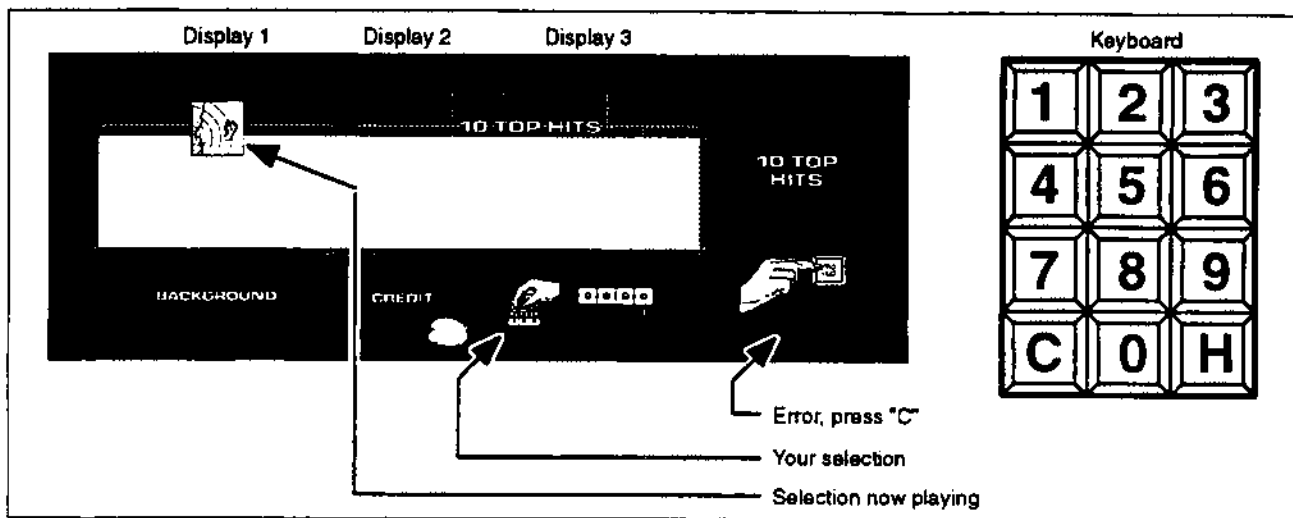



Figure 12: Display and keyboard in the operators console

Immediately after power-on the phonograph performs a self-test of the memory components of the control unit and all pre-programmed values. Afterwards display 1 shows the program version of the phonograph software for 2 sec. If an error is found during the self-test, the error code is displayed as "Er xx" for 2 sec. With Er 31 (unverified memory contents) and Er 40 (price settings incorrect) display 1 shows the program step which needs to be re-programmed as Pxxx.  
**Note:** For other Er-numbers on display 3, even during operation, refer to section 3 to get more information about error locating or trouble shooting.

During stand-by the phonograph calculates the ten most played titles out all titles played. On display 3 the title numbers of the 10 most popular titles are shown the rankings (1-10) are shown on display 2 (if enabled in P56). This "hit display" is changed in intervals of 2 sec. Also the lamp "10 top hits" lights up.  
 When pressing the key "H", the hit display can be stopped for 16 sec. Each pressing of the key "H" causes an advance to the next hit  
**Note:** When the popularity counters are erased (program step P033), the hit parade is erased, too. In that case "0" appears for ranking until CD's are played again.

After insertion of a coin the hit display is interrupted, the lamp "10 TOP HITS" turns off, and the lamps "credits" and "your selection" (  ) light up. Display 2 shows the number of credits.  
 For every selection credit is deducted. If not enough credits are available for the selection, the lamp "credit" flashes. No more coins being inserted within 16 sec. or no selector key being pressed, the mode changes back to "hit display".

After selection of a title the CD to be played is transported to the player and then played.  
 Just before start the number of the title is shown on display 1 ("SELECTION NOW PLAYING"). After the disc has been played, the display is erased and the CD is transported back to its magazine space.  
**Note:** If an error occurs with the CD changer or the player, "Er 7x" or "Er 6x" appears for 2 sec. In that case refer to section 3 to get more information about error locating or trouble shooting.

During programming mode the display shows the selected programming step with actual values. Use the keyboard to change settings (refer to section 2 to get more information on programming).  
**Note:** Programming is possible only if the phonograph is in service mode.

### 1.12.6. CD changer

The CD changer used within this phonograph is our fast 100 CD changer "MBC III-Pro". This high quality product uses two CD storage magazines capable of storing max. 50 CDs each. A simple locking mechanism is integrated to hold the two CD storage magazines.

Refer to figure 13 to get familiar to the location of the components. You will need this information later when loading CDs.

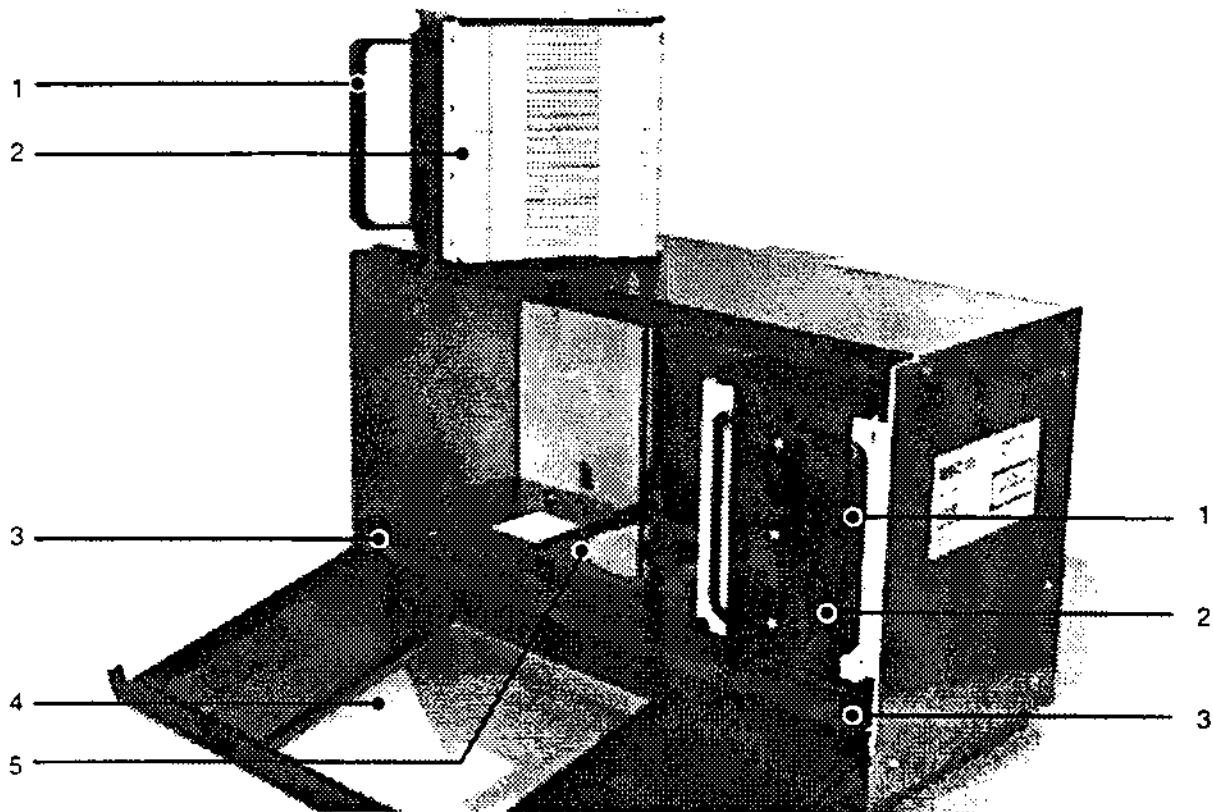

Figure 13: CD changer

The components are

- 1 = Handle of the CD magazine
- 2 = CD magazine
- 3 = Locking lever for CD magazine
- 4 = Front door of the CD changer
- 5 = CD lift

### 1.12.7. Central Unit

The power supply, stereo amplifier with fan control, interfaces for the inputs of microphone, CD drive, tape and remote control, interfaces for the output to control unit, CD drive, and illumination are all integrated on one circuit board "CENTRAL UNIT ES5.1".

The music power per channel is 200 Watt when matched to a loudspeaker impedance of 4 Ω.

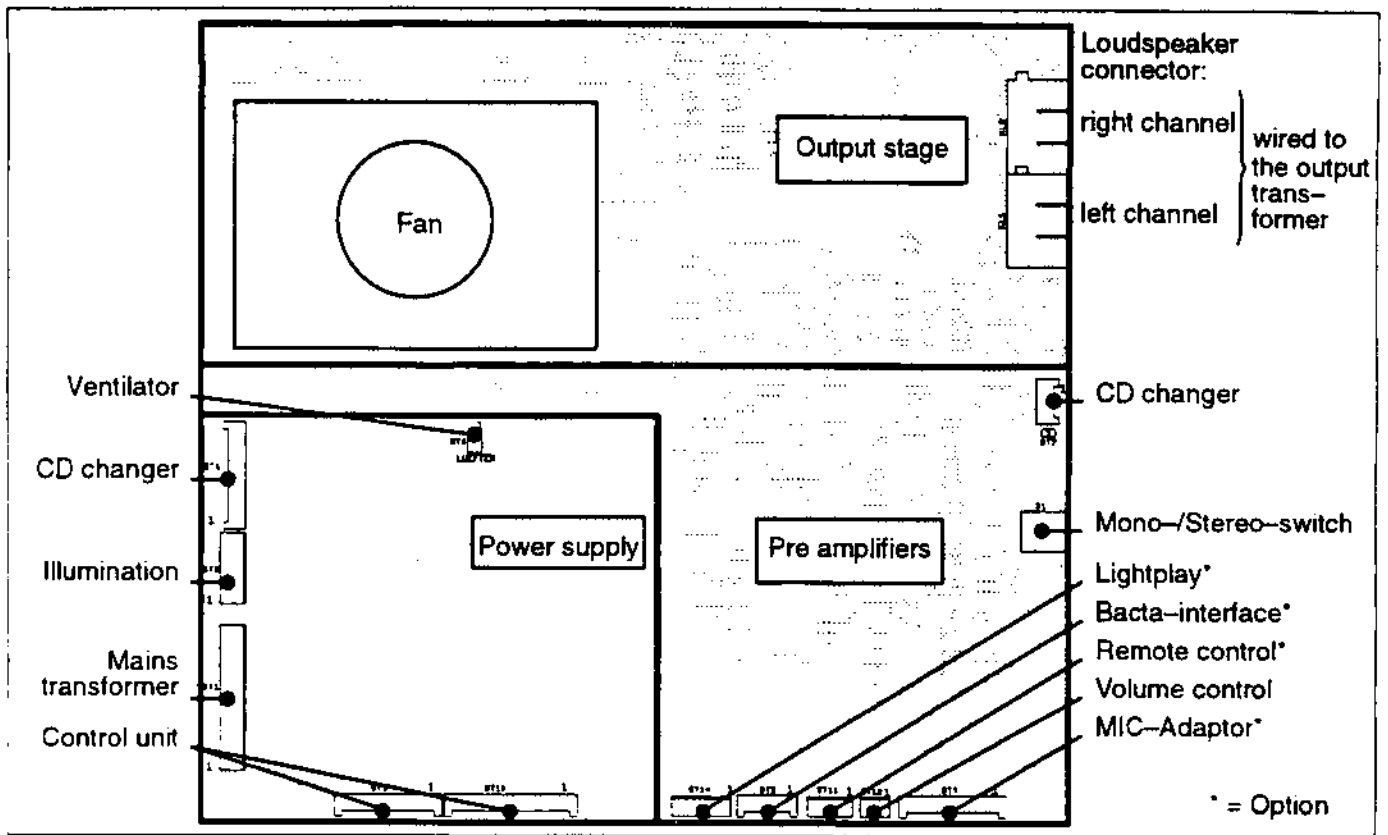

Figure 14: Structure of the circuit board Central Unit ES5.1

### 1.12.8. Control Unit

This PCB contains the microprocessor which controls all functions of the phonograph.

Evaluation is performed with the phonographs keyboard and display or with data transfer via the serial interface connector located on this PCB.

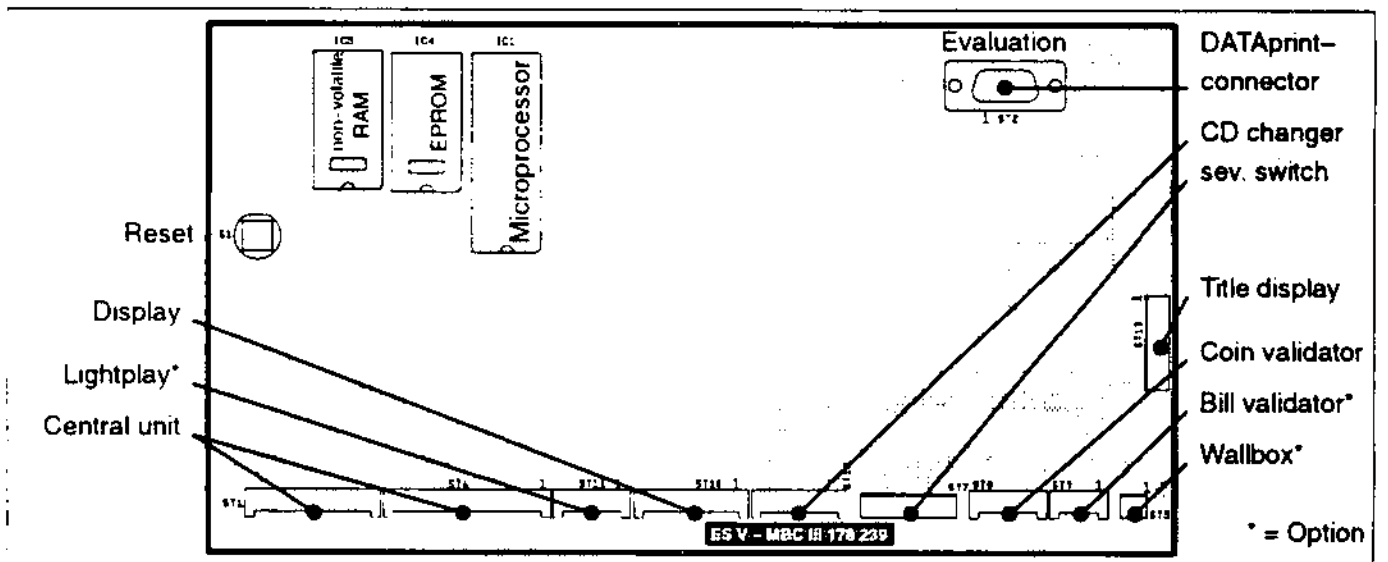

Figure 15: Structure of the Control Unit

### 1.12.9. Audio system

The audio system of this phonograph consists on the following main parts:

- CD player
- stereo amplifier
- output transformer
- cross over network with loudspeakers

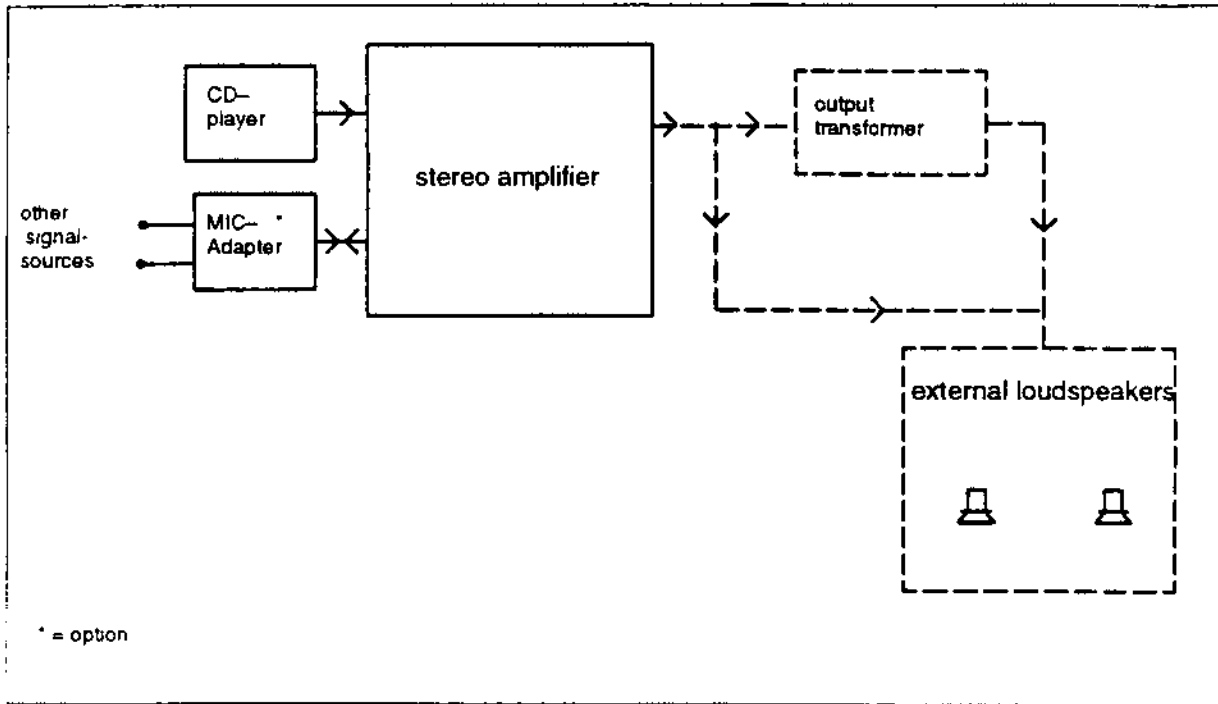

Figure 16: Structure of the main components of the audio system

### 1.13. Remote control

The phonograph can optionally be equipped with cable-type remote control or infrared remote control. All functions and the operation of both models are identical. Therefore, this description is valid for both of them.

The buttons "+" or "-" attached to the rear of the cabinet allow a common adjustment of volume for both channels. By pressing "REJECT" you can return the CD currently playing.

These three functional buttons attached to the phonograph correspond to the function of the buttons I+II, and REJECT on the remote control.

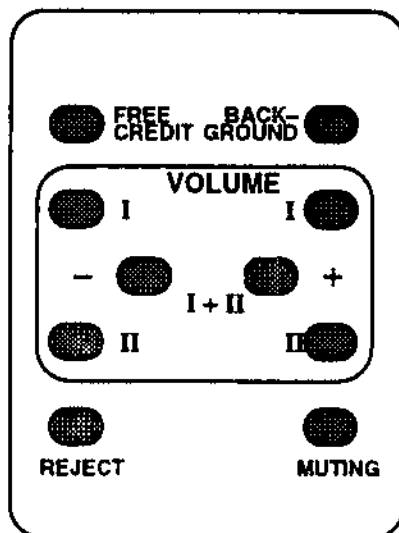

Figure 17: Remote control

#### 1.13.1. Setting the volumes

We differentiate between four volumes:

- 1 - the "normal volume" of selected titles, random play titles
- 2 - the "background volume" of titles to be played in background mode
- 3 - the "MIC volume" for microphone announcements, if the microphone is switched on
- 4 - the "tape volume" for reproduction of tape music

The keys have the following function:

- Keys "I" controlling the left channel (increase and decrease)
- Keys "II" controlling the right channel (increase and decrease)
- Keys "+" increase of volume of both channels.
- Keys "-" decrease of volume of both channels.

When pushing the center keys "I+II" (red) the channels are regulated together. If they were differently set, they are first "balanced" and regulated together.

When no selection is being made, the volume for the channels is shown on display 3 during the adjustment, in steps of "1" to "31".

While "Muting" is active the message "OFF" appears in display 1. No more titles will be played until "Muting" is cancelled by pressing "Muting" again.

The last volume setting is stored during "power off".

The maximum possible volume can be limited

- for normal volume by programming P051 in steps of "1" to "31"
- for background volume by programming P052 in steps of "1" to "31"
- for microphone volume by programming P055 in steps of "1" to "31" and
- for tape volume by programming P058 in steps of "1" to "31"

For P051, P052, P055 and P058 refer to programming section.

*Note:* To protect the amplifiers a check is made whether an overload occurs due to mismatching. Upon recognition of an error the volume of the corresponding channel is reduced step by step automatically by the control unit until a non-critical point is reached.

### 1.13.2. The key "MUTING"

The volume of both channels can be set to "off" by pressing the key "MUTING". The message "OFF" appears on display 1 in the operators console. Again pressing the key "MUTING" or pressing one of the "VOLUME +" keys causes the system to switch back to the previously set volume for both channels.

*Note: With display "OFF" no more CD's are played until "Muting" is cancelled.*

### 1.13.3. The key "FREE CREDITS"

Free credits can be called up by pressing the key "FREE CREDIT". The following free credits are possible depending upon the programming of P091–P095:

- Number of set free credits can be called up individually one by one
- Unlimited free credits can be called up individually one by one
- Permanent credit (free play) when pressing key "FREE CREDIT" for the first time (credit displays "99"). When key "FREE CREDIT" is pressed again, permanent credit is taken away.
- Permanent credit automatically within the time window

By using the program steps P091 to P093 a time window can be defined. While this time window is active free credits can be called up.

If no time window is defined of free credits can be called up at any time.

By setting the program step P095 you can define if free credits (1–99) are renewed automatically every day or weekly.

### 1.13.4. The key "BACKGROUND"

The background mode can be switched on by pressing the key "BACKGROUND". The lamp "Background playing" in the operators console is turned on. When pressing this key again, the background mode is switched off and the lamp is turned off.

The phonograph offers the possibility to program four (4) different time windows for each day.

In the background mode up to 4 times 20 "random" records are played as defined in P105 and P107.

The time at which background music is to be played can be set in P101 to P103.

If a CD is selected by the customer while background music is playing, this interrupts the background disc and the selected disc (title) is played at "normal volume".

## 1.14. Evaluation of the statistics

### 1.14.1. Read-out of statistical values using the internal service program

You should make a statistical evaluation of the phonograph at regular periods.

- "REJECT" a still playing CD
- Open the phonograph and pull out the service switch to enter the service mode.  
Display 3 automatically shows the least played CD with ranking e.g.: P010 \_\_1\_\_73
- Press key "C" to clear display. The display shows P\_\_\_\_\_.  
Enter the following program numbers for:
- **Read counters:**
  - P010 and H = Popularity (P010 least played, P011 most played titles)
  - P012 and H = Hitparade (Top 10 Hits)
  - P013 and H = Cash total
  - P014 and H = Counter for number of coins
  - P016 and H = Counter for plays
  - P017 and H = Number of selected titles
  - P018 and H = Number of selected albums
  - P019 and H = Number of overplay titles
  - P020 and H = Number of payed credits
  - P021 and H = Number of free credits provided
  - P022 and H = Number of background titles played
  - P023 and H = Number of autoplay titles
  - P024 and H = Number of advertisement titles
  - P025 and H = Number of Happy-Hour credits
  - P026 and H = Number of power-on hours of the phonograph

After you have read-out the statistical values of your interest you have the possibility to erase the corresponding counters, thus to start a new statistics period. While you are in the service mode

- Press key "C" to clear display. The display shows P\_\_\_\_\_.  
Enter the following program numbers for:
- **Erase counters:** P033, and selected code number:
  - 0 and H = delete all memory contents **Attention, all counters are erased!**
  - 1 and H = delete only hitparade (P012)
  - 2 and H = delete popularity only (P010)
  - 3 and H = delete all cash counters (P013 - 025)
  - 4 und H = delete credit memory only
  - 5 und H = delete selections only
  - 6 und H = delete error messages only

### 1.14.2. Data transfer and storage with DATAprint

You also have the possibility to make a printout of the statistical informations of the phonograph. Therefore you need the NSM DATAprint for statistic collecting / printing, which is connected to the evaluation socket on the control unit of the phonograph.

- "REJECT" a still playing CD
- Open the phonograph and pull out the service switch to enter the service mode.  
Display 3 automatically shows the least played CD with ranking e.g.: P010 \_\_1\_\_73
- Plug the printer connector into the 9 pin socket "EVALUATION" of the CB CONTROL UNIT.
- Press key "C" to clear display. The display shows P\_\_\_\_\_.  
Enter the following program numbers for:

Using a NSM DATAprint you can print out simple tables including statistical data (text mode) or graphically prepared statistical data (graphic mode).

To print out the statistics of the phonograph in "text mode" (Example: see figure 20)

- Enter 30H. the display shows P030 \_\_\_\_.
- Enter 0. Counters + Errors, as well as popularity are transferred into the DATAprint.

*Note:* After successfully transferring the statistical data to the DATAprint the statistical data is erased in the phonograph when you close the lid (door) or exit the service mode.

To print out the statistics of the phonograph in "graphic mode"

- Enter 31H. The display then shows P031 \_\_\_\_.
- Now enter the code for the desired printout:
- 0 = complete information
  - 1 = all cash counters
  - 2 = all counters
  - 3 = settings
  - 4 = popularity
  - 5 = hit parade of all titles of this location
  - 6 = last 20 error messages

*Note:* After finishing the graphical printout you must clear the statistical counters separately using P033, because they are not cleared automatically after closing the lid or exiting the service mode.

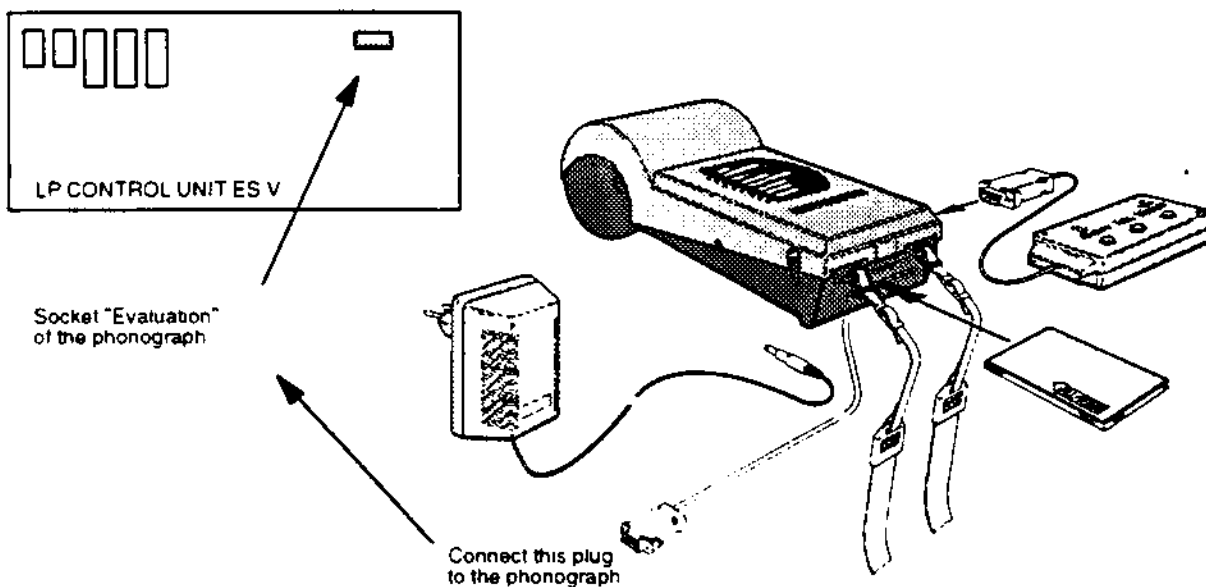

Figure 18: Evaluation unit NSM DATAprint

*Note:* If an error occurs during data transfer or if the printer does not start, "E0" appears on display 3. When a popularity counter has reached value 256, all popularity counters are divided by half. After dividing, the popularity printed out is relative. The number of divisions appears in the printout e.g.: "RELATIVE 5". This division is also made for the HITLIST.



```

08.02.94 / 09:46 V3.20
DATENSATZ: ..... 5

*NSM*
BOXES V ..... V.0107

BOX-ANALYSE:
BOX.NR. .... 0000
TIME ..... 15:06
DATE .....12.03.97

COUNTERS:
CASH ..... 87
PLAYS ..... 64
TITLE-SELECTIONS ..... 7
ALBUM-SELECTIONS ..... 0
OVERPLAYS ..... 0
FREE PLAYS ..... 8
BACKGROUND PLAYS ..... 49
AUTO PLAYS ..... 0
ADVERTISE PLAYS ..... 0
HAPPY HOUR CREDITS ..... 0
POWER-ON HOURS ..... 17

POPULARITY:
CD
001. 092. 085. 072 240. 005
006. 086. 096. 072. 080. 084
011. 141. 084. 066. 180. 085
016. 076. 001. 008. 100. 072
021. 005. 032. 193 002.
026. 072. 100. 060. 111
031. 061. 216. 061. 031. 007
036 004. 016. 038. 087

081 066 084 066 016 068
086 004 106 082 016 088
091 006 120 016 090 090
096 122 066 069 106 084

HITLIST:
RANK CD TRACK PLAYS
1 0101 7
2 5101 4
3 1701 2
4 3201 2
5 0601 2
6 0201 1
7 0301 1
8 0401 1
9 0501 1
10 0701 1

ERRORS
NO CODE * TIME DATE
NO ERRORS!

COLLECTIONS:
NO DATE TIME H/DAY
CURRENT COLLECTION
08 12 03 97 15 06 00
LAST COLLECTIONS
07 11 03 97 10 09
06 10 03 97 13 14
05 09 03 97 15 31
04 08 03 97 11 45
03 07 03 97 16 01

-END-
60751 BYTES FREI
    
```

indicates that this is the 5. data set in the DATAprint.

Version of the phonograph software.

**BOX-ANALYSE:** indicates to which phonograph this print-out belongs. Also date and time of printing are shown.

**COUNTERS:** shows the contents of the listed counters.

**POPULARITY:** shows the number of plays of each CD (5 CD's per row). Not played CD's have no entry. All 100 CD's are listed.

**HITLIST:** shows the TOP 10 of the hitlist of this phonograph. Format: Rank-CD-Track-Plays

**ERRORS:** shows the last 20 errors as CODE with argument # and with date and time. # = CD- / Title display position number.

**COLLECTIONS:** shows the current and the last 5 collections with date and time. H/DAY shows the average value of power-on hours per day.

**-END-** indicates the end of this printout. The following number shows the available storage capacity of the DATAprint 3000.

Figure 19: Sample printout in text mode, generated on DATAprint 3000

**BOX ES V** ..... V.0107  
**BOX-ANALYSE:**

BOX.NR. .... 0000  
 TIME ..... 15:06  
 DATE ..... 12.03.97

**COUNTERS:**

CASH ..... 0  
 PLAYS ..... 0  
 TITLE-SELECTIONS ..... 0  
 ALBUM-SELECTIONS ..... 0  
 OVERPLAYS ..... 0  
 FREE PLAYS ..... 8  
 BACKGROUND PLAYS ..... 49  
 AUTO PLAYS ..... 0  
 ADVERTISE PLAYS ..... 0  
 HAPPY HOUR CREDITS ..... 0  
 POWER-ON HOURS ..... 17

**BOX-STATUS:**

BOX-CODE ..... 0  
 CDS/TRACKS ..... 0024  
 STANS-BY-LIGHTINGS ..... 1105  
 ACTIVE LIGHTINGS ..... 1000  
 MAX.TIME/TRACK ..... 0  
 ORDER OF PLAY ..... 0  
 TRACKS IN A ROW ..... 0  
 CLR CREDIT ..... 2  
 CLR SELECTIONS ..... 2  
 MAX.VOLUME ..... 31  
 MAX.BGM-VOLUME ..... 16  
 MAX.MIC-VOLUME ..... 0

**PRICE SETTINGS:**

P6X	PRICE	P7X	VALUE
1	1 0100	1	100
2	1 0100	2	500
3	3 0200	3	200
4	3 0200	4	0
5	3 0200	5	0

ALBUM SETTING ..... 1  
 BILL BONUS ..... 0  
 MONEY CONVERSION ..... 0

**FREE CREDIT SETTINGS:**

START TIME ..... 00:00  
 STOP TIME ..... 00:00  
 ACTIVE ON DAYS ..... 0000000  
 FREE CREDITS ..... 200  
 RENEWAL PERIOD ..... 0

**BGM SETTINGS:**

START TIME ..... 00:00  
 STOP TIME ..... 00:00  
 ACTIVE ON DAYS ..... 0000000  
 LOCK FOR BGM ..... 0

**AUTO PLAY SETTINGS:**

START TIME ..... 00:00  
 STOP TIME ..... 00:00  
 ACTIVE ON DAYS ..... 0000000  
 AUTO PLAY PERIOD ..... 0

**ADVERTISEMENT SETTINGS:**

START TIME ..... 00:00  
 STOP TIME ..... 00:00  
 ACTIVE ON DAYS ..... 0000000  
 ADVERTISEMENT PERIOD ..... 0

**LOCK OUT SETTINGS:**

START TIME ..... 00:00  
 STOP TIME ..... 00:00  
 ACTIVE ON DAYS ..... 0000000  
 ACTIVATE LOCK ..... 0

**BOX-ANALYSE:**  
 indicates to which phonograph this print-out belongs. Also date and time of printing are shown.

**TITLE DISPLAY SETTINGS:**  
 show the actual settings of P180 to P187.

**COUNTERS:**  
 shows the contents of the listed counters.

**POPULARITY:**  
 shows the number of plays of each CD. Numbers >120 are not shown.

**BOX-STATUS:**  
 shows the actual setting of P041 to P052.

**PRICE SETTINGS:**  
 shows the actual setting of P061 to P077.

**HITLIST:**  
 shows the TOP 10 of the hitlist of this phonograph. Format: Rank-CD-Track-Plays

**ERRORS:**  
 shows the last 20 errors as CODE with argument # and with date and time # = CD- Title display position number

**COLLECTIONS:**  
 shows the current and the last 5 collections with date and time H:DAY shows the average value of power-on hours per day

**FREE CREDIT SETTINGS:**  
**BGM SETTINGS:**  
**AUTO PLAY SETTINGS:**  
**ADVERTISEMENT SETTINGS:**  
**LOCK OUT SETTINGS:**  
**HAPPY HOUR SETTINGS:**  
 show the actual settings of P091 to P144

**HAPPY HOUR SETTINGS:**

START TIME ..... 00:00  
 STOP TIME ..... 00:00  
 ACTIVE ON DAYS ..... 0000000  
 HAPPY HOUR BONUS ..... 0

**TITLE DISPLAY SETTINGS:**

START TIME ..... 00:00  
 STOP TIME ..... 00:00  
 ACTIVE ON DAYS ..... 0000000  
 TITLE DISPLAY PERIOD ..... 0  
 TITLE DISPLAY MODE ..... 0

**POPULARITY:**

CD:

CD	0	20	40	60	80	100	120
000							
001							
002							
003							
004							
005							
006							
007							
008							
009							
010							
011							
012							
013							
014							
015							
016							
017							
018							
019							
020							
021							
022							
023							
024							
025							
026							
027							
028							
029							
030							
031							
032							
033							
034							
035							
036							
037							
038							
039							
040							
041							
042							
043							
044							
045							
046							
047							
048							
049							
050							
051							
052							
053							
054							
055							
056							
057							
058							
059							
060							
061							
062							
063							
064							
065							
066							
067							
068							
069							
070							
071							
072							
073							
074							
075							
076							
077							
078							
079							
080							
081							
082							
083							
084							
085							
086							
087							
088							
089							
090							
091							
092							
093							
094							
095							
096							
097							
098							
099							
100							
101							
102							
103							
104							
105							
106							
107							
108							
109							
110							
111							
112							
113							
114							
115							
116							
117							
118							
119							
120							

**HITLIST:**

RANK CD TRACK PLAYS

1	0101	7
2	5101	4
3	1701	2
4	3201	2
5	0601	2
6	0201	1

**ERRORS:**  
 NO.CODE # TIME DATE

**COLLECTIONS:**

NO	DATE	TIME	H/DAY
CURRENT COLLECTION			
08	12.03.97	15:06	08
LAST COLLECTIONS			
07	11.03.97	10:09	
06	10.03.97	13:14	
05	09.03.97	15:31	
04	08.03.97	11:45	
03	07.03.97	16:01	

-END-  
 48153 BYTES FREI

Figure 20: Sample printout in graphic mode. generated with DATApriint 3000

### 1.15. Replacing and changing CD's

- "REJECT" a still playing CD either by pressing the REJECT-button on the rear of the phonograph or on the remote control.
- Open the phonograph and pull out the service switch to enter the service mode.  
Display 3 automatically shows the least played CD.
- By pressing key "1" repeatedly, each time the number of the next best CD is displayed.
- If necessary open the CD changer. Take out the left (CDs 0 to 50) or right (CDs 51 to 100) CD magazine.  
Pull out the selected CD trays of the CDs to be exchanged and change CDs.  
After changing a CD push back CD tray until it locks in.  
Close the changer after having changed the last CD.
- The title information of the new inserted CD's must be read into the phonograph by using program P161 (see programming section).
- Change corresponding title strips.  
Put the desired title strips and CD covers in corresponding position in the title display unit.

## 1.16. Connecting external loudspeakers in stereo mode

### 1.16.1. Connecting additional loudspeakers with same impedance

The connection wires of the external loudspeakers are led through the opening in the rear side of the cabinet to the inside and then to the connection terminals of the output stage.

**The polarity ▼ must be maintained because otherwise bass reproduction would nullify itself!**

The stereo amplifier of this phonograph provides an output of 200 Watt music power at 4 Ω per channel (= 125 Watt RMS). The impedance of the internal loudspeakers is 8 Ω, therefore they will use 100 Watt music power from the amplifier, only half of the available power.

In that case, the additional loudspeakers you may connect (refer to figure 21) cannot have an impedance of less than 8 Ω. Otherwise the amplifier would be "mismatched" and the overload protection would operate.

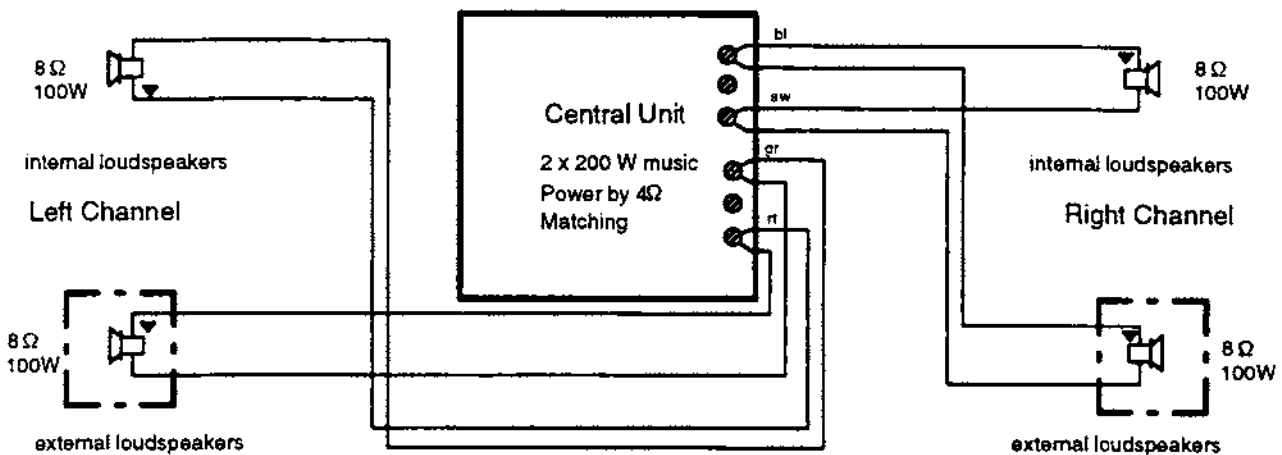

Figure 21: Stereo mode with normally connected loudspeakers

### 1.16.2. Connecting additional loudspeakers of higher impedance

If loudspeakers of a higher impedance are connected (refer to figure 22), a number of speakers can be connected parallel to the internal loudspeakers. In that case, a loudspeaker of a higher impedance would naturally be lower in volume.

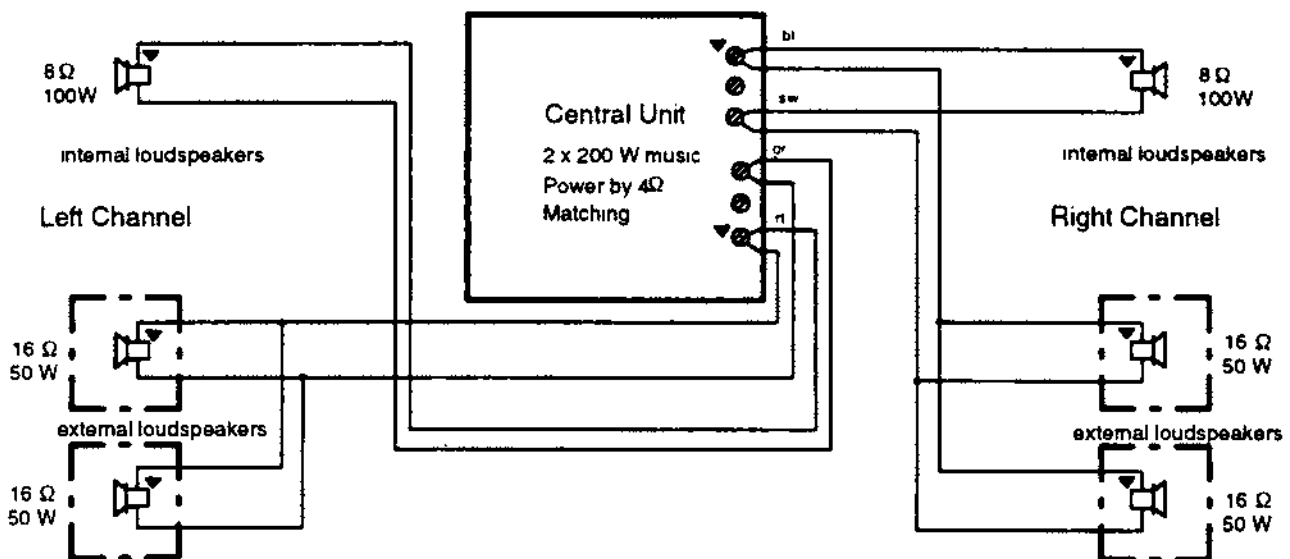

Figure 22: Stereo mode with connected loudspeakers of high impedance

## 1.17. Connecting external loudspeakers in mono mode

### 1.17.1. Sound system for separate rooms

If the volume is to be controlled independently for 2 rooms, the loudspeakers of the first room can be connected to one channel. The loudspeakers for the other room can then be connected to the second channel (refer to figure 23). The switch S1 "Mono/Stereo" located on the PCB "Central Unit" has to be switched to "MONO" (refer to **Location of the mode switch**). For this independent procedure a volume control with separate controls is necessary (refer to **Remote control operation**).

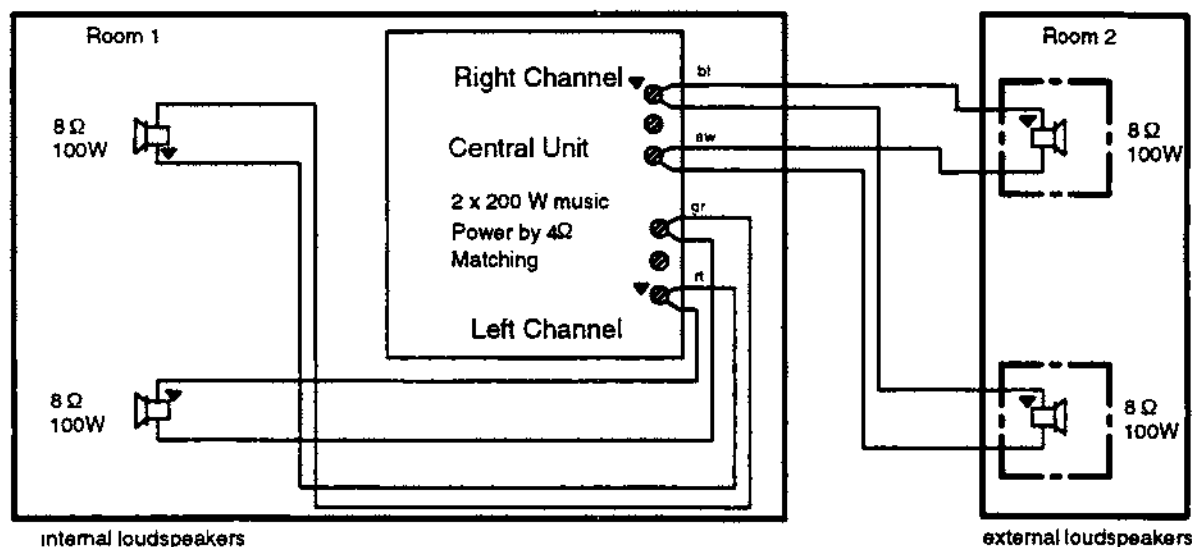

Figure 23: Mono mode with connected loudspeakers for seperated rooms

### 1.17.2. Mono mode with serial connected loudspeakers in one room

Take care that the total impedance of connected loudspeakers does not become less than 4 Ω. If you connect more loudspeakers in one room. It may be necessary to connect them in series or parallel. Series connected loudspeakers have less volume.

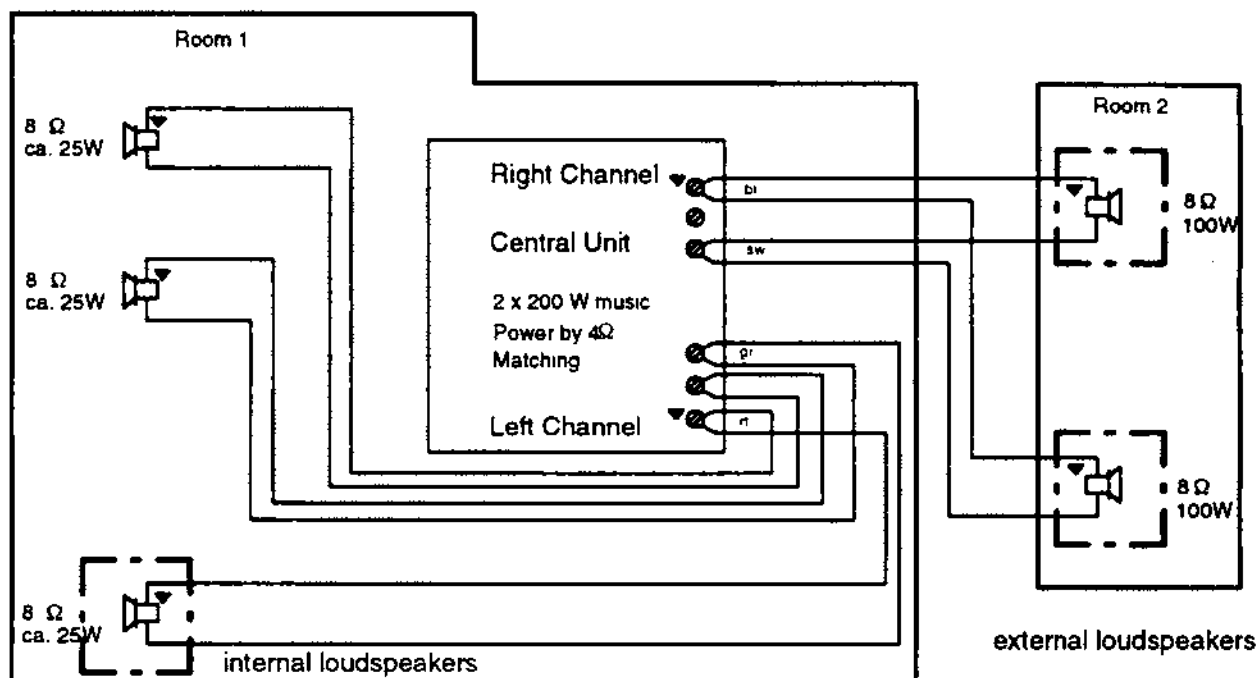

Figure 24: Mono mode with serial connected loudspeakers in one room

### 1.18. Location of the stereo / mono switch

NSM phonographs can be operated in different modes: stereo, mono or S-Stereo.  
S-stereo simulates a base wide sound system for better stereo sound effects.

The mode switch S1 used for this purpose is placed on the CB CENTRALEINHEIT ES 5.1.

Just move the switch into the desired position.

The factory setting of the mode switch is "STEREO".

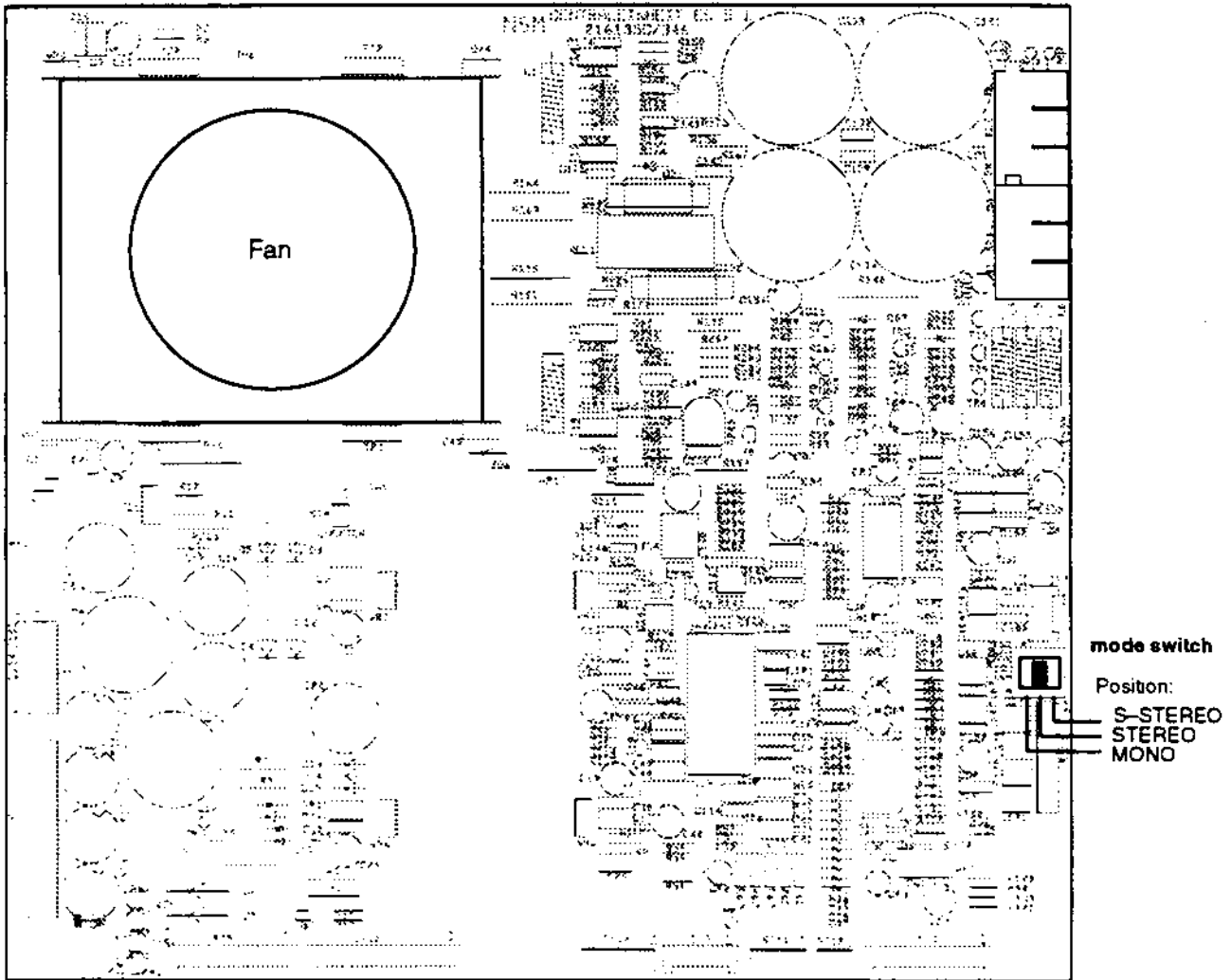

Figure 25: The mode switch S1 placed on the CB "CENTRAL UNIT ES 5.1"

### 1.18.1. Check that the phonograph is not overloaded

To avoid distortion of sound or destruction of equipment you should perform the following steps after changing any loudspeaker connection.

- A. Make sure that the internal and the external loudspeakers are connected to the proper connectors. Then power on the phonograph.
- B. Set the phonograph's volume to full power (display = 31) and make a selection.
- C. While the music is playing no overload distortion or interruption should occur. The volume should not be decreased automatically from its maximum 31, shown on the display. If any distortion or interruption occurs or if the volume is decreased, the amplifier is overloaded. Then you have to perform step D.
- D. Perform this step only if any distortion or interruption occurs. Turn off the phonograph. Find and correct the reason for this overload: perhaps there is a short circuit on a loudspeaker or too many loudspeakers are connected. Then repeat step A–C.

**Attention:** When playing a test-CD, the description that comes with the test-CD should be followed exactly. However, do not give sine signals with peak signal "0dB" at full volume level to the loudspeakers for more than 1 sec. Other unfiltered noises and high-frequency signals (which are only used for measuring purposes) can also damage the amplifier and loudspeakers at full volume. When checking channel separation, it has to be verified that the box is not switched to "Mono-mode" (refer to →Mono mode operation).

### 1.19. Adjustments for better sound quality

#### How to get the best sound:

Using the service program (command **P054**) you can adjust the phonograph's sound settings for different kinds of room acoustics via the keyboard. Here treble and bass are set for both channels at the same time. The changed setting is immediately heard and stored in P054.

#### Key pad layout for sound setting:

▲ more bass 1	▲ more bass + treble 2	▲ more treble 3
4 mean value	5 mean values	6 mean value
▼ less bass 7	▼ less bass + treble 8	▼ less treble 9
C Cancel	0	H Step to the next com- mand.

Example for moderately-absorbent rooms:

Enter: P 054 H

Change per pressing keys  
i.e. Key "8" = less bass and treble



standard value of bass, treble

Example for non-absorbent rooms

Enter: P 054 H

Change per pressing keys  
i.e. more bass and less treble



value of bass, treble



## 1.20. Output transformer

If you want to connect more external loudspeakers to the phonograph so that the total impedance will be less than 4  $\Omega$ , you have to connect the output transformer in order to avoid destruction of the output stage or distortions. See also the diagram "Loudspeaker Connection" at the end of this chapter.

### 1.20.1. Extension Loudspeaker Operation

To avoid a poor sounding phonograph, take care when adding extension loudspeakers. Regard the following requirements:

- 1.) Loudspeakers must be wired so that the power consumed by the phonograph loudspeakers and the extension loudspeakers (including remote selectors) does not exceed the amplifier power rating.
- 2.) Extension loudspeakers should produce the desired sound level relative to the sound level of the loudspeakers of the phonograph.
- 3.) All loudspeakers must be connected with the correct polarity.

Several tables have been included to assist you with connecting the extension loudspeakers. The diagram at the end of this chapter shows the entire sound system.

#### Low Impedance Loudspeakers

##### 4 $\Omega$ -loudspeakers

No more than one 4  $\Omega$ -loudspeaker should be connected to one loudspeaker line. If several 4  $\Omega$ -loudspeakers are to be used, each loudspeaker should have its own line.

##### 8 $\Omega$ -loudspeakers

Low impedance loudspeakers with 8  $\Omega$  can be used if the connecting cable is less than 100 feet long. The loss on 100 feet of connecting cable (type: AWG 18/0,75 mm<sup>2</sup>) feeding one 8  $\Omega$ -loudspeaker is 15 %. The loss for two 8  $\Omega$ -loudspeakers is 30 %.

**Do not connect a low impedance loudspeaker to a loudspeaker tap that exceeds the loudspeaker's power rating.**

##### 70 V-loudspeakers

To avoid possible cable losses on long loudspeaker lines, 70 V-loudspeakers can be used. The power level in the 70 V-loudspeakers is set at each loudspeaker with its internal transformer.

#### **CAUTION:**

In any loudspeaker installation, the sum of the power ratings of all loudspeakers must not exceed 250 W RMS (sine wave power, 125 W RMS per channel).

Music power: Often there are two values given as technical data of loudspeakers:

Besides the sine wave power (RMS) also the allowable peak load (music power) is given.

The music power can be calculated as follows:

Multiplying the sine wave power by the value 1.6 results in the value of the music power (e.g. 125W RMS x 1.6 = 200W music power).

## 1.20.2. Selecting loudspeaker power

### General Instructions

This section will lead you through the power and loudspeaker selection process. This process consists of three major steps and several smaller steps. The major steps are:

- 1.) Identifying the extension loudspeakers and calculating their external loudspeakers power.
- 2.) Making the external loudspeaker connections.
- 3.) Determining and selecting the phonograph power.

## 1.20.3. Definition of extension loudspeakers and their power consumption

- 1) Use a pencil (you may want to revise your entries) to write data to the work sheets on the following pages.

Use table 3 to calculate the amount of power consumed by the extension loudspeakers.

- 2) Note the quantity of 4  $\Omega$ –loudspeakers in the space of the column "Quantity".  
**Enter stereo loudspeakers as two speakers.**  
Multiply the quantity with the power consumption.

Write your results at the space **4 $\Omega$  – loudspeakers Total = —W**".

- 3) Perform the same procedure for 8  $\Omega$ –loudspeakers  
and then for 70 V–loudspeakers.  
  
= —W".

Table 3: Calculation of the loudspeaker's power

<u>4 Ω-stereo-loudspeakers</u>		*) values given in W RMS		
	Quantity	Power consumption	Connecting taps	
loudspeaker for 1,0*) W:	___ each 1,0 W	= ___ W	(E1 and E2)	
loudspeaker for 4*) W:	___ each 4 W	= ___ W	(E1 and E3)	
loudspeaker for 16*) W:	___ each 16 W	= ___ W	(E1 and E4)	
loudspeaker for 28*) W:	___ each 28 W	= ___ W	(E1 and E5)	
loudspeaker for 62*) W:	___ each 62 W	= ___ W	(E1 and E6)	
loudspeaker for 125*) W:	___ each 125 W	= ___ W	(E1 and E7)	
<b>4 Ω-loudspeaker</b>	<b>Total</b>	<b>= ___ W</b>		
<u>8 Ω-stereo-loudspeakers</u>				
	Quantity	Power consumption	Connecting taps	
loudspeaker for 0,5*) W:	___ each 0,5 W	= ___ W	(E1 and E2)	
loudspeaker for 2*) W:	___ each 2 W	= ___ W	(E1 and E3)	
loudspeaker for 8*) W:	___ each 8 W	= ___ W	(E1 and E4)	
loudspeaker for 14*) W:	___ each 14 W	= ___ W	(E1 and E5)	
loudspeaker for 30*) W:	___ each 30 W	= ___ W	(E1 and E6)	
loudspeaker for 62*) W:	___ each 62 W	= ___ W	(E1 and E7)	
<b>8 Ω-loudspeaker</b>	<b>Total</b>	<b>= ___ W</b>		
<u>70 V-loudspeakers</u>				
The variable power selection for 70 V-loudspeakers is performed at the corresponding transformer integrated in each speakers cabinet.				
Add the power consumption of all 70 V-loudspeakers and note this total value:				
<b>70 V-loudspeaker</b>	<b>Total</b>	<b>= ___ W</b>	<b>(A1 and A2)</b>	

4) After you have calculated all the necessary values you have to add them to get the

**Total power consumption of external loudspeakers:**

Total power consumption of 4 Ω-loudspeakers \_\_\_\_\_ W

Total power consumption of 8 Ω-loudspeakers \_\_\_\_\_ W

Total power consumption of 70 V-loudspeakers \_\_\_\_\_ W

**Total power consumption of all external loudspeakers \_\_\_\_\_ W in STEREO.**

Now this is the necessary power consumption which the amplifier of the phonograph at least must supply for external loudspeakers. This value must be less than the maximum power consumption of 250 W RMS (400 W music power). If it is more then 250 W RMS you have to reduce the number of connected loudspeakers. Afterwards calculate it once more.

- 5) Subtract this total power consumption for external loudspeakers from the maximum power consumption of the phonograph 250 W RMS (400 W music power) and note the result at the end of the following line:

**Available power for the phonographs internal loudspeakers: \_\_\_\_\_ W in STEREO.**

Remember: After subtraction of the total power from 250 W RMS you will get the "Available power for the phonographs internal loudspeakers". Make sure to note this value. You will need this value later, after you have connected all of the external loudspeakers, to calculate the connection of the internal loudspeakers.

**NOTE:**

The amplifier may be rated up to 250 W RMS before the delimitation will start.

1.21. Connection diagram for output transformer

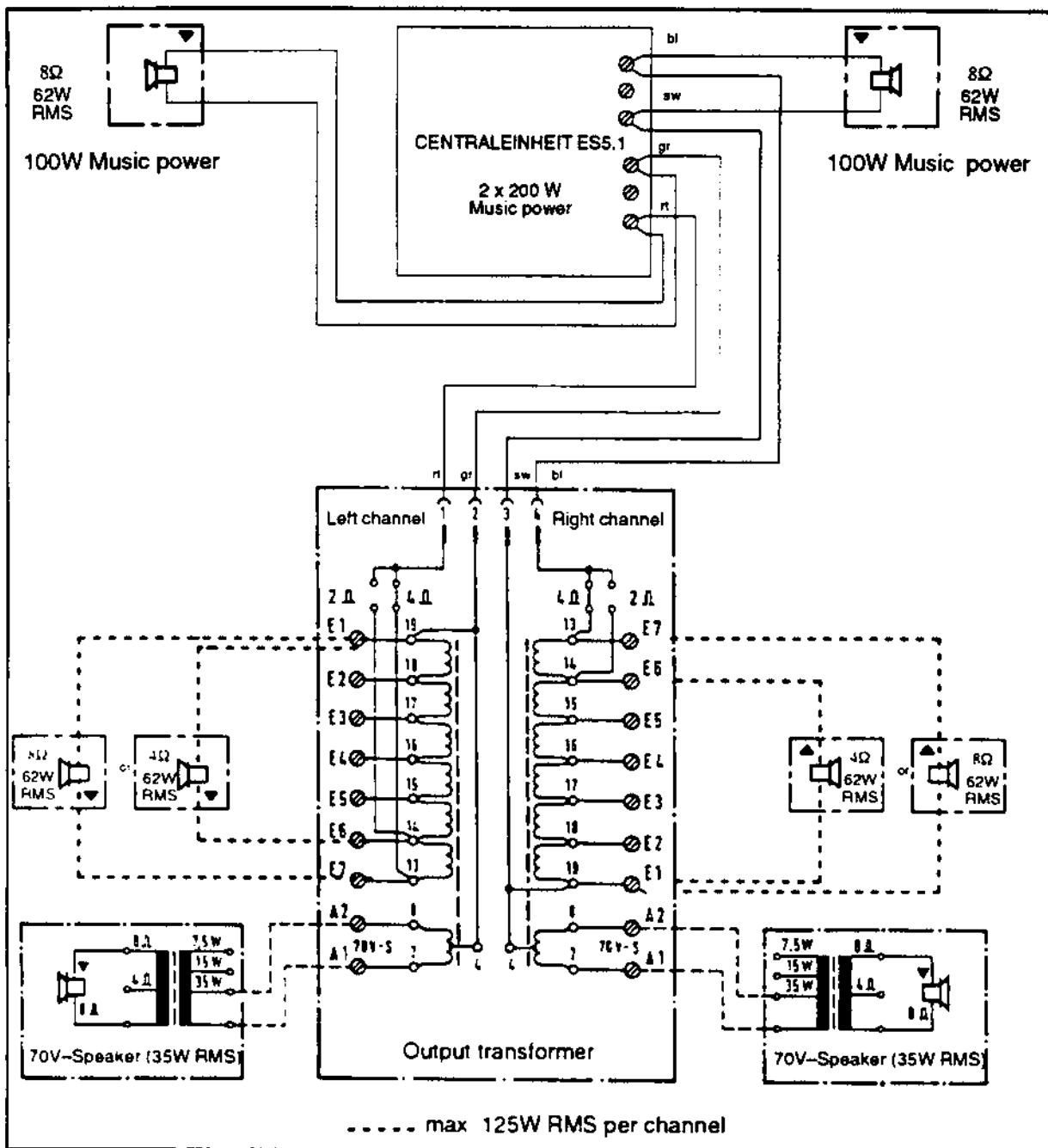

Connection of 70 V-loudspeakers  
max. 60 W RMS

Terminal Position	Loudspeaker impedance				
	1 Ω	2 Ω	4 Ω	8 Ω	16 Ω
E1-E2	4W RMS	2W RMS	1W RMS	0.5W RMS	0.3W RMS
E1-E3	16W RMS	8W RMS	4W RMS	2W RMS	1W RMS
E1-E4	64W RMS	32W RMS	16W RMS	8W RMS	4W RMS
E1-E5	125W RMS	62W RMS	28W RMS	14W RMS	8W RMS
E1-E6	-	125W RMS	62W RMS	30W RMS	16W RMS
E1-E7	-	-	125W RMS	62W RMS	30W RMS

**Mono**

**Stereo**

Figure 26: Connection diagram for external loudspeakers and output transformer

## 1.22. Adjusting the volume of additional loudspeakers using a "L-CONTROL"

If the volume of external loudspeakers should be controlled without changing the load of the amplifier, this can be performed using a volume controller (called L-CONTROL). The maximum volume is set at the phonograph's amplifier.

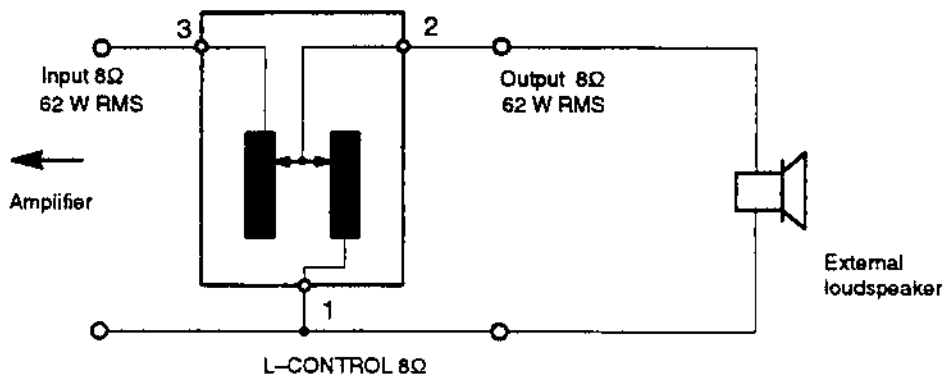

Figure 27: L-CONTROL, principle of function

**Attention:** The input impedance of this circuit is 8Ω independent of the position of the L-CONTROL. The phonograph's amplifier is always driven with a defined load. The power of the amplifier is distributed to the L-CONTROL and connected loudspeakers. In position 0 volume the L-CONTROL takes the whole power and in position max. volume the loudspeakers takes the whole power of the amplifier. So take care that both, the L-CONTROL and the loudspeakers are rated for the maximum power of the amplifier.

If a slight mutual influence on the volume adjustment is taken into bargain, the output transformer can be omitted when power is low by serially connecting two volume controllers:

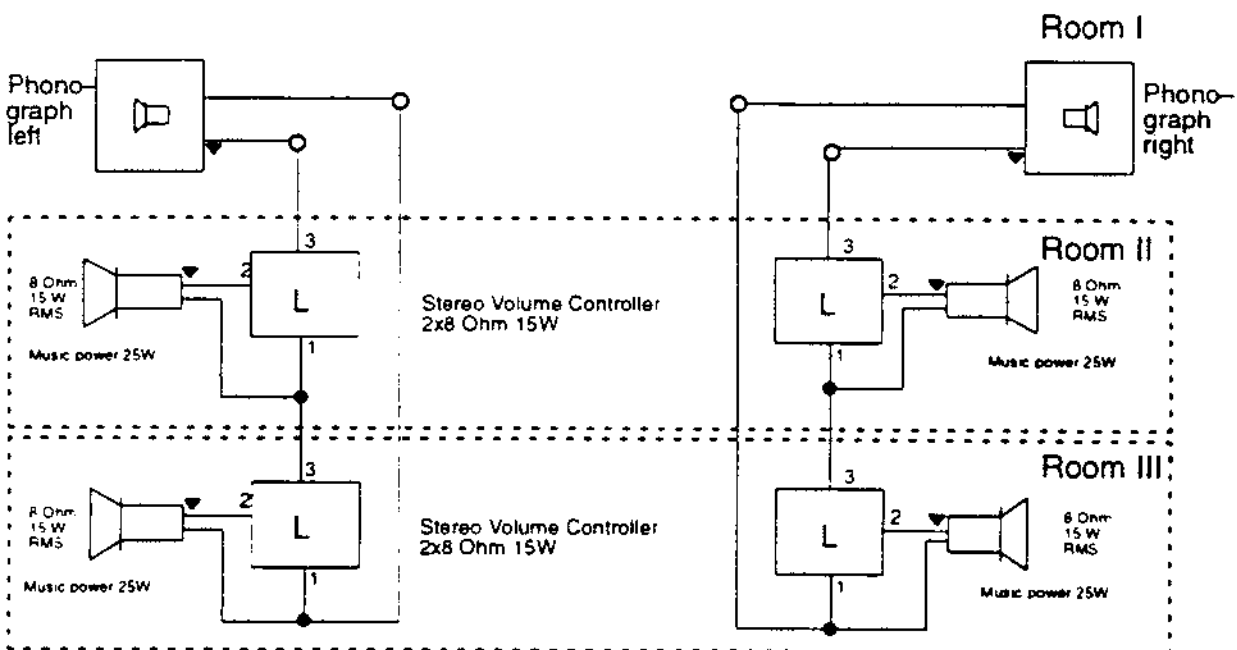

Figure 28: L-CONTROL, example of connecting

### 1.22.1. Independent control of more loudspeakers using L-CONTROL

Set the volume of the phonograph to its maximum level used every time.

The volume of additionally connected loudspeaker is then controlled independently via the separated L-CONTROL of each room. The output transformer becomes necessary because of the total impedance of the whole system, which amounts to 2.7Ω.

Separate volume adjustment with volume controllers via output transformer

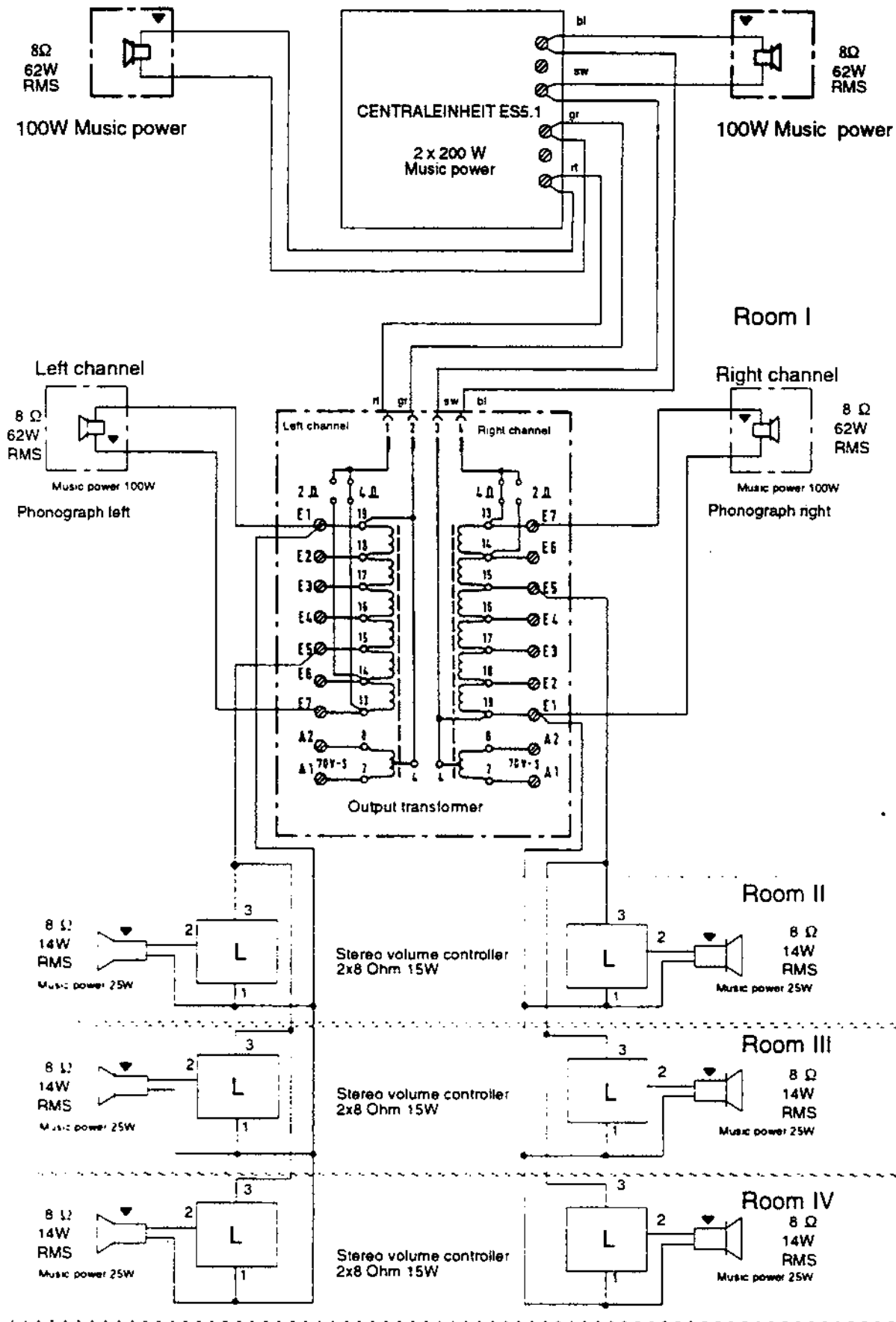

Figure 29: Volume controller with output transformer

# Section 2



## 2. Section

### 2.1. Programming of special and individual settings

### 2.2. General information, programming overview

In order to program NSM phonographs in a simple yet extensive fashion, a service program has been installed with which the different settings can be altered via the keyboard of the phonograph.

In order to get into the service mode you have to perform the following steps:

- open the front door of the cabinet
- pull out the service switch (cabinet interlock switch)

By changing the display, the phonograph indicates that it is in service mode now. The display shows the following information:

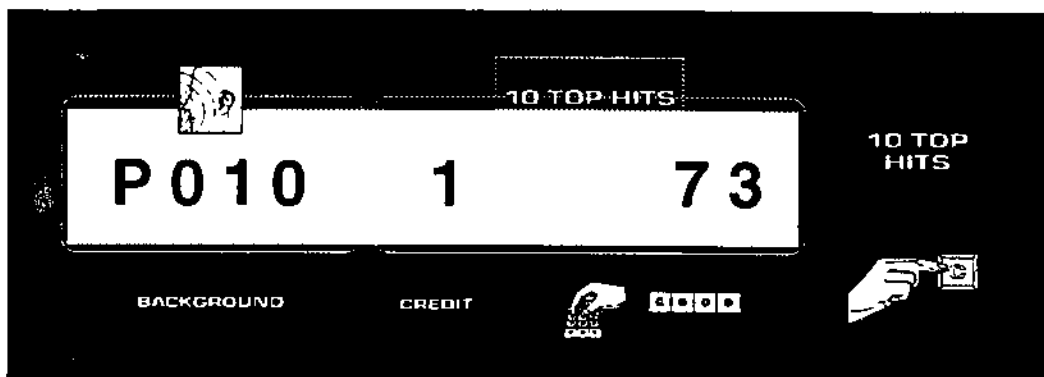

Figure 30: Display after entering the service mode

The display shows P010 and values concerning the popularity of the least played CD.

For example.



After pressing the key "C" the display is changed. To the left the letter "P" appears.



Now enter the desired program number. Zeros before the number can be left out. A program called up in error can be cancelled by pressing "C". Pressing "H" confirms the entry.

For example

*Enter: P 40 H 1 H*  
to program the phonograph  
with all default values.



In order to find single programs more easily, all possible programs are put together in groups.

## 2.3. Table of commands in program version 4.07

P001	<b>Authorization: Enter authorization code:</b>	"PPPP"
P002*	<b>Change authorization code</b>	"PPPP"
P003	<b>Show version number: CCU</b>	1: Eprom MBC 2: Laser
	<b>Statistics:</b>	
P010	0: Number of least played CD 1: Number of second-least played CD 2: Number of plays 3: Data about any CD	
P011	0: Number of the most-played (best) CD 1: Number of the second-best CD 2: Number of plays 3: Data about any CD	
P012	0: Top-title, hit #1; 2: number of plays 1: Second-best title	
P013*	0: Cash amount since last evaluation 1: Accumulated cashbox amount	
P014*	0: Number of coins through Chute 1 (K1) 1: Number of coins through Chute 2 (K2) 2: Number of coins through Chute 3 (K3) 3: Number of coins through K4 or bills into NP1 4: Number of bills into validator NP2 5: Accumulated (Acc.) counter for K1 6: Acc. counter for K2 7: Acc. counter for K3 8: Acc. counter for K4 or NP1 9: Acc. counter for K5 or NP2	
P016*	0: Counter of played titles	1: Acc. counter
P017*	0: Counter of selected titles	1: Acc. counter
P018*	0: Counter of album selections	1: Acc. counter
P019*	0: Counter of overlay titles	1: Acc. counter
P020*	0: Counter of paid credits	1: Acc. counter
P021*	0: Counter for free credits	1: Acc. counter
P022*	0: Counter for background titles	1: Acc. counter
P023*	0: Counter for autoplay titles	1: Acc. counter
P024*	0: Counter for advertising tracks	1: Acc. counter
P025*	0: Counter Happy-Hour-credits	1: Acc. counter
P026*	0: Counter for Power-on hours	1: Acc. counter
P028	Number of unused credits	
P029	Number of selections not yet played	
P030	<b>Data transfer to DATAprint in text mode</b> 0: cashbox, counters, hitparade, errors 1: only the hitparade	
P031*	<b>Data transfer to DATAprint in graphic mode</b> 0: all available data 1: Cashbox 2: Counter and cashbox contents 3: General settings 4: Popularity of all CDs 5: Top all hits 6: Previous 20 error reports	
P032	Option not used for USA	
P033*	<b>Cancellation routines:</b> 0+H: clear all memory entries' 1+H: clear hit parade' 2+H: clear popularity' 3+H: clear counters and cashbox contents' 4+H: clear credits' 5+H: clear selection memory' 6+H: clear error memory'	

Additional program steps—>

		Standard	Individual	see page
	<b>General settings:</b>			
P040*	0+H Default values for 41 to 54 & 94 1+H Default values for 41 to 54 & 94 & 114, 117			13
P041*	Define machine #, max. 4 digits	0		13
P042	Selection limit for CD/track (title) max. 100 CDs, 99 tracks	0032		14
P043	Light show in stand-by, if installed	1105		
P044	Light show in operation, if installed	1000		
P045*	Time limit for playing of tracks in minutes (0=no limit)	0		14
P046	Sequence of playing normal selected tracks (0= fofo; 1=numerical; 2= random)	0		14
P047	Maximum number of titles in a sequence from one CD (0 = no limit)	0		14
P049*	Cancels credits after power off / stand-by (x=0=no, X=1 to 240=yes) x/10 hrs.	2		15
P050*	Cancels selection memory after power off (no: x=0, yes: x=1 to 240) x/10 hrs.	2		15
P051*	Maximum volume in play operation (max. 31)	31		16
P052*	Maximum volume for background music (0=normal; 1-31= separated volume)	16		16
P053	Sound system setting set volume	0505		16
P054	Sound system setting set treble and bass	0808		17
P055*	maximum volume for MIC 0: normal; 1-31 separated volume	0		17
P056	Display hitparade on console display 0: no; 1: after 16s with credit; 2: without credit	2		17
P057	Clear selection memory with remote control 0: no; 1, yes	0		17
P058*	maximum volume for tape 0: normal; 1-31 separated volume	0		17
	<b>Price settings:</b> see table "Price settings"			18
P060*	0+H Cancels previous setting n+H Selection "n" from table (s.a.)			18
P061*	Arbitrary price setting for chute 1 xx=selections, yyyy=price	"xx yyyy" 0		19
P062*	same for chute 2	0		19
P063*	same for chute 3	0		19
P064*	same for chute 4	0		19
P065*	same for chute 5	0		19
P066*	Bonus listing for album setting 0 No album selection allowed 1 No bonus 2 1 bonus for 5 titles 3 1 bonus for 4 titles 4 1 bonus for 3 titles	1		19
	<b>Monetary value settings:</b> see table "Monetary value settings"			21
P070*	0+H Cancels previous monetary value n+H Selection "n" from table			19
P071*	Arbitrary monetary value setting for chute 1 zzzz=coin value (e.g. 0500=\$ 5 -)	"zzzz" 0		20
P072*	same for chute 2	0		20
P073*	same for chute 3	0		20
P074*	same for chute 4	0		20
P075*	same for chute 5	0		20
P076*	Bonus credits for bill insert	0		20
P077*	0 indirect revaluation 1 direct revaluation of inserted money	0		20
P078*	0 Display monetary value /100 1 Display monetary value /10	0		20
P080*	<b>Programming real time clock:</b> Set time	"ddmmyy"		22
P081*	Set date	"ddmmyy"		22
P082*	Set week-day (D=1 to 7)	"D"		23

		Standard	Individual	see page
P090*	<b>Programming free credits:</b> 0+H: default values			24
P091*	Start time of time window "Free Credit"	00:00		24
P092*	Stop time of time window "Free Credit"	00:00		24
P093*	Active on week-days "D" (D = 1 to 7) *) see footnote yes: 1+H; no: 0+H after day code display	0		24
P094*	Number of free credits: Enter: nnn+H 0: no free credit <200: No. of free credits individually used =200: unlimited use =201: Switch between no/unlimited use =202: automatically unlimited use	0		25
P095	Rebuild number of free credits: 0: no rebuild 1: rebuild daily; 2: rebuild weekly	0		25
P100*	<b>Backgroundmusic:</b> 0+H: default values Cancels entries for selected time window (1 to 4)			26
P101*	Start time for time window "Background music" enter 4 time windows in maximum or skip by pressing H	00:00		26
P102*	Stop time for time window "Background music" enter 4 time windows in maximum or skip by pressing H	00:00		26
P103*	Active on week-days "D" (D= 1 to 7) Enter 1234+H after day code [ ex. 1_1234 = monday (1) active for all time windows or 3_24 = wednesday active only for 2. and 4. time window]	0		26
P104*	Lock for background music (BGM): Enter: n+H 0: No background music 1: BGM possible in time window 2: BGM automatically in time window enter for 4 time windows in maximum or skip by pressing H	0		26
P105*	Enter 20 titles or CDs for each progr. time window Enter: (nnnn+H)	0		27
P106*	Patron selection (0=free, 1=locked for guests) enter for 4 time windows in maximum or skip by pressing H	0		27
P107*	Sequence of play (0=FIFO, 1=RANDOM) enter for 4 time windows in maximum or skip by pressing H	0		27
P108*	Paid for background music Enter: nn+H (0= no credit)	0		27
P110*	<b>Programming auto play:</b> 0+H: default values; cancels entnes+time			28
P111*	Start time for time window "Auto Play"	00:00		28
P112*	Stop time for time window "Auto Play"	00:00		28
P113*	Active on week-days "D" (D= 1 to 7) yes: 1+H; no: 0+H after day code	0		28
P114*	Time between two titles in minutes Enter: nn+H (0=no auto play)	15		28
P115*	Enter 20 titles or CDs Enter: nnnn+H	0		29
P116*	Patron Selection (0=free 1=locked for guests)	0		29
P117*	Sequence of play (0=FIFO, 1=RANDOM)	1		29
P120*	<b>Programming of advertisement play:</b> 0+H default values			30
P121*	Start time for time window "Advertisement"	00:00		30
P122*	Stop time for time window "Advertisement"	00:00		30
P123*	Active on week-days "D" (D= 1 to 7) yes: 1+H; no: 0+H after day code	0		30
P124*	Time between two titles in minutes Enter: nn+H (0=no adverts)	0		30
P125*	Enter 20 titles or CDs Enter: nnn+H	0		31
P126*	Patron Selection (0= free 1= locked for guests)	0		31
P127*	Sequence of play (0=FIFO, 1=RANDOM)	0		31
P130*	<b>Programming of lock-outs:</b> 0+H default values Cancels entries for selected time window (1 to 4)			32
P131*	Start time for time window "lock-out" enter 4 time windows in maximum or skip by pressing H	00:00		32
P132*	Stop time for time window "lock-out" enter 4 time windows in maximum or skip by pressing H	00:00		32
P133*	Active on week-days "D" (D= 1 to 7) Enter 1234+H after day code [ ex. 1_1234 = monday (1) active for all time windows or 3_24 = wednesday active only for 2 and 4 time window]	0		32
P134*	Activate/deactivate lock-out titles Enter: n+H 0: Title free; 1: Title locked in time window enter for 4 time windows in maximum or skip by pressing H	0		32
P135*	Enter 20 titles or CDs for each progr. time window Enter: nnnn+H	0		33

\*) Day code "D" means: 1 = Monday, 2 = Tuesday, 3 = Wednesday, 4 = Thursday, 5 = Friday, 6 = Saturday, 7 = Sunday

		standard	Individual	see page
P140*	Programming Happy-Hour-credits:0+H: default values,no Happy H.			34
P141*	Start time for time window "Happy Hour"	00:00		34
P142*	Stoptime for time window "Happy-Hour"	00:00		34
P143*	Active on week-ends "D" (D = 1 to 7) yes: 1+H; no: 0+H after day code display	0		34
P144*	Calculation number (n=1 to 5) 0=no Happy Hour	Enter: n+H 0		34
P150	<b>Calling up Test programs:</b> 0: Last reported error 1: Previous error report 2: CD# at which the error occurred 3: Time of occurrence 4: Date of occurrence			
P151 to p159 are reserved for the service staff. See Service manual				
<b>Title memory:</b>				
P160	0: read in all CD titles. i.e. with initial equipping of all CD's			
P161	Read in all titles of one newly equipped CD. Enter CD# "nn+H"			
P162	Read the title memory: 0: Number of titles from first CD 1: Number of titles from the next CD 2: Number of titles from the last CD 3: Number of titles from any CD Enter CD# "nn" +H			
P163	<b> Cancels title memory of all CD's</b> 0+H all entres set to 1			
P164	<b>Switching signal sources:</b> (This is only necessary when servicing) 0+H Mute (no signal source) 1+H CD-player 2+H Tape or cassette player 3+H microphone			
		standard	Individual	see page
P170*	Switching evaluation protocol (only GB) 0+H no protokol of this evaluation 1+H BACTA-protokol (England) 2+H DCL-protokol (England) (DCL = Data Carndge Loader) 3+H Data info at COM-Port with 1200 baud 4+H Data info at COM-Port with 2400 baud 5+H Data info at COM-Port with 9600 baud without delay 6+H Data info at COM-Port with 19200 baud without delay	1		39
The following program steps are not valid for the 3x18 title display				
P180*	Programming title display: 0+H Previous setting P181 to P187			40
P181*	Start time for time window "title display"	00:00		40
P182*	Stop time for time window "title display"	00:00		40
P183*	Active on week-day(s) "D" (D = 1 to 7) (D=no, 1=yes) +H	0		40
P184*	Timeout for the setting of the title display 0+H = no automatically setting of the title display 1 99+H = time to the next setting in minutes	0		40
P185*	Entry of 20 positions of the title display define # left at the top + H	0		41
P186*	Mode for setting after timeout 0+H = continually movement of title stnps in Stand-By for one position or to the next programmed position 1+H = single movement in Stand-By to the next programmed position 2 + H= continually movement of title stnps for one position or to the next programmed position 3+H= single movement to the next programmed position.	0		41
P187*	Limitation of the positions in the title display 0+H = number of positions in title display = number of CDs 1 100+H = Entry of the occupied positions in the title display	0		41

## 2.4. The structure of the service program steps

The whole service program steps are divided into program groups

Table 4: Overview of program groups of the service program

Group	Name of command group	program steps	from page
1.	Authorization / Version	P001... P003	7
2.	Statistics	P010 ... P029	8
3.	Data Transfer/Cancellation	P030 ... P033	11
4.	Programming General Settings	P040 ... P057	13
5.	Programming Price Settings	P060 ... P066	18
6.	Programming Monetary Value Settings	P070 ... P078	19
7.	Programming Real Time Clock	P080 ... P082	22
8.	Programming Free Credits	P090 ... P095	24
9.	Programming Background Music	P100 ... P108	26
10.	Programming Auto Play	P110 ... P117	28
11.	Programming Advertising	P120 ... P127	30
12.	Programming Lock-out titles	P130 ... P135	32
13.	Programming Happy-Hour-credits	P140 ... P144	34
14.	Test Programs	P150 ... P159	35
15.	Initializing CD titles into title memory	P160 ... P163	38
16.	Switching signal sources	P164	39
17.	Switching signal sources	P170 (only GB)	39
18.	Programming the title display	P180 ... P187*	40

\* This program group is not valid for the "small" title display with 3x18 title strips without CD cover.

The following chapter will describe the meaning and the syntax of each command of the service program in detail

## 2.5. Authorization (P001 to P002) / Show Version (P003)

Because the jukeboxes can be programmed with so much important data as well as input in cash counter and statistics, it is even more important than before that only authorized personnel may have access. For this reason access to essential data of the phonograph can be protected by using an authorization code.

### 2.5.1. Enter Authorization Code

**P001** In order to call up the protected programs, one must start authorization by using the P001 command.

Enter: P 001 H P P P P H or P 1 H P P P P H

Enter: P 001 H P P P P H (for authorization)



The authorization code "0000" has been programmed for delivery. The memories are not protected and the operator can choose his own code by entering command P002. For security reasons the code number is not shown. In the display each number is shown as "P. When "PPPP" is shown, the secret code number is complete and after pressing "H" and leaving the programming mode, the machine is protected.

### 2.5.2. Changing the Authorization Code

**P002:** During regular operation changing of the authorization code is only possible after entering previous authorization code

Enter: P 002 H P P P P H (when entering new authorization code)

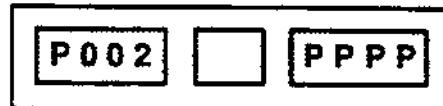

**Caution:** As described beforehand, the authorization code is NEVER shown! Therefore, it is important that the code is never lost since there is no opportunity to reprogram the phonograph.

### 2.5.3. Show version

**P003:** Enter this program to get the version of the firmware of the phonograph the CD changer MBC III or the CD player

Enter: P 003 H 0 shows the version of the phonograph s firmware

1 shows the version of the CD changer MBC III:

2 shows the version of the CD player:

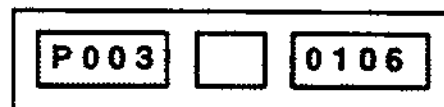

## 2.6. Statistics (P010 to P029)

Within the program group of statistics there is information regarding cash as well as statements as to how often CDs are played (popularity, hit parade).

The single programs for cash value and counters are divided into two groups. The regular information is under code "0". Cumulated values are under code "1" which have been added up since the jukebox has been operated.

Individual programs:

### 2.6.1. Popularity

Relating to CD albums, the programs P010 and P011 are dedicated in order to determine the popularity.

- P010:**
- 0: Display of number of **least played CD**
  - 1: Display of number of the next more often played CD (stepping through with "1")
  - 2: Number of plays
  - 3: Information to any CD (enter CD number)

After entering the proper code, the display shows the information such as the following:

Enter: P 010 H 0      i.e. least played CD no. 45  
                          1

P 010	1	45
-------	---	----

Enter: P 010 H 2      i.e. 13269 plays

P 010	1	3269
-------	---	------

Enter: P 010 H 3 53 H      i.e. CD no. 53 in 17th place

P 010	17	53
-------	----	----

- P011:**
- 0: Display of number of **most popular CD**
  - 1: Display of number of next worst CD (advance with "1")
  - 2: Number of plays
  - 3: Information regarding any CD (enter CD number).

After entering the proper code, the display shows the respective data.

Enter: P 011 H 0      i.e. most popular CD no. 19  
                          1

P 011	1	19
-------	---	----

Enter: P 011 H 2      i.e. 731 plays

P 011		731
-------	--	-----

Enter: P 011 H 3 24 H      i.e. CD no. 24 in 2nd place

P 011	2	24
-------	---	----



## 2.6.2. Hit Parade

The hitparade of the phonograph has a range of 500 titles each to count up to 65535. Titles and counters are stored until the next read-out with P030 or the next clearing with P033.

With DATAprint only the TOP TEN hitparade is printed to save capacity and paper. On special request you can print out the 500-hitlist (see P031).

**P012:** With P012 you can read out a 100-hitlist of the phonograph:

- 0: Display of the number of the top title, Hit no. 1
- 1: Display number of the next worst title (advance with key "1")
- 2: Number of plays of the actual title

Enter: P 012 H 0

1     *i.e. in 16th place:  
The third title of CD 01*

2     *i.e. this title was played  
169 times until now*

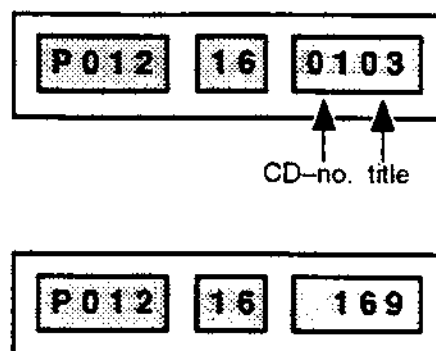

## 2.6.3. Contents of the statistical counters

Use the following commands to display the actual cash contents as well as diverse counter readings since the last collection. You receive statistics concerning the entire time of operation by displaying the cumulated counters.

### 2.6.4. Cashbox contents

The display of the cash amount is done by total numbers, read out in currency amounts. It is calculated on the basis of the programmed value setting in command group P07x (i.e. \$1,- is entered as 0100 in P07x). As cashbox contents the cash amount divided by 100 (depending on the programming of P078 also divided by 10 is possible) is displayed on displays 2 and 3. The remainder of the division is ignored.

Example: calculated cashbox content of 123450 is displayed as 1234 (= \$1.234,- while P078 = 0)

calculated cashbox content of 123450 is displayed as 12345 (= \$1.234,50- while P078 = 1)

Display of the cash contents is indicated by maximum 6 spaces (max. display = \$ 99 9.999,- ).

**P013:** 0: display of cash contents since the last collection  
1: cumulated cash contents

Enter P 013 H 0

1     *i.e. \$34.829,-*

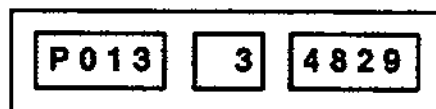

## 2.6.5. Counter for number of coins / bills

Besides displaying the cash levels, the counters of the individual money chutes can be called up.

This makes possible an additional control of the cash contents.

The five integrated counters are distributed as follows:

Chutes 1 to 3: only coins (defined by monetary value setting P071 to P073)

Chute 4 and 5: coins as well as bills (can be selected with P074 to P075)

The total of the individual counters corresponds to the total of the cashbox contents.

- P014:** 0: Number of coins through Chute 1 (enter P071)  
 1: Number of coins through Chute 2 (enter P072)  
 2: Number of coins through Chute 3 (enter P073)  
 3: Number of coins through Chute 4 and/or bills counted in Bill validator 1 (enter P074)  
 4: Number of coins through Chute 5 and/or bills counted in Bill validator 2 (enter P075)  
 5: Cumulated counter Chute 1 (enter P071)  
 6: Cumulated counter Chute 2 (enter P072)  
 7: Cumulated counter Chute 3 (enter P073)  
 8: Cumulated counter Chute 4 (enter P074)  
 9: Cumulated counter Chute 5 (enter P075)

Enter: P 014 H 0

1 i.e. 12.543 coins through  
 2 channel 2:  
 ...



The respective cashbox total is derived by multiplying: number of coins x monetary value of coin.

### 2.6.6. Additional Counters

With programs P016 to P026 diverse counters can be called up which can be used as actual counters and as cumulative ones as the commands described previously. The statistical data contained therein can be used to settle accounts.

- P016:** 0: Number of titles played (1: Cumulated counter)  
**P017:** 0: Number of titles chosen (1: Cumulated counter)  
**P018:** 0: Number of albums chosen (1: Cumulated counter)  
**P019:** 0: Number of overplay titles (1: Cumulated counter)  
**P020:** 0: Number of credits paid (1: Cumulated counter)  
**P021:** 0: Number of free credits (1: Cumulated counter)  
**P022:** 0: Number of background titles (1: Cumulated counter)  
**P023:** 0: Number of titles in auto play mode (1: Cumulated counter)  
**P024:** 0: Number of advertising titles (1: Cumulated counter)  
**P025:** 0: Number of Happy-Hour-credits (1: Cumulated counter)  
**P026:** 0: Counter for power-on hours (range from 1-65536 hours, 1: Cumulated counter)

I.e.: calling up number of titles played: a total of 10273 titles were played on this phonograph.

Enter: P 016 H 1 i.e. 10.273 titles played  
 in total



Further interesting data are recorded in counters P028 and P029.

**P028:** Number of credits unused.  
 This shows the number of paid credits available for selections of titles or albums.

**P029:** Number of chosen unplayed titles.  
 This shows how many entries are remaining in the selection storage.

## 2.7. Printout of the statistical data (P030 to P031)

In this group of service programs commands the contents of the counters mentioned beforehand are prepared for output to a DATAprint or to evaluation devices which process the data. After calling up the corresponding program and entering the respective code, data transfer follows.

There are two possibilities to print out the statistical data:

**P030** transfers all available data in text mode.

The data is stored within the DATAprint.

The Data can be printed out or edited on a PC i.e. with the software DATAcontact.

The counters of the phonograph are deleted after the printout is done and the cabinet is closed.

**P031** transfers all data in graphic mode.

The data is printed out directly after downloading.

See also the sample printouts shown in section "valuation of the statistic?"

### 2.7.1. DATAprint, printout in text mode

**P030:** 0: All data in the counters is processed and sent to DATAprint.

There they are stored and printed out depending on the setting of the DATAprint.

1: Only the hitparade will be sent to DATAprint (max. 500 titles).

The stored data can continue to be processed by a software tool for PCs, i.e. by DATAcontact.

Enter P 030 H 0



**Note:** *The counters of the phonograph are cleared after the print out is done and the service switch is closed manually or after closing the front door/lid of the cabinet.*

### 2.7.2. DATAprint, printout in graphic mode

Contrary to the output of P030, the entire statistics as well as individual statistical areas can be printed out by P031. But the data are not stored within the DATAprint.

**P031:** 0 Print all data

1 Cashbox amount

2 Counter with cashbox

3 General settings

4 Popularity of all CDs

5 Hitparade over all titles (max. 500 titles)

6 The last 20 errors shown

Enter P 031 H 0

1

...

6

i.e. 4 print-out popularity:



**Note:** *The counters are not cleared after closing the door/lid of the cabinet.*

If you just would not have selected this menu item, you just push in then pull out the service switch and you re-enter the service mode at the main menu level.

### 2.7.3. Display of error numbers while transferring/printing

If an error is determined, "E0" is shown in display 3. In that case, please check the connection to the DATAprint unit.

Display of the phonograph if a transfer error occurs:



Remember to un-plug the interface cord after the print out is finished.

### 2.8. Clearing the statistical counters (P033)

The P30 group contains not only the printing commands but also the command for clearing counters P010 to P026. Thus to define a new statistical period.

Only the "regular" counters are cleared. The cumulated counters are not cleared.

The memories contents for credit and selection of titles as well as the error memory are cleared too.

*Note: To avoid the clearing of data by accident or by unauthorized persons, this function can be protected by an authorization code (see P001).*

- P033:**
- 0+H: Clear all memory contents
  - 1+H: Clear hit parade (P012)
  - 2+H: Clear popularity (P010)
  - 3+H: Clear counters and cashbox contents (P013-P024)
  - 4+H: Clear credit memory
  - 5+H: Clear selection memory
  - 6+H: Clear error memory
- Attention!**

*Note: To additionally safeguard accidental clear programs, each input has to be confirmed by pressing the key "H".*

Enter P 033 H 0 H  
           1 H  
           2 H   *i.e. clear popularity*  
           6 H

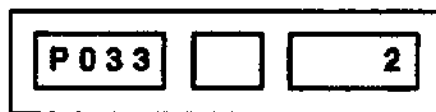

## 2.9. Programming General Settings P040 to P057

In order to adjust each phonograph individually to the location requirements, certain general settings can be individually changed. Below you may find detailed values which have been set at the factory.

### 2.9.1. Default values

If you generally want to reset all values to the standard values of the factory settings, you have to perform this program step.

#### **P040:** 0+H: programming of **default values** (P041 to P057)

After calling this code the values of P041 to P144 are cleared:

P042 =	0032:	Max. number of CD/titles
P043 =	1105:	Light play in stand-by, if installed
P044 =	1000:	Light play in play mode, if installed
P049 =	2:	Cancel credits after power-off (=12 min.)
P050 =	.	Cancel selection memory after power-off (=12 min.)
P051 =	31:	Max. volume in play mode (max.31)
P052 =	16:	Max. volume for background music (max. 31)
P053 =	0505:	Volume setting
P054 =	0808:	Sound setting
P055 =	0:	Max. volume for microphone (= same as play mode volume)
P056 =	2:	Display hitparade on operators console
P057 =	0:	Cancel selection memory with remote control

#### **P040:** 1+H: as above, but plus additional programming of default values for:

P114 =	15:	autoplay titles with
P117 =	1:	defined acces to all CDs in random mode.

Enter: P 040 H 0 H  
1 H i.e. set factory default

P 0 4 0		0
---------	--	---

### 2.9.2. I.D. number of the phonograph

**P041:** Every phonograph can be programmed with its own I.D. number. DATAprint printouts can then be easily identified if you have evaluated several machines. The I.D. number has at most 4 digits.

Enter: P 041 H nnnn H

P 0 4 1		2 6 0 2
---------	--	---------

### 2.9.3. Maximum number of selectable CDs and tracks/titles

**P042:** When partially equipping phonographs, unused magazine slots can be excluded. A maximum of 100 CDs (01-to 00) as well as a maximum of 99 titles can thus be selected. (Default value: 0032). The number 100 is displayed as 00.

Enter: P 042 H 0032 H

*i.e. allow 100 CDs with  
32 titles each to be selected*

P 042		0032
-------	--	------

**Note:** Please remember that with each change regarding the number of CDs, the new parameters should be reported to the phonograph via program step P160 or P161. Otherwise, there will be problems when playing the CD.

**Attention:**

Some phonographs are equipped with a CD changer for only 50 CDs (MBC III-50). Thus the maximum number of selectable CDs is limited to 50. The default value of P042 therefore is 5032.

### 2.9.4. Limit play time of one track

**P045:** in minutes; in order to suppress long titles play time can be limited. The title playing will slowly fade when the time is up. When entering 0, there is no limit.

Enter: P 045 H nn H

*3 H: titles will slowly fade after 3 min.*

P 045		3
-------	--	---

### 2.9.5. Sequence of plays at normal selection

**P046** In order to alter the music menu, three variations can be chosen when playing :  
 0: play as selected (FIFO)  
 1: play in numerically ascending numbers  
 2: play randomly (RANDOM).

Enter: P 046 H n H

*2 H i.e. play randomly*

P 046		2
-------	--	---

### 2.9.6. Maximum number of titles of one CD

**P047:** Use this program step to determine how many titles of one CD are played in sequence. Value "n" as number of titles to be played. "0" means no limit.

Enter: P 047 H n H

*0 H i. e. no limit*

P 047		0
-------	--	---

### 2.9.7. Cancel credit

**P049:** Remaining credits are cancelled after  $n/10$  hours ( $n \times 6$  min.) of power off or stand-by.

Value "n" can be between 0 and 240 with programs P049 and P050.

i.e.                     $n = 1$ : waiting time = 6 min.  
                           $n = 10$ : waiting time = 1 hr.  
                           $n = 240$ : waiting time = 24 hrs.

$n = 0$  does not cancel any remaining credit.

Enter: P 049 H 2 H

*i.e. cancel credit after 12 min. of  
power off/stand-by (2/10 hrs.):*



### 2.9.8. Cancel selection memory

**P050:** Remaining selections entered in the selection memory are cancelled after  $n/10$  hours ( $n \times 6$  min.) of power off.

Value "n" can be between 0 and 240 with programs P049 and P050.

i.e.                     $n = 1$ : waiting time = 6 min.  
                           $n = 10$ : waiting time = 1 hr.  
                           $n = 240$ : waiting time = 24 hrs.

$n = 0$  does not cancel any remaining selection.

Enter: P 050 H 4 H

*i.e. cancel selection memory  
after 24 min. of power off:*



## 2.10. Sound system settings

### 2.10.1. Maximum Volume Levels

Maximum volume levels during play and background mode can be pre-set to a certain limit. The manually adjustable volume level of the phonograph cannot go beyond the set levels.

**P051:** Maximum volume during **play**; can be set between 0 (mute) and 31 (loud).

**P052:** Maximum volume for **background mode**

- 0: The background volume is like the phonograph's volume
- n: Separate volume setting for background music (values n=1 to n=31)  
The programmed value is the maximum background volume (default = 16).

Enter: P 051 H 31 H  
i.e. maximum volume possible



### 2.10.2. Set volume for play mode

**P053:** With this program the volume of the phonograph is set.

This function can be set in two ways:

In the program mode it can be set via the key pad of the phonograph or by using the remote control (optional equipment).

In play mode it can be set via the volume buttons at the bottom of the phonograph or by using the remote control (optional equipment).

Key pad layout for volume setting:

1 ▲ left channel louder	2 ▲ both channels louder	3 ▲ right channel louder
4	5	6
7 ▼ left channel quieter	8 ▼ both channels quieter	9 ▼ right channel quieter
C Cancel	0	H Step to the next com- mand.

Figure 31 Key pad layout for volume setting

Enter: P 053 H  
Change per pressing keys  
i.e. Key "2" = louder

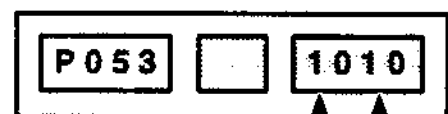

channel value: left, right



### 2.10.3. Sound setting

**P054:** With program P054 the sound setting is performed in a range from 1 to 10. Here treble and bass volume are set for both channels at the same time. The changed setting can also be immediately heard.:

#### Key pad layout for sound setting

▲ 1 more bass	▲ 2 more bass + treble	▲ 3 more treble
4 mean value	5 mean values	6 mean value
▼ 7 less bass	▼ 8 less bass + treble	▼ 9 less treble
C Cancel	0	H Step to the next command.

Figure 32: Key pad layout for sound setting

Enter: P 054 H

Change per pressing keys  
i.e. Key "8" = less bass and treble

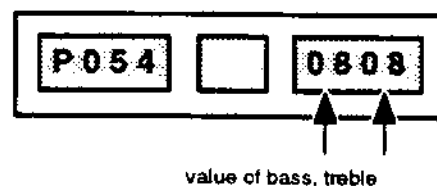

### 2.10.4. Maximum volume for microphone

**P055:** With program P055 the maximum volume level for microphone is set. The set volume is the max. value for microphone volume.

- 0 Microphone volume = normal phonograph's volume (default value)
- n Separated microphone volume. range: n= 1 to n=31

The two dashes on the left side indicate that the microphone is switched on



### 2.10.5. Display the hitparade on the operators console display

**P056:** With program P056 the display mode of the operators console is defined.

- 0 No hitparade display. **only credits are displayed**
- 1 Hitparade displayed 16 seconds after selection or registered credits
- 2 Hitparade displayed 16 seconds **only if credits available.** (default value)

### 2.10.6. Clear selection memory using remote control

**P057:** With program P057 the selection memory can be cleared using the remote control unit.

- 0 Clearing of selection memory is not possible (default value)
- 1 Clear selection memory as follows  
Press "MUTING" + "REJECT" + "REJECT" + "REJECT" on the remote control unit within 10 seconds

### 2.10.7. Maximum volume for tape

**P058:** With program P058 the maximum volume level for tape input is set. The set volume is the max. value for tape volume.

- 0. Tape volume = normal phonograph's volume (default value)
- n: Separated tape volume. range: n= 1 to n=31

## 2.11. Price Settings P060 to P066

To make programming of credits easier a table for price settings, via code number, has been programmed for program **P060** in which actual price values have been entered. The programming of the five possible price levels can be automatized with the table.

Look for your country and enter the code number for those listed prices. Another possibility is the individual programming of the individual price scales using commands **P061** to **P065**.

Please use 6 digits and keep the price settings in numerically increasing order (ie: **P061** lowest price, **P065** highest price)

### 2.11.1. Programming the price settings by default values

**P060:** In order to program the phonograph with the default values of the table, the respective code number is entered after command P060 and confirmed with "H". The setting selected (n = code no. of the table) is automatically matched to the respective price scales.

Enter: P 060 H n H  
16 H i.e. price setting: GB

P 060		16
-------	--	----

Table 5: Price Settings, predefined examples

Code No.	COUNTRY	P061	P062	P063	P064	P065	Remarks
0		00 0000	00 0000	00 0000	00 0000	00 0000	no coin conversion in this setting
1	Germany	01 0100	01 0100	03 0200	03 0200	03 0200	1 play = 1.-DM
2	Belgium	02 2000	02 2000	02 2000	06 5000	06 5000	
3	Netherlands	02 0100	02 0100	02 0100	06 0250	06 0250	2 different settings
4	France	02 0500	02 0500	10 1000	10 1000	10 1000	
5	Switzerland	02 0100	02 0100	05 0200	05 0200	14 0500	
6	Austria	01 0500	01 0500	03 1000	03 1000	07 2000	
7	Italy	01 0400	01 0400	01 0400	03 1000	03 1000	
8	Spain	01 0050	01 0050	02 0100	02 0100	05 0200	
9	Greece	01 2000	01 2000	01 2000	02 5000	02 5000	
10	Yugoslavia	01 0200	01 0200	01 0200	03 0500	03 0500	
11	Denmark	01 0300	01 0300	02 0500	05 1000	12 2000	4 different settings
12	Norway	01 0300	01 0300	02 0500	02 0500	04 1000	
13	Finland/Sweden	01 0300	01 0300	01 0300	02 0500	02 0500	
14	Hungary	01 2000	01 2000	01 2000	01 2000	01 2000	
15	Ireland	01 0010	01 0010	03 0020	03 0020	10 0050	
16	Great Britain	01 0030	01 0030	02 0050	02 0050	05 0100	
17	USA (1) / Canada	01 0050	01 0050	01 0050	03 0100	03 0100	Dollarbill on chan.5 (P065)
18	USA (2)	01 0050	01 0050	03 0100	03 0100	18 0500	
19	Africa	01 0020	01 0020	03 0050	03 0050	07 0100	
20	Australia	01 0100	01 0100	01 0100	05 0400	05 0400	
21	Netherl. Antillen	01 0400	01 0400	01 0400	01 0400	01 0400	
22	New Zealand	01 0050	01 0050	01 0050	01 0050	01 0050	

### 2.11.2. Programming the price settings with custom settings

**P061 to P065:** The credit value for the individual price scales can also be separately defined. With programs P061 to P065 the respective credit value can be programmed. You just have to observe the order of entering the values: P061 is programmed with the lowest and P065 is programmed with the highest price setting. Unused steps may be programmed with zero or with the preceding value (examples see table)

Example of individual price setting: 12 titles for £ 5,- (price scale 3).

Enter: P 065 H 050100 H



### 2.11.3. Programming an album bonus

**P066:** The setting of bonus credits for album selection is done with program P066 in the service program. The following settings are permitted:  
 0: no album selection possible  
 1: no bonus (default setting), this means credit for each track on the album.  
 2: 1 bonus for every 5th track,  
 3: 1 bonus for every 4th track,  
 4: 1 bonus for every 3rd track.

Setting is confirmed by pressing "H".

Enter: P 066 H 0 H  
           1     i.e. no bonus  
           ...  
           4



## 2.12. Monetary Value Setting P070 to P078

As with the price setting, the identification of the different coins as related to values processed by the phonograph, can be done automatically with the pre-defined basic values. Table 6 "Monetary Value Settings" shows which setting can be programmed as basic value.

### 2.12.1. Standard values

**P070** The standard values of the table are selected with command P070 "n" + "H" (n = code no. from table 6). Also the default value for the kind of money conversion is set: P077=0

Enter: P 070 H n H  
           9 H   i.e. GB



"n" is the code number for the setting according to table 6. To avoid erroneous entries, each entry has to be confirmed by "H". This is very important since entry of Code Number "0" cancels the current monetary value setting and no currency acceptance is possible.

### 2.12.2. Individual monetary values

**P071 to P075:** The monetary value settings for different coin values of each chute can be individually identified. This is easily done by inserting one or more coins after command P070 has been called up. According to the coin value the program changes to the proper chute command P071 to P075. On display 1 the monetary value of each coin is displayed. This can be changed as needed. Unused chutes have to be programmed with monetary value 0.

Entries occur in the smallest counting unit of each currency that makes sense, for example GB: with £1,- ⇒ 0100. Normally the standard setting is sufficient.

### 2.12.3. Bonus Credits

**P076:** With this program another bonus (value n = 0 to 4) is defined: the bonus for paying with bills instead of coins. When accepting a bill, this bonus is added to the regular credits.

Enter: P 076 H nn H  
3 H i.e. 3 bonus credits

P 076		3
-------	--	---

### 2.12.4. Indirect / direct money to credit revaluation

**P077:** Use this program to differ between the how and when of the revaluation of inserted coins.  
 0+H: Indirect revaluation: inserted coins are stored. At an appointed coins value the credit is defined from the highest possible price setting, including a possible bonus.  
 1+H: Direct revaluation: inserted coins are revaluated directly after insertion.  
 Then no bonus is possible with multiple insertion of coins.

Enter: P 077 H n H  
0 H i.e. indirect revaluation

P 077		0
-------	--	---

### 2.12.5. Programming the cash counter P013 and the electromechanical cash counter

**P078:** With this setting you can define whether values of inserted coins are counted as value/100 or value/10.  
 This setting is used to display/print-out the cashbox contents in P013 and with DATAprint too.

- 0 Counted as value divided by 100 (example: 10.00 £ → counted 10)
- 1 Counted as value divided by 10 (example: 10.00 £ → counted 100)

Default value = 0

Enter P 078 H n H  
0 H i.e. divide by 100

P 078		0
-------	--	---

Table 6: Monetary Value Settings, predefined examples

Table No.	COUNTRY	channel 1(P071)	channel 2(P072)	channel 3(P073)	channel 4(P074)	channel 5(P075)	Remarks, example for 1 chan.
0		0	0	0	0	0	no coin conversion
	<b>mechanical coin acceptor</b>						
1	Germany, Switzerland, Venezuela	100	500	200	0	0	100 = 1,-DM 100 = 1 sfr 100 = 1,-Bol
2	Belgium	0	2000	500	0	0	2000 = 20 Bfr
3	Netherlands	25	250	100	0	0	250 = 2,5 hfl
4	Denmark, France	100	500	1000	0	0	100 = 1 dkr
5	Austria	500	2000	1000	0	0	500 = 5 ÖS
6	Italy	200	100	500	0	0	200 = 200 L
7	Spain	0	25	100	0	0	25 = 25 Pst
8	Finland, Norway, Yugoslavia	0	500	100	0	0	500 = 5 mK 500 = 5 Kr 500 = 5 Din
9	Great Britain, Ireland	20	50	10	0	0	20 = 20 p
10	USA	10	50	25	0	100	10 = 10 c, 100 = 1 \$
11	Canada	0	25	0	0	100	25 = 25 c, 100 = 1 \$
12	Union of South-Africa	20	100	50	0	0	20 = 20 c, 100 = 1 R
13	Australia	100	50	20	0	0	100 = 1 \$
14	Netherl. Antillen	0	100	25	0	0	100 = 1 NAF
	<b>electronic coin acceptor</b>						
15	Germany, Switzerland, Italy	500	100	0	200	0	500 = 5,-DM 500 = 5sfr 500 = 500 L
16	Belgium	5000	500	0	2000	0	100 = 1 Bfr
17	Netherlands	25	250	500	100	0	25 = 25 c, 500 = 5 hfl
18	France	1000	200	100	500	0	1000 = 10 F
19	Denmark, Austria	2000	500	100	1000	0	2000 = 20 dkr 2000 = 20 ÖS
20	Spain	200	50	25	100	0	200 = 200 Pst
21	Greece	0	50	20	0	0	50 = 0,5 Dr
22	Norway	1000	100	0	500	0	1000 = 10 Kr
23	Finland	0	500	100	0	0	200 = 200 L
24	Sweden	500	100	0	100	0	500 = 5 Kr
25	Great Britain	100	20	10	50	200	100 = 1£, 20 = 20 p
26	USA	100	25	0	50	0	100 = 1\$
27	Canada	10	100	25	0	0	10 = 10 c, 100 = 1 \$
28	Australia	0	100	20	200	0	200 = 2 \$
29	Netherl. Antillen	0	0	100	0	0	100 = 1 NAF
30	New Zealand	50	10	5	20	0	50 = 50 c

Chutes entered with "0" on this table are blocked. Be careful to block the coin pathways, so that these coins will not be accepted and are rather expelled through the coin return.

### 2.13. Programming Real Time Clock P080 to P082

The most important update starting with ES-V technology is the implementation of a real time clock. Referring to the data supplied by the clock, a number of functions have been developed that are dependent on chronological data for start and stop times. Together with the weekday programming which continues to be available, an "automatic program" for a whole week can be developed during which all functions operate automatically.

The real time clock runs quartz-precise with a battery backed power supply if the phonograph is turned off. The clock runs on military time.

#### 2.13.1. Set time

**P080:** Use this program to set the time of the phonographs control unit. The newly set minute information starts the counter for seconds automatically at zero.

Enter: P 080 H

*change per pressing keys i.e. 10.45 h*



▲ 1 hour + 1	2	▲ 3 minute + 1
4 12:00	5 00:00	6 30 minutes
▼ 7 hour - 1	8	▼ 9 minute - 1
C Cancel	0	H Step to the next command

Figure 33: Key pad layout for command "set time"

#### 2.13.2. Set date

**P081:** Use this program to set the date information of the phonographs control unit. The date is shown on displays 2 and 3

Enter: P 081 H

*change per pressing keys  
i.e. March 21, 1997*



▲ 1 day + 1	▲ 2 month + 1	▲ 3 year + 1
4	5	6
▼ 7 day - 1	▼ 8 month - 1	▼ 9 year - 1
C Cancel	0	H Step to the next command

Figure 34: Key pad layout for program "set date"

2.13.3. Set day code

**P082:** Use this program to set the day code for the current day of the week.

Day-code:  
 1 = Monday  
 2 = Tuesday  
 3 = Wednesday  
 4 = Thursday  
 5 = Friday  
 6 = Saturday  
 7 = Sunday

1	2	▲ 3 day code + 1
4	5	6
7	8	▼ 9 day code - 1
Cancel C	0	Step to the next program H

Figure 35: Key pad layout for program "set day code"

Enter: P 082 H

*change per pressing keys  
 i.e Thursday is 4:*



After confirming the week-day entry the jukebox switches to the next program.

The data supplied by the real time clock are processed by programs P090 to P185 (described as follows) for the so-called time windows. Here the entry of the time window values also occurs via the illustrated key pad layout.

Furthermore the information of time and date are used for the print-out of statistical data to the DATAprint (P030 and P031).

## 2.14. Programming Free Credits P090 to P095

Using the programs of command group P09x the operator is able to give free credits (music selection without coin insert) at specified times.

The amount of free credits are set as well as the time periods.

All times are based on a 24-hour clock (ie: afternoon times are from 13:00 to 23:00)

Free credits are only active if you have entered a value  $\neq 0$  in P094.

**P090:** Set P090 = 0; a standard setting cancels automatically the previous setting.  
The time factor is set to zero, so there are no automatic time periods for free credits.

Enter: P 090 H 0 H



**P091:** To set the starting time for the time window "free credit", the key pad is used (see P080).

Enter: P 091 H      Set by pressing keys  
i.e. starting time 12:34  
confirm setting with key "H".



**P092:** Here the stop time of the time window is set (see P080).

Enter: P 092 H      Set by pressing keys  
i.e. stopping time 13:45  
confirm setting with key "H".



**P093:** Here the day is chosen on which the defined time window is to become active.

On the middle display the days (according to the programs of P082) are shown as numbers 1 to 7. Each weekday can be activated individually. "1" means active on that day. "0" means non-active. The inputs must be confirmed by pressing "H". To simplify the entries it is defined that the whole week is active with "0" or "1" (for all days).

Enter: P 093 H      0 or 1 H  
Set per pressing keys  
i.e. monday is inactive  
confirm setting with key "H".



After confirming one day's entry the software steps to the following day.



**P094:** Activating free credits.  
Different settings are possible:

- 0: No free credits possible (default setting).
- <200: Limited free credit. Free credits can be used one at a time then subtract from total input.
- =200: Unlimited free credit while time window is active (switched via remote control).
- =201: Switching between no free credits and unlimited free credits while time window is active (switched via remote control).
- =202: Free play automatically while time window is active. If non-active switching is done via remote control.

Enter: P 094 H 200 H  
i.e. no free credit:



**P095:** Here the mode of rebuilding free credits is to be defined.  
Different settings are possible:

- 0: No automatic rebuild of free credits. Free credits only once in a service period (default setting).
- 1: Daily rebuild of free credits at midnight.
- 2: Weekly rebuild of free credits at midnight between Sunday and Monday.

Enter: P 095 H 0 H  
i.e. no rebuild:



**Note:** If all entries in P091, P092, P093 are set to "0" and if P094 is not set to "0" the time window will always be active.  
If no time window is programmed (P091, P092, P093 are set to "0") free credits are always active, if a value is entered in P094.

## 2.15. Programming Background Music P100 to P108

The phonograph operator can call up the background mode. This operational mode remains even after a power failure. If money is inserted into the machine and a title is selected, the background music is faded out and the "paid for selection" is started.

Background mode may be initiated up to four times a day, thus you have to enter four time windows for background mode. Background is active only if you have entered values  $\neq 0$  in P104.

**P100:** If the program P100 is entered, the display shows P100 \_1 \_\_\_\_\_. If you enter "0" and confirm with "H", the entries for the first time window is cleared. The display then shows P100 \_2 \_\_\_\_\_. You may enter "0" and "H" to clear the second time windows or you skip this by pressing "H" without previous "0". And so on with time window 3 and 4.

Enter: P 100 H 1 0 H  
 2 0 H  
 3 0 H  
 4 0 H

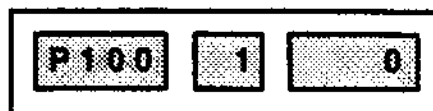

**P101:** With program P101 the starting time is set for the time window 1 to 4 of background mode. Key pad layout see P080.

Enter: P 101 H  
 Set per pressing keys  
 i.e. starting time 1 = 09.55 P.M.  
 confirm settings with key "H"  
 Display shows starting time 2,  
 enter value for second time window.  
 Confirm setting or  
 skip entry by pressing "H" without value.



**P102** With program P102 the stopping time is set for the time window of background music. Key pad layout see P080.

Enter P 102 H  
 Set per pressing key  
 i.e. stopping time 1 = 13.45P.M.  
 confirm settings with key "H"  
 Display shows stopping time 2,  
 enter value for second time window.  
 Confirm setting or  
 skip entry by pressing "H" without value.



**P103** With program P103 the week-days are set when background music should be played.

Enter P 103 H 1 and/or 2 and/or 3 and/or 4 and H  
 Set per pressing keys  
 i.e. all four time windows are active  
 for wednesday  
 Confirm settings with key "H"  
 If you don't enter a number 1, 2, 3, or 4  
 the corresponding time window is inactive for this week-day.

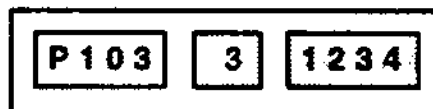

With confirming one entry the software steps to the following week-day. If you again enter P103 the display shows, e.g.

Enter: P 103 H  
 Here 1 0204 means that on monday  
 i.e. only time windows 2 and 4 are active  
 but time windows 1 and 3 are inactive.

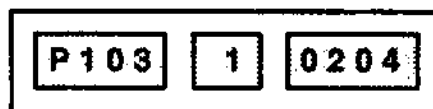

**P104:** With program P104 the mode of operation is set for each time window. Three types are possible:  
 0: no background music. This value is the factory setting.  
 1: allows starting and stopping background music by pressing the background key on phonograph or on remote control in the time window.  
 2: automatically plays background music at defined times of the time window.

Enter: P 104 H n H  
 2 H *i.e. automatically within the time window.*

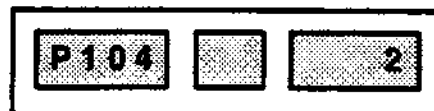

**P105:** The titles to be played as background music, are defined by the operator. With program P105, followed by **80 four-digit entries**( 20 entries each for time windows 1 to 4), titles or CDs may be defined. With no entry in P105 all CDs (defined by P042 to be selectable) are played.

Enter: P 105 H nnnn H  
 1703 *i.e. first entry: CD #17 title 3 and so on.*



**Up to 80 entries always confirmed by pressing "H".**  
 The sequence of input is:  
 1...20 titles for time window 1  
 21...40 titles for time window 2  
 41...60 titles for time window 3  
 61...80 titles for time window 4.

Clear erroneous input by pressing key "C" once  
 Early termination is possible by pressing key "C" twice

**P106:** The "Patron Selection" enables or disables the selection of titles by other customers while the time windows is active  
 0: titles and albums free for selection.  
 1: titles or albums are locked

Enter: P 106 H 1 n H  
 1 0 H *i.e. while time window 1 titles are not locked*  
 2 1 H *while time window 2 titles are locked, and so on*



**P107:** The titles selected in P105 are played in the sequence selected in P107. This is also defined separately for each time window  
 0: sequence of play in order of entry (FIFO), factory setting  
 1: random play (RANDOM)

Enter: P 107 Hn H  
 1 0 H *while time win 1 titles are played FIFO*  
 2 1 H *while time win 2 titles are played randomly, and so on*



**P108:** With this step background music can be set up in such a way that it has to be paid for. In this case, every time BGM is turned on "n" credits are subtracted, independent of the number of titles to be played. When n=0 no credits are deducted.  
 0: Background music as in the past, without credit.  
 n: Background music deducts "n" credits (n=1 to 99).

Enter: P 108 H n H  
 2 H *i.e. two credits are deducted:*



## 2.16. Programming Auto Play P110 to P117

The phonograph can be programmed to automatically play a title once in a while to attract the audience during stand-by, when no selections are being made. The factory setting (P040=1) makes it possible that any title is played every 15 minutes (P114=15, P117=1).

Auto play is active only if you have entered a value  $\neq 0$  in P114.

**P110:** The standard setting is "no auto play" because with command "P110 0+H" all entries in group P11x are set to zero.

Enter: P 110H 0 H

*i.e. set default values:*

P 110		0
-------	--	---

**P111:** With program P111 the starting time is set for the time window of auto play.  
Key pad layout see P080.

Enter: P 111 H

*Set per pressing keys  
i.e. starting time = 12.34 P.M.  
confirm settings with key "H"*

P 111		1234
-------	--	------

**P112:** With program P112 the stopping time is set for the time window of auto play.  
Key pad layout see P080

Enter: P 112 H

*Set per pressing keys  
i.e. stopping time = 13.45 P.M.  
confirm settings with key "H"*

P 112		1345
-------	--	------

**P113:** With program P113 the days are set on which auto play should be active.  
Key pad layout see P082.

Enter: P 113 H 0 or 1 H

*Set per pressing keys  
i.e. wednesday inactive:  
confirm settings with key "H"*

P 113	3	0
-------	---	---

After confirming one day's entry the software steps to the following day

**P114:** Define whether and when the auto plays are played:  
0+H: no auto play  
nn+H: time between two titles (nn = max. 99 minutes)

Enter: P 114 H nn H

*30 H i.e. all 30 minutes play an  
animation title*

P 114		30
-------	--	----

**P115:** With program P115 followed by 20 four-digit entries (value nnnn), 20 titles or albums can be defined. Without entry in P105 all CDs (defined by P042 to be selectable) are played.

Enter: P 115 H nnnn H  
9700 i.e.first entry: CD # 97 all titles  
and  
so  
on.

P 115		9700
-------	--	------

Up to 20 entries always confirmed by pressing "H".

Clear erroneous input by pressing key "C" **once**.  
Early termination is possible by pressing key "C" **twice**.

**P116:** also defines a "Patron Selection" (see P106) which defines if a title is locked or not  
0: titles and albums are free for selection  
1: titles and albums are locked.

Enter: P 116 H n H  
0 H i.e. titles are not locked:

P 116		0
-------	--	---

**P117** defines the sequence of play for the titles or albums chosen under P115.  
0: Play in sequence of entry (FIFO)  
1: Play randomly (RANDOM)

Enter: P 117 H n H  
1 H i.e. play randomly:

P 117		1
-------	--	---

## 2.17. Programming Advertisements P120 to P127

The broad distribution of CDs has led to advertising for various areas being recorded on CDs. Thus, you have another source of income with phonographs with ES-V technology. Standard value is again "no advertising".

**P120:** With the program "P120 0+H" all entries of group P12x are cancelled (set to zero) and no advertising is played.

Enter: P 120 H 0 H  
i.e. set default values:



**P121:** With P121 the starting time is set for advertisement play. See P080 for key pad layout.

Enter: P 121 H  
Set per pressing keys  
i.e. starting time = 12.34 P.M.  
confirm settings with key "H"



**P122:** With P122 the stopping time is set for advertisement play. See P080 for key pad layout.

Enter: P 122 H  
Set per pressing keys  
i.e. stopping time = 13.45 P.M.  
confirm settings with key "H"



**P123** With P123 the is set for advertisement play. Show keypad layout again here.

Enter: P 123 H 0 or 1 H  
Set per pressing keys  
i.e. sunday inactive:  
confirm settings with key "H"

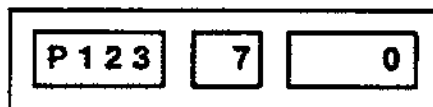

After confirming one day's entry the software steps to the following day.

**P124** With P124 it is set if or if not and how much time between advertising spots should be allowed.  
0+H no advertisement play  
nn+H time between titles (nn = max. 99 minutes).

Enter: P 124 H nn H  
30 H i.e. play a title  
every 30 minutes:



**P125:** With program P125 followed by 20 four-digit entries (value nnnn), 20 titles or albums can be defined.

Enter: P 125 H nnnn H  
 9003 i.e. first entry: CD # 90 3.title  
 and  
 so  
 on.

P 125	1	9003
-------	---	------

Up to 20 entries always confirmed by pressing "H".

Clear erroneous input by pressing key "C" **once**.  
 Early termination is possible by pressing key "C" **twice**.

**P126:** defines "patron selection" again. See 106.  
 0: titles and albums are free for selection  
 1: titles and albums are locked.

Enter: P 126 H n H  
 0 H e.g.: titles and albums are locked

P 126		0
-------	--	---

**P127:** defines the playing sequence for advertising spots selected with P125.  
 0: Play in sequence of entry (FIFO)  
 1: Play randomly (RANDOM)

Enter: P 127 H n H  
 1 H e.g.: play randomly:

P 127		1
-------	--	---

## 2.18. Programming Lock-Out Titles P130 to P135

At certain times it may be necessary to lock-out one or more titles from being played. Perhaps these titles should not be played by minors or are simply damaged (bad playing quality). Standard is that all titles can be played.

**P130:** If the program P130 is entered, the display shows P130 \_1 \_\_\_\_\_. If you enter "0" and confirm with "H", the entries for the first time window is cleared. The display then shows P130 \_2 \_\_\_\_\_. You may enter "0" and "H" to clear the second time windows or you skip this by pressing "H" without previous "0". And so on with time window 3 and 4.

Enter: P 130 H 1 0 H  
 2 0 H  
 3 0 H  
 4 0 H to clear all four time windows.



**P131:** With program P131 the starting time is set for the time window 1 to 4 of lock-out. Key pad layout see P080.

Enter: P 131 H  
 Set per pressing keys  
 i.e. starting time 1 = 06.45 P.M.  
 confirm settings with key "H"  
 Display shows starting time 2,  
 enter value for second time window.  
 Confirm setting or  
 skip entry by pressing "H" without value.



**P132:** With program P132 the stopping time is set for the time window of lock-out. Key pad layout see P080.

Enter: P 132 H  
 Set per pressing key  
 i.e. stopping time 1 = 09.45 P.M.  
 confirm settings with key "H"  
 Display shows stopping time 2,  
 enter value for second time window.  
 Confirm setting or  
 skip entry by pressing "H" without value.



**P133:** With program P133 the week-days are set when lock-out should be active.

Enter: P 133 H 1 and/or 2 and/or 3 and/or 4 and H  
 Set per pressing keys  
 i.e. all four time windows are active  
 for wednesday  
 Confirm settings with key "H"  
 If you don't enter a number 1, 2, 3, or 4  
 the corresponding time window is inactive for this week-day.



With confirming one entry the software steps to the following week-day. If you again enter P133 the display shows, e.g.

Enter: P 133 H  
 Here 1 0204 means that on monday  
 i.e. only time windows 2 and 4 are active  
 but time windows 1 and 3 are inactive.





**P134:** With this program you define the mode of operation for each time windows 1 to 4:  
 0+H the titles can be selected while the time window is active.  
 1+H the titles are locked-out.

Enter: P 134 H 1 n H

1 0 H i.e. all titles are selectable within  
 the time window 1:  
 confirm settings with key "H"  
 2 n H and so on for time windows 2, 3, and 4.



**Note:** If you select a locked-out title to be played the "Error-Lamp" in the operators display flashes for about 2 sec. and the display shows:



**P135:** defines a maximum of 80 titles or CD (20 for each time window) which are supposed to be locked-out. Input occurs with 4 digits for the CD number (nn\_\_) and the title (\_\_nn).

Enter: P 135 H 1 nnnn H

1 8500 i.e. 1.entry: CD #85 all titles  
 and  
 so  
 on.



**Up to 80 entries always confirmed by pressing "H".**  
 The sequence of input is:  
 1...20 titles for time window 1  
 21...40 titles for time window 2  
 41...60 titles for time window 3  
 61...80 titles for time window 4.

Clear erroneous input by pressing key "C" **once**.  
 Early termination is possible by pressing key "C" **twice**.

**Note:** Take care to change entries in P135 (if necessary delete entry) to a certain CD number if you change this CD. To delete an entry you step through the list of P135 by pressing key "H" as long as you reach the right entry. Now enter "0" and confirm with "H"  
 Or you delete all entries by setting default values with command P130 and "0" + "H"

## 2.19. Programming Happy-Hour-Credits P140 to P144

For additional attraction of the audience this function is implemented.

At defined times of the week additional free credits (Happy-Hour-credits) are given, depending on the number of paid for credits.

Standard setting is that no Happy-Hour-credits are given.

**P140:** With the program "P140 0+H" all entries of group P14x are set to zero so that there is no happy-hour.

Enter: P 140 H 0 H

*i.e. set default values  
No Happy-Hour:*

P 1 4 0		0
---------	--	---

**P141:** With P141 the starting time is set for the time window happy-hour credits.  
See P080 for key pad layout.

Enter: P 141 H

*Set per pressing keys  
i.e. starting time = 12.34 P.M.  
confirm settings with key "H"*

P 1 4 1		1 2 3 4
---------	--	---------

**P142:** With P141 the stopping time is set for the time window happy-hour credits.  
See P080 for key pad layout.

Enter: P 142 H

*Set per pressing keys  
i.e. stopping time = 13.45 P.M.  
confirm settings with key "H"*

P 1 4 2		1 3 4 5
---------	--	---------

**P143:** With P143 the week-day is set. See P082 for key pad layout.

Enter: P 143 H 0 or 1 H

*Set per pressing keys  
i.e. saturday active:  
confirm settings with key "H"*

P 1 4 3	6	1
---------	---	---

After confirming one day's entry the software steps to the following day.

**P144:** Here a calculated number may be programmed. This number defines how many credits one must have bought to get an additional Happy-Hour-credit.

0+H: no Happy-Hour

n+H: after "n" bought credits (n=1 to 5) 1 additional Happy-Hour-credit is given.

Enter: P 144 H n H

*3 H i.e. after 3 bought credits  
1 additional Happy-Hour-  
credit is given*

P 1 4 4		3
---------	--	---

**Note:** The time window is always active, if all entries in P141, P142, P143 = "0" and P144 is not "0".

## 2.20. Initialization and Test Programs P150 to P159

To help the operator when trouble-shooting or servicing, several functions have been incorporated from earlier phonographs. Group 150 to 159 of the test programs includes functions such as read-out of error memory, various continuous run tests as well as input and display tests. For these purposes, the group code (Fx) is shown in the middle display.

### 2.20.1. Test Programs for Service Operation P150 to P155

#### **P150:** Read-out of Error Memory:

- 0: last registered error; see table 7 for "Error Codes" on the next page.
- 1: previous error; the phonograph records the last 20 error reports.
- 2: CD number during which the error occurred.
- 3: Time of error and
- 4: Date of occurrence

Display:



### 2.20.2. Continuous run tests

With programs P151 to P153 various tests in continuous run mode are executed. A continuous run can only be stopped by using the cabinet switch.

#### **P151:** Plays all CDs for 16 sec. (F1):

Enter: P 151 H 0

Start continuous run 1:

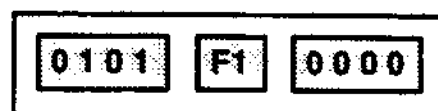

CD / Track      number of errors

#### **P152** Plays selected CDs for 16 sec. (F2):

During CD play another number "nnnn" can be entered (continuous run 2). With each entry "Your Selection" will light up on the display panel.

Enter: P 152 H n n n n H  
(enter a CD-number)

#### **P153** Other Continuous Play Tests (F3 to F5):

Enter: P n

- 0 All CDs are placed on player, but are not played (continuous run 3, F3).
- 1 6 certain CDs (CD No. 1, 25, 50, 51, 75, 00) are placed and played 16 sec. each continually (continuous run 4, F4)
- 2. Combination of twice continuous run 3 followed by 4 until cabinet switch is turned off (continuous run 5, F5)

**P154** This testing routine is reserved for authorized service technicians to check the function of the CD changers opto couplers

#### **P155:** Display Test (F6).

During the display test all digits of the displays and all control lamps are turned on and off. Pressing "H" will stop the test and continue it after pressing "H" again. The display test does not check the lamps of a light organ that might be connected. Pressing "C" stops the test.

Enter: P 155 H  
0. Start lamp test  
(Display 2 shows briefly F6)



Table 7: Error Displays

Displays			Possible Causes	Corrections
1	2	3		
Er	01		EPROM contents (CONTROL-UNIT) disturbed.	Change EPROM (IC2).
Er	10		RAM (CONTROL-UNIT) defective.	Change RAM (IC 5). After that reprogram all program steps.
Er	11		RAM contents (CONTROL-UNIT) short-term disturbance.	No correction necessary; program is reinitialized. Change RAM IC 3 if frequently occurring.
Er	12		RAM battery is empty.	Change RAM (IC 5). After that reprogram all program steps.
Er	20		Verification errors in program (CONTROL UNIT).	No correction necessary; program is reinitialized. Change CPU IC 1 if frequently occurring.
Pxxx	Er	30	Memory contents (CONTROL UNIT) lost or missing.	No correction necessary; program step Pxxx (in display 1) is automatically reprogrammed.
Pxxx	Er	31	Memory contents (CONTROL UNIT) incorrect.	Program step Pxxx shown in display 1 must be reprogrammed.
Pxxx	Er	40	Wrong price setting.	Check price setting and reprogram if necessary.
Er	50		Coin mechanism defective. Too much credit. Coin channel failure.	Check coin mechanism.
Er	6x		Error at CD player.	See Er 60 - Er 63.
Er	60		Connection to the CD-player interrupted. No supply voltage present for decoder board or CD player.	Check connection cables to the decoder board, check fuses.
Er	61		No CD recognized by CD player. No CD in CD tray. CD defective. Player defective.	Check CD and exchange if needed. Exchange CD player. Exchange decoder board.
Er	62		Specified track on the CD not found	Check the CD.
Er	63		Malfunction while playing a CD	Check the CD player with equipped CD for easy running.
Er	64		Connection to CD changer	Check connection cables and control cable to CD changer. Check fuses.
Er	65		No communication between CD changer and CONTROL UNIT	Restart phonograph.
Er	70		Malfunction of operating control	No correction necessary.
Er	71		Malfunction of CD changer	If error display does not disappear after 2 sec., error cannot be automatically corrected. No CD will be played until cabinet switch or "power on" is activated.
	-	74		
Er	71		Error during gnp from magazine	Load CD-tray to magazine. Check alignment from magazine to pickup assy and adjust if necessary. Check function of light barner sGrL and sGrR.
Er	72		Error during replacing CD in magazine Malfunction of gnp lever	Check alignment of magazine to pickup assy and adjust if needed. Check function of gnp. Check function of light barner sGrL and sGrR
Er	73		Malfunction during lift drive Playing of CD not possible	Check lift for jamming. Check function and correct adjustment of light barner Encoder
Er	74		End position of lift not o k Playing of CD not possible	Check function and adjustment of light barner sLift.
Er	80		Short circuit on wallbox signal wire	Check wallbox connection.
Er	81		Malfunction of the audio processor (CB CENTRALEINHEIT)	Change IC 1 = TDA 4390 if frequently occurring.
Er	90		Title display. three jams in sequence. not functional anymore	Un-jam Er 90 to Er 94 are valid only for the "big" title display with 25x4 title strips with CD cover.
Er	91		Jam in title display while left movement.	
Er	92		Jam in title display while right movement.	
Er	93		Jam in title display. stack left.	
Er	94		Jam in title display. stack right	

### 2.20.3. Additional test programs for the service operator

This functions are only allowed to be carried out by authorized service staff, therefore you can find more information only in chapter 3.

#### Test of the Control Unit (Input Test "F7")

**P156:** The input test checks all input ports and shows the results in a matrix on display 3. The test can be stopped by pressing "C". You can find more information only in chapter 3, because this function is only allowed to be carried out by authorized service staff.

#### Checking the adjustment of the CD changer

**P157:** Manual control of CD changer via key pad (F8):

In this test program the CD changer is controlled manually via the keyboard. Several functions are executed by pressing the corresponding key depending on whether a CD is on the laser player or not.

This test serves to check the light barrier in the various positions. You can find more information only in Appendix A: Technical description MBC III, because this function is only allowed to be carried out by authorized service staff.

#### Adjusting of grip-reference

**P158:** This function allows the service operator to set in the adjustment of the grips to the CD-trays via display and keyboard of the phonograph. You can find more information only in Appendix A: Technical description MBC III, because this function is only allowed to be carried out by authorized service staff.

#### Adjusting of the lift-reference

**P159:** This function allows the service operator to set in the adjustment of the lift to the CD-trays via display and keyboard of the phonograph. You can find more information only in Appendix A: Technical description MBC III, because this function is only allowed to be carried out by authorized service staff.

## 2.21. Recording titles into title memory P160 to P163

### P160: Recording title quantities of all CDs

After calling up this command, the phonograph searches through all CD trays in both magazines up to the number of CDs defined in P042. During the search it reads the number of titles recorded on each CD and stores this information into the title memory. This command is to be used after initial loading of CD's or if several CDs are exchanged.

The number of titles on each CD is registered in the title memory. Simultaneously, the CD number and amount of tracks are displayed.

Enter: P 160 H 0

*i.e. result: CD 01 has 24 titles*

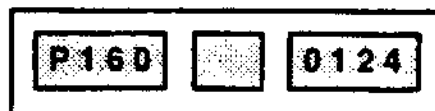

### P161: Initializing of one CD

After calling up this command and entering the number of the newly installed CD, its number of titles is registered in the title memory. The number of titles from each CD is also read with every normal play. This function serves as single entry cancellation, if a not initialized CD is selected.

Enter: P 161 H nn H

*67 H i.e. = CD #67:*

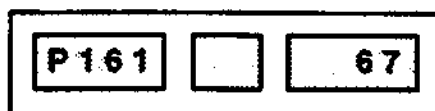

### P162: Read-out all title memories

After calling up this command and entering the code number, the corresponding CD's data will be displayed.

- 0: Number of titles from CD #01
- 1: Switch to the next CD #
- 2: Return to the previous CD #
- 3: Title number of any CD



With P162.3 the two-digit CD number must be entered and confirmed with "H".

### P163: Erasing entry in title memory

All entries in the title memory are set to 1. So all CD titles are cleared, but the phonograph may access any CD tray. If new CDs are loaded and the command P160 is used you may be sure that all new titles are stored in the title memory.

Enter: P 163 H 0 H



**Note:** After removing a CD you also have to remove the corresponding CD cover in the display unit.

## 2.22. Switching signal sources for testing the audio amplifier

**P164:** For test purposes different signal input ports for the 3 intended signal sources can be switched individually. This is done with command P164 by entering different code numbers.

- 0: No signal source active, mute (amplifier turned off)
- 1: CD changer is signal source
- 2: An audio cassette player (tape recorder) is signal source.
- 3: A microphone is signal source.

This "manual" switching occurs automatically in normal play according to the signal source that is turned on.

Enter: P 164 H n H  
           2 H    *i.e. for tape recorder:*

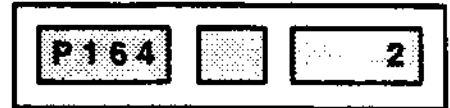

## 2.23. Interface protocol for COM-port (Bacta-interface for GB only)

**P170:** Use this program to switch the protocol and the data transfer rate used for the COM-port of the phonograph.

- 0+H: No protocol for the COM-port
- 1+H: Bacta-protocol
- 2+H: DCL-protocol (DCL = Data Cartridge Loader)
- 3+H: Set data transfer rate to 1200 baud
- 4+H: Set data transfer rate to 2400 baud
- 5+H: Set data transfer rate to 9600 baud
- 6+H: Set data transfer rate to 19200 baud

Enter: P 170 H n H  
           1 H    *i.e. for use BACTA interface:*



The interface protocol has been extended. Now it is possible to output cash contents and coin counters of up to 3 selector wall boxes.

**Note:** To activate the change of the interface protocol you have to power-off and again power-on the phonograph.

2.24. Animation via the title display P180 to 187

**Attention:** The program steps P180 to P187 are not valid for the small title display (3x18). The software automatically determines the type of title display (25x4 or 112 or 104).

To move the CD-covers and the playing instructions placed on title strips inside the title display this group of service program steps were implemented.

At defined times of the week the operator can program that the title strips are moved automatically, e.g. to show advertisement inlets at regular intervals. Of course the title display may be operated manually. **This is the standard mode of operation.**

**P180:** With program "P180 0+H" all entries in group P18x are set to zero and the title display works normal only by pressing the rocker button.

Enter: P 180 H 0 H

*i.e. set default values:  
ONLY MANUAL CONTROL*

P 1 8 0		0
---------	--	---

**P181:** With program P181 the starting time is set for the time window of "Animation via title strips". Key pad layout see P080.

Enter: P 181 H

*Set per pressing keys  
i.e. starting time = 12.34Uhr  
confirm settings with key "H":*

P 1 8 1		1 2 3 4
---------	--	---------

**P182:** With program P182 the stopping time is set for this time window. Key pad layout see P080.

Enter: P 182 H

*Set per pressing keys  
i.e. stopping time = 13.45Uhr  
confirm settings with key "H":*

P 1 8 2		1 3 4 5
---------	--	---------

**P183:** With program P183 the days are set on which animation via title strips should be active. Key pad layout see P082

Enter: P 183 H

*0 or 1 H  
Set per pressing keys  
i.e. monday = inactive:*

P 1 8 3	1	0
---------	---	---

After confirming one day's entry the software steps to the following day.

**P184:** With this program the delay time in minutes is set after which the title strips are moved again:

0+H: no automatical movement of the title strips

n+H: movement after "n" minutes (n = 1 to 99)

Enter: P 184 H nn H

3 H *e.g. move it after 3 minutes:*

P 1 8 4		3
---------	--	---



**P185:** With this program followed by 20 values (nn) you can define 20 target positions for the title display. Always enter the position number of the upper left title strip (e.g. 01, 05, 09, 13, 17, 21, 25, ..., 93, 97).

Enter: P 185 H    nn H  
                   01 H e.g. 1. entry = position 01:



Enter: P            09 H e.g. 2. entry = position 09:  
                           and  
                           so  
                           on.



Up to 20 entries always confirmed by pressing "H".

Clear erroneous input by pressing key "C" **once**  
 Early termination is possible by pressing key "C" **twice**.

**P186:** With this program you define:  
 0+H: continually movement of title strips in Stand-by for one position or to the next programmed position.  
 1+H: single movement in Stand-by to the next programmed position.  
 2+H: continually movement of title strips for one position or to the next programmed position.  
 3+H: single movement to the next programmed position.

Enter: P 186 H    n H  
                       2 H e.g. continually movement:

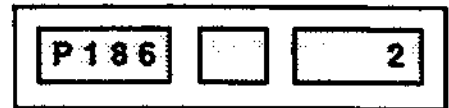

**P187** Limitation of the position of the title display corresponding to the numbers of inserted CDs:

0+H: Number of title strips is equal the number of CDs programmed in P042.  
 n+H: Enter number "n" of unused positions of the title display.

Enter: P 187 H    n H  
                       0 H e.g. number of titles strips=  
                                   number of CDs:

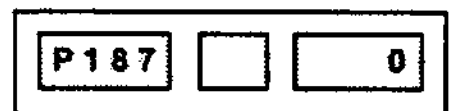

**Note:** The time window is always active, if all entries in P181, P182, P183 and P184 is not = "0".

# Section 3

### 3. Section

#### 3.1. Maintenance and Service for the NSM phonograph GEMFIRE

#### 3.2. Cleaning the housing of the phonograph

Clean housing using a soft and damp leather rag.

Clean the glasses (front glass) of the phonograph using a solvent-free window cleaner.

**Attention!** Clean the upper and inner plastic glasses using only a soft damp rag.

**Avoid using any chemicals for cleaning the phonograph! Plastic parts of the phonograph could be damaged.**

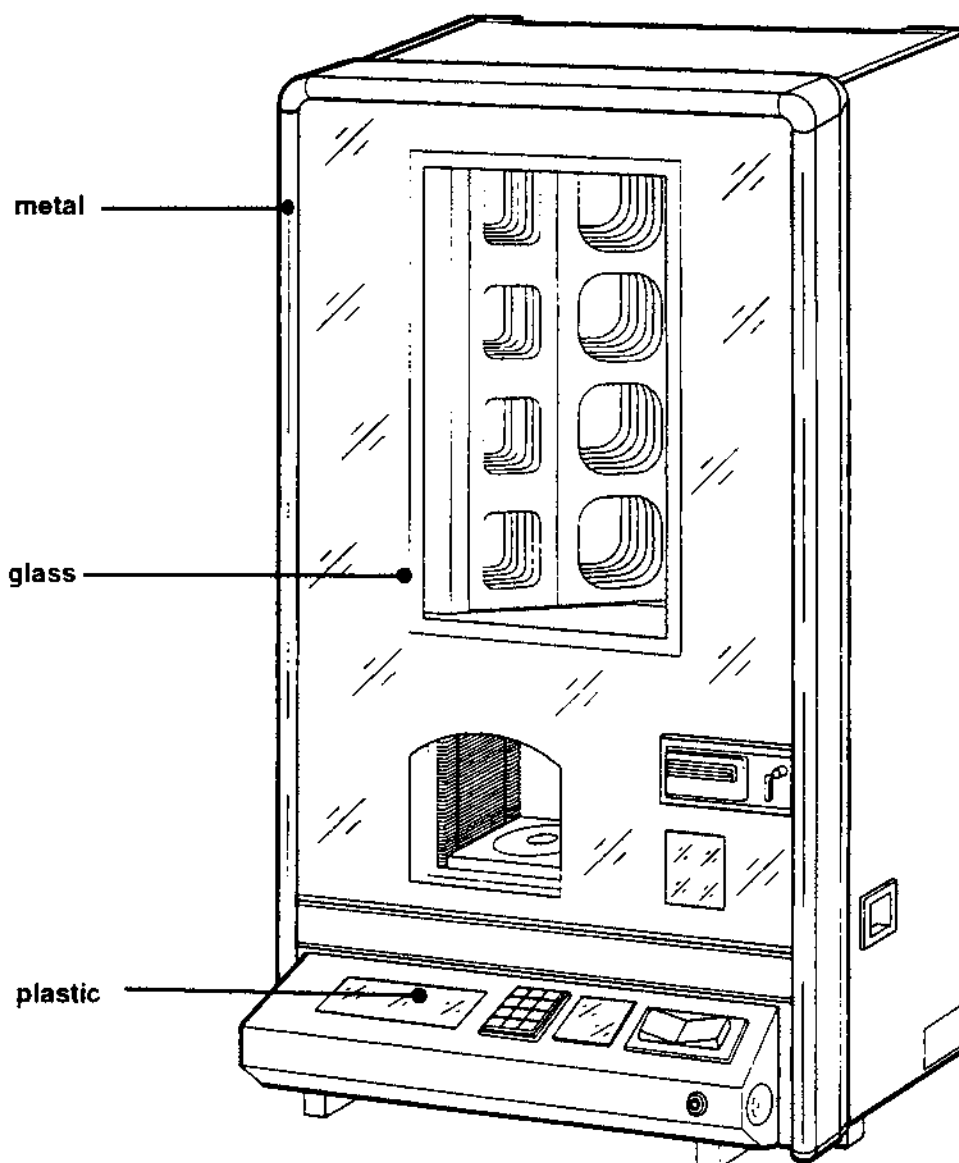

Figure 36: Cleaning of the phonograph

### 3.3. Cleaning the inside of the phonograph

Besides the outside cleaning of the phonograph, the inside has to be cleaned according to the degree of pollution once or twice a year with the help of a vacuum cleaner.

### 3.4. Cleaning the title display unit

The title display unit should be cleaned using a soft damp rag. Be careful that the title holders do not fall out of their leading if you press too much against it.

### 3.5. Replacing fluorescent lamps, starters and 12V-lamps

There are four fluorescent lamps 16W in the phonograph.

**For replacing the lamps or starters: Power-off the phonograph and open the front door.**

1. Unplug power cord and open the phonograph's door.
2. The fluorescent lamps and starters are located all at the inner side of the door.
3. The 12V lamps are located on the CB Display in the operators console and on the electronics cover and beneath the dollar bill chute.
4. Replace the defective lamp or starter.

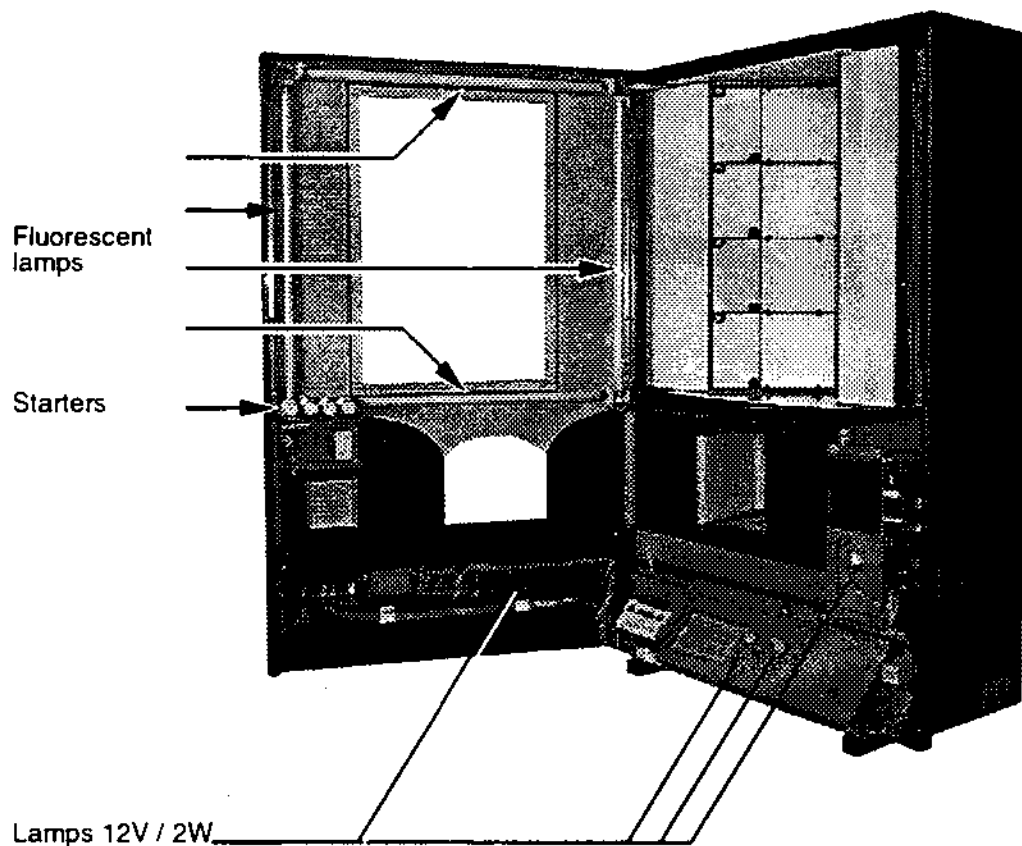

Figure 37: Replacing fluorescent lamps

### 3.6. Trouble-shooting for ES V / ES5.1- CD-technology

#### 3.6.1. Error description

The following table gives you first hints on the possible causes of a malfunctioning of the phonograph.

Table 8: Possible error causes

Error description	Possible error cause
Phonograph illumination and LED's in CB CENTRALEINHEIT ES5.1 do not light up.	<ol style="list-style-type: none"> <li>1. Power cord</li> <li>2. Main switch</li> <li>3. Power fuse (switch plate/fuse box)</li> </ol>
Phonograph illumination okay but LEDs in CB CENTRALEINHEIT ES5.1 do no light up.	<ol style="list-style-type: none"> <li>1. Plug connection ST 1 of CB CENTRALEINHEIT ES5.1</li> <li>2. Fuses Si 1-5 of CB CENTRALEINHEIT ES5.1</li> <li>3. Power transformer connection</li> </ol>
Fan for output stage does not run while disc is playing.	<ol style="list-style-type: none"> <li>1. Plug connection ST 4</li> <li>2. Triac TC 1.</li> <li>3. Transistor T2 / T1.</li> </ol>
LED's in CB CENTRALEINHEIT ES5.1 do not light up or appear too dark. Fuses are okay.	<ol style="list-style-type: none"> <li>1. Voltage regulators VR 1-6 in CB CENTRALEINHEIT ES5.1 defective</li> <li>2. Short circuit in connected units. (Pull plugs one after another and observe LED's).</li> </ol>
No tone signal at loudspeaker even though a CD is playing and volume is given.	<ol style="list-style-type: none"> <li>1. Loudspeaker connection</li> <li>2. Plug connection of frequency volume and of output transformer</li> <li>3. Interruption of signal wire</li> </ol>
Volume reduced by electronic protection device in CB CONTROL UNIT.	<ol style="list-style-type: none"> <li>1. Loudspeaker mismatch (less than 2 Ω impedance) due to remote speakers.</li> <li>2. Transistor T 9 defective.</li> <li>3. Output transistor defective.</li> <li>4. CB CONTROL UNIT defective.</li> </ol>
Poor bass reproduction.	<ol style="list-style-type: none"> <li>1. Loudspeaker connections reversed.</li> </ol>
Phonograph operators display shows error message as: Er xx	See table 2: "Possible error messages".

3.6.2. Error flow chart

Conditions: Line voltage present, line connection and power supply in order.

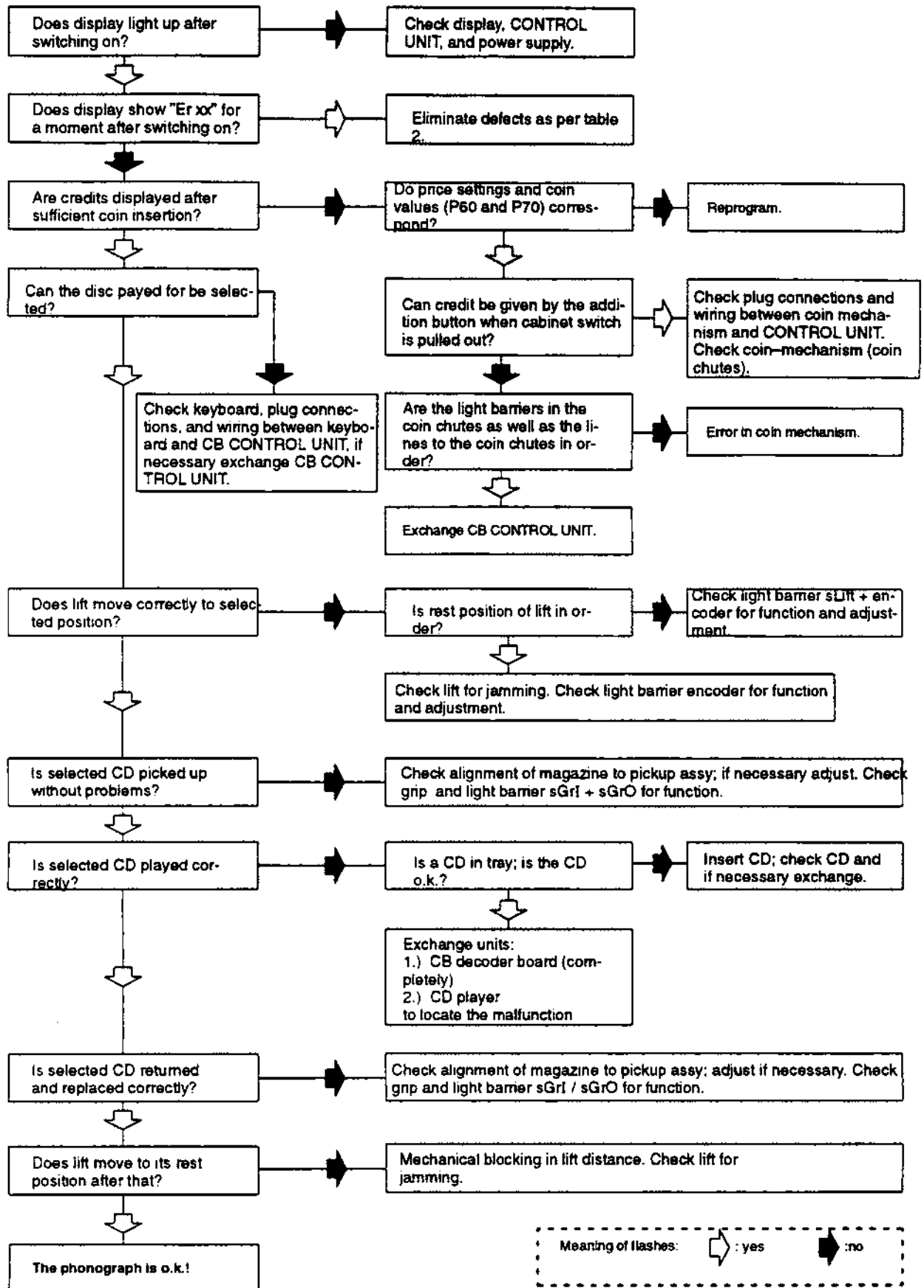

### 3.6.3. Error display / table of error messages

After power on the phonograph, respectively after terminating the service program, the microprocessor in the CB CONTROL UNIT checks all memorized values.

If any error is detected a corresponding error message appears on displays 2 and 3 for information, e.g. "Er 31" (31= error number). Additionally the lamp "error" flashes, and the corresponding command number appears on display 1.

In this case correct the necessary input in the service mode. After input of the correct value and pressing the key "H" this error is cleared.

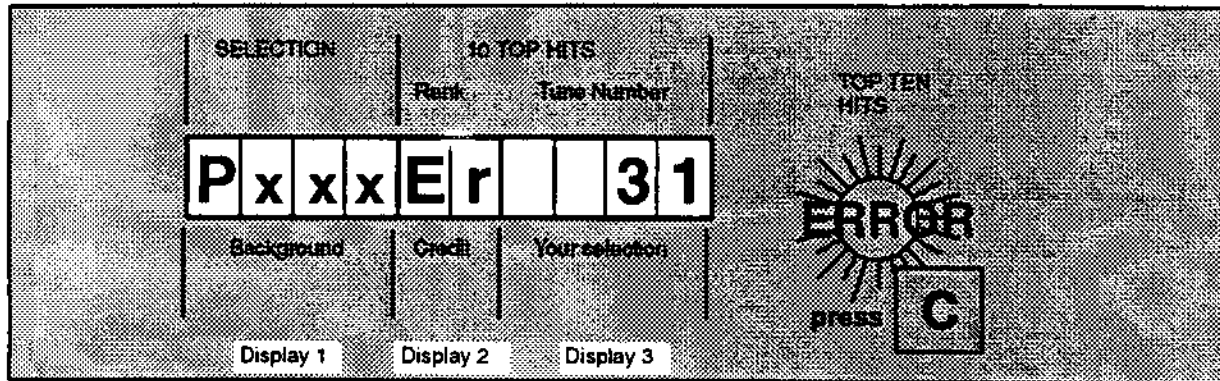

Figure 38: Display of the phonograph in malfunction case

After power on the phonograph, the malfunction display on display 3 and the flashing lamp "error" remain visible for about 2 seconds. Hereafter the phonograph returns to operation mode without considering the malfunctioning part.

### 3.6.4. Read out the error memory

The group 15x of the test programs includes functions such as read-out of error memory, various continuous run tests as well as input and display tests. For these purposes, the group code (Fx) is shown in the middle display.

Use programm step P150 to read out the last 20 error reports with date, time and CD number of occurrence.

**P150:** Read-out of error memory:

- 0: last registered error; see table 9: "Error Codes" on the next page.
- 1: previous error; the phonograph records the last 20 error reports.
- 2: CD number during which the error occurred.
- 3: Time of error
- 4: Date of occurrence

Example

Display:



In table 9 you will find all possible error displays with the corresponding notices for causes and corrections.

Table 9: Possible error messages

Displays			Possible Causes	Corrections
1	2	3		
	Er	01	EPROM—contents (CONTROL—UNIT) disturbed.	Change EPROM (IC2).
	Er	10	RAM (CONTROL—UNIT) defective.	Change RAM (IC3). After that repeat all program steps.
	Er	11	RAM—contents (CONTROL—UNIT) short—term disturbance.	No correction necessary; program is reinitialized. Change RAM IC 3 if frequently occurring.
	Er	12	RAM—battery is empty.	Change RAM (IC3). After that repeat all program steps.
	Er	20	Verification errors in program (CONTROL UNIT)	No correction necessary; program is reinitialized. Change CPU IC 1 if frequently occurring.
Pxxx	Er	30	Memory contents (CONTROL—UNIT) invalid.	No correction necessary; the displayed command is automatically reprogrammed.
Pxxx	Er	31	Memory contents (CONTROL—UNIT) invalid or not programmed.	Execute displayed command, program new values.
Pxxx	Er	40	Wrong price setting.	Check price setting and reprogram if necessary.
	Er	50	Coin mechanism defective, too much credit.	Check coin mechanism.
	Er	60	Connection to the CD—player interrupted. No supply voltage present for decoder board or CD player.	Check connection cables to the CD player.
	Er	61	No CD recognized by CD player. No CD in CD tray, player defective.	Check CD and exchange if necessary. Exchange CD player.
	Er	62	Specified track on the CD not found.	Check CD.
	Er	63	Malfunction while playing a CD. CD defective	Check CD.
	Er	64	Contact to CD changer interrupted.	Check connection to changer. Replace CD changer or control unit.
	Er	65	No communication between CD changer and CONTROL UNIT.	Restart phonograph.

Continuation next page



Display			Possible Causes	Corrections
1	2	3		
	Er	70	Malfunction of operating control.	No correction necessary.
	Er	71 - 74	Malfunction of CD changer.	If error display does not disappear after 2 sec., error cannot be automatically corrected. No CD will be played until cabinet switch or "power in" is activated.
	Er	71	Error during grip from magazine (left or right).	Equip CD-magazine with tray. Check alignment from magazine to pickup assy and adjust if necessary. Check grip lever for function. Check function of light barriers sGrI and sGrO.
	Er	72	Error during replacing CD in magazine.	Check alignment of magazine to pickup assy and adjust if needed. Check function of grip. Check function of light barriers sGrI and sGrO.
	Er	73	Malfunction during lift drive, playing CD not possible.	Check lift for jamming. Check function and correct adjustment of light barrier sLift and encoder.
	Er	74	Lift cannot synchronize, playing CD not possible.	Check function and adjustment of light barrier sLift and encoder.
	Er	80	Short circuit on wallbox signal wire.	Check wallbox connection.
	Er	81	Malfunction of the audio processor (CB-CENTRALEINHEIT ES5.1).	Change IC 1 = TDA 4390 if frequently occurring.
	Er	90	Title display, not functional anymore (three blockings in sequence).	Unjam. 112er = no more move possible
	Er	91	Blocking title display while left movement.	
	Er	92	Blocking title display while right movement.	
	Er	93	Blocking title display, left stack.	
	Er	94	Blocking title display, right stack.	

### 3.7. Continuous run tests

With programs P151 to P153 various tests in continuous run mode are executed. A continuous run can only be stopped by closing the service switch (i.e. with closing the cabinet).

**P151:** Plays all CDs for 16 sec. (F1):

Enter: *P 151 H 0*

Start continuous run 1:

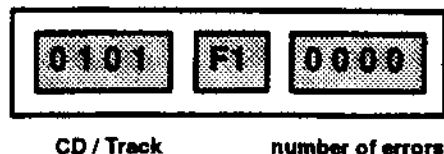

**P152:** Plays selected CDs for 16 sec. (F2):

During CD play another number "nnnn" can be entered (continuous run 2). With each entry "Your Selection" will light up on the display panel.

Enter: *P 152 H n n n n H*

(enter one or more CD-numbers)



**P153:** Other Continuous Play Tests (F3 to F5):

Enter: *P n*

- 0: All CDs are placed on player, but are not played (continuous run 3, F3).
- 1: 6 distinct CDs (CD No. 1, 25, 50, 51, 75, 00) are placed and played 16 sec. each continually (continuous run 4, F4)
- 2: Combination of twice continuous run 3 followed by 4 until cabinet switch is turned off (continuous run 5, F5).



#### 3.7.1. Testing the phonograph illumination and display elements

**P155:** Display Test (F6):

During the display test all digits of the displays and all control lamps are turned on and off. Pressing "H" will stop the test and continue it after pressing "H" again. The display test does not check the lamps of a light organ that might be connected.

Pressing "C" stops the test.

Enter: *P 155 H*

- 0: Start lamp test  
(Display 2 shows briefly F6)



### **3.8. Additional test programs for the service operator**

With the programs P156 to P159 you can call additional test routines. They are described in their corresponding chapter.

**P156**: Test of the Control Unit (Input and Output interfaces), see chapter 3.12 .

**P157**: Manual control of CD changer and opto status, see appendix A.

**P158**: Adjustment of grip-reference, see appendix A.

**P159**: Adjustment of the lift-reference, see appendix A.

### **3.9. The phonograph GEMFIRE**

#### **3.9.1. Operating scheme**

The following page contains the operating scheme of the phonograph GEMFIRE

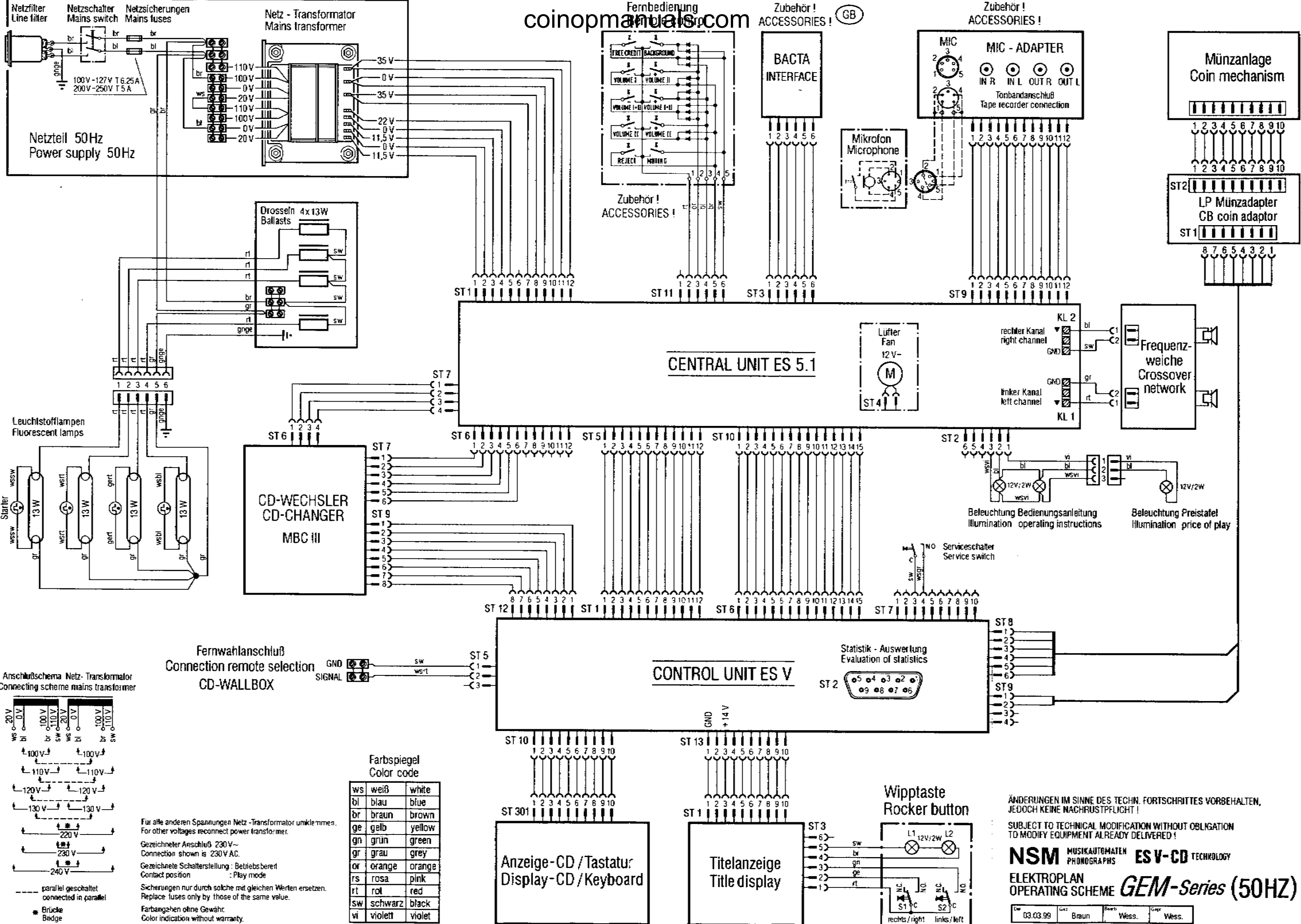

Anschlußschema Netz- Transformator  
Connecting scheme mains transformer

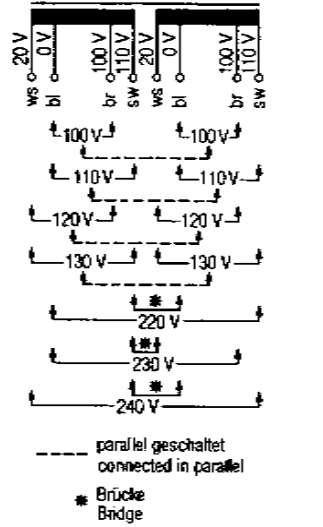

Für alle anderen Spannungen Netz -Transformator umklemmen.  
For other voltages reconnect power transformer.

Gezeichneter Anschluß 230 V~  
Connection shown is 230 V AC.

Gezeichnete Schalterstellung : Betriebsbereit  
Contact position : Play mode

Sicherungen nur durch solche mit gleichen Werten ersetzen.  
Replace fuses only by those of the same value.

Farbangeben ohne Gewähr.  
Color indication without warranty.

Farb Spiegel  
Color code

ws	weiß	white
bl	blau	blue
br	braun	brown
ge	gelb	yellow
gn	grün	green
gr	grau	grey
or	orange	orange
rs	rosa	pink
rt	rot	red
sw	schwarz	black
vi	violett	violet

ÄNDERUNGEN IM SINNE DES TECHN. FORTSCHRITTES VORBEHALTEN,  
JEDOCH KEINE NACHRÜSTPFLICHT!

SUBJECT TO TECHNICAL MODIFICATION WITHOUT OBLIGATION  
TO MODIFY EQUIPMENT ALREADY DELIVERED!

**NSM** MUSIKAUTOMATEN PHONOGRAPHS **ES V-CD** TECHNOLOGY

**ELEKTROPLAN**  
OPERATING SCHEME **GEM-Series (50HZ)**

Drw 03.03.99 Gw2 Braun Bschb Wess. Ggr Wess.

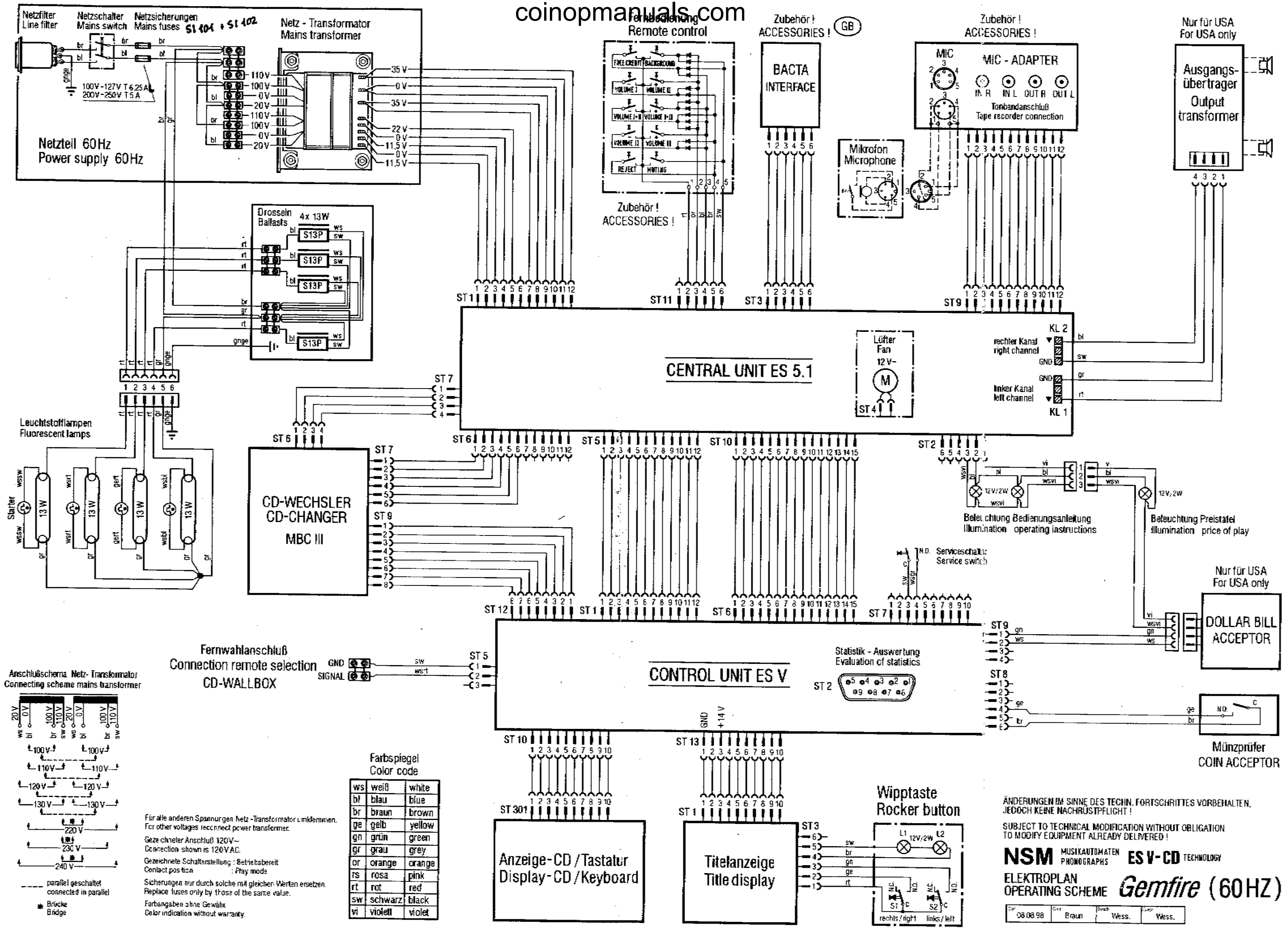

Anschlussschema Netz-Transformator  
Connecting scheme mains transformer

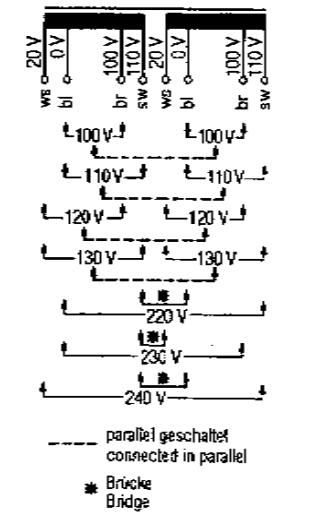

Für alle anderen Spannungen Netz-Transformator umklemmen.  
For other voltages reconnect power transformer.  
Gezeichnete Anschluß 120V-Connection shown is 120VAC.  
Gezeichnete Schalterstellung: Betriebsbereit  
Contact position: Play mode  
Sicherungen nur durch solche mit gleichen Werten ersetzen.  
Replace fuses only by those of the same value.  
Farbangaben ohne Gewähr  
Color indication without warranty.

Farbspiegel  
Color code

ws	weiß	white
bl	blau	blue
br	braun	brown
ge	gelb	yellow
gn	grün	green
gr	grau	grey
or	orange	orange
rs	rosa	pink
rt	rot	red
sw	schwarz	black
vi	violett	violet

ÄNDERUNGEN IM SINNE DES TECHN. FORTSCHRITTES VORBEHALTEN, JEDOCH KEINE NACHRÜSTPFLICHT!  
SUBJECT TO TECHNICAL MODIFICATION WITHOUT OBLIGATION TO MODIFY EQUIPMENT ALREADY DELIVERED!  
**NSM** MUSIKAUTOMATEN PHONOGRAPHS **ES V-CD** TECHNOLOGY  
**ELEKTROPLAN OPERATING SCHEME Gemfire (60HZ)**  
08.08.98 Braun Weiss Weiss

Part-No.	Description	Data
----------	-------------	------

**Cable harnesses**

227 528	Power cord	
179 777	Mains plug – Transformer	
177 786	Mains transformer	
179 779	Transformer – Ballast	
179 778	Ballasts 60 Hz	
179 687	Illumination decor frame	
179 781	Illumination keyboard	
179 559	Illumination playing instruction	
179 780	Service switch	
178 369	Volume control button	
178 012	Control Unit – Title display	
179 749	Title display – Rocker button	
179 784	Control Unit – DISPLAY	

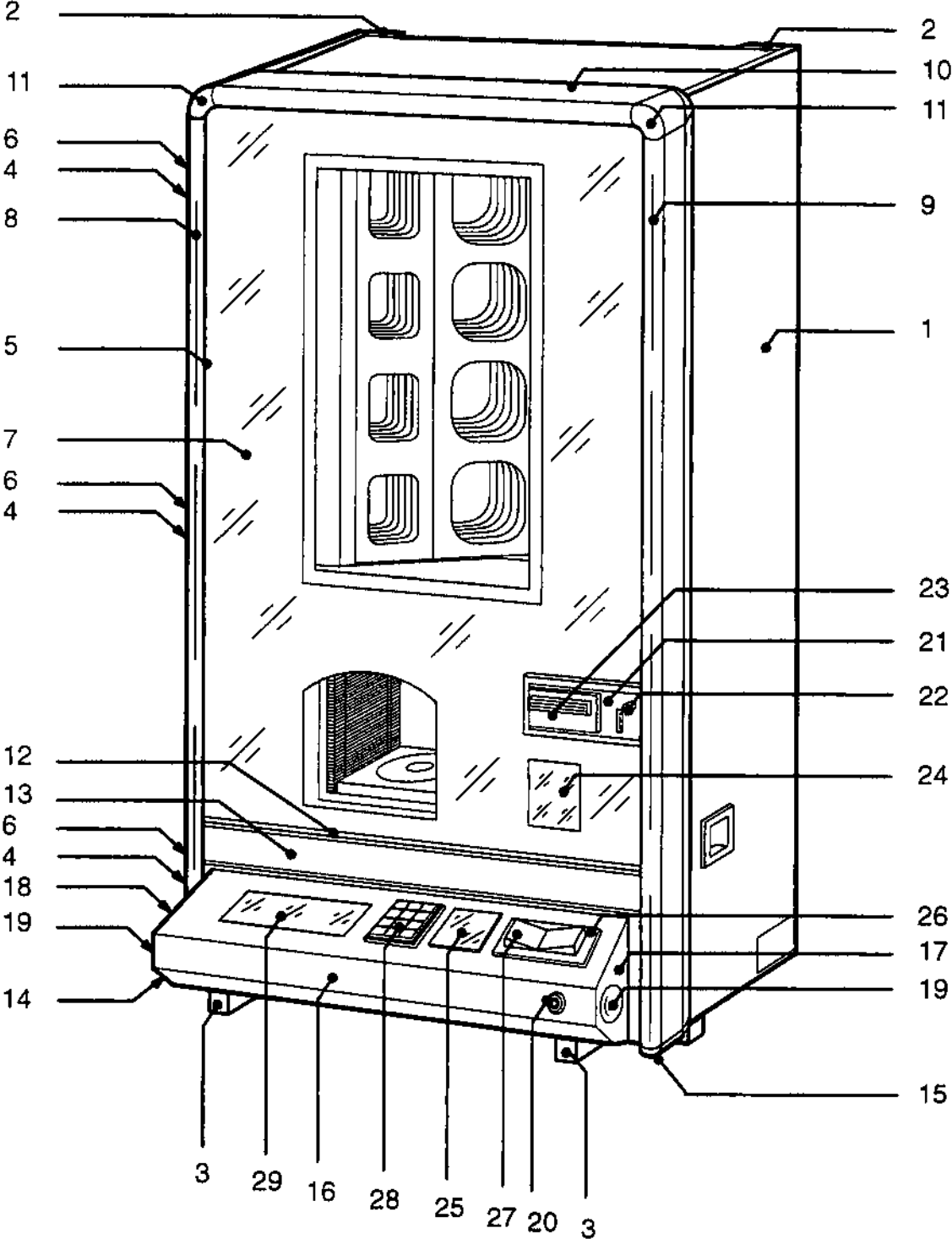



Pos.	Part-No.	Description	Data	Quantity
Spare parts for NSM phonograph GEMFIRE:				
1	179 641	Cabinet, spot welded	black	1
2	179 553	Stopper, top		2
3	179 539	Cabinet foot		2
4	113 326	Hinge, lower part		3
5	179 560	Decor frame, complete	*USA*	1
6	250 457	Hinge, upper part		3
7	160 141	Front glass	*GEMFIRE*	1
	217 507	Rubber profile	(2x0,78m; 2x0,6m)	1
8	250 526	Frame left	red	1
9	250 527	Frame right	red	1
10	250 258	Frame up	red	1
11	119 635	Edge connector, top		2
12	250 529	Cross profile, bottom		1
13	239 360	Cross profile cover	self-adhesive	1
14	121 367	End connector left		1
15	121 368	End connector right		1
16	179 588	Pult-plate	black	1
17	179 537	Pult-cover right		1
18	179 538	Pult-cover left		1
19	179 683	Decor plate, small		2
20	206 903	Lock	type 3293-13 FG 3/16	1
	179 593	Locking lever		1
21	179 197	Coin return lever		1
	205 683	Pressure spring		1
	179 551	Frame	*USA*	1
23	216 501	Dollar Bill Acceptor, complete		1
24	179 595	Playing instruction	*USA*	1
25	179 382	Plate printed "Operating instructions"		1
26	176 574	Frame for rocker button		1
27	175 974	Rocker button		1
28	176 671	Keyboard red/blue	12-keyboard	1
29	178 955	Plate printed	for Display	1

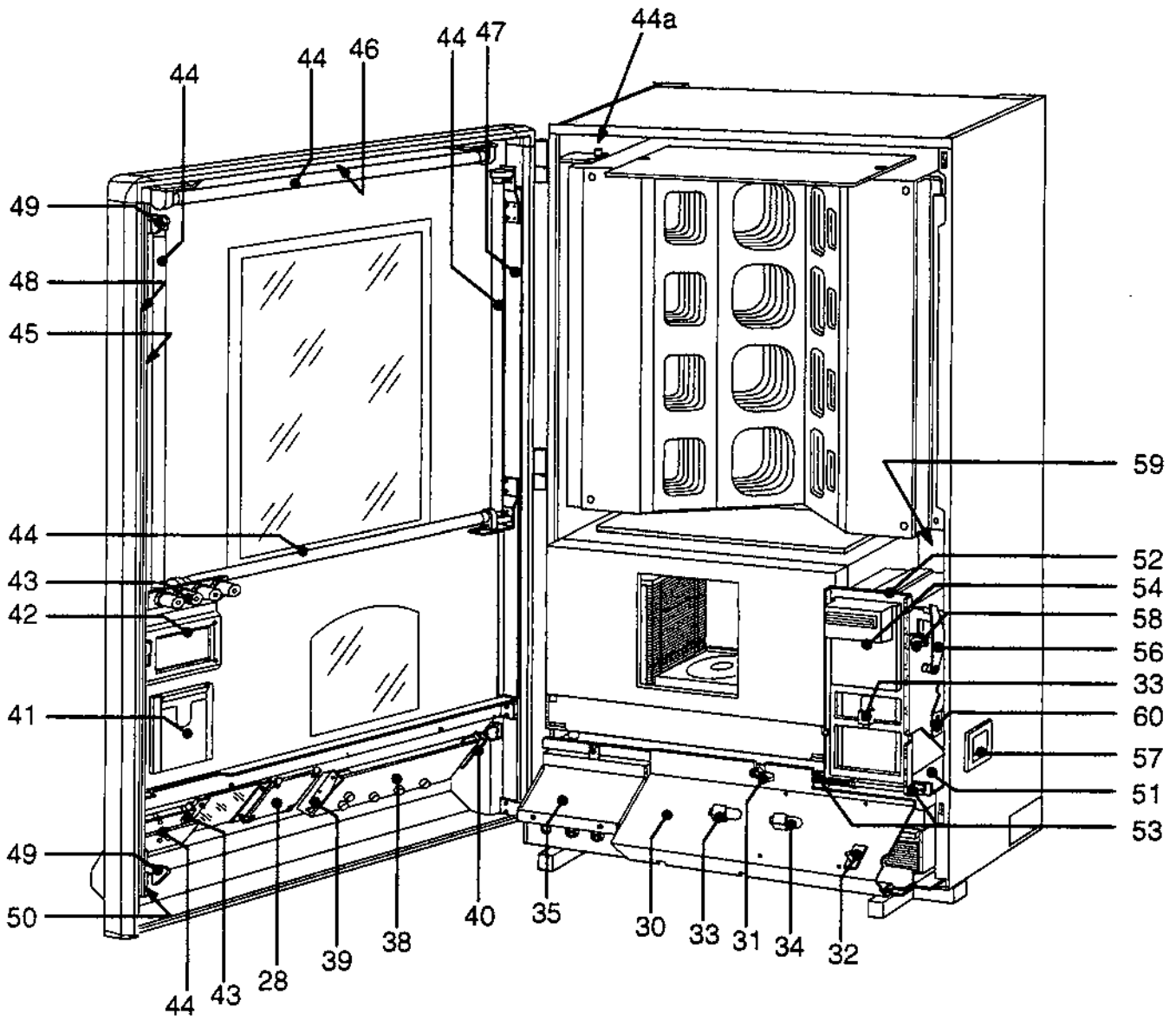

Pos.	Part-No.	Description	Data	Quantity
Spare parts for NSM phonograph GEMFIRE continued:				
30	179 748	Cover, pointed, for electronics compartment		1
	171 629	Holder for cover		2
31	108 575	Locking knob		1
32	222 509	Service switch		1
33	225 587	Lamp socket		2
34	226 056	Lamp	12-15V / 2W	2
35	179 568	<b>Power supply 60 Hz, complete</b>		1
36	179 636	Transformer housing, pointed		1
	223 465	Mains transformer		1
	225 985	Noise suppression		1
	222 574	Power-on switch (Mains switch)		1
	235 135	G-Fuse holder		2
	225 218	G-Fuse	6,25A / 250V	2
	235 138	Cap	60Hz	2
37	179 639	Cover for transformer housing		1
38	173 664	<b>CB DISPLAY-CD</b>	see chapter 3.13	
	171 629	Holder, red		4
39	171 714	Catch spring left		1
40	171 626	Catch spring right		1
41	179 283	Holder for playing instruction		1
	179 595	Playing instruction	*USA*	1
42	179 807	Mounting bracket, spot welded		1
43	225 040	Starter for fluorescent lamp	S10	4
44	226 075	Fluorescent lamp white	TL13W/33	4
44a	224 254	Ballast for fluorescent lamp		4
45	179 746	Front glass holder left, spot welded		1
46	179 737	Front glass holder upper, spot welded		1
47	179 597	Front glass holder right, riveted and spot welded		1
48	179 627	Locking bar		1
49	179 629	Locking hook		2
50	179 630	Locking lever		1
	205 582	Tension spring		1
51	179 727	Mounting plate		1
52		Holding plate for coin mechanism		1
53	179 657	Bearing		1
54	216 501	Dollar Bill Acceptor		1
55	216 675	Coin acceptor, mechanical (MP 25c)	*USA*	1
56	179 653	Coin return lever		1
57	179 664	Coin return cup		1
58	178 043	Sleeve	white 20mm	1
59	179 660	Cash box, metal, spot welded		1
	179 573	Joining piece cash box/ coin return cup		1
60		Locking lever for Coin mechanism		1

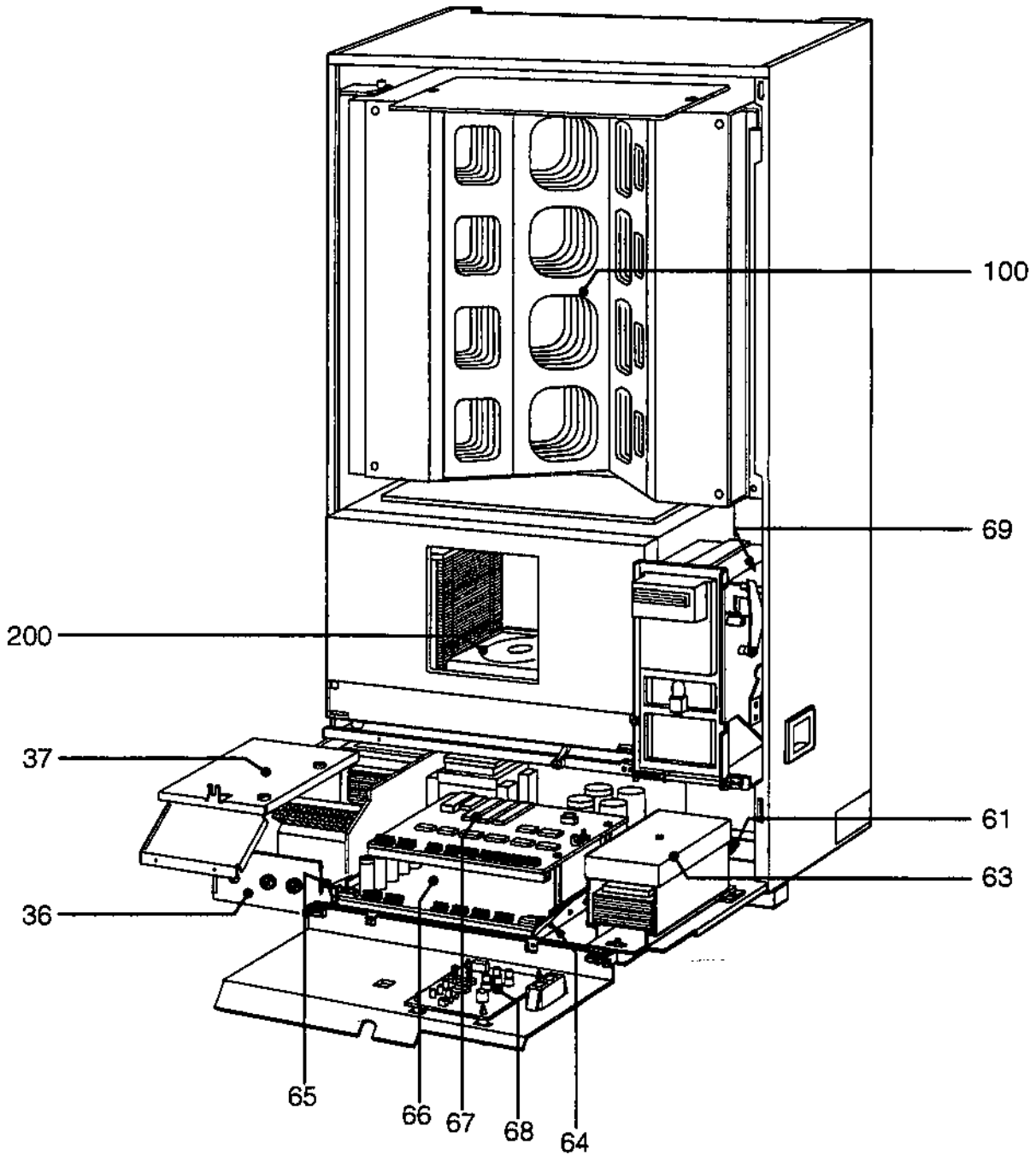

Pos.	Part-No.	Description	Data	Quantity
Spare parts for NSM phonograph GEMFIRE continued:				
61	179 742	Push button plate	(Reject & Volume)	1
	222 452	Push button red		1
	222 470	Push button green		1
	222 471	Push button white		1
62	179 576	Mounting plate for electronics		1
63	179 740	Output transformer		1
64	171 626	Catch spring, right		1
65	171 714	Catch spring, left		1
66	178 973	<b>CENTRAL UNIT ES5.1 – 60Hz</b>	see chapter 3.11	
67	178 239*	<b>CONTROL UNIT ESV–MBCIII</b>	see chapter 3.12	
68	177 465	<b>MIC–Adaptor</b>	see Appendix B	
69	222 602	Micro switch for mechanical coin acceptor	*USA* MP25c	1
	179 801	Actuator for micro switch		1
70	179 540	<b>Title display unit 104</b>	see chapter 3.10	
71	179 155	<b>CD–changer MBCIII–PRO</b>	see Appendix A	

### 3.10. Cleaning of the 104–title display unit

The 104–title display unit in the Gemfire should be cleaned using a soft damp rag. Be careful that the title holders do not fall out of their leading if you press to much against it.

#### 3.10.1. Removing the title display unit

1. Unplug power cord and open the phonograph.
2. Swing out the front door.
3. Take the title display unit (1) with both hands, lift it a little and swing out to the left position.
4. Now hold it and unplug the cable connections at its left hand side (2).
5. Afterwards undertake it with both hands, lift it up and take it out of the left hand hinge (3, 4).

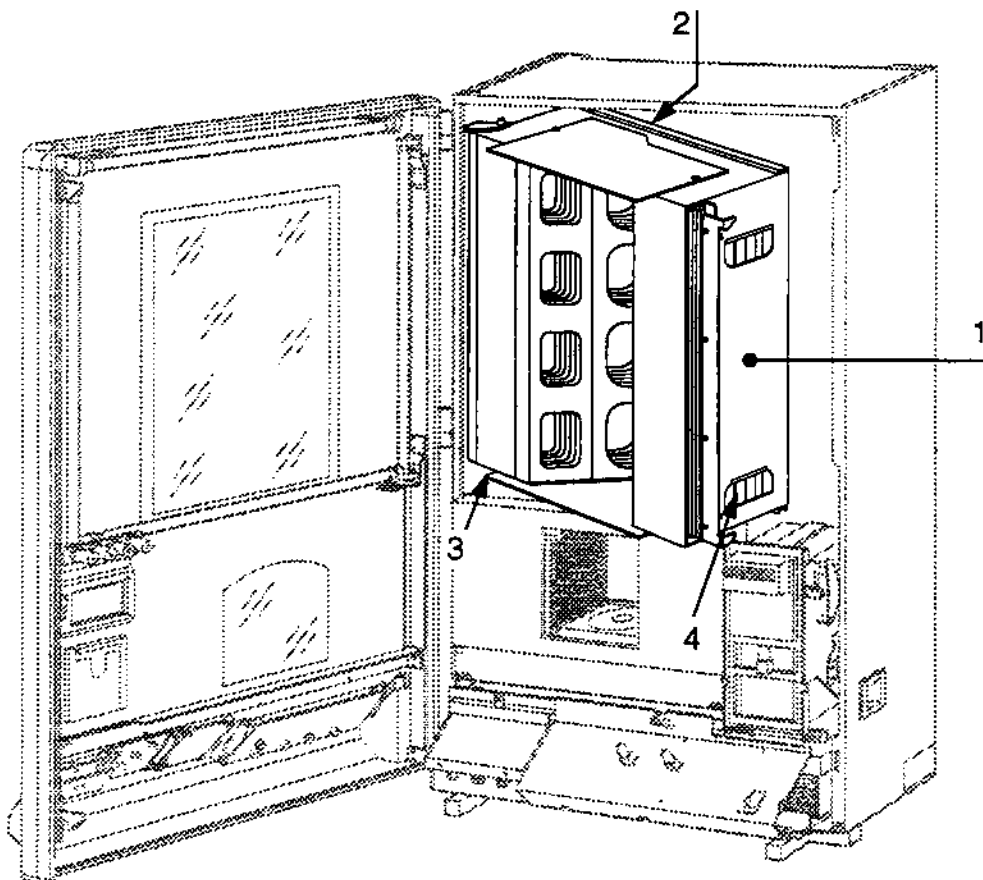

Figure 39: Removing the title display unit

The insertion of the title display is done in reverse sequence.

#### 3.10.2. Greasing parts of the title display after repair

In normal operation it is not necessary to grease parts of the title display. Only in case of occuring repairs it can be necessary to grease newly inserted spare parts to avoid future mal–function.

In that case we recommend to use the following grease: ISOFLEX TOPAS AK 50

This grease can be ordered with our spare parts number: 509 006

**Attention:** Do not use type of grease different from the one defined by the manufacturer of this phonograph. In case of damage you will loose every single warranty claim.

The following pages contain the necessary spare parts list for this title display unit.



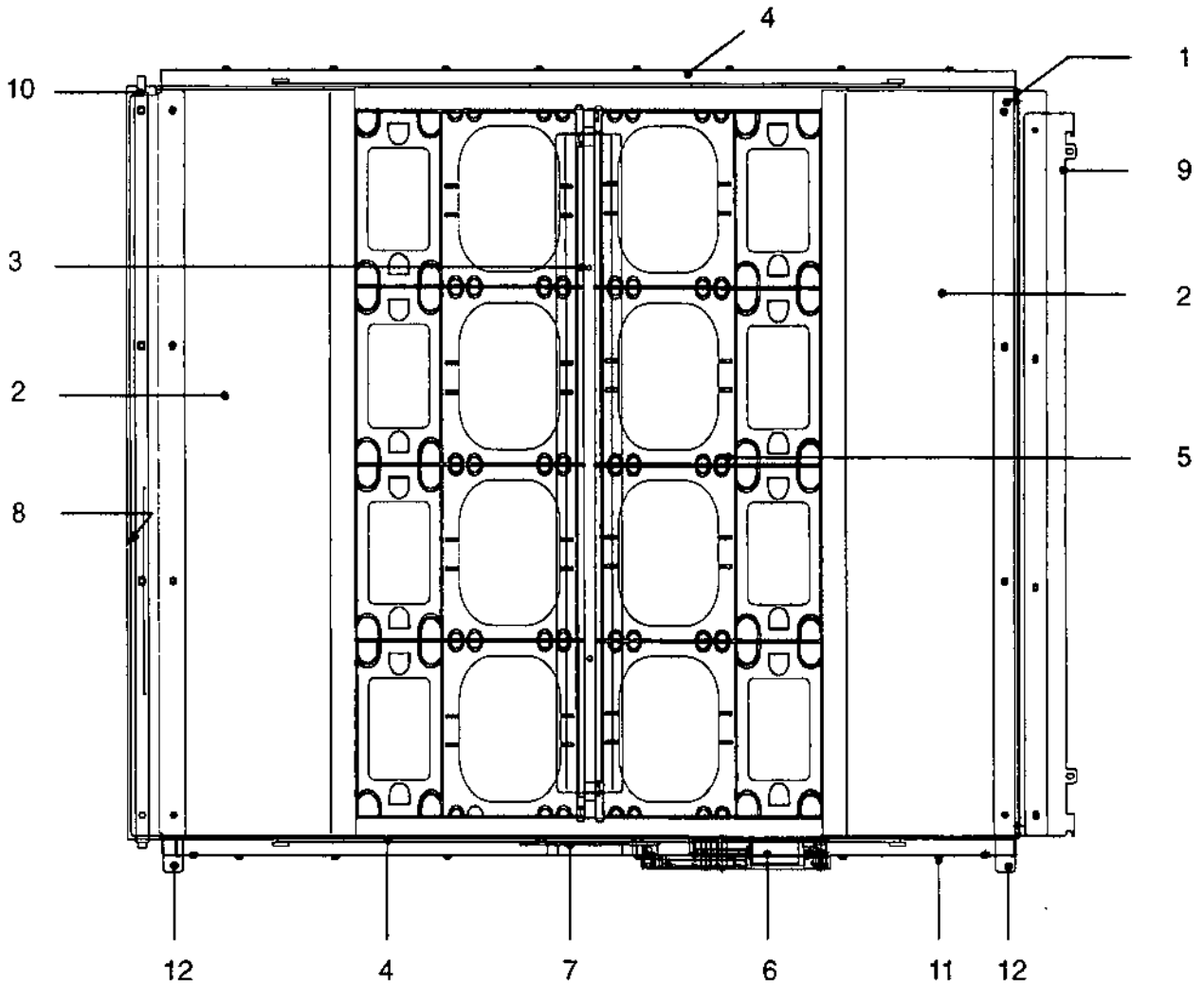



Pos	Part-No.	Description	Data	Quantity
	<b>179 540</b>	<b>Title display 104, complete</b>		<b>1</b>
<b>1</b>	<b>179 541</b>	<b>Cabinet, complete, w/o design parts</b>		<b>1</b>
	217 479	Edge protection, black	4 x 0,102m	
	206 414	Edge protection, DX2	2 x 0,155m for lower handle	
2	179 792	Decoration mask, white		2
3	179 688	Decor mask, black		1
4	212 967	Cover mask, white		2
5	179 225	Title holder		14
	219 861	Adhesive sticker	00-99	1
<b>6</b>	<b>179 542</b>	<b>Gear, premounted</b>		<b>1</b>
	179 702	Cover plate for gear, riveted		1
	179 544	Toothed wheel double	z=69, z=15	1
	179 545	Toothed wheel	z=23	1
	179 707	Motor, complete		1
	116 365	Step bearing		1
	173 432	Worm gear		1
	205 568	Tension spring		1
7	179 709	CB – Opto, complete		1
	231 322	Opto coupler	LTH-301A-N	3
8	179 708	CB – Title display	see following page	1
	229 157	Spacer		4
9	179 718	Clamping bracket		1
10	211 785	Bar with projection		1
11	179 549	Guiding		16
12	179 238	Foot, long		2

Pos.	Part-No.	Description	Data	Quantity
	<b>179 708</b>	<b>CB-Title display 104, complete</b>		<b>1</b>
ST3	225 992	Pin plug	6 poles red standing	1
ST1	225 440	Plug connector	10 poles	1
ST7	225 873	Sub-connector AMP-Micro-Match	10 poles	1
IC2	231 805	IC-Motor-driver	L6202	1
IC1	221 771	IC-Logic	HEF4094B	1
IC3	221 763	IC-Logic	HEF4021B	1
T1	221 459	Si-Transistor	PNP BC556B	1
T2,T3	221 492	Si-Transistor	NPN BC517	2
D1,D2	231 863	Si-Diode	UF4004	2
D3	221 114	Si-Diode	1N4148	1
D5	221 115	Si-Diode	1N4004	1
R27	221 620	Resistance	22Ω 0,34W	1
R31	221 600	Resistance	100Ω 0,34W	1
R14	221 098	Resistance	390Ω 0,34W	1
	221 049	Resistance	470Ω 0,34W	1
R28-30,				
R36,37	221 033	Resistance	3,3KΩ 0,34W	5
R10-13	221 035	Resistance	10KΩ 0,34W	4
R17-26,				
R38,39	221 604	Resistance	22KΩ 0,34W	12
R1-5	221 038	Resistance	47KΩ 0,34W	5
R32,34	221 273	Resistance	10Ω 0,5W	2
R33	231 139	Metox-Resistance	1,2Ω 0,5W	1
C11,12	220 344	Ceramic capacitor	0,022μF 63V	2
C3-10	220 481	Ceramic capacitor	0,1μF 63V	8
C13	220 334	MKT-capacitor	0,1μF 63V	1
C1,2	220 162	Electrolytic-capacitor	10μF 63V	2
C14	220 391	Electrolytic-capacitor	220 μF 25V	1

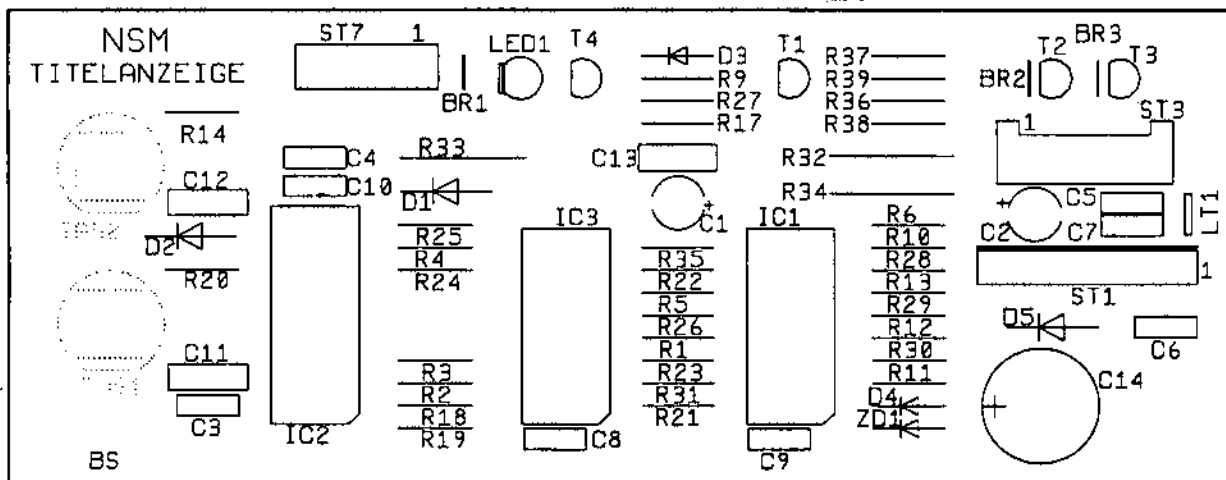

### 3.11. Functional description of the CB CENTRAL UNIT ES5.1

The power supply, stereo amplifier, and output stage are all integrated in the circuit board "CENTRAL UNIT ES 5.1".

The music power per channel is 200 Watt when matched to loudspeakers having an impedance of 4 Ω. The sinus (RMS) power is 125 Watt per channel with a klirrfactor of max 1%.

#### 3.11.1. Power supply

The power transformer supplies 22 V, 2x11,5 V and 2x35 V from three separate secondary coils.

The following supply voltages are generated by the 22 V:

- the supply voltages for VR1 ( $V_3 = +15$  V), VR2 ( $+V_A = +15$  V) and  $V_4 = +28$ V by a bridge rectifier D2–D5

The following supply voltages are generated by the 2x11,5 V:

- the supply voltage for VR 4 ( $+V_M = +10$  V) VR 3 ( $V_1 = +5$  V) and  $V_2 = +14$ V by a two-way rectifier (D6 / D8) and the center tap of the transformer
- the supply voltage for VR 5 ( $-V_M = -10$  V) by D7 / D9
- the supply voltage for VR 6 ( $-V_A = -15$  V) by a voltage doubler D13, D14, D15 and C20

The supply voltages  $V_{+50}$  and  $V_{-50}$  for the output stage of the amplifier are generated by the 2x35 V through a bridge circuit of the double diodes D44/D55 and center tap of the transformer.

Fusing is accomplished for the voltages

$V_{+50}; V_{-50}$	through Si 1/ Si 2 with T5A
$+V; -V; -V_A; V_1; V_2$	through Si 3/ Si 4 with T3, 15A
$V_3; V_4; +V_A$	through Si 5 with T2,5 A

The LED's indicate the following supply voltages when lightning at the same intensity:

- LED 1 = +28 V
- LED 2 = +14 V
- LED 3 = -14 V
- LED 4 = -22 V
- LED 5 = +/- 50 V

LED 7 lights up with picked-up REL 1 (2 sec. time-variant) after power on.

The amplifier then operates in normal mode.

#### 3.11.2. Stereo amplifier

The stereo amplifier is built up with a Siemens audio processor TDA 4390. An integrated AVC (automatic volume compensation) will be effective when input levels of CD, tape, or microphone differ considerably.

It contains a mode switch for mono, stereo, s-stereo, as well as a POWER-MOSFET output stage for 2x200 Watt music power at loudspeakers with a 4 Ω impedance.

## 1 Signal path

The audio signal of the CD changer is connected via IC 3A resp. IC 3B to PIN 1 resp. PIN 28 of the input selection circuit of the audio processor. The inputs IC1 3/26 are connected via MIC, the inputs IC1 2/27 via TB. Via the AVC with switch S1 (basis extension) the signal reaches the sound adjustment network and the volume stage of the audio processor monitored by the I2C-bus.

The signal outputs PIN 13/16 of IC1 are situated near the input of the operation amplifier IC4 of the output stage. With LB6 being open T29 leads to a phase angle rotation if the output of the output stage shall be operating in bridge circuit mode, resp. mono mode for special connection (left channel inverted). The driver transformers T14/ T15 resp. T17 /T18 are connected to the complementary POWER-MOSFETs T20 /T22 resp. T21/T23.

## 2 Protective functions for amplifier and loudspeaker

1. Rise-delay time of loudspeakers, therefore avoiding of noises when switching on and off.
2. Direct current-control of the amplifier outputs when output stage is defective. If a disturbance occurs the loudspeakers will be switched off within a short time. LED 7 signalizes the disturbance.
3. Overloading through undermatch. T27 /28 function as threshold value switches of the electronic fuses. T8 and T9 care for a reduction of volume through the CB Control unit. Volume is reduced until the electronic fuse does not react anymore.
4. The thermal switches on the heat sinks switch off the power of the output stages when the heat sink temperature reaches approx. 90° (cooling malfunction). The switch-on point is at about 60°C (switch-on hysteresis).

The moving load at the loudspeaker output shall not fall below 3,2 Ω. When undermatch resp. short circuit occur the limitation by an electronic fuse sets in. As consequence the volume is reduced. After clearing the undermatch the amplifier is operative again and volume can be reset.

## 3 Adjustment of volume:

The adjustment of volume for normal acoustic is controlled by P053 in the service program for each right and left channel separately.

With keys "1" resp. "7" more volume and with keys "3" resp. "9" less volume is adjusted.

With keys "4" resp. "6" volume is adjusted synchronically for both channels.

Volume also can be adjusted with the remote control (option) or with the keys on the rear side of the phonograph.

## 4 Adjustment of sound:

The adjustment of bass and treble is controlled by P054 in the service program.

Both channels are adjusted synchronically.

Keys "1" resp. "7" change bass, key "4" mean value for bass.

Keys "3" resp. "9" change treble, key "6" mean value for treble.

The necessary adjustment mainly depends on the acoustics of the environment of the phonograph.

A maximum treble response is only necessary in strongly damped rooms.

**5 Stereo / mono switch**

The mode switch S1 is located on the CB CENTRAL UNIT. With it you can settle different operational modes for acoustic irradiation of the environment.

Table 10: Stereo / mono switch of Central Unit

<b>Switch S1:</b>	
<b>Position</b>	<b>Operational Mode</b>
MONO	e.g. for separated volume control in different rooms
STEREO	normal mode
S-STEREO	base wide function

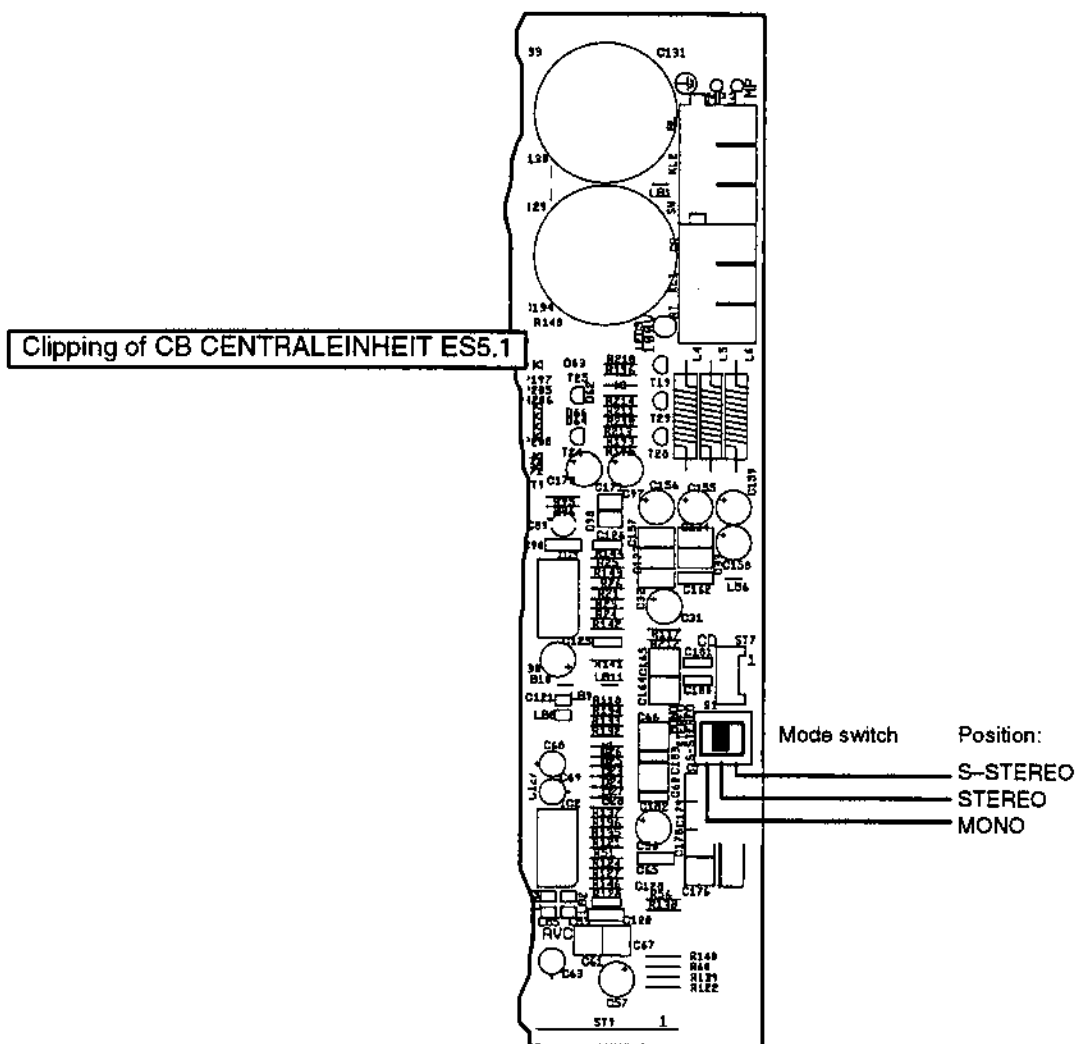

Figure 40: Mode switch S1 on the CB CENTRAL UNIT ES5.1

3.11.3. Repair Assistance CB CENTRAL UNIT ES5.1

1 Malfunction: No sound, no output power

It is assumed that:

- LED 1-5 and LED 7 light with the same intensity if the power supply is o.k.
- a CD is being played on the CD player
- normal volume has been set in program step P 053 to "31" (maximum)

LED 7 is dark: REL 1 is down, loudspeakers are off. The constant voltage level of >1V is at the loudspeaker output. Verify at L1 resp. against GND on which channel the constant voltage is located. Replace MOSFET-transistors T20 /T22 resp. T21 /T23.

LED 5 is dark: SI 1; SI 2 defective, ±50V supply or MOSFET-transistors defective.

2 Setting of static current

After exchange of POWER-MOSFET-transistors the static current has to be controlled. The value of the static current depends on the value of the operating voltage (U/2). Measurement takes place with source resistors R163 and R164 respectively R190 and R191 in cold state at volume level = "0".

If necessary correct the value of the measured direct voltage using trimmer R175 respectively R200 according to the following table.

Table 11: Measured values for setting the static current

Operating voltage (U/2)	Measured value	Tolerance
44 V=	0,2 mV	+/-0,05 mV
46 V=	0,5 mV	+/-0,1 mV
48 V=	1,0 mV	+/-0,2 mV
50 V=	2,0 mV	+/-0,4 mV

Note: Do not perform the adjustment of the static current if the operating voltage is less than 44V=.

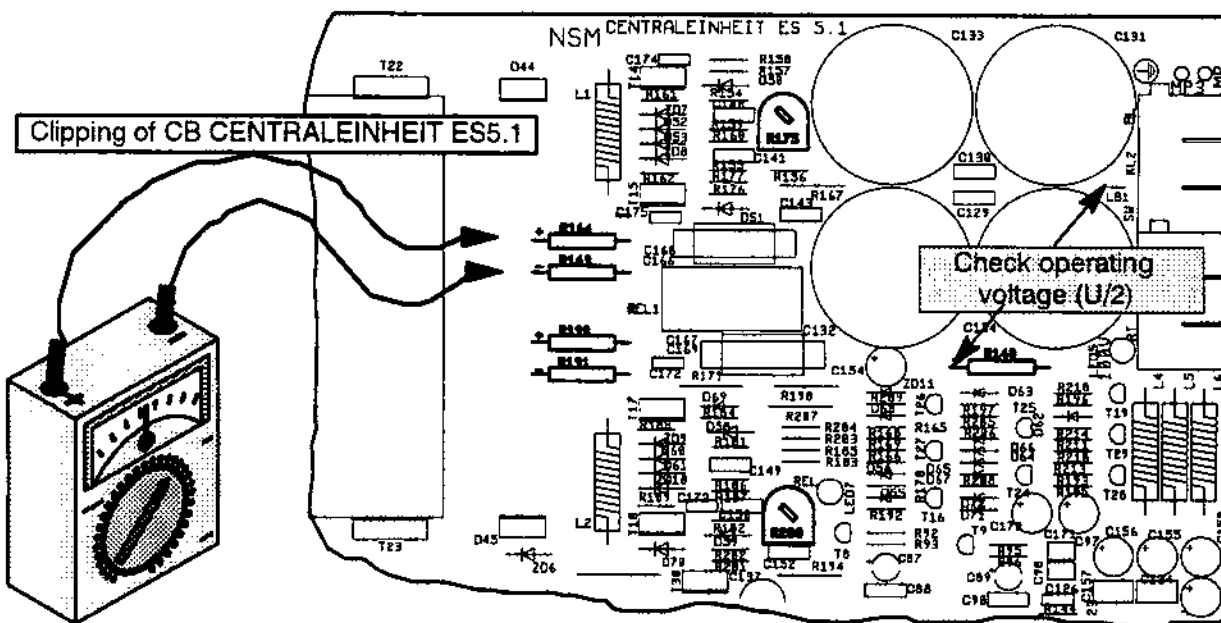

Figure 41: Setting of static current

### 3 Audio signal tracing

The audio signal arriving at plug ST 7 is to be traced according to table. Probably the error cause may be detected on the signal path preceding the point of interruption of the signal.

Table 12: Audio signal tracing

NF-Signal point	Error cause when signal fails
IC1, Pin 1 resp. Pin 28	IC 3- C48/ C52
IC 1, Pin 5 resp. PIN 24	IC 1
IC 1, Pin 6 resp. PIN 23	IC 2 (AVC)
IC 1, Pin 13 resp. PIN 16	IC 1
IC 4, Pin 1 resp. PIN 7	IC 4, T12, T13
T14 /T15 / T17 / T18 (collector)	the respective transistor
L1 / L2	T20 /T22 or T21 / T23

For the location of the signal points refer to the following figure.

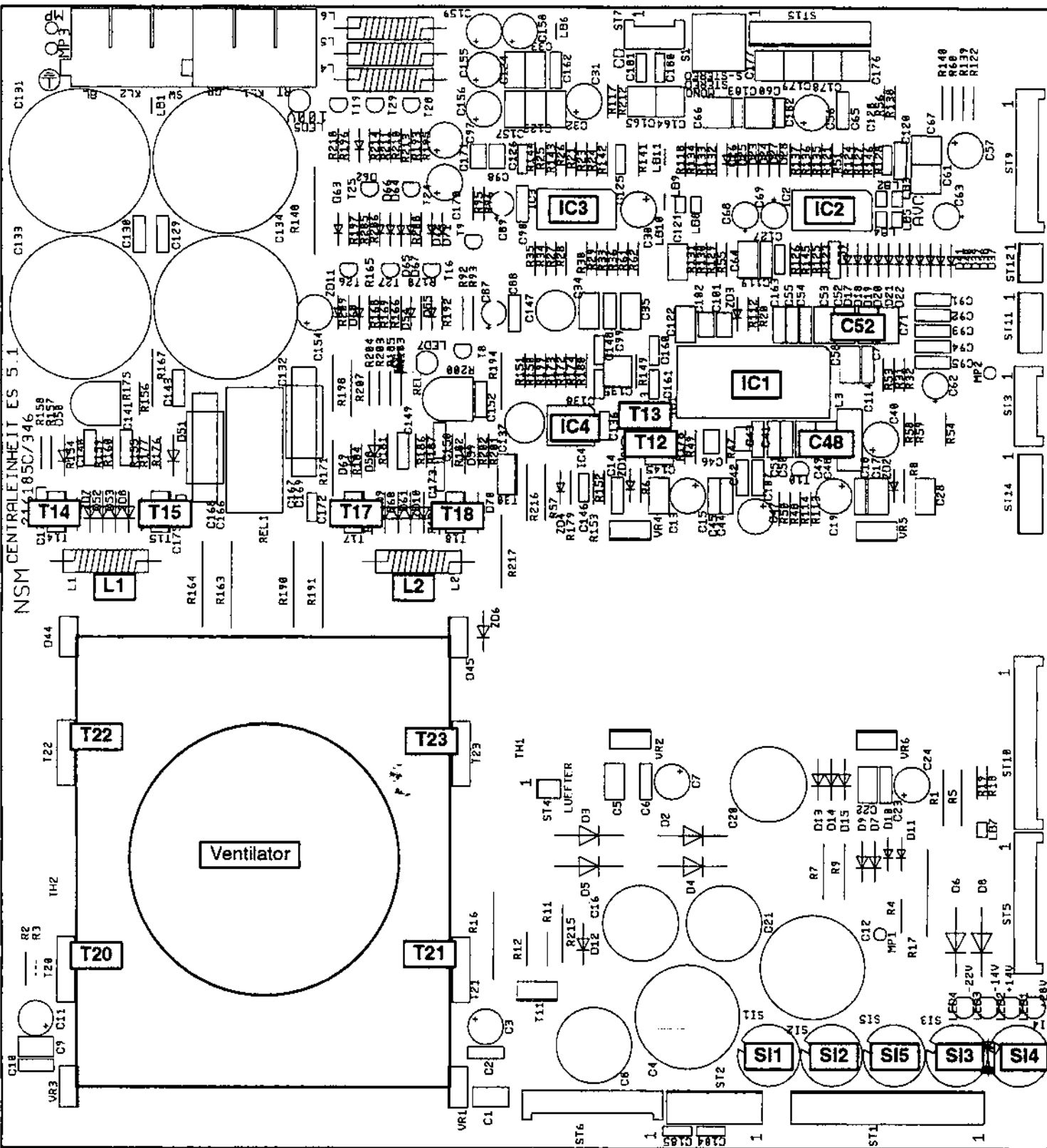
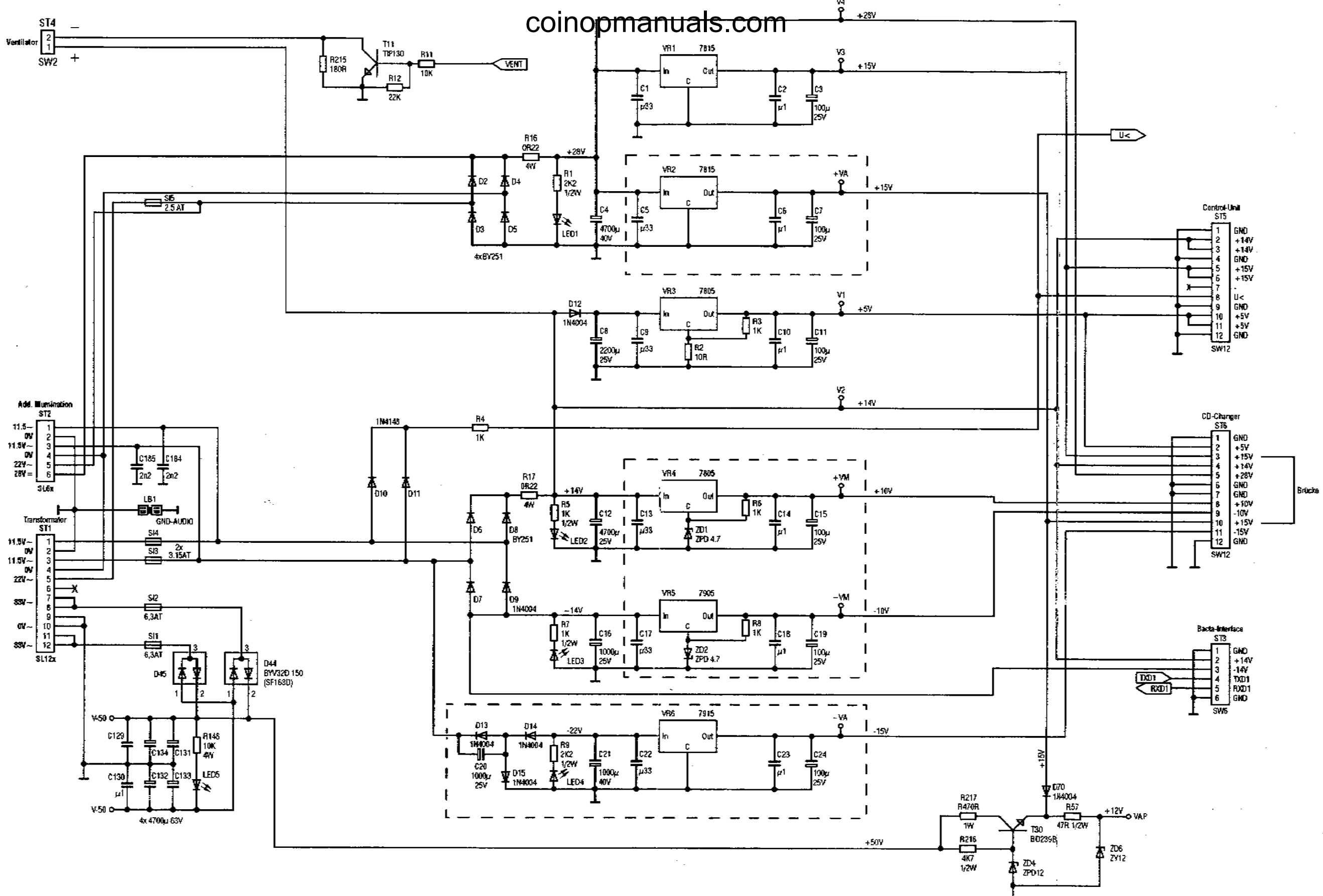

Figure 42: NF-signal points in the CB CENTRAL UNIT ES5.1





[ ] UMRAHMT BAUTEILE SIND  
 [ ] NICHT EINGEBAUT!  
 [ ] FRAMED PARTS ARE NOT INSTALLED!

ÄNDERUNGEN IM SINNE DES TECHN. FORTSCHRITTES VORBEHALTEN,  
 JEDOCH KEINE NACHRUSTPFLICHT!  
 SUBJECT TO TECHNICAL MODIFICATION WITHOUT OBLIGATION  
 TO MODIFY EQUIPMENT ALREADY DELIVERED!

**NSM** MUSIKAUTOMATEN PHONOGRAPHS **ES V-CD** TECHNOLOGY  
 Schaltbild / Wiring Diagram (Ser.Nr. 178 473)  
**CENTRALEINHEIT ES 5.1**  
**POWER - SUPPLY**

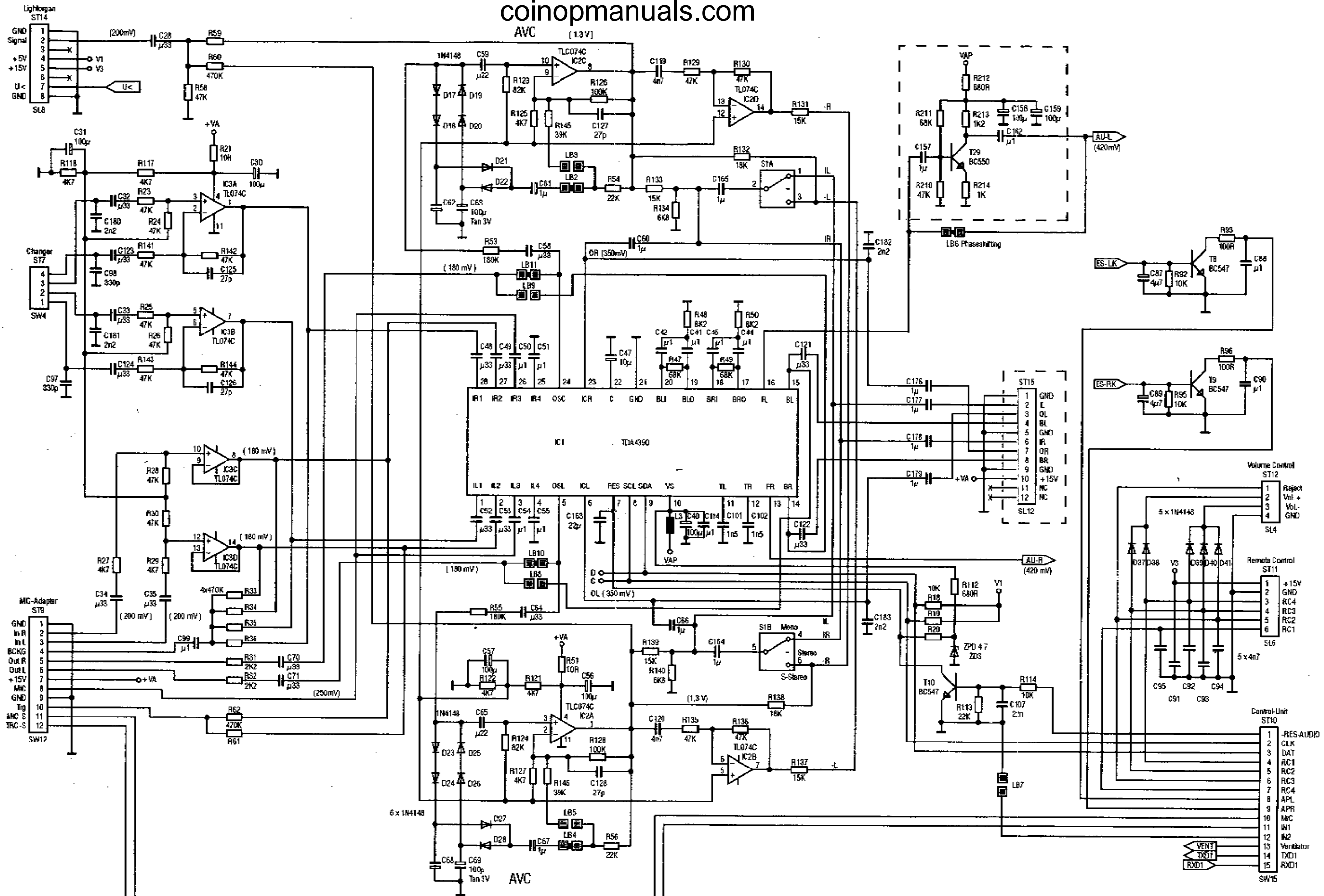

(Audio - Signal ohne AVC bei f = 1 KHz)

- UMRAHMT BAUTEILE SIND NICHT EINGEBAUT!
- FRAMED PARTS ARE NOT INSTALLED!

ÄNDERUNGEN IM SINNE DES TECHN. FORTSCHRITTES VORBEHALTEN, JEDOCH KEINE NACHRÜSTPFLICHT!

SUBJECT TO TECHNICAL MODIFICATION WITHOUT OBLIGATION TO MODIFY EQUIPMENT ALREADY DELIVERED!

**NSM** MUSIKAUTOMATEN PHONOGRAPHS **ES V-CD** TECHNOLOGY

Schaltbild / Wiring Diagram ( Part No. 178 473 )

# CENTRALEINHEIT ES 5.1 AUDIO

Dr	05.02.97	Gez	Manz	Sach	Yes.	Gez	Yes.
----	----------	-----	------	------	------	-----	------

{ Audio - Signal ohne AVC bei f=1 KHz }

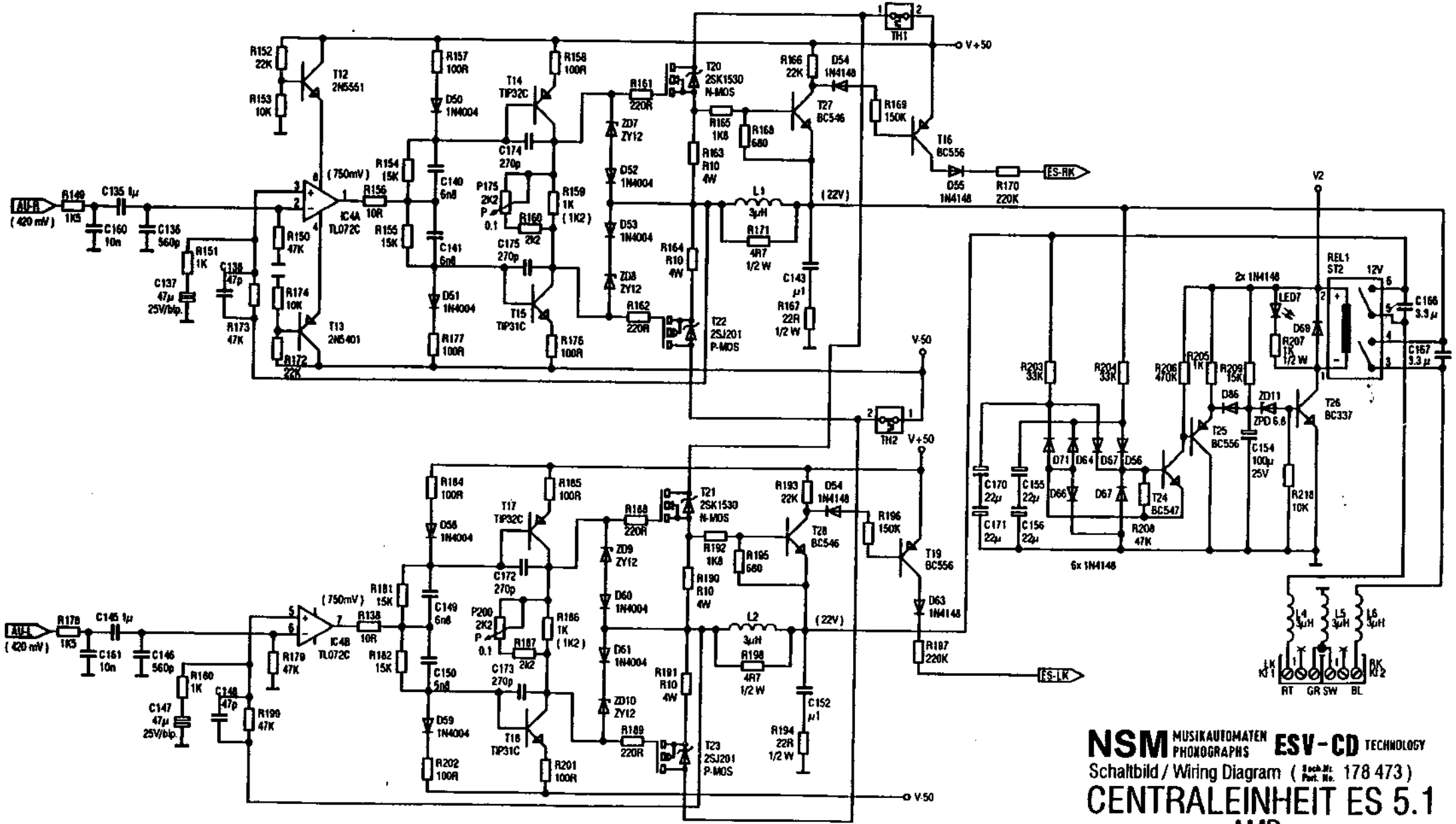

**NSM** MUSIKAUTOMATEN PHONOGRAPHS **ESV-CD** TECHNOLOGY  
 Schaltbild / Wiring Diagram (Sch.Nr. 178 473)  
**CENTRALEINHEIT ES 5.1**  
 AMP

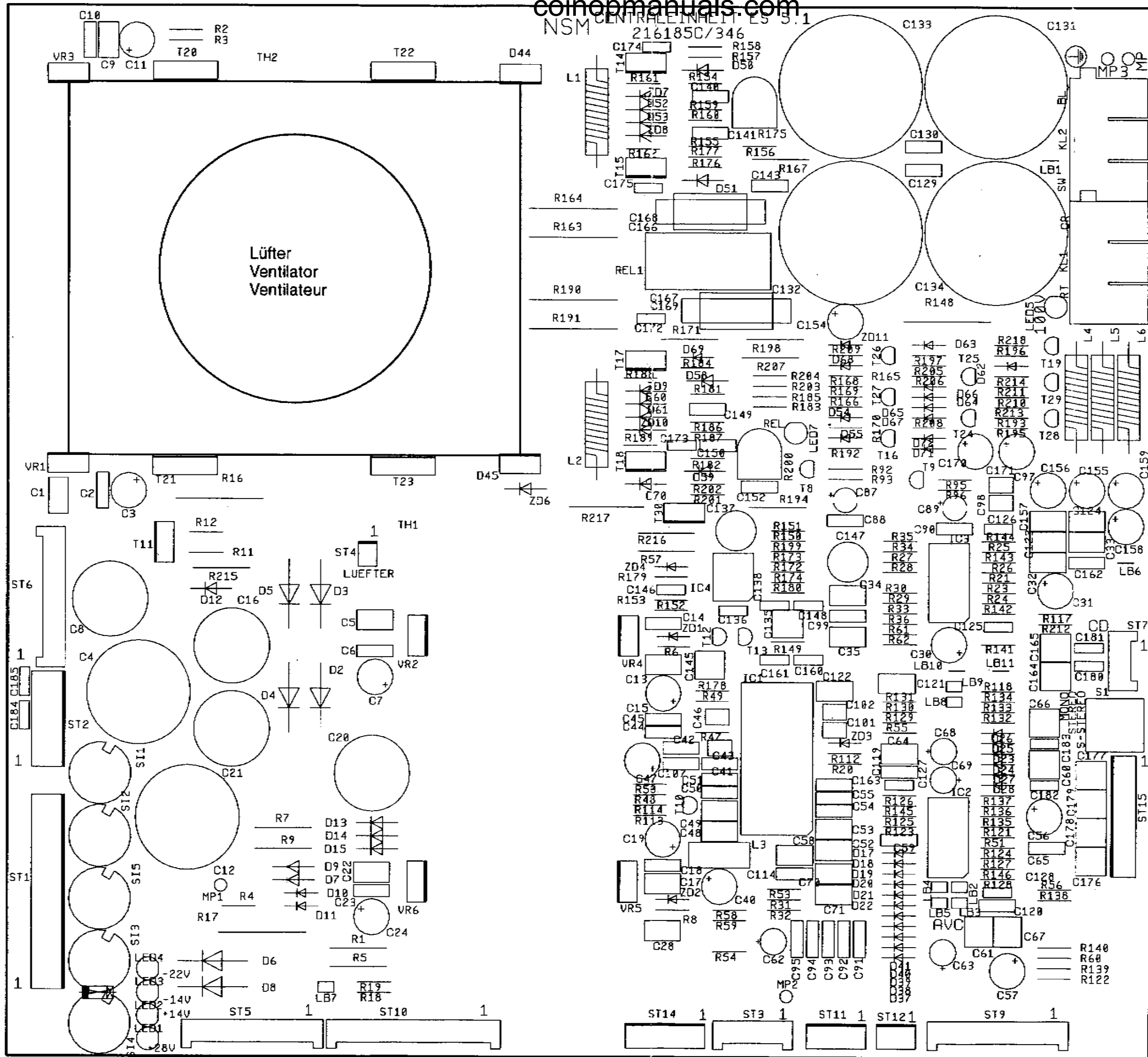

Bestückungsaufdruck  
 Component side  
 Équipement de CI  
 Centraleinheit ES5.1 Rev.C  
 30.05.1998

Pos.	Part-No.	Description	Data	Quantity
	<b>178 972*</b>	<b>Central Unit ES5.1 / 50 Hz MBC III, complete</b>		<b>1</b>
	235 137	Cap	50 Hz	5
Si5	225 538	G-fuse	T2,5A	1
Si3, Si4	225 029	G-fuse	T3,15A	2
Si1, Si2	225 374	G-fuse	T6,3A	2
	<b>178 973</b>	<b>Central Unit ES5.1 / 60 Hz MBC III, complete</b>		<b>1</b>
	235 138	Cap	60 Hz	5
Si5	225 222	G-fuse	2.5A / 250V	1
Si3, Si4	225 225	G-fuse	3,2A / 250V	2
Si1, Si2	225 218	G-fuse	6,25A / 250V	2
		<b>Central Unit ES5.1-MBC III</b>		<b>1</b>
Si1-Si5	235 136	G-fuse		5
L3	220 488	HF-Ballast	*Ferrit*	1
L1,L2, L4-6	220 387	Ballast	3 $\mu$ H, 19M $\Omega$	5
REL1	223 453	HD-Relay	ST2 12V	1
S1	222 550	Slide switch		1
TH1,TH2	222 485	Temperature guide		2
	177 440	Ventilator, complete		1
ST4	225 441	Plug connector	2 poles	1
ST12	225 418	Plug connector	4 poles	1
ST2	235 042	Plug connector	6 poles	1
ST11	225 443	Plug connector	6 poles	1
ST14	225 444	Plug connector	8 poles	1
ST1	235 045	Plug connector	12 poles	1
ST7	225 651	Pin plug	4 poles	1
ST3	225 711	Pin plug	6 poles	1
ST5,6,9	225 714	Pin plug	12 poles	3
ST10	225 656	Pin plug	15 poles	1
KL1,KL2	225 422	Clamping bar	3 poles	2
VR1	112 976	IC-voltage regulator	15 V/1,5 A	1
VR3	112 974	IC-voltage regulator	5 V/1 A	1
IC1	222 447	IC-socket	28polig	1
IC1	231 540	IC-linear	TDA 4390	1
IC2,IC3	231 355	IC-linear	L 074CN	2
IC4	231 692	IC-linear	TL 072C	1
D....	221 114	Si-diode	1N4148	31
D....	221 115	Si-diode	1N4004	12
D2-D6, D8	221 463	Si-diode	BY 251	6
LED1-3,5,7	231 475	LED	LTL-4223021	5
ZD3	231 079	Zener-diode	ZPD 4,7	1
ZD11	231 410	Zener-diode	ZPD 6,8	1
ZD4	221 512	Zener-diode	ZPD12	1
ZD6-10	221 406	Zener-diode	ZY12	5
D44,45	177 703	Double diode	SF163D	2

\* Exchange unit

Pos .	Part-No.	Description	Data	Quantity	
Continuation: Central Unit ES5.1-MBC III					
T30	221 883	Si-Transistor	BD 239B	1	
T26	221 332	Si-Transistor	NPN BC 337-16	1	
T27,28	221 485	Si-Transistor	NPN BC 546B	2	
T8-10,24	221 757	Si-Transistor	NPN BC 547B	4	
T16,19,25	221 459	Si-Transistor	PNP BC 556B	3	
T11	231 150	Si-Transistor	NPN TIP130	1	
T13	231 693	Si-Transistor	PNP 2N5401	1	
T12	231 694	Si-Transistor	NPN 2N 5551	1	
T22,23	231 695	MOS-Transistor	2SJ 201	2	
T20,21	231 696	MOS-Transistor	2SK1530	2	
T15,18	231 697	Darlington-Transistor	NPN TIP31C	2	
T14,17	231 698	Darlington-Transistor	NPN TIP32C	2	
R93,96,157,158,176, 177,184,185,201, R202, R161,162, 188,189	231 815	Met.-Resistance	100 Ω	0,34W	10
R112, R168,195 R165,192	231 816	Met.-Resistance	220 Ω	0,34W	4
R2,21,51, 156,183 R3,4,151,180 R205 R159,186 R149,178	231 817	Met.-Resistance	680Ω	0,34W	3
R31,32,160 R187	231 814	Met.-Resistance	1,8KΩ	0,34W	2
R27,29,117, R118,121, R122,125,127	221 611	Resistance	10 Ω	0,34W	5
R134,140 R48,50	221 029	Resistance	1KΩ	0,34W	5
R11,18-20,92,95, R114 153,174,218	221 627	Resistance	1,2KΩ	0,34W	2
R131,133,137,139, R154,155,181 R182,209 R192,138 R12,54,56,113,152, R166,172,193, R203,204 R145,146	221 030	Resistance	1,5KΩ	0,34W	2
R23-26,28,30, 58,129,130,135, 136,141-144,150,173 179,199,208	221 031	Resistance	2,2KΩ	0,34W	4
R122,125,127	221 034	Resistance	4,7KΩ	0,34W	8
R134,140 R48,50	221 607	Resistance	6,8KΩ	0,34W	2
R11,18-20,92,95, R114 153,174,218	221 172	Resistance	8,2KΩ	0,34W	2
R11,18-20,92,95, R114 153,174,218	221 035	Resistance	10KΩ	0,34W	10
R131,133,137,139, R154,155,181 R182,209 R192,138 R12,54,56,113,152, R166,172,193, R203,204 R145,146	221 036	Resistance	15KΩ	0,34W	9
R23-26,28,30, 58,129,130,135, 136,141-144,150,173 179,199,208	221 501	Resistance	18KΩ	0,34W	2
R12,54,56,113,152, R166,172,193, R203,204 R145,146	221 604	Resistance	22KΩ	0,34W	8
R23-26,28,30, 58,129,130,135, 136,141-144,150,173 179,199,208	221 037	Resistance	33KΩ	0,34W	2
R12,54,56,113,152, R166,172,193, R203,204 R145,146	221 623	Resistance	39KΩ	0,34W	2
R23-26,28,30, 58,129,130,135, 136,141-144,150,173 179,199,208	221 038	Resistance	47KΩ	0,34W	20

Pos.	Part-No.	Description	Data		Quantity
Continuation: Central Unit ES5.1-MBC III					
R47,49,	221 629	Resistance	68K $\Omega$	0,34W	2
R123,124	221 044	Resistance	82K $\Omega$	0,34W	2
R126,128	221 048	Resistance	100K $\Omega$	0,34W	2
R169,196	221 045	Resistance	150K $\Omega$	0,34W	2
R53,55	221 605	Resistance	180K $\Omega$	0,34W	2
R170,197	221 609	Resistance	220K $\Omega$	0,34W	2
R33-36,59-62					
R206	221 049	Resistance	470K $\Omega$	0,34W	9
R215	231 144	Resistance	180 $\Omega$	0,5W	1
R171,198	231 700	Resistance	4,7 $\Omega$	0,5W	2
R167,194	221 865	Resistance	22 $\Omega$	0,5W	2
R57	221 161	Resistance	47 $\Omega$	0,5W	1
R5,7,207	221 183	Resistance	1K $\Omega$	0,5W	3
R1	221 184	Resistance	2,2K $\Omega$	0,5W	1
R216	221 397	Resistance	4,7K $\Omega$	0,5W	1
R163,164,					
R190,191	231 204	Wire resistor	0,1 $\Omega$	4W	4
R16,17	231 176	Wire resistor	0,22 $\Omega$	4W	2
R217	221 276	Wire resistor	470 $\Omega$	1W	1
R148	231 699	Wire resistor	9,1K $\Omega$	4W	1
R175,200	221 305	Trimmer potentiometer	2,2K $\Omega$ Lin.	0,1W	2
C125-128	220 266	Ceramic capacitor	27pF	400V	4
C138,148	220 181	Ceramic capacitor	47pF	400V	2
C97,98	220 274	Ceramic capacitor	330pF	400V	2
C136,146	220 241	Ceramic capacitor	560pF	400V	2
C172-175	220 185	Ceramic capacitor	270pF	400V	4
C180-185	220 231	Ceramic capacitor	2200pF	400V	6
C91-95,119,120	220 341	Ceramic capacitor	4700pF	100V	7
C101,102	220 496	Ceramic capacitor	1,5nF		2
C140,141,149,150	220 534	Ceramic capacitor	6,8nF	63V	4
C160,161	220 425	MKT-capacitor	0,01 $\mu$ F	100V	2
C107,163	220 335	MKT-capacitor	0,022 $\mu$ F	63V	2
C2,10,41,42,44,45,50,, 51,54,55,88,90,99,114,					
C129,130,143,152	220 334	MKT-capacitor	0,1 $\mu$ F	63V	18
C59,65	220 333	MKT-capacitor	0,22 $\mu$ F	63V	2
C1,9,28,32-35,48,49,, C52,53,58,64,70,71,					
C121-124	220 332	MKT-capacitor	0,33 $\mu$ F	63V	19
C60,61,66,67,135,145,					
C164,165,176-179	220 535	MKT-capacitor	1 $\mu$ F	63V	12
C166,167	220 460	MKT-capacitor	3,3 $\mu$ F	63V	2
C62,63,68,69	220 243	Tantal-capacitor	100 $\mu$ F	3V	4
C87,89	220 159	Electrolytic-capacitor	4,7 $\mu$ F	63V	2
C47	220 162	Electrolytic-capacitor	10 $\mu$ F	63V	1
C155,156,170,171	220 317	Electrolytic-capacitor	22 $\mu$ F	63V	4
C11	220 160	Electrolytic-capacitor	100 $\mu$ F	10V	1
C3,30,31,					
C40,56,57,154	220 250	Electrolytic-capacitor	100 $\mu$ F	25V	7
C16	220 281	Electrolytic-capacitor	1000 $\mu$ F	25V	1
C8	220 283	Electrolytic-capacitor	2200 $\mu$ F	25V	1
C12	220 286	Electrolytic-capacitor	4700 $\mu$ F	25V	1
C4	220 287	Electrolytic-capacitor	4700 $\mu$ F	40V	1
C131-134	220 436	Electrolytic-capacitor	4700 $\mu$ F	63V	4
C137,147	220 553	Electrolytic-capacitor bipolar	4,7 $\mu$ F	25V	2

### 3.12. Functional description of the CB CONTROL UNIT ES V

The microprocessor (IC 1) on the CONTROL UNIT is the central control chip of the phonograph. It drives, controls, and monitors all functions of the appliance, e.g. display, keyboard, coin mechanism, title display, sound, and volume as well as the drive of the CD changer.

The control unit is equipped with a battery-buffered RAM IC 5 (battery-RAM) including a real time clock. The selected titles, credits, and actual adjustments of sound and volume are stored in this RAM.

With the service programs several adjustments can be programmed and stored. E.g. specific parameters, prices for titles to be played, monetary settings, free credits, background music, autoplay, lock-out titles, and so on.

The integrated real time clock allows to activate several functions automatically depending on the actual date and time.

Within the RAM of the control unit voluminous statistic counters are stored. They can be evaluated with help of the service programs. They also can be printed out on the DATA PRINT. Statistical data are e.g.

- popularity of the CDs
- hitparade
- cash box
- counters of coin mechanism
- selected or played titles or albums
- autoplays
- free credits
- background titles
- advertisement titles

Additionally the last 20 error reports are stored in an error stack with date and time of occurrence in case of a malfunction of the phonograph. This stack can be evaluated and printed out for diagnostics.

In case that the CB CONTROL UNIT or the memory chips located on it have to be exchanged all parameters mentioned above have to be programmed anew.

Therefore it is advisable to note down the programming of the phonograph.

The new CB CONTROL UNIT resp. the new memory chip simply can be reprogrammed with these parameters.

**Environmentally note:** The CB CONTROL UNIT is equipped with a battery-buffered SRAM (IC5). Please take care to put this chip as toxic waste to the special waste dump for disposal.



3.12.1. Test routines for the CB CONTROL UNIT

The input test checks all input ports and shows the results in a matrix on display 3. The test can be stopped by pressing "C".

0: Start input test (display 2 briefly shows F7)

Enter: P 156 H 0

i.e. key switch operated:



The 4 digits of displays are used as follows:

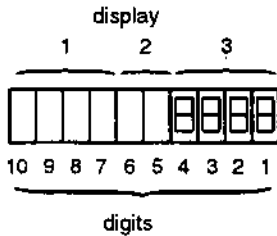

- digit 1: State of operation  
0 = locked; not able to call background music  
1 = free
- digit 2: Bit number of input port (see table 13 "Attaching...", )
- digit 3: Port number from which input occurs (see table 14: "Port-numbers of input ports").
- digit 4: Not used.

Table 13: Attaching of bit numbers to input ports

Bit number	corresponds to wiring diagram "Control Unit"	
0	signal line	A
1		B
2		C
3		D
4		E
5		F
6		G
7		H

Table 14: Port-numbers of input ports

Port number	name of input port
0	Control Unit (IC15)
1	Control Unit (IC16)
2	Control Unit (IC17)
3	Key pad
4	Title display (IC1)
5	Not used
6	Pickup driver (IC3)

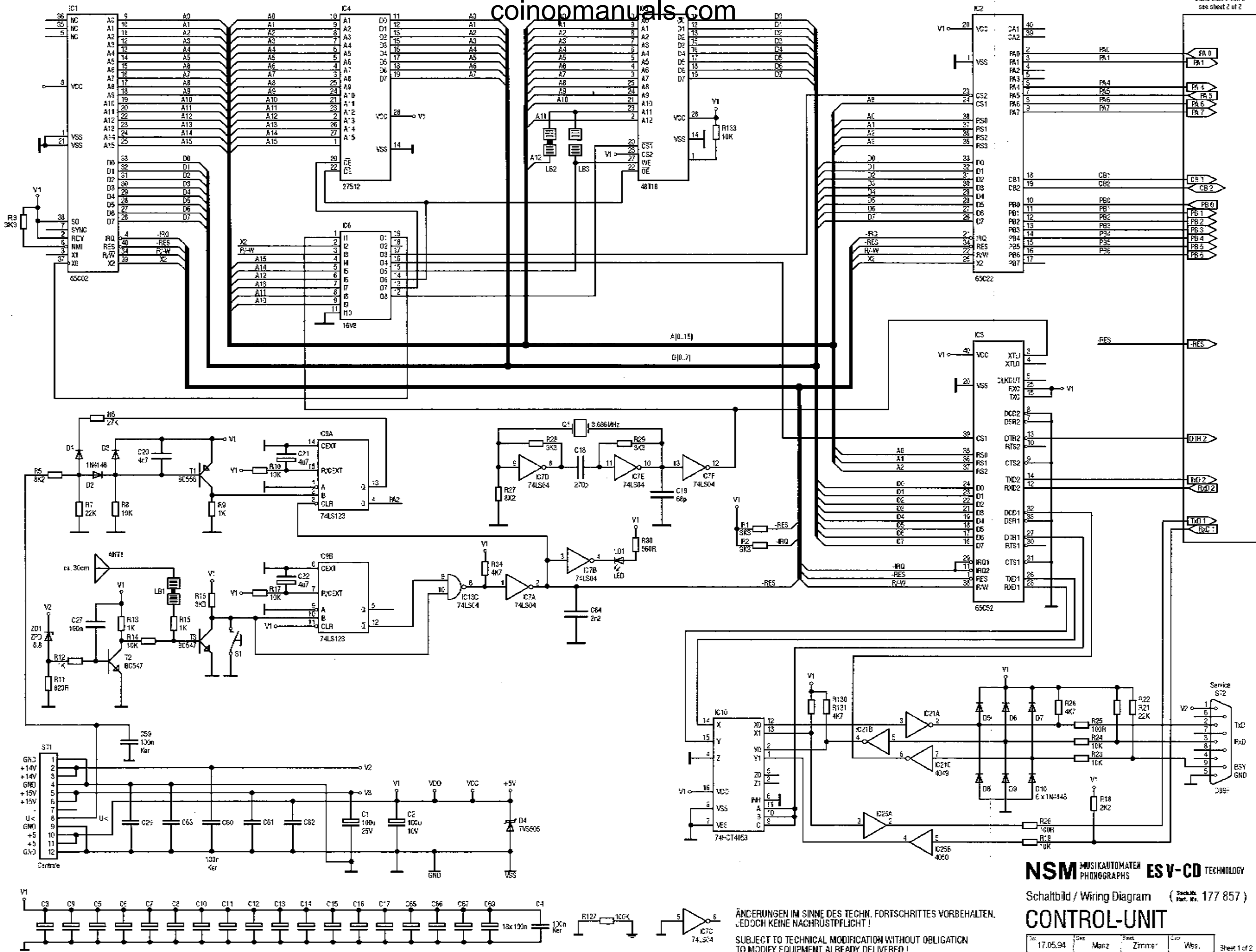

ÄNDERUNGEN IM SINNE DES TECHN. FORTSCHRITTES VORBEHALTEN.  
JEDOCH KEINE NACHRÜSTPFLICHT!  
SUBJECT TO TECHNICAL MODIFICATION WITHOUT OBLIGATION  
TO MODIFY EQUIPMENT ALREADY DELIVERED!

**NSM MUSIKAUTOMATEN PHONOGRAPHS** **ESV-CD TECHNOLOGY**  
 Schaltbild / Wiring Diagram (Tech. No. 177 857)  
**CONTROL-UNIT**  
 No. 17.05.94 Date März Sheet Zimmer Gyor Wes. Sheet 1 of 2  
 Úszár / tétel / Revised : 06.03.1998

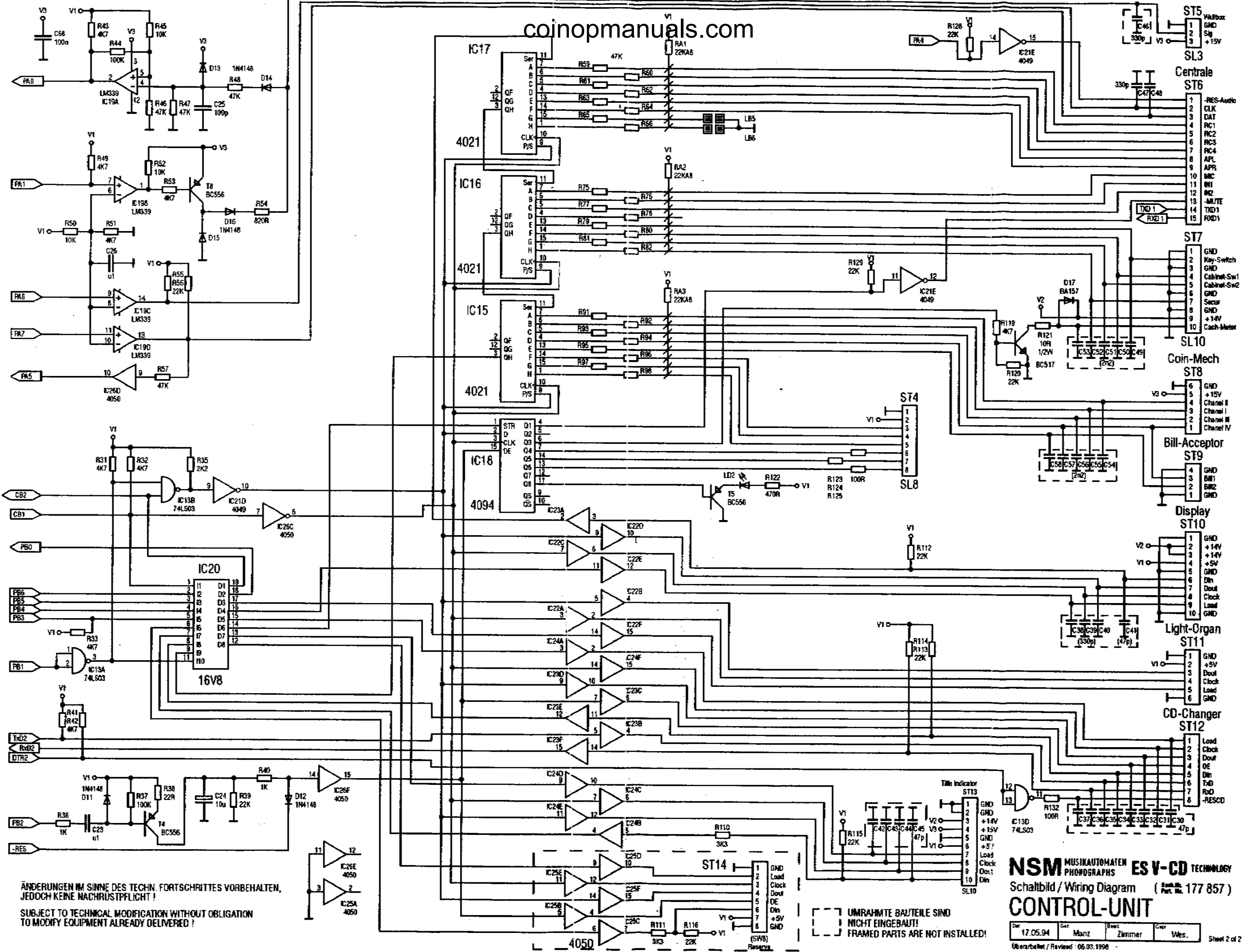

ÄNDERUNGEN IM SINNE DES TECHN. FORTSCHRITTES VORBEHALTEN, JEDOCH KEINE NACHRUFPLICHT!  
 SUBJECT TO TECHNICAL MODIFICATION WITHOUT OBLIGATION TO MODIFY EQUIPMENT ALREADY DELIVERED!

UMRAHMTTE BAUTEILE SIND NICHT EINGEBAUT!  
 FRAMED PARTS ARE NOT INSTALLED!

**NSM MUSIKAUTOMATEN PHONOGRAPHS ES V-CD TECHNOLOGY**  
 Schaltbild / Wiring Diagram (Part No. 177 857)  
**CONTROL-UNIT**

Rev.	17.05.94	Gez.	Manz	Gez.	Zimmer	Gez.	Wes.
Überarbeitet / Revised: 06.03.1998							

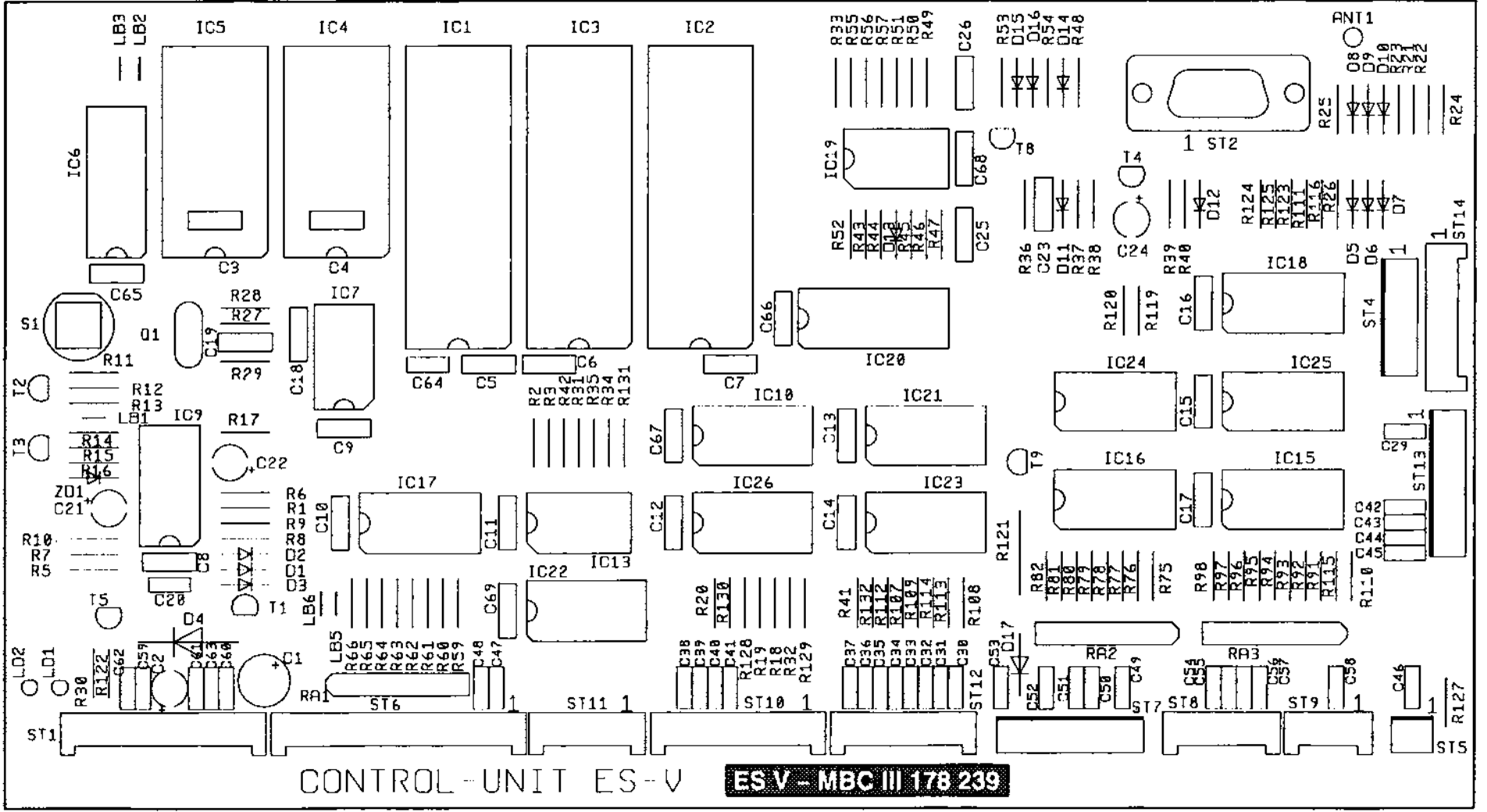

Pos.	Part-No.	Description	Data	Quantity
	<b>178 239 *</b>	<b>CB-CONTROL UNIT ES V-MBC III, complete</b>		<b>1</b>
	250 311	Profile	251 mm long	1
ST 9	225 651	Pin plug	4 poles	1
ST 8	225 652	Pin plug	6 poles	1
ST 11	225 992	Pin plug red	6 poles	1
ST 12	225 653	Pin plug	8 poles	1
ST 10	225 654	Pin plug	10 poles	1
ST 1	225 655	Pin plug	12 poles	1
ST 6	225 656	Pin plug	15 poles	1
ST 5	225 439	Plug connector	3 poles	1
ST 7, 13	225 440	Plug connector	10 poles	2
ST 2	225 828	D-Sub-connector	9 poles	1
Q 1	231 621	Oszillator quartz	3,6864 MHz	1
IC 6	176 397	IC-PAL, programmed	DECO 1.0	1
IC 20	176 561	IC-PAL, programmed	MUX 1.0	1
	222 447	IC-Socket for IC4, IC5	28 poles	2
IC 4	178 238	IC-Memory, programmed		1
IC 5	231 497	IC-Memory	M48T18-150PC1	1
	222 448	IC-Socket for IC1, 2, 3	40 poles	3
IC 1	231 412	IC-Microprocessor	R65C02P2	1
IC 2	231 414	IC-Microprocessor	R65C22P2	1
IC 3	231 462	IC-Microprocessor	R65C52P3	1
IC 13	221 525	IC-Logic	74LS03	1
IC 7	221 652	IC-Logic	74LS04	1
IC 9	221 792	IC-Logic	74LS123	1
IC 10	231 339	IC-Logic	HCT4053	1
IC 15-17	221 763	IC-Logic	HEF4021B	3
IC 21	221 541	IC-Logic	F4049BC	1
IC 22-24, 26	221 810	IC-Logic	HEF4050BP	4
IC 18	221 771	IC-Logic	HEF4094B	1
IC 19	221 813	IC-Linear	LM 339 N	1
D 1-3, D 5-16	221 114	Si-Diode	1N4148	15
D 17	221 822	Si-Diode	1N4936RL	1
D 4	221 539	Transzorb-Diode	ICTE-5	1
ZD 1	231 601	Zener-Diode	ZPD 7,5	1
LD 1, 2	231 475	LED	LTL-4223021	2
T 2, 3	221 757	Si-Transistor	NPN BC 547B	2
T 9	221 492	Si-Transistor	NPN BC 517	1
T 1, 4, 5, 8	221 459	Si-Transistor	PNP BC 556B	4

\* Exchange unit

Pos.	Part-No.	Description	Data		Quantity
Continuation: LP-Control-Unit ESV-MBC III					
C3,4,9,29,60-63	220 481	Ceramic capacitor	0,1 $\mu$ F	63V	8
C19	220 242	Ceramic capacitor	68 pF	400V	1
C25	220 342	Ceramic capacitor	100 pF	400V	1
C18	220 185	Ceramic capacitor	270 pF	400V	1
C47,48	220 365	Ceramic capacitor	120 pF	400V	2
C37,64	220 231	Ceramic capacitor	2200 pF	63V	2
C20	220 435	KT-capacitor	4700 pF	63V	1
C5-8,10-17,23, C26,27,28 65-69	220 334	MKT-capacitor	0,1 $\mu$ F	63V	21
C21, 22	220 159	Electrolytic capacitor	4,7 $\mu$ F	63V	2
C24	220 162	Electrolytic capacitor	10 $\mu$ F	63V	1
C2	220 160	Electrolytic capacitor	100 $\mu$ F	10V	1
C1	220 250	Electrolytic capacitor	100 $\mu$ F	25V	1
R38	221 620	Resistance	22 $\Omega$	0,34W	1
R20,25, R123-125,132	221 600	Resistance	100 $\Omega$	0,34W	6
R122	221 099	Resistance	470 $\Omega$	0,34W	1
R30	221 621	Resistance	560 $\Omega$	0,34W	1
R11, 54	221 622	Resistance	820 $\Omega$	0,34W	2
R9, R12,13,15,36,40	221 029	Resistance	1 K $\Omega$	0,34W	6
R18,35	221 031	Resistance	2,2 K $\Omega$	0,34W	2
R1-3,16, R28,29,108-110	221 033	Resistance	3,3 K $\Omega$	0,34W	9
R26, 31-34,41-43, R49,51,53,119, R130,131	221 034	Resistance	4,7 K $\Omega$	0,34W	14
R5,27	221 172	Resistance	8,2 K $\Omega$	0,34W	2
R8,10,14,19,23, R24,45,46,50, R52,107,133	221 035	Resistance	10 K $\Omega$	0,34W	12
R7,21,22,39,55, R56,112-115, R120,128,129	221 604	Resistance	22 K $\Omega$	0,34 W	13
R6	221 601	Resistance	27 K $\Omega$	0,34 W	1
R47,48,57,59-66, 75-82,91-98,134	221 038	Resistance	47 K $\Omega$	0,34 W	28
R17,37,44,127	221 048	Resistance	100 K $\Omega$	0,34 W	4
R121	221 273	Resistance	10 $\Omega$	0,5 W	1
RA1-3	231 239	Resistor network	8x22 K $\Omega$		3

### 3.13. Functional description of display and keyboard

#### 3.13.1. Display

The multi-functional display with the integrated 12-button keyboard is the communication medium of the NSM phonograph. The juke box issues messages concerning instantaneous functions and malfunctions via the different displays and lamps. The keyboard waits for different inputs corresponding to input request.

Therefore the display serves as a display for a hitparade in normal operating mode (stand-by) respectively for the remaining credits and the CD played at that moment (normal operating mode).

In the service mode the program steps and the counts of a counter are indicated as well as programmed register contents and error messages.

The display is operated in multiplex-method. The shift registers IC 301 to IC 303 are the output-ports for the controlling means of the display. The segment information for each case 1 digit is provided with IC 302 and IC 303 via the driver IC 308 and IC 309. The transformers T 301 to 305, triggered by IC 307 via 301, connect the respectively multiplex-level for the duration of 4 ms. The resistors R 332 to R 345 limit the segment-voltage. The lamps L1 to L5 are statically triggered via IC 307, Pin 12, Pin 14 and IC 306, Pin 10, 11, 12. The resistors R 325 to 329 limit the current at make. The load signal for the output-shift register is controlled by the circuit IC 306, Pin 4 and 13; R 306; C 303; D 301. During the time of the load impuls the display is darkly touched (avoidance of cross-talk). C 303 is discharged via D 301 and IC 306, Pin 13. The OE of IC 301 to IC 303 will be LOW and therefore inactive. Is the load-signal off, OE will be inactive via R 305. Capacitor 302 avoids a short flash of the digits after connecting.

#### 3.13.2. Keyboard

The 12-button keyboard still has more functions.

In normal operating mode the keyboard serves to select titles and to reverse to hitparade (key H) respectively to correct input errors (key C). See also the following figure.

In service mode the different command numbers are put in via keyboard or the control commands for the lift alignments are given.

IC 304 is an input-port for the keyboard which is connected with plug ST 302. The circuit with the diodes D 302-307 and the transistors T 306, T 307 codes the keyboard-matrix to a 4-bit signal combination. The keyboard can only be changed entirely.

#### 3.13.3. Printed board of CB Display

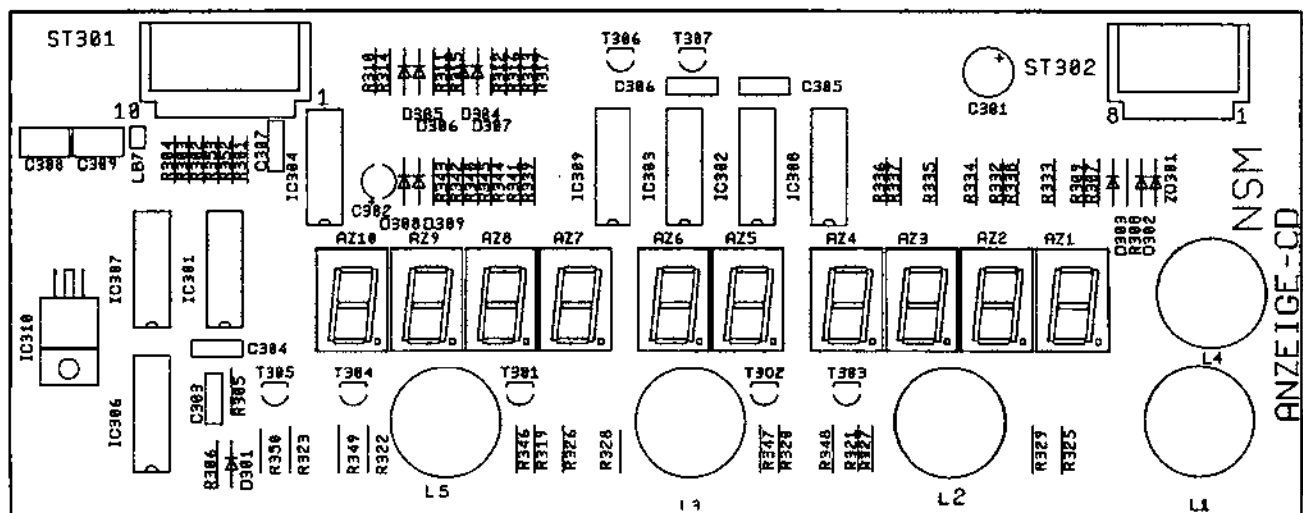

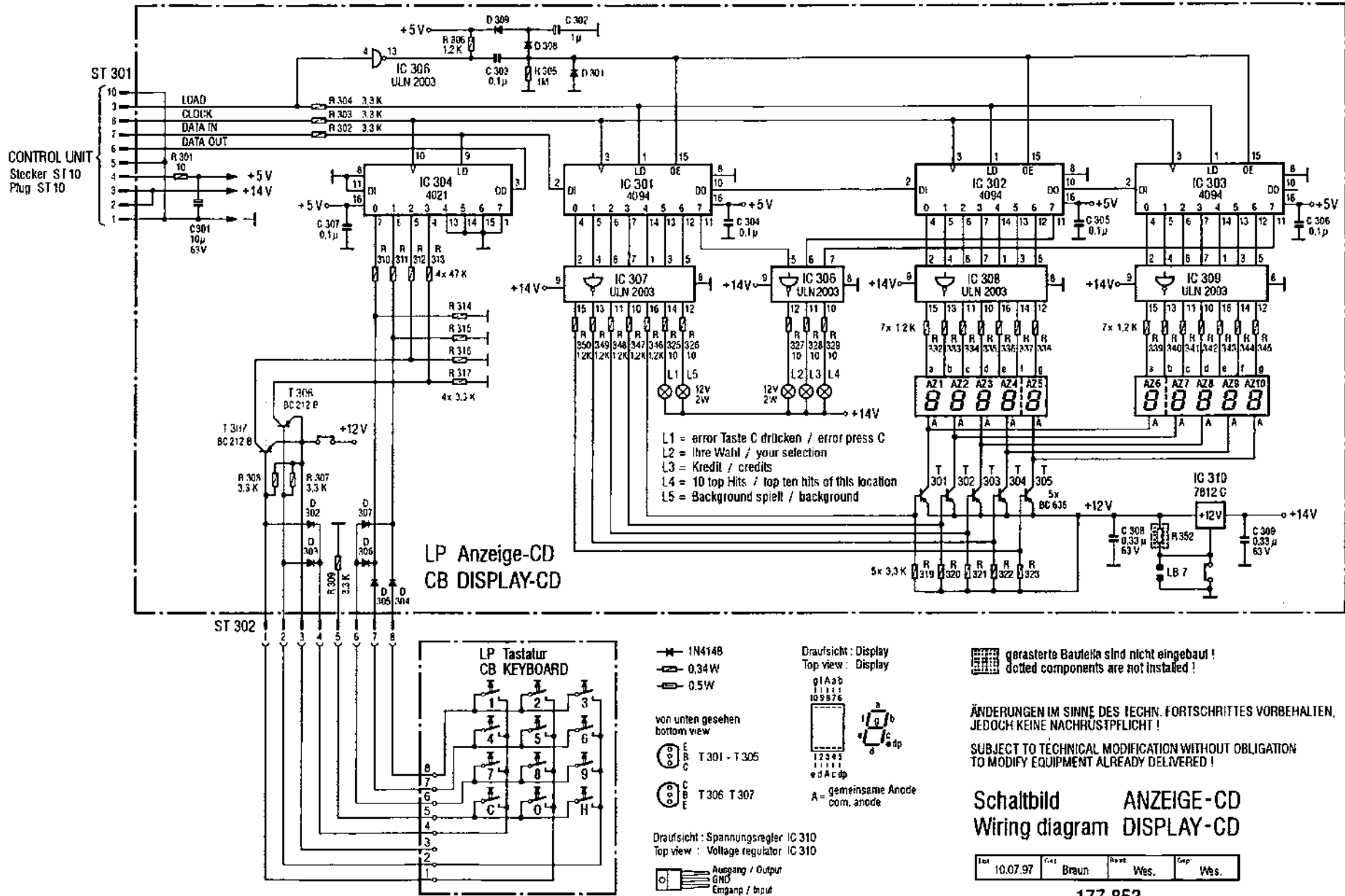



Pos.	Part-No.	Description	Data	Quantity
	<b>173 664</b>	<b>CB-DISPLAY-CD, complete</b>		<b>1</b>
ST 302	225 663	Pin plug	8 poles	1
ST 301	225 664	Pin plug	10 poles	1
AZ 1-10	231 416	Display	TD SL 5150	10
	176 413	Tubus		1
IC 310	221 573	IC-voltage regulator	12 V / 1 A	1
IC 301-303	221 771	IC-Logic	HEF 4094 B	3
IC 304	221 763	IC-Logic	HEF 4021 B	1
IC 306-309	221 497	IC-Linear	ULN 2003 A	4
D301-309	221 114	Si-Diode	1 N 4148	9
T 301-305	231 240	Si-Transistor	BC 636 F	5
T 306, 307	221 283	Si-Transistor	PNP BC 212 B	2
C 301	220 162	Electrolytic capacitor	10 $\mu$ F 63 V	1
C 302	220 249	Electrolytic capacitor	1 $\mu$ F 63 V	1
C 303-307	220 334	MKT-capacitor	0,1 $\mu$ F 63 V	5
C 308, 309	220 332	MKT-capacitor	0,33 $\mu$ F 63 V	2
R 301	221 611	Resistance	10 $\Omega$ 0,34 W	1
R 306, 332-350	221 627	Resistance	1,2 K $\Omega$ 0,34 W	20
R 302-304,307-309,314-317,319-323,354	221 033	Resistance	3,3 K $\Omega$ 0,34 W	16
R 310-313	221 038	Resistance	47 K $\Omega$ 0,34 W	4
R 305	221 009	Resistance	1 M $\Omega$ 0,34 W	1
R 325-329	231 366	Met.-Resistance	10 $\Omega$ 0,34 W	5
L 1-5	225 533	Lamp socket		5
	226 056	Lamps	12 V-15 V 2 W	5

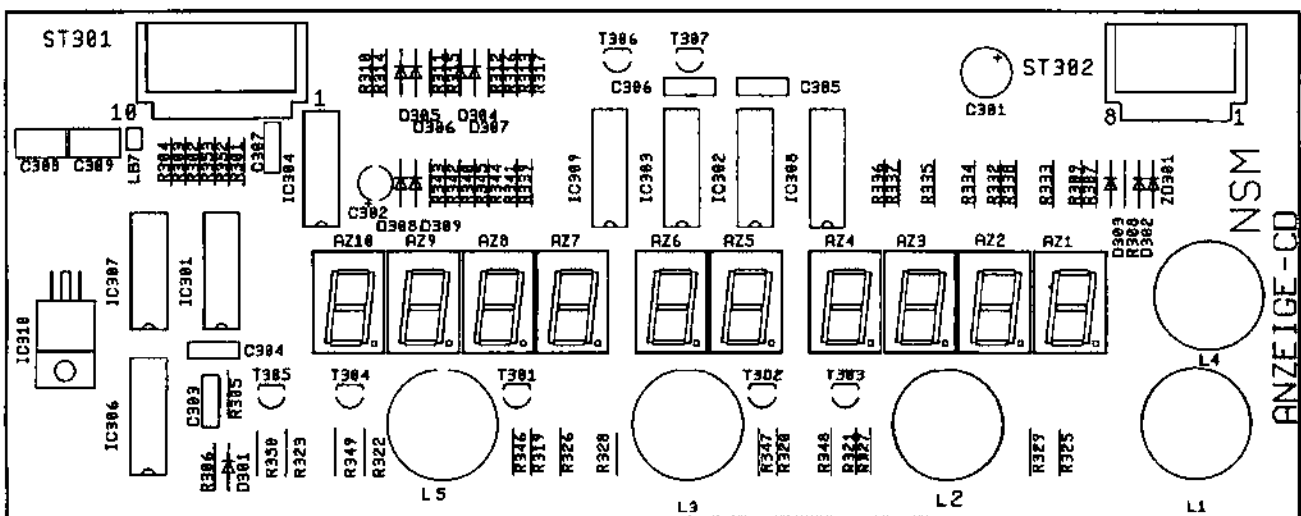

**Appendix A**

The following pages contain informations about the CD changer MBCIII-PRO.

**Technical Description**

**MBC III-PRO**

**CD-Changer  
for  
NSM Phonographs**

**Caution:**

**No user-serviceable parts inside.  
Refer servicing to qualified service personnel!**

**Disassembling parts and changing of any adjustments, apart from those specified within this manual, may result in exposure to hazardous laser radiation.**

**CLASS 1  
LASER PRODUCT**

TO IEC 825-1:1993

**Warning:** This product is a Laser Class 1 device. Disk access is carried out by using a laser beam. The laser doesn't represent any risk for the user. Any operation on the CD drives other than those defined in the user's manual should be carried out exclusively by an authorised service representative.

This product complies with DHHS Rules 21 CFR chapter 1, subchapter J, applicable at the date of manufacturing. Accession number: 95 20 184

**Note:**

The information and illustrations contained in this manual are up-to-date at the time of publication. Subject to technical modification without obligation to modify equipment already delivered!

**Version 1.0 / May 18, 1998**

Copyright by

NSM Aktiengesellschaft , D-55411 Bingen am Rhein, Germany

**No reprint in full or part unless approved!**

<b>1. General description</b> .....	<b>5</b>
Figure 1: General view to the CD changer MBC III .....	5
<b>2. Functional description</b> .....	<b>6</b>
<b>2.1 Function of the changer mechanism</b> .....	<b>6</b>
2.1.1 Lift .....	6
2.1.2 Grip .....	6
2.1.3 Grip access .....	7
2.1.4 Synchronization of the changer mechanism .....	7
<b>2.2 Driving and functioning of the CD player</b> .....	<b>7</b>
<b>2.3 Technical data</b> .....	<b>8</b>
<b>3. Settings</b> .....	<b>9</b>
<b>3.1. Setting the Gripper Reference (P158)</b> .....	<b>9</b>
Figure 2: Principle of function .....	9
<b>3.2. Setting the Lift-Reference (P159)</b> .....	<b>11</b>
Figure 3: Front view with lift in front of tray 49 .....	12
Figure 4: Keyboard layout during service program P159 .....	12
<b>3.3. Manual control of the MBC III (P157)</b> .....	<b>13</b>
3.3.1 P157.0: Manual control of the CD-changer with testing the CD-player .....	13
Figure 5: Separation of the phonograph's display for displaying the status information .....	13
Figure 6: Keyboard layout during service program P157.0 without CD on player .....	13
Figure 7: Keyboard layout during service program P157.0 with CD on player .....	14
3.3.2 P157.1: Manual control of the CD-changer without testing the CD-player .....	14
Figure 8: Keyboard layout during service program P157.1 without CD .....	14
<b>4. Exchange of components</b> .....	<b>15</b>
<b>4.1. MBC-Controller</b> .....	<b>15</b>
Figure 9: Position of IC4 on the CB "CONTROLLER-MBC III" .....	15
<b>4.2 Test for Opto Diagnosis P154</b> .....	<b>16</b>
<b>4.3 Repairs at the lift of MBC III</b> .....	<b>17</b>
<b>5. Spare parts list</b> .....	<b>19</b>
<b>6. Wiring diagrams and board layouts</b> .....	<b>29</b>

## 1. General description

The MBCIII is a CD changer for 100 audio CDs altogether. The device is equipped with a professional CD player and is constructed especially for the NSM phonograph.

It contains 2 compact CD magazines with trays for each 50 CDs with 12 cm diameter in which the CDs are kept dustfree. The magazines are easy to remove; the CDs can be exchanged comfortably and without any problem. Via the trays they are being transported carefully to the CD player, where they are being played contactlessly.

The MBCIII contains an autonomic controller which controls and surveys all functions. Via a serial interface it communicates with the control unit of the phonograph, exchanging commands and status requests.

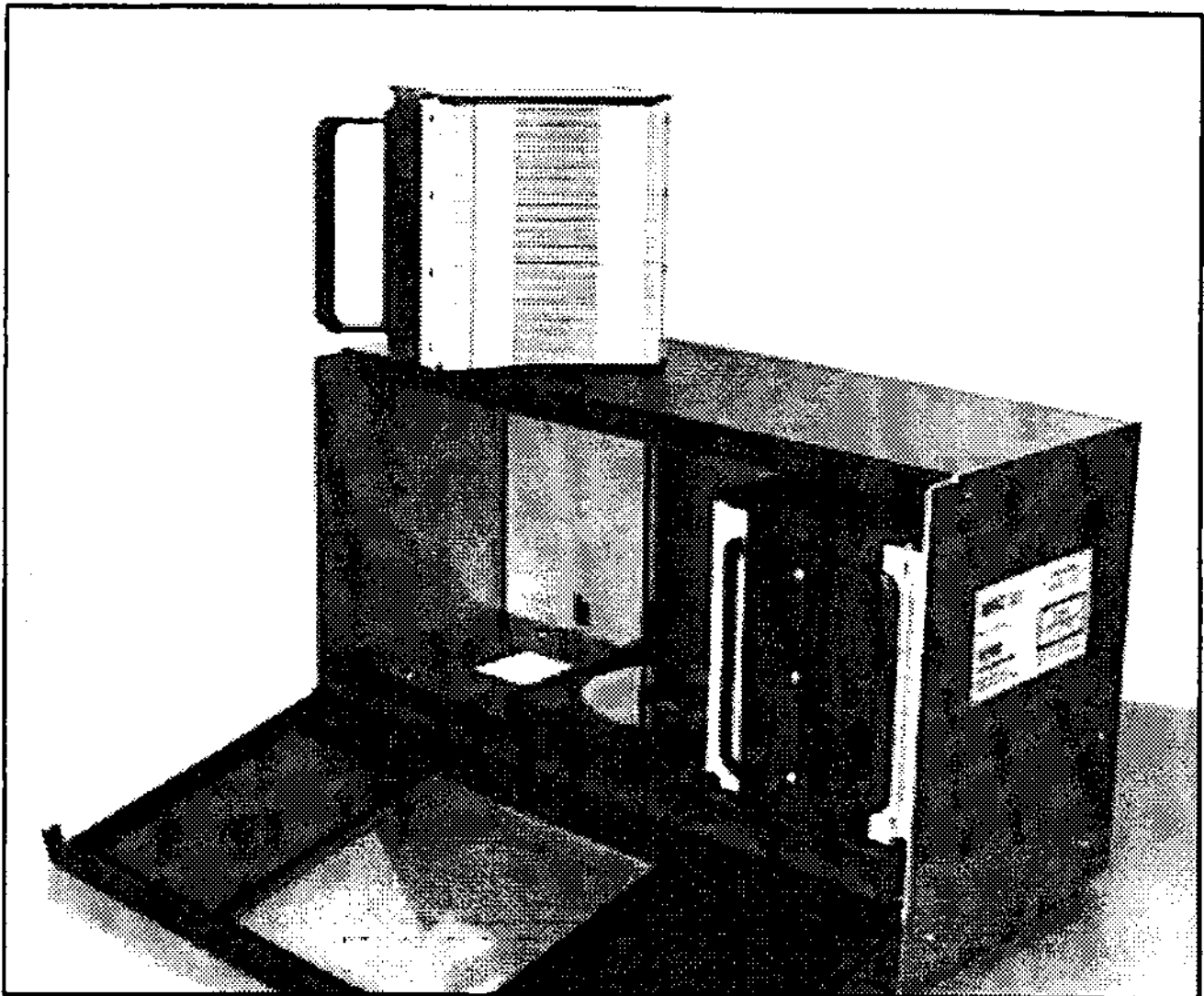

Figure1: General view to the CD changer MBC III

## 2. Functional description

The following description refers to the frontal view to the CD changer, that means view to the magazines.

### 2.1 Function of the changer mechanism

The function of the changer is based on the following motors and sensors.

Motors:

- MoLift= Stepper motor for lift movement
- MoGr= Stepper motor for grip movement
- MaGr= Selector motor for right side or left side access of the grip

Sensors:

- sLift= Optocoupler for lift synchronization
- Encoder= Optical encoder for controlling the motor "MoLift"
- sGrI= Optocoupler for grip synchronization "Inner"
- sGrO= Optocoupler for grip synchronization "Outer"
- sGrL= Optocoupler for controlling the motor "MaGr" left
- sGrR= Optocoupler for controlling the motor "MaGr" right

#### 2.1.1 Lift

The lift is driven by two lift shafts and moved up and down by the motor "MoLift" via two synchronous running belts.

Inside the lift there are no electrical drivers or sensors. All necessary electrical components are placed beneath the bottom plate (lower supporting plate).

Both lift shafts are arranged turnably and are grooved for transmitting the motor turnings to the grips and the grip access.

An eventual hindrance to or a malfunction of the lift are surveyed by the optical "Encoder".

This encoder is built up with an optocoupler and a diaphragm with 100 slits and is directly mounted on the shaft of the motor "MoLift". So every stepping error can be detected.

When the lift is moved down to the home position at the bottom of the appliance another diaphragm will darken the optocoupler "sLift" (CB OPTO). So this optocoupler can serve for synchronising the lift motor.

The upper part (cover) of the lift contains a stretching cone with an integrated toric magnet in order to press the CD on the turntable of the player. When a CD is being played no mechanical pressure is effected on the player.

#### 2.1.2 Grip

Inside the lift there are 2 gripper. They are moved in opposite direction by the "right lift leading shaft" driven by the stepper motor "MoGr". The gripper can take the positions "Inner" (tray in lift) or "Outer" (tray not in lift). Depending on the position of the switch inside the lift and during rotation of motor "MoGr" one grip (left or right) at a time engages in the groove of the tray after leaving the switch; the attached tray is transported into resp. out of the lift.

The two optocouplers "sGrI" (grip position Inner) and "sGrO" (grip position Outer) are used to synchronize the grip motor. The corresponding diaphragm (a lever) is coupled with the shift linkage. In position "Inner" the optocoupler "sGrI" and in position "Outer" the optocoupler "sGrO" will be darkened.

All optocouplers are positioned on the CB OPTO.

### 2.1.3 Grip access

The grip access selection to a tray (left hand or right hand) is defined by the position of motor "MaGr". This motor works like a "twin magnet" which moves a switch inside the lift in a motor angle of 18° via the left lift shaft. Depending on the position of this switch (left or right) the grip access to the tray is controlled. Two optocouplers "sGrL" or "sGrR" are used to monitor the correct functioning of the change mechanism. Depending on the position of the switch one of these two optocouplers is darkened by a lever (CB OPTO).

### 2.1.4 Synchronization of the changer mechanism

The two stepper motors "MoLift" for lift movement and "MoGr" for grip movement are synchronized via optocouplers (sLift, sGrL, sGrO). The points of synchronization are automatically requested by the MBC-controller while power on. The distance (measured in motor steps) between the mechanical reference point and the respective synchronization point is "learned" automatically while the controller is in "learn mode". Therefore the mechanism must be positioned manually to the mechanical reference point. Afterwards one "learn run" must be performed by executing the corresponding service program step via display/keyboard. The detected values are stored in the non-volatile memory chip IC4 of the MBC-controller.

The setting of the synchronization points is already completed in the factory and does not have to be repeated. A new setting of the synchronization points becomes necessary after:

- An unacceptably tight mechanical hit
- Exchange of lift or grip mechanism
- Exchange of parts of the driver mechanism
- Exchange of the "CB OPTO"
- Exchange of the "CB CONTROLLER"
- Exchange of the memory chip IC4 (on CB CONTROLLER)

Refer to "Setting the grip- and lift reference".

## 2.2 Driving and functioning of the CD player

The CD player is a professional "PHILIPS CD-Pro" CD drive.

This drive is mounted vibration-free on the lower side of the changer's mounting plate.

The whole electronics (servo, decoder, D/A changer) of the CD player are placed directly below the CD drive.

Via a serial interface the MBC controller communicates with the controller of the CD player.

Thereby all necessary commands and status information of the player are transmitted.

A steel plate stretching the CD is pressed into the turntable. It serves as antipole for the toric magnet within the stretching cone placed in the upper part of the lift.

The CD is being pressed magnetically, that means contactlessly, onto the turntable of the player.



## 2.3 Technical data

### Power supply:

Mains voltage:	+28V DC $\pm$ 15% / 1.5A
	+14V DC $\pm$ 15% / 1A
	+5V DC $\pm$ 10% / 0.6A

### Operating conditions:

Ambient temperature:	5° to 45° C, operating
	-25° to 55° C, storage
Relative humidity:	5% to 90%, operating
(non-condensing)	5% to 95%, storage

### Dimensions and Weight:

Height:	275 mm
Width:	465 mm
Depth:	220 mm
Weight (without CDs):	11.3 kg

### Magazines/Trays:

Number of magazines:	2
Dimensions:	160(H)x150(B)x180(T) mm
Number of trays:	50 per magazine
Dimensions:	3(H)x151(B)x137(T) mm

### Robotic:

Media swap time:	1.2 sec.
Media swap time:	2.5 sec.
Media exchange time:	2 sec. (average)

### CD Drive:

Brand:	PHILIPS CD-Pro
Applicable disc format:	Red-book
Rotational speed:	approx. 200 to 530 rpm
MTBF (Mean Time Between Failures):	30,000 power-on hours

### Audio specification:

Output level:	1.5 V <sub>eff</sub>
Output impedance:	100 $\Omega$
Frequency range:	20Hz - 20KHz
Noise voltage ratio:	-90 dB
Channel separation:	-89 dB
K-factor:	-85 dB

### 3. Settings

#### 3.1. Setting the Gripper Reference (P158)

Before setting the gripper reference please read the chapter "Function of the changer mechanism" first for a better understanding of the subject.

1. At first it has to be checked whether the diaphragm coupled with the shift linkage symmetrically darkens the two optocouplers "sGrI" and "sGrO". Remove the magazines from the CD changer. Place the unit upside down on the table and disassemble the bottom tub.
2. Move the diaphragm wheel manually by turning the flywheel of the grip motor first to one and then to the other stop. Check if the diaphragm symmetrically darkens the optocouplers "sGrI" and "sGrO" in the two final positions (stream of light interrupted).

The rough setting is done by applying the driver toothed belt.

The fine adjustment may be changed by loosening the clamping screw at the diaphragm wheel.

After checking or setting the grip rough adjustment put the CD changer once again into its correct position and re-insert the magazines.

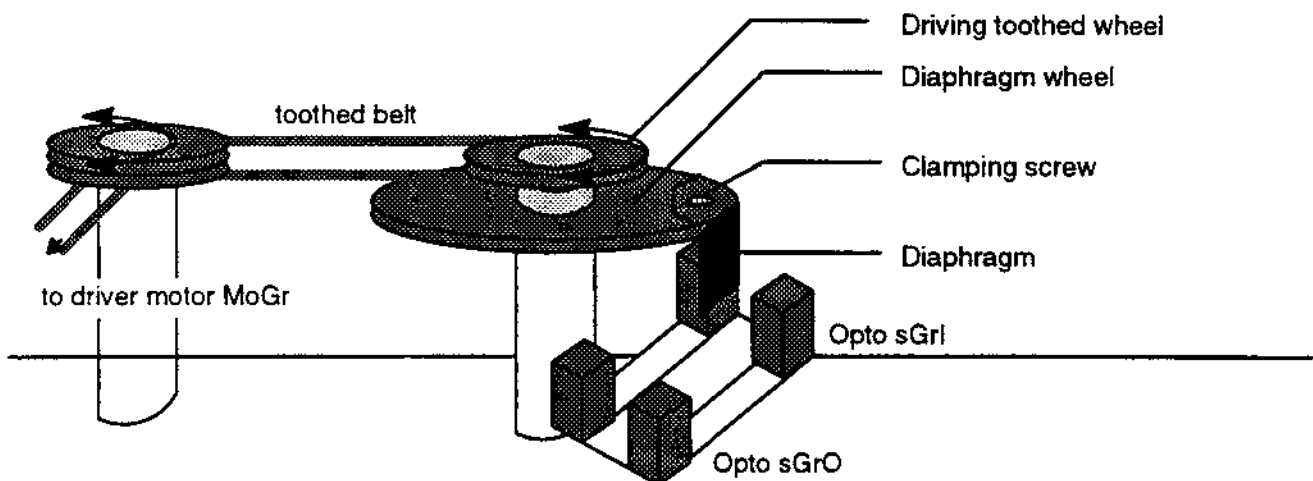

Figure 2: Principle of function

3. Connect the device with the phonograph.  
Enter service mode by pulling out the service switch.  
Enter **158+H**                      Display shows: **P158** \_ \_ \_
4. Enter **0**                              Display shows: **P158** \_ **1418** (for example)  
The display shows the actually stored synchronisation values for the grippers (outer distance = 18 motor steps, inner distance = 14 motor steps).
5. Enter **H**  
The grippers are moved automatically to the "outer position".  
Display shows: **P158** \_ \_ **0**

6. Enter H

Grippers are moved automatically to the "inner position".

Display shows: P158 \_\_ \_\_ 1

7. Enter H. The new reference values will be evaluated and the grippers are moved to the outside position.

The display shows the new synchronisation values, for example: P158 \_\_ 1517 (outer distance = 17 motor steps, inner distance = 15 motor steps).

8. Enter H

The new values are saved to memory.

**Note:** For best functionality of the changer the displayed values must be in a range from 12 to 25. The difference between the two displayed values must be  $\leq 5$  (maximum display "P158 ..1217" or "P158 .. 2025).

9. Enter H. The next service program step is entered.

Display shows: P159 \_\_ \_\_

The setting of the gripper reference is now terminated.

If the values are outside the allowed tolerances, the error lamp will blink and the old values are unchanged.

The program may be interrupted at any stage previous to step 8. by pressing the C button on the keypad. The original values will be unchanged.

Alternatively to this step-by-step routine you can use an automatic routine:

1. Call up the service program as usual (P158 +H)

2. Enter 1 + H

The automatic routine is started. The evaluated values will be directly saved to memory.

3. Enter H. The next service program step is entered.

Display shows: P159 \_\_ \_\_

### 3.2. Setting the Lift-Reference (P159)

For a better understanding first read the chapter "Function of the changer mechanism".  
The setting of the lift refence should be performed after setting the grip reference (no tray in the lift).

The setting of the lift is performed without any mechanical adjustment.

The vertical distance from the lower bottom plate up to the synchronization mark (sLift) is stored automatically by starting the service menu. A control and possible height correction is performed in front of tray 49.

1. Connect the CD-changer with the phonograph. Enter service mode by pulling out the service switch.  
Enter **159+H**                      Display shows: **P159** \_ \_ \_ \_
2. Enter **0**                              Display shows: **P159** \_ **2902** (for example)  
The display shows the stored distance between bottom plate and optocoupler sLift (29).  
The value **02** denotes that, during the previous adjustment, the lift was set 2 (two) steps higher.
3. Enter **H**  
The lift will automatically synchronize at the position "optocoupler sLift" and afterwards the stepper motor tries to move the lift against the bottom plate.  
Display shows: **P159** \_ \_ \_ **0**
4. Enter **H**  
The lift is moved automatically to tray 49 (reference tray). Now you can perform corrections of the lift position corresponding to the position of tray 49 (see figure 4).  
Display shows: **P159** \_ \_ \_ **00**
5. Use the keyboard of the phonograph to manually grip or to put back a CD tray (see figure 4).  
The lift can be moved in single steps up or down. There-by the actual height correction value is displayed (e.g.: "P159 . . . .01").  
The gripper can be moved manually by turning the right lift leading shaft.
6. Enter **H**  
The displayed height correction value is saved to the non-volatile memory IC4.  
The setting of the lift reference is now terminated. The lift moves back to the bottom plate.  
If an error occurs while moving or if the height correction value is > 10 the "error" lamp will blink and the old value is unchanged.
7. Enter **H**                              Display shows: **P160** \_ \_ \_ \_  
The program steps to the next service program step.

Pressing the **C** button on the keypad at any stage (1. to 7.) will interrupt this program step and the original values are unchanged.

Alternatively to this step-by-step routine you can use an automatic routine:

1. Call up the service program step "P159" (P159 +H)
2. Enter **1 + H**.  
There is no pause between synchronisation at the bottom plate and moving to the reference position (tray 49).
3. Use the keyboard of the phonograph to manually grip or to put back a CD tray (see figure 4).  
The lift can be moved in single steps up or down. There-by the actual height correction value is displayed (e.g.: "P159 . . . .01").  
The gripper can be moved manually by turning the right lift leading shaft.

4. Enter H  
The displayed height correction value is saved to the non-volatile memory IC4.  
The setting of the lift reference is now terminated. The lift moves back to the bottom plate.  
If an error occurs while moving or if the height correction value is > 10 the "error" lamp will blink and the old value is unchanged.
5. Enter H                      Display shows: P160 \_\_\_\_\_  
The program steps to the next service program step.

Pressing the C button on the keypad at any stage (1. to 5.) will interrupt this program step and the original values are unchanged.

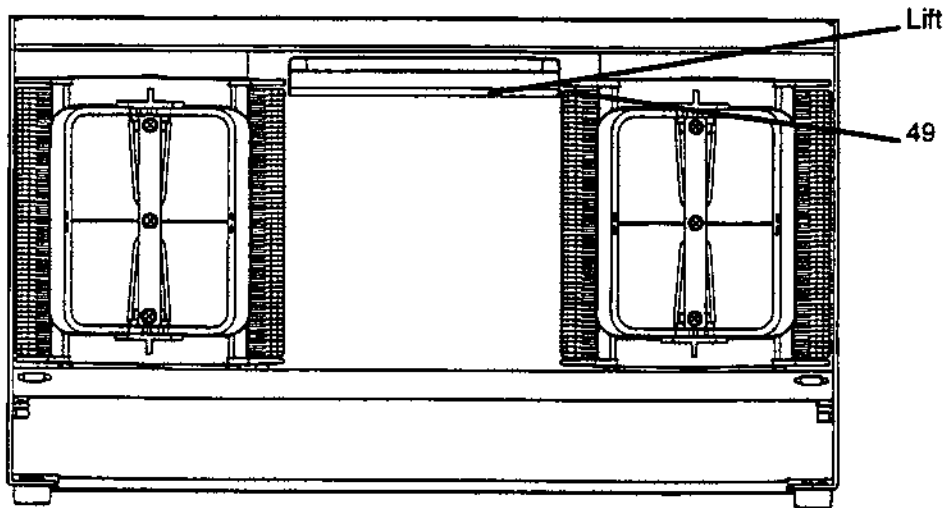

Figure 3: Front view with lift in front of tray 49

During the service program step P159 the keyboard of the CD changer serves the following functions:

- 1: not used
- 2: not used
- 3: Drive lift one motor step upwards
- 4: Grip tray from left magazine
- 5: Insert tray into magazine
- 6: Grip tray from right magazine
- 7: not used
- 8: not used
- 9: Drive lift one motor step downwards
- 0: not used
- C: Cancel procedure
- H: Store displayed lift correction value





1	2	 3 Lift 1 step up
 grip CD from left 4	 put CD back 5	 grip CD from right 6
7	8	 9 Lift 1 step down
C Cancel	0	H Store corrected values

Figure 4: Keyboard layout during service program P159

### 3.3. Manual control of the MBC III (P157)

For checking the functions of the "MBC III" it may be controlled manually using the service program step "P157".

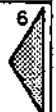
#### 3.3.1 P157.0: Manual control of the CD-changer with testing the CD-player

After selection of the service program step "P157" the status of the optocouplers of the "MBC III" will be displayed on the phonograph's display:

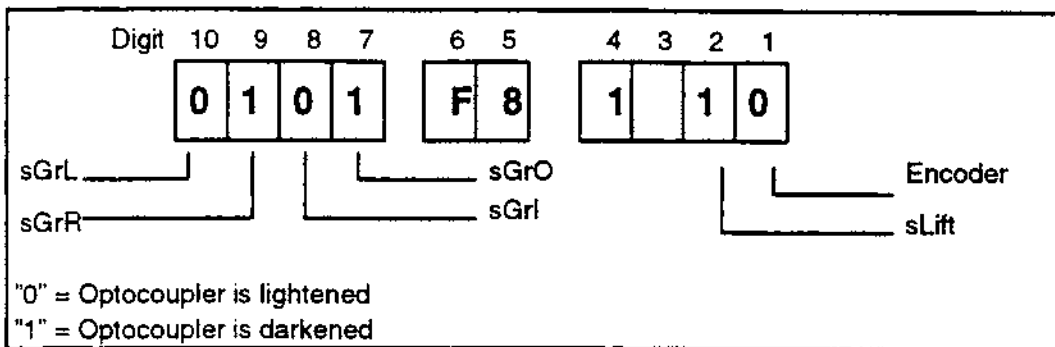

Figure 5: Separation of the phonograph's display for displaying the status information

During "P157.0" the keypad buttons of the phonograph serve the following functions if no CD is placed on the CD-player:

#### A: No CD on player

- 1: not used
- 2: Drive lift upwards
- 3: Drive lift one motor step upwards
- 4: Grip tray from left magazine
- 5: Insert tray into magazine
- 6: Grip tray from right magazine
- 7: not used
- 8: Drive lift downwards
- 9: Drive lift one motor step downwards
- 0: Insert tray into magazine  
Drive lift in home position
- C: Leave service program
- H: not used

1	2 Lift up	3 Lift up stepwise
4 Grip CD from left	5 Put CD back	6 Grip CD from right
7	8 Lift down	9 Lift down stepwise
Cancel	0 Put CD back, lift downwards	H

Figure 6: Keyboard layout during service program P157.0 without CD on player

During "P157.0" the keypad buttons of the phonograph serve the following functions if a CD is placed on the CD-player:

**B: CD on player**

- 1: CD-Player Start/Pause
- 2: Fast play forward
- 3: Play next track
- 4: Put last CD on player
- 5: Insert tray into magazine
- 6: Put the next CD on player
- 7: not used
- 8: Fast play backward
- 9: Playing of the last track
- 0: Stop / Return CD
- C: Leave the service program
- H: Change to the next service program

1 CD-Player Start/Pause Stop Fast play	2 Fast play forward	3 Play next track
4 Put CD back grip last one	5 Insert tray into magazine	6 Put CD back, grip next one
7	8 Fast play backward	9 Play next title
C Cancel	0 Stop CD, return CD	H

Figure 7: Keyboard layout during service program P157.0 with CD on player

**3.3.2 P157.1: Manual control of the CD-changer without testing the CD-player**

The keypad layout for P157.1 is nearly the same as for P157.0 without CD (see figure 6). Additionally the lift motor can be set to a currentless state thus to move the motor manually to check the lift for stiffness. Use key "1" or "7" to switch between left and right magazine to pick a CD-tray. Use key "H" to center the lift to the next CD-tray in a magazine.

**Manual control**

- 1: Put selector motor "MaGr" to left hand access
- 2: Move lift upwards
- 3: Move lift upwards in single steps
- 4: Grip CD-tray from the left magazine
- 5: Put CD-tray back into magazine
- 6: Grip CD-tray from the right magazine
- 7: Put selector motor "MaGr" to right hand access
- 8: Move lift downwards
- 9: Move lift downwards in single steps
- 0: Set lift motor to currentless state
- C: Cancel
- H: Center lift to the next CD-tray

1 Put selector motor MaGr to left	2 Lift up	3 Lift up stepwise
4 Grip CD from left	5 Put CD back	6 Grip CD from right
7 Put selector motor MaGr to right	8 Lift down	9 Lift down stepwise
C Cancel	0 Lift motor currentless	H Center lift to next CD-tray

Figure 8: Keyboard layout during service program P157.1 without CD

Press C to leave service program step P157.1.

## 4. Exchange of components

**Caution:** Before exchanging a unit or demounting parts of the device, pull out the phonograph's mains connection first!!

### 4.1. MBC-Controller

When exchanging the CB CONTROLLER-MBC III please consider the following:

The memory chip IC4 located on the CB stores all necessary non-volatile data as

- Lift reference
- Gripper reference
- Number of tray inside the lift.

Take care that before the exchange of the CB CONTROLLER no tray remains inside the lift (if necessary push out manually by turning the left lift shaft).

After exchange of the CB the lift and gripper reference have to be readjusted. Therefore see chapter 3 (Settings).

In case that the memory chip IC4 on the disassembled CB is still o.k., it can be pulled out of its socket and exchanged with the one on the newly assembled CB. The previous adjustments are then preserved and do not have to be repeated.

After the exchange of the MBC-Controller verify all functions of the device.

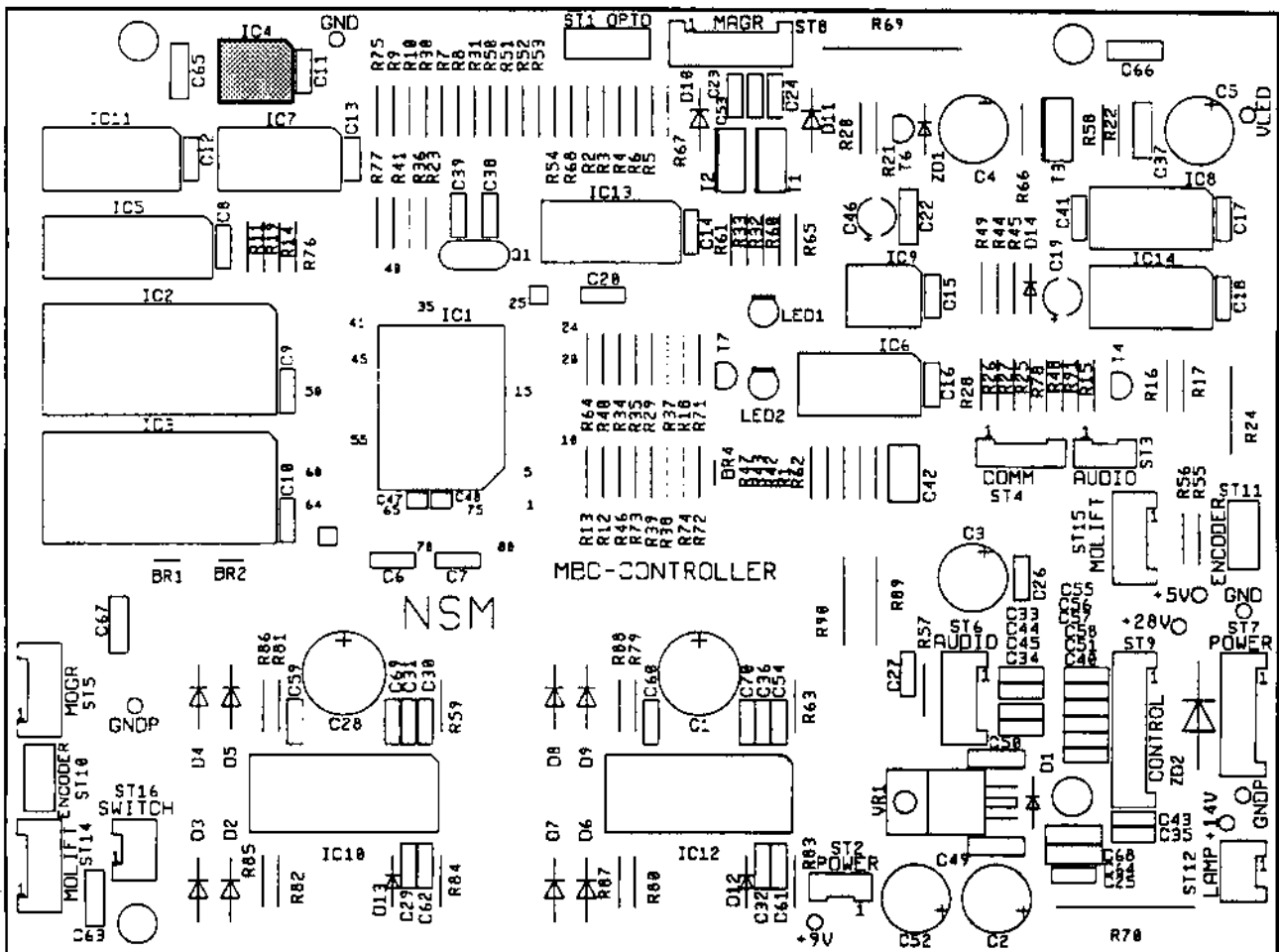

Figure 9: Position of IC4 on the CB "CONTROLLER-MBC III",



## 4.2 Test for Opto Diagnosis P154

The MBC III CD changer is built in a way which offers the possibilities to check each optocoupler with service program step P154. Using this program step, it is possible to tell if any of the 5 optos in the MBC III changer is performing poorly. This is done as follows:

- Open the phonograph and enter the service mode by pulling out the service switch.
- Press **C** on the keypad.
- Press **154 H 0**.
- The MBC III changer will then check each opto in succession by performing certain lift movements. Afterwards, a relative value denoting the supply voltage is displayed. This number should be between **165** and **195**.
- Now check each optocoupler by pressing the corresponding key:

Key 1 = sLift opto.	Value should be between <b>25</b> and <b>80</b> . Otherwise, change opto.
Key 2 = sGrO opto.	Value should be between <b>25</b> and <b>80</b> . Otherwise, change opto.
Key 3 = sGrI opto.	Value should be between <b>25</b> and <b>80</b> . Otherwise, change opto.
Key 4 = sGrR opto.	Value should be between <b>15</b> and <b>75</b> . Otherwise, change opto.
Key 5 = sGrL opto.	Value should be between <b>15</b> and <b>75</b> . Otherwise, change opto.

**Note:** This test is a performance test, and requires all optos to be at least minimally functional. If there is the value "100", so the corresponding opto may be dead. Is the opto coppler illuminated with stray light, a value of "00" is determined. In this case, cover the opto during the test.

### 4.3 Repairs at the lift of MBC III

Removal and installation are carried out as follows.

#### Removal:

1. Remove the frontal cover.
2. Take out the magazines.
3. Remove the screws on the backside of the device.
4. Loosen the upper and the two backwards located screws of the right and the left side wall. Lift off the L-shaped outer plate.
5. Lay down the device upside-down and remove the four holding screws. Take off the bottom plate.
6. Remove the both Benzing lock washers from the ends of the lift spindles and take out the washers.
7. In order to remove the selector motor (MaGr) pull out its mains connector and loosen the fixing screws from the motor end shield.
8. Loosen the grip motor and remove the toothed belts from the right lift spindles.
9. In order to take out the right toothed belt remove the right Benzing lock washer from the spindle axle. Hold the toothed belt in position and push its washer to the right hand side.
10. Replace the device in upright position, remove the bearing housing from the upper mounting plate and pull out to the top the lift spindles (thereby also pull out the switch of the left lift spindle).
11. Place the device on the front side and loosen the supporting screws; open both rocking levers to slacken the toothed belts.
12. Take the toothed belts off the toothed wheel and push the loops deeper into the gaps of the lower mounting plate so that now you can remove the toothed belts from the lower wheels.
13. Take the lift out of the device.
14. For removal of the two toothed belts take their ends out of the holding clamps of the lift.

**Installation:**

15. After having pressed in the ends of the toothed belts with 4 teeth insert the lift into the device so that the NSM logo is frontally located.
16. The lift spindle with the twice stepped ends has to be pushed carefully turning from the front through the upper mounting plate and the bearings of the lift, so that the carrier springs in the lift bearings correspond to the groove of the spindles, and then through the bearings into the lower mounting plate. The left lift spindle synchronically has to be inserted into the switch of the selector motor.
17. Insert the upper bearing housings with the spring washer and screw down the bearings.
18. Place the paired ends of the lower toothed belts around the two lower belt washers, so that the lift can be pulled parallelly to the mounting plate.
19. Adjust the belt tension with the belt stretchers and fix it with the supporting screws.
20. Place the device upside-down.
21. Lock the switch at the left lift spindle with washer and locking washer.
22. Screw down the selector motor with the fixing screws. Insert the control lever with its plug into the slot of the switch lever. Take care that friction only emerges within the slot. Therefore insert distance sleeves. The switch lever has to be placed in its final position.
23. Place the double stepped driving wheel on the right lift spindle so that the bigger wheel is located in direction of the lift spindle on the inner side.
24. Replace the toothed belt and remount the grip motor.
25. Turn the flywheel of the grip motor to the left side up to the stop and the switch segment control wheel with a lefthand rotation into the left optocoupler so that the segment (diaphragm) will almost darken the range of this optocoupler.
26. Place the toothed belt in this position onto the smaller belt wheel.
27. Secure the toothed belt wheel with the Benzing lock washer after having mounted the flanged wheel.
28. Turn the flywheel to the right hand side up to the stop. The switch segment control wheel must darken the right optocoupler.
29. By turning the control wheel several times into its final position check the position of the switch segment (diaphragm) with regard to the two optocouplers. Make sure that the darkening of the optocouplers in the final position is symmetrically. The switch segment is connected with the control wheel by a long hole so that a fine adjustment can be made.
30. Place the toothed belt for the lift transportation onto the belt wheel, fit the 4 fifth-wheel king pins into the counterpart located on the spindle, and replace the Benzing lock washer.
31. Place the device face up and adjust the grip- and lift reference (see section adjustment of grip- and lift reference).
32. Verify the functioning of the device and remount the bottom- and the outside plates.

**5.Spare parts list:**

Pos.	Part-No.	Description	Data	Quantity.
	179 530 *	CD-CHANGER MBC III-PRO, w/o magazine		1
X	140 285	Shock absorber <i>(Before installing the CD-changer into a Sapphire you must remove the shock absorbers.)</i>		4
1	178 136	Magazine w/o disc holder		2
2	140 024	Disc holder single	Tablett	50
3	140 218	Front door, complete	(with plate)	1
4	140 212	Plate	single	1
5-8	179 456	Cabinet plate, pasted MBC III		1
5	179 460	Cabinet plate		1
6	212 958	Mirror MBC III		1
7	212 939	Cover plate		1
8	179 437	Design foil MBC III, blue		1
	300 264	Scotch tape 6mm white	560mm long	1

\* = Exchange unit

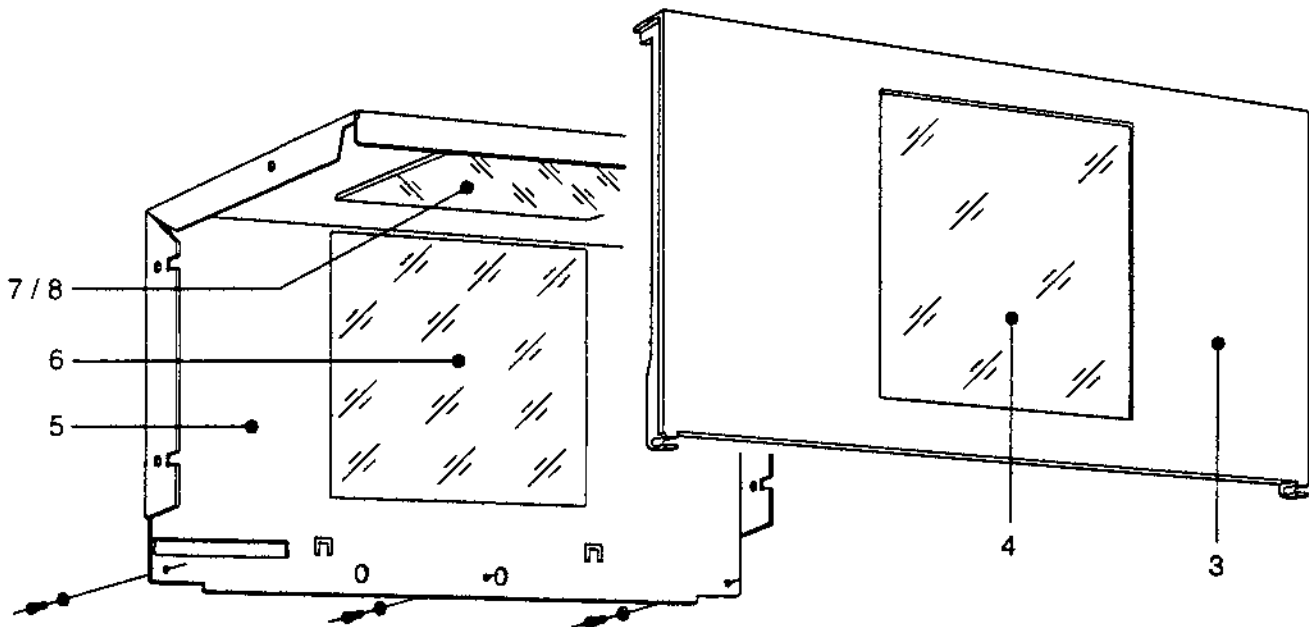

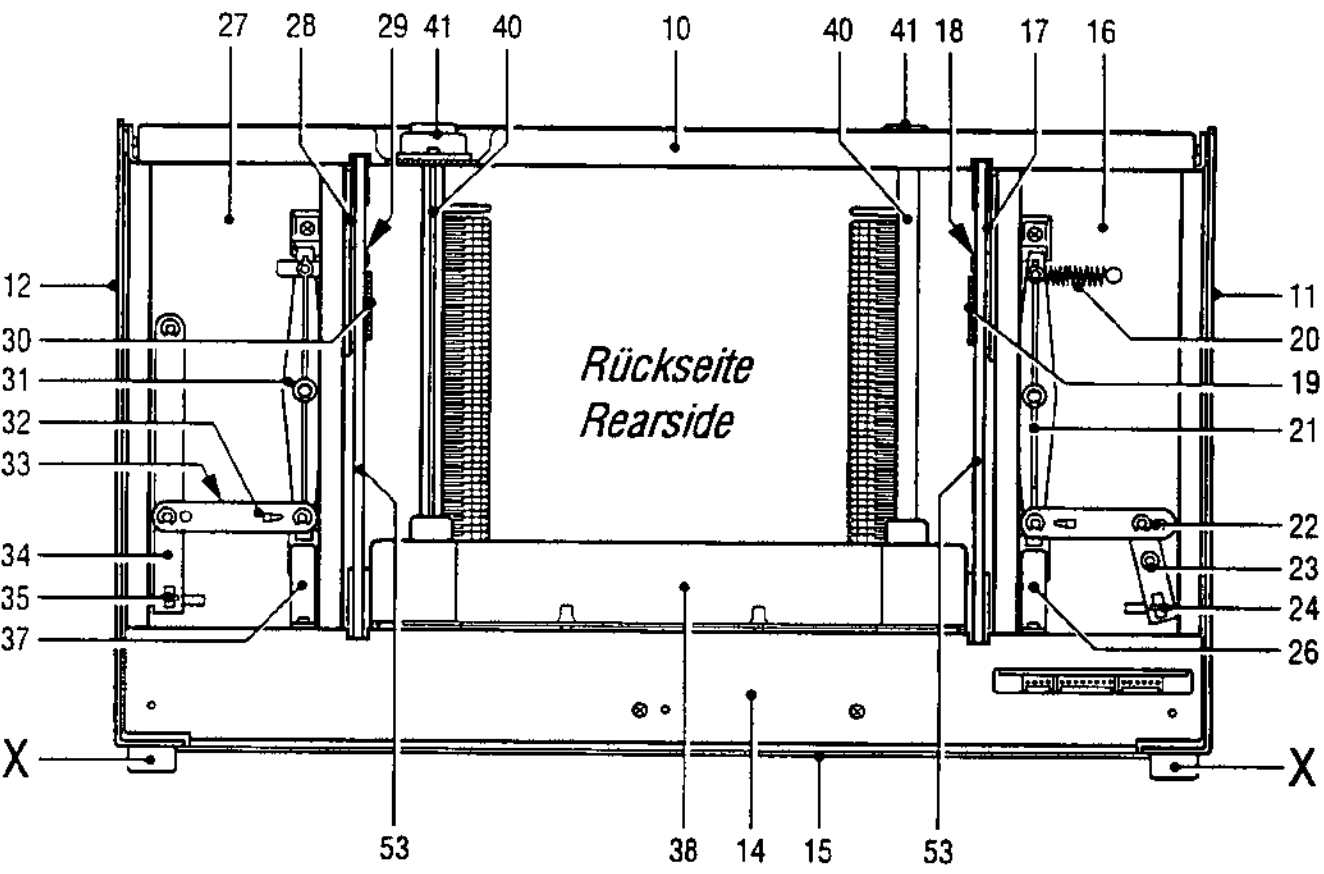
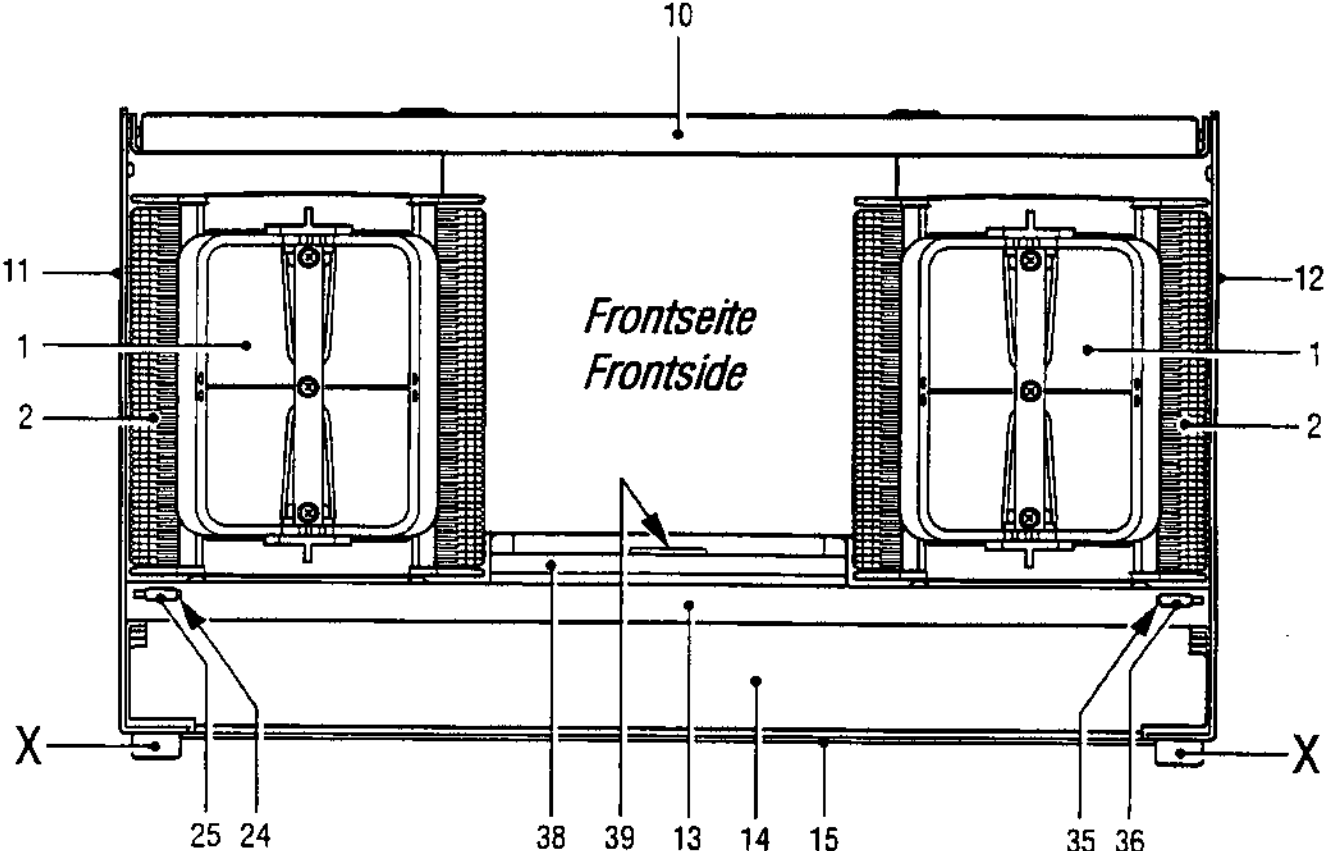

Pos.	Part-No.	Description	Data	Quantity.
10	179 182	Lid		1
11	179 188	Side wall left, riveted		1
12	179 189	Side wall right, riveted		1
13	140 315	Back plate, complete		1
14	179 184	Base plate, riveted		1
15	140 265	Base plate		1
16	179 128	Profile left, riveted		1
17	141 135	Guide plate, riveted		1
18	141 140	Guide ring		1
19	205 614	Tension spring	Guide plate	1
20	205 877	Tension spring	magazine	1
21	140 082	Catch lever left, mounted		1
22	140 058	Connection lever		1
23	140 080	Connection piece short, riveted		1
24	140 055	Opening lever		1
25	140 054	Cap		1
26	140 234	Leaf spring		1
27	179 185	Profile right, riveted		1
28	141 135	Guide plate, riveted		1
29	141 140	Guide ring		1
30	205 614	Tension spring	Guide plate	1
31	140 083	Catch lever right, mounted		1
32	140 058	Connection lever		1
33	205 877	Tension spring	magazine	1
34	140 081	Connection piece long, riveted		1
35	140 055	Opening lever		1
36	140 054	Cap		1
37	140 234	Leaf spring		1
38	140 313	Lift, complete	MBC III	1
39	140 221	Protective plate, complete		1
40	180 754	Bar	lift	2
41	140 127	Bearing housing, mounted		4

*Von unten gesehen*  
*Bottom view*

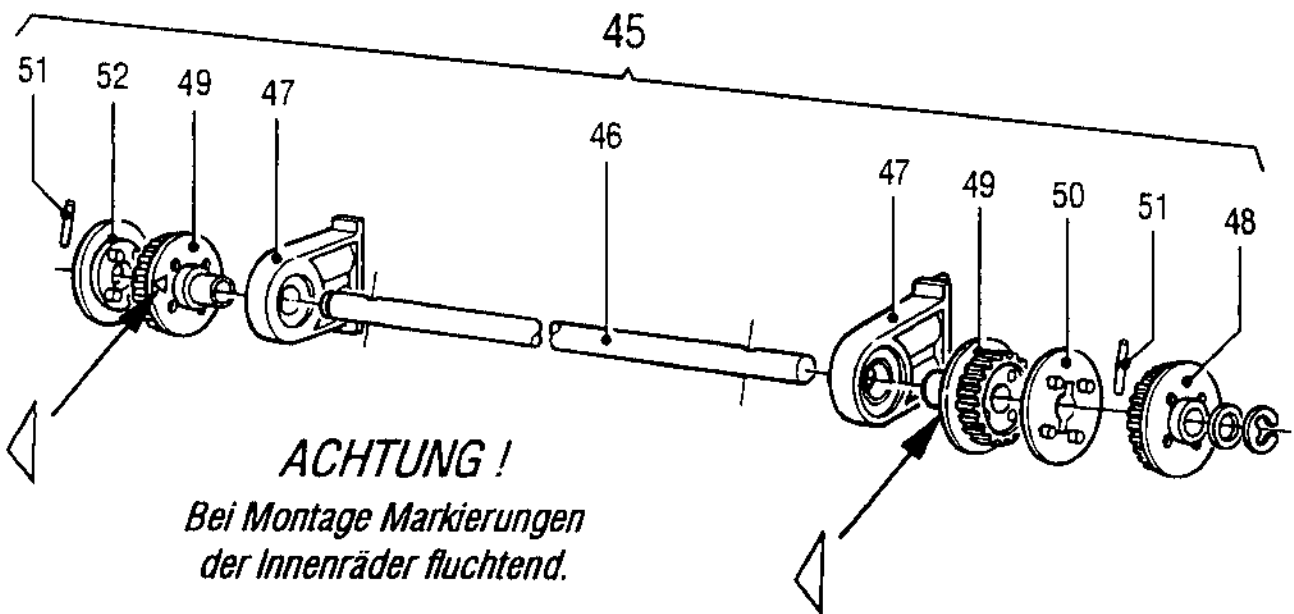
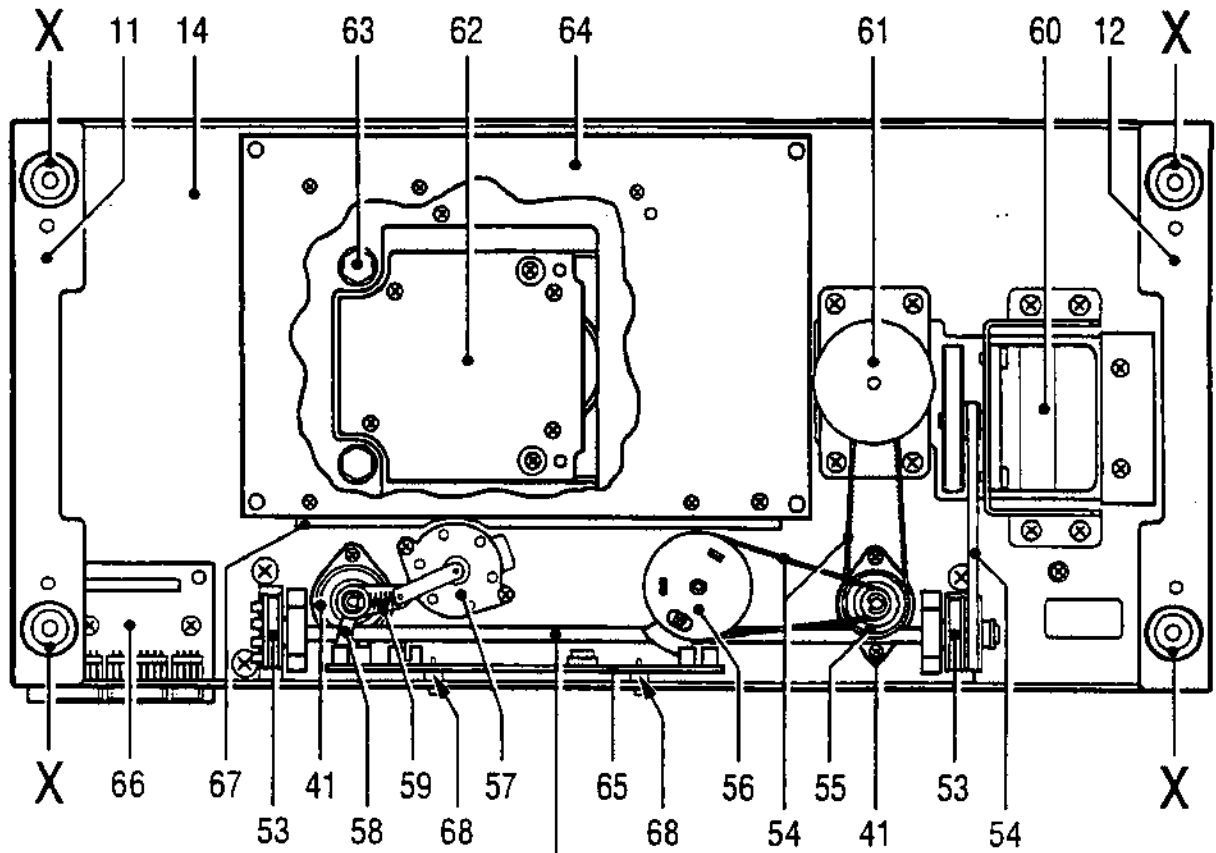

**ACHTUNG !**

*Bei Montage Markierungen  
der Innenräder fluchtend.*

**ATTENTION !**

*Observe the alignment of the  
signs on the inner toothed wheels.*

Pos.	Part-No.	Description	Data	Quantity.	
45	140 139	Bar, mounted	driving axle	1	
46	211 723	Bar		1	
47	140 162	Bearing block, mounted		2	
48	140 172	Outer wheel	Z 40	1	
49	140 173	Inner wheel	Z 25	2	
50	140 174	Transmission washer		1	
51	726 013	Needle rolle	B2,0 x 13.8	2	
52	179 167	Pivot washer		1	
53	216 283	Toothed belt	3MR-492	lift	2
54	216 281	Toothed belt	2MR-224		3
55	140 175	Driving wheel II, mounted		1	
56	140 128	Control wheel, complete		1	
57	140 150	Motor, mounted		1	
58	140 148	Switch lever		1	
59	205 892	Tension spring		1	
60	178 743	Motor 23 LM, complete		1	
	178 641	Distance piece	for motor	4	
61	178 744	Motor 17 PM, complete		1	
	178 641	Distance piece	for motor	4	
62	179 195 *	CD-Player CD-PRO, mounted		1	
63	140 321	Rubber base, mounted		4	
64	178 963 *	CB CONTROLLER - MBC III	see page 25	1	
65	179 192	CB OPTO, complete	see page 27	1	
66	179 193	CB ADAPTER MBC III, complete		1	
67	179 063	Isolating plate	CB CONTROLLER	1	
68	179 054	Spacer bolt	CB OPTO	2	
	227 642	Cable set for CD-Player	Power	4 pin	1
	227 642	Cable set for CD-Player	Audio	4 pin	1
	227 643	Cable set for CD-Player	DSA	6 pin	1
	140 243	Cable harness Encoder	250 mm long	6 pin	1
	140 238	Cable harness OPTO	80 mm long	8 pin	1

\* = Exchange unit



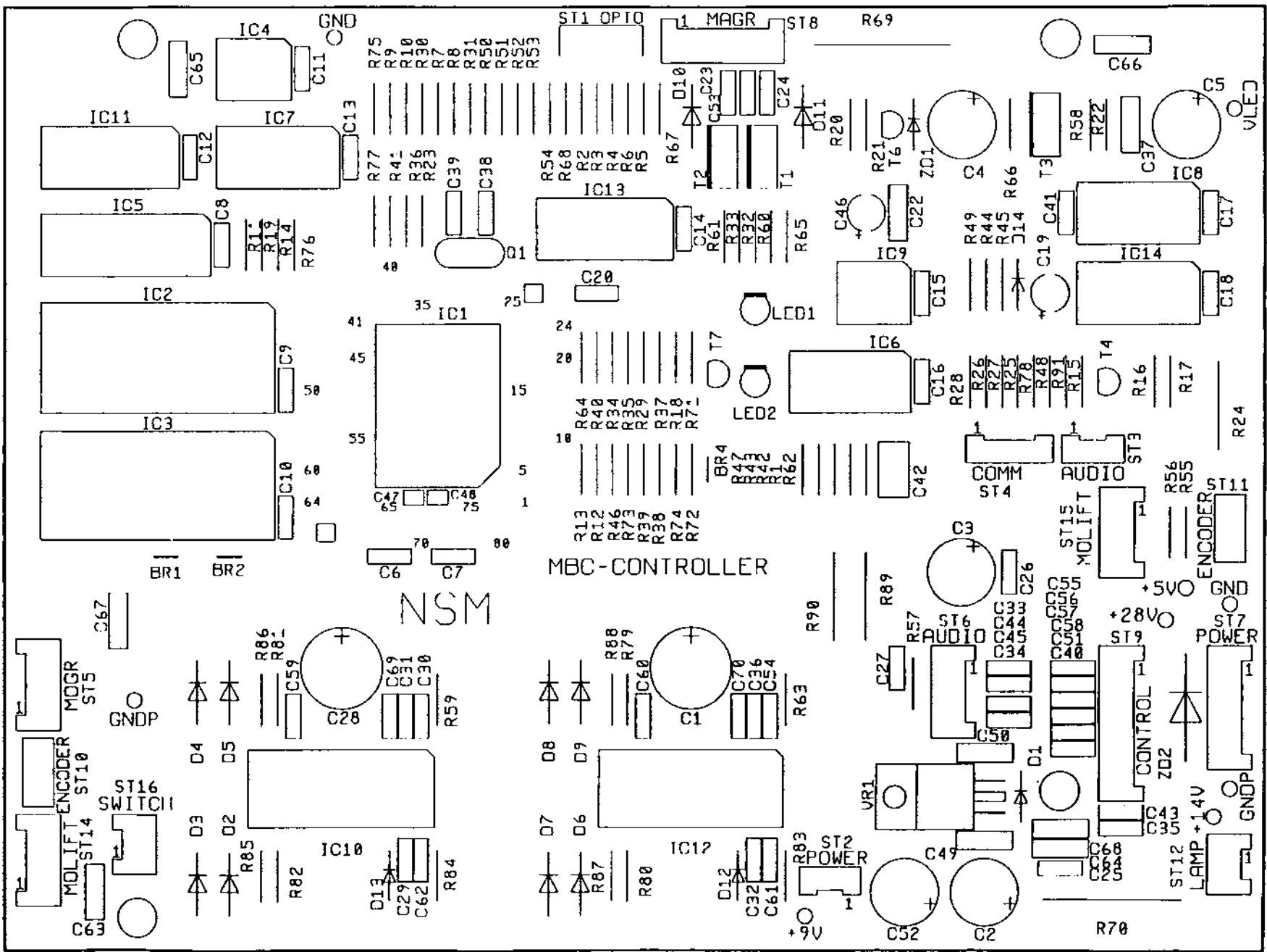

Pos.	Part-No.	Description	Data	Quantity
	<b>178 963 *</b>	<b>CB CONTROLLER-MBC III, assy</b>		<b>1</b>
	140 275	Distance plate		1
ST2, 3	235 120	Pin plug	straight 4 pin	2
ST4	235 121	Pin plug	straight 6 pin	1
ST10, 11	225 872	Socket	AMP-Micro-Match 6 pin	2
ST1	235 074	Socket	AMP-Micro-Match 8 pin	1
ST12	225 650	Pin panel	standing 2 pin	1
ST5, 6, 14, 15	225 651	Pin panel	standing 4 pin	4
ST7, 8	225 652	Pin panel	standing 6 pin	2
ST9	225 653	Pin panel	sandingt 8 pin	1
<b>Semiconductors:</b>				
IC 1	231 791	IC-Micro computer	M37732S4BFP	1
IC2	140 371	IC-Memory	programmed	1
IC2	222 447	IC-Socket	28 pin	1
IC3	231 444	IC-Memory	HM6264-LP-12	1
IC3	222 447	IC-Socket	28 pin	1
IC4	231 792	IC-Memory	FM24C04	1
IC4	222 307	IC-Socket	8 pin	1
IC6	231 633	IC-Logic	PC74HC08P	1
IC7	231 632	IC-Logic	PC74HC02P	1
IC8	231 808	IC-Logic	74HC393	1
IC11	231 804	IC-Logic	74HC139	1
IC13	221 810	IC-Logic	HEF4050BP	1
IC14	231 809	IC-Logic	74HC74	1
IC5	231 807	IC-Logic	74ALS245	1
IC9	231 431	IC-Interface	TL7705ACP	1
IC10, 12	231 794	IC-Motor driver	PBL 3774	2
VR1	231 806	IC-Voltage regulator	L4940V85	1
Q1	231 567	Quarz	16 MHz	1
T1, 2, 3	231 150	Darlington-Transistor	NPN TIP130	3
T4	221 459	Si-Transistor	PNP BC556B	1
T6, 7	221 757	Si-Transistor	NPN BC547B	2
LED1, 2	221 466	Luminescence-Diode	TLUR 440.1	2
ZD1	221 512	Si-Zener-diode	ZPD 12	1
ZD2	221 539	Transzorb diode	IC TE-5	1
D2 - D11	231 863	Si-diode	UF 4004	10
D1, 12, 13, 14	221 114	Si-diode	1N4148	4

\* = Exchange unit

Pos.	Part-No.	Description	Data	Quantity
<b>CB CONTROLLER-MBC III, continued</b>				
<b>Capacitors:</b>				
C46	220 159	Electrolytic capacitor	4,7 $\mu$ F 63V	1
C19	220 249	Electrolytic capacitor	1 $\mu$ F 63V	1
C2, 3, 4, 5, 52	220 250	Electrolytic capacitor	100 $\mu$ F 25V	5
C1, 28	220 551	Electrolytic capacitor	470 $\mu$ F 40V	2
C20, 38, 39, 41	220 266	Ceramic capacitor	27 pF 400V	4
C40, 43, 44, 45, C55-58	220 185	Ceramic capacitor	270 pF 400V	8
C63-C68	220 344	Ceramic capacitor	0,022 F 63V	6
C6-C18, C23-C27, C53, C59-C62	220 498	Ceramic capacitor	100 nF 63V	23
C33, 34, 35, 51	220 142	KT-type capacitor	1000 pF 100V	4
C29-32, 36, 54	220 401	KT-type capacitor	3300 pF 63V	6
C69, 70	220 435	KT-type capacitor	4700 pF 63V	2
C22, 37, 49, 50,	220 334	MKT-type capacitor	0,1 $\mu$ F 63V	4
C42	220 332	MKT-type capacitor	0,33 $\mu$ F 63V	1
<b>Resistors:</b>				
R85-88	221 626	Resistor	1 $\Omega$ 0,34W	4
R64	221 600	Resistor	100 $\Omega$ 0,34W	1
R65, 71	221 614	Resistor	330 $\Omega$ 0,34W	2
R25-28	221 099	Resistor	470 $\Omega$ 0,34W	4
R66, 79-82, 91	221 029	Resistor	1 K $\Omega$ 0,34W	6
R57, 60-62	221 033	Resistor	3,3 K $\Omega$ 0,34W	4
R7-10, R18, 34, 78	221 034	Resistor	4,7 K $\Omega$ 0,34W	7
R15-17, R20-22, 72	221 035	Resistor	10 K $\Omega$ 0,34W	7
R59, 63	221 036	Resistor	15 K $\Omega$ 0,34W	2
R29-33, 35-56, R58, 68, 73-77	221 604	Resistor	22 K $\Omega$ 0,34W	34
R83, 84	221 601	Resistor	27 K $\Omega$ 0,34W	2
R1-6, 67	221 038	Resistor	47 K $\Omega$ 0,34W	7
R23	221 009	Resistor	1 M $\Omega$ 0,34W	1
R11-14, 19	231 527	Met-Resistor, highly flameable	4,7 $\Omega$ 0,34W	5
R24	221 152	Resistor	330 $\Omega$ 0,5W	1
R89, 90	231 139	Metox-Resistor	1,2 $\Omega$ 0,5W	2
R69, 70	221 169	Wire-resistor	10 $\Omega$ 1W	2

Pos.	Part-No.	Description	Data	Quantity
	179 192	CB OPTO, complete		1
ST1	235 074	Sleeve	AMP Micro-Match 8 pin	1
GK1-5	231 322	Opto coupler	LTH-301A-N	5
R1	221 638	Resistor	270 $\Omega$ 0,34W	1
R2	221 624	Resistor	220 $\Omega$ 0,34W	1

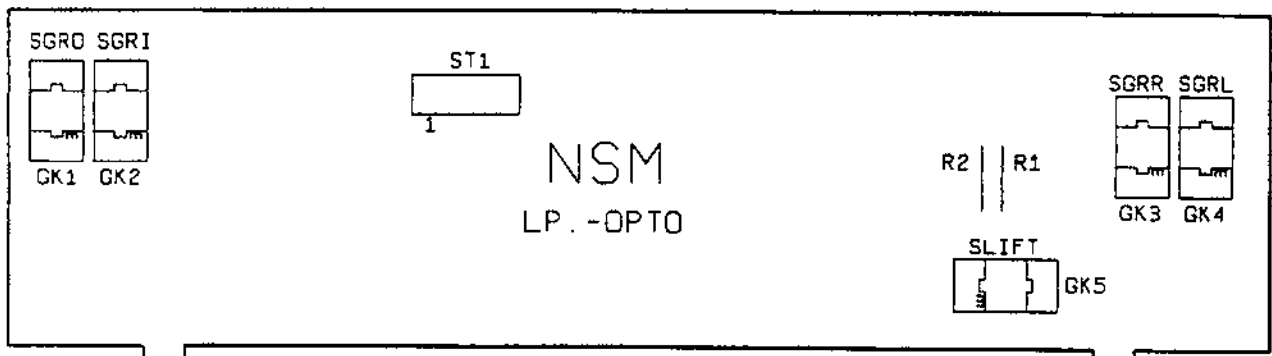

## 6. Wiring diagrams and board layouts

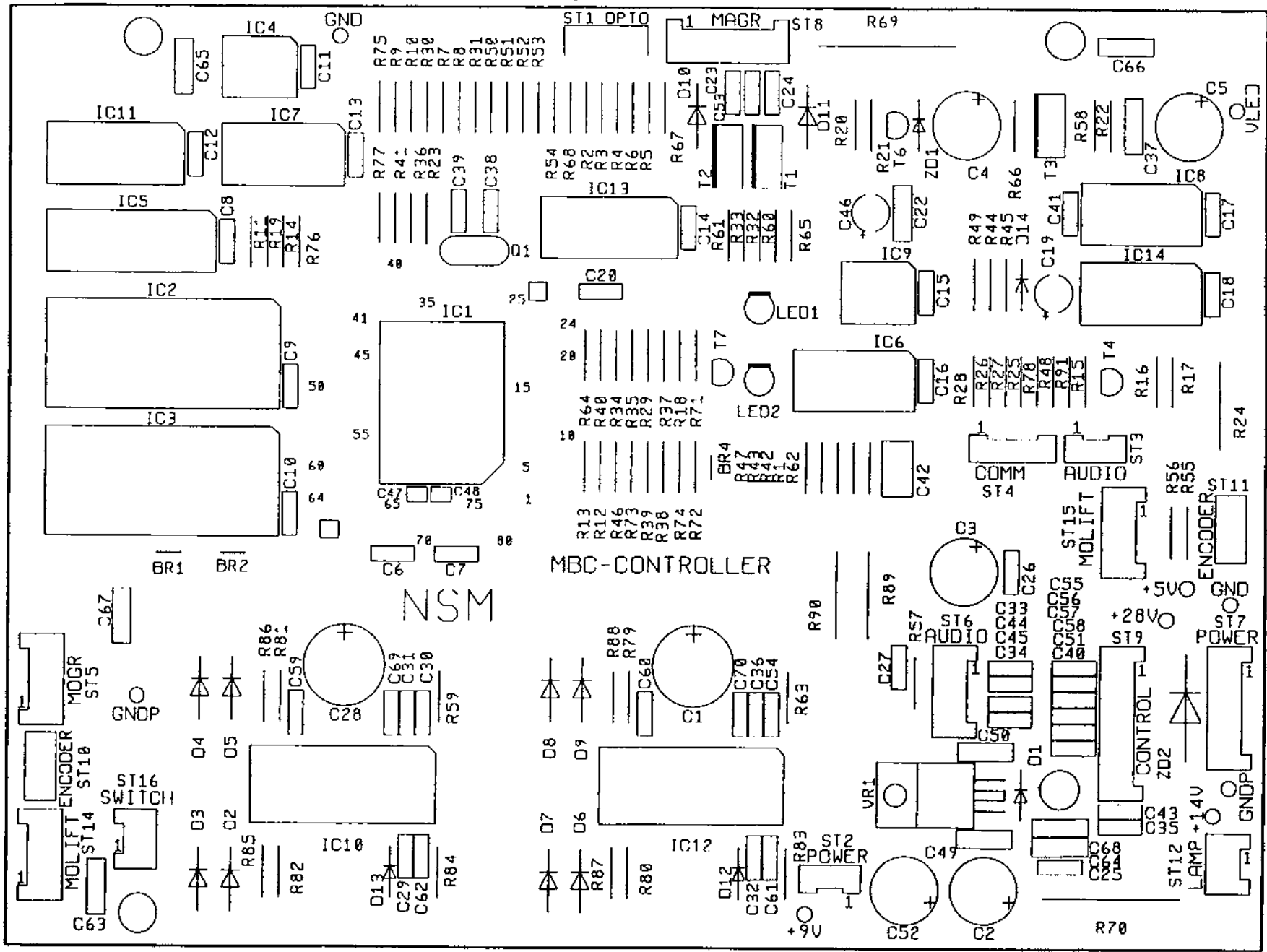

Bestückungsplan / Board layout of the CB MBC-CONTROLLER

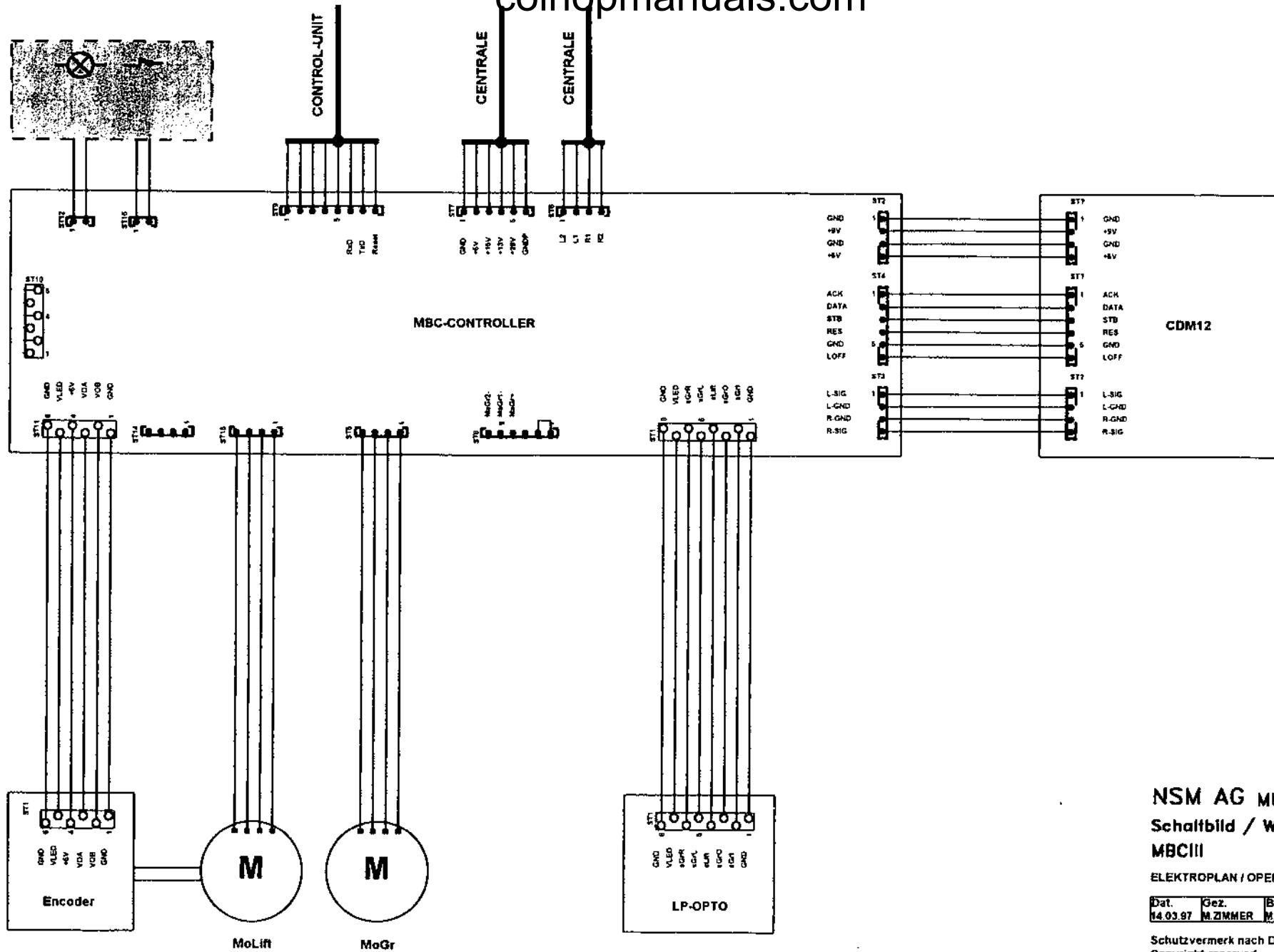

**NSM AG MUSIC**  
**Schaltbild / Wiring diagram**  
**MBCIII**

ELEKTROPLAN / OPERATING SCHEME

Dat.	Gez.	Bearb.	Gepr.
14.03.97	M.ZIMMER	M.ZIMMER	

Schutzvermerk nach DIN34 beachten  
 Copyright reserved

BL 1 VON 5 SHEET 1 OF 5

**Sachnummer: 179126**

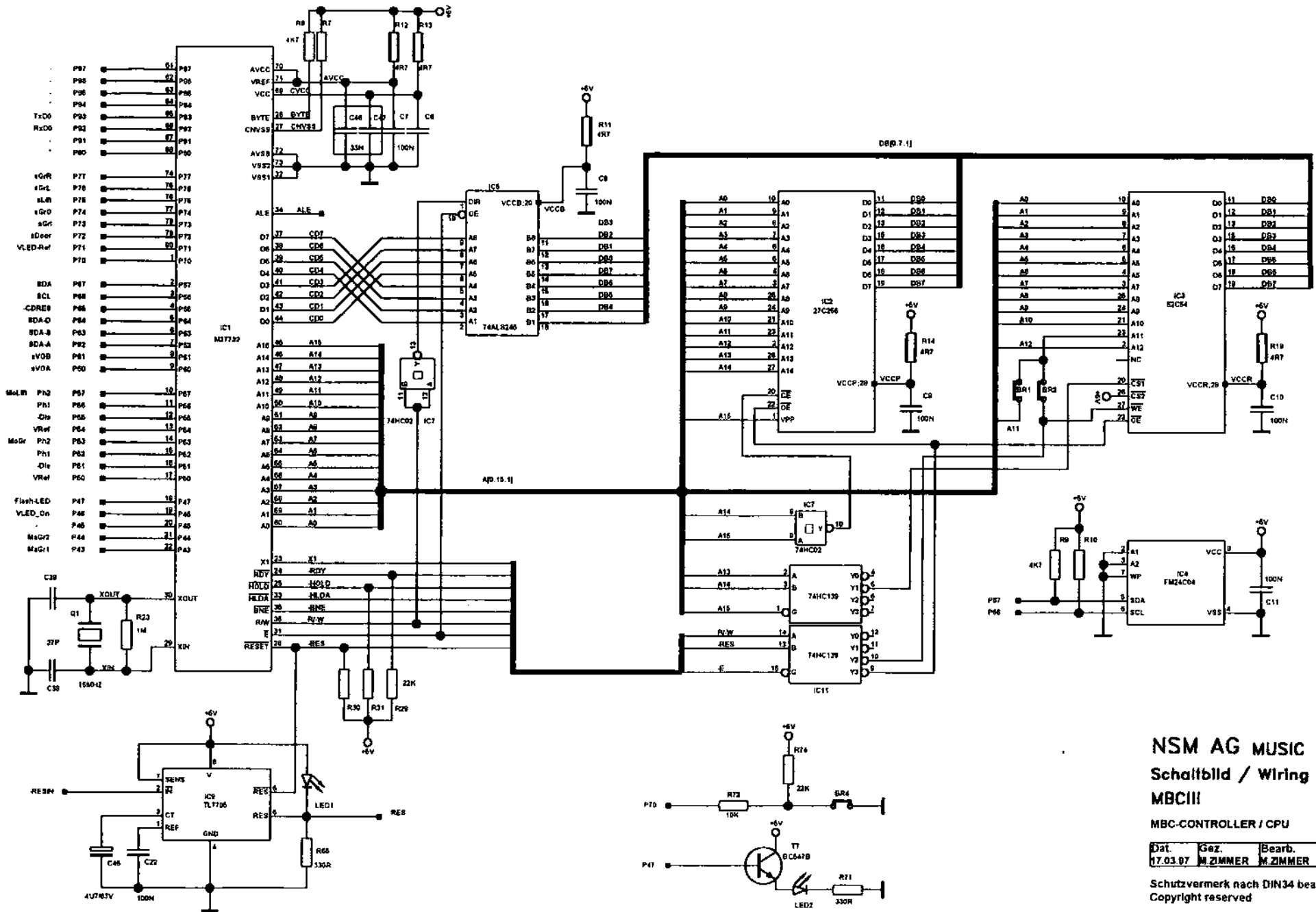

**NSM AG MUSIC**  
**Schaltbild / Wiring diagram**  
**MBCIII**

MBC-CONTROLLER / CPU

Dat.	Gez.	Bearb.	Gepr.
17.03.97	M.ZIMMER	M.ZIMMER	

Schutzvermerk nach DIN34 beachten  
 Copyright reserved

BLATT 2 VON 5 SHEET 2 OF 5

Sachnummer: 179126



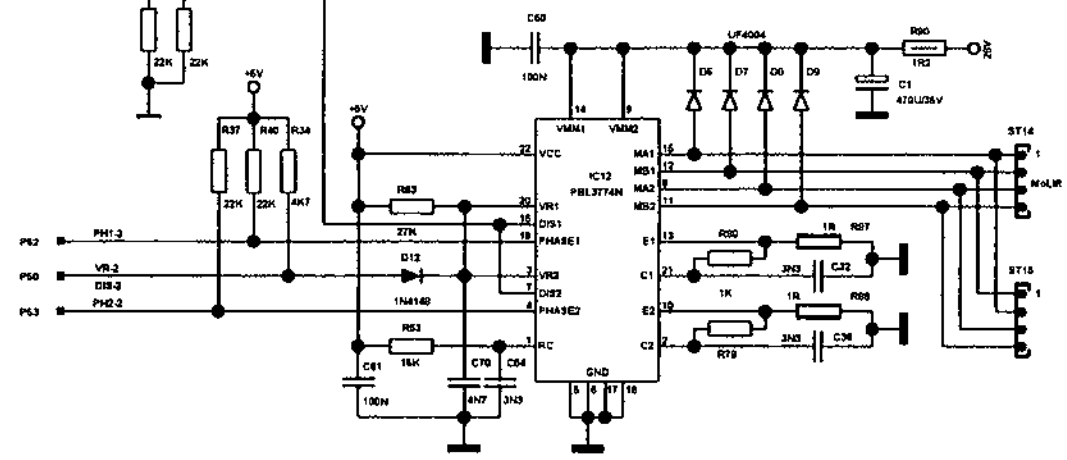
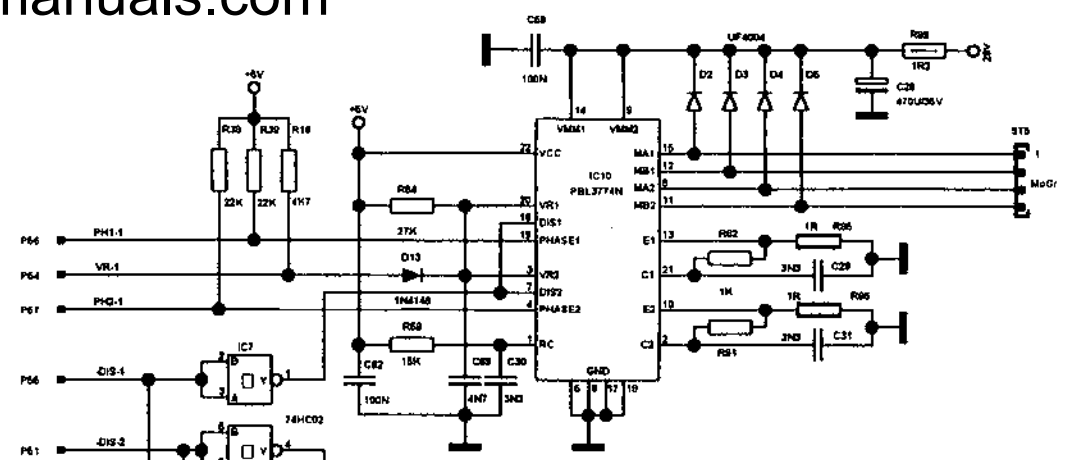
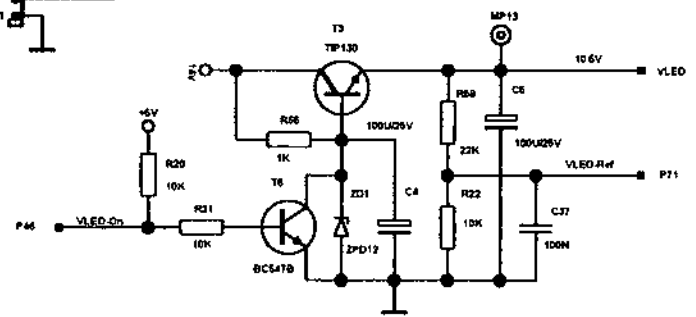
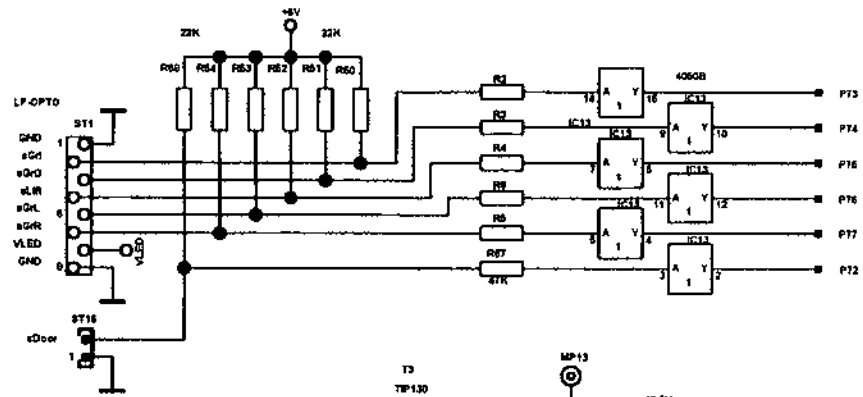
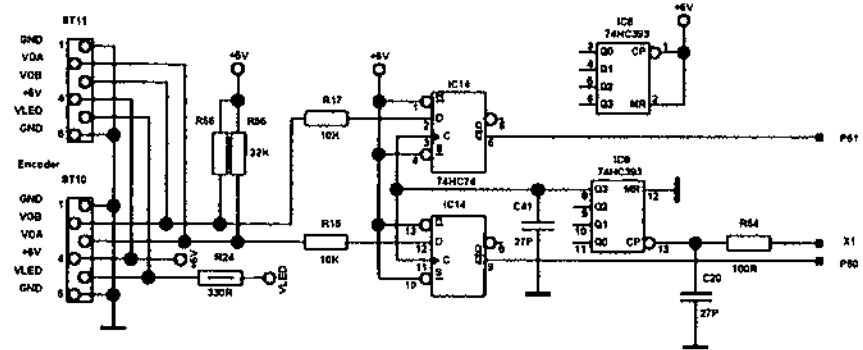
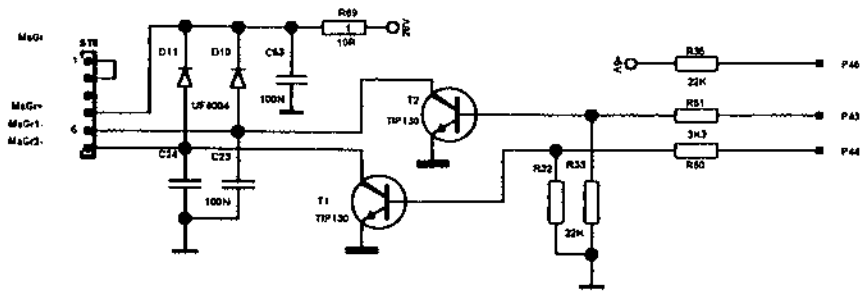

**NSM AG MUSIC**  
**Schaltbild / Wiring diagram**  
**MBCIII**

MBC-CONTROLLER / I/O

Dat.	Gez.	Bearb.	Gepr.
17.03.97	M.ZIMMER	M.ZIMMER	

Schutzvermerk nach DIN34 beachten  
 Copyright reserved

BLATT 3 VON 5 SHEET 3 OF 5

Sachnummer: 179126

Anderungen im Sinne des technischen Fortschrittes vorbehalten, jedoch keine Nachruestpflicht!  
 Subject to technical modification without obligation to modify equipment already delivered!

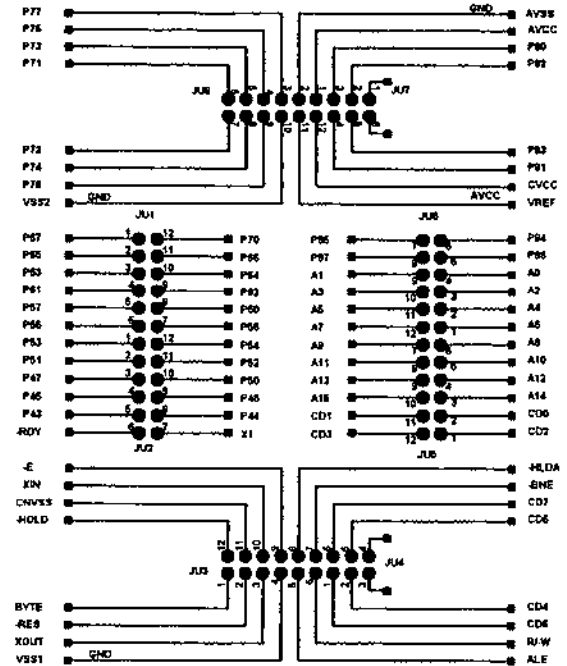
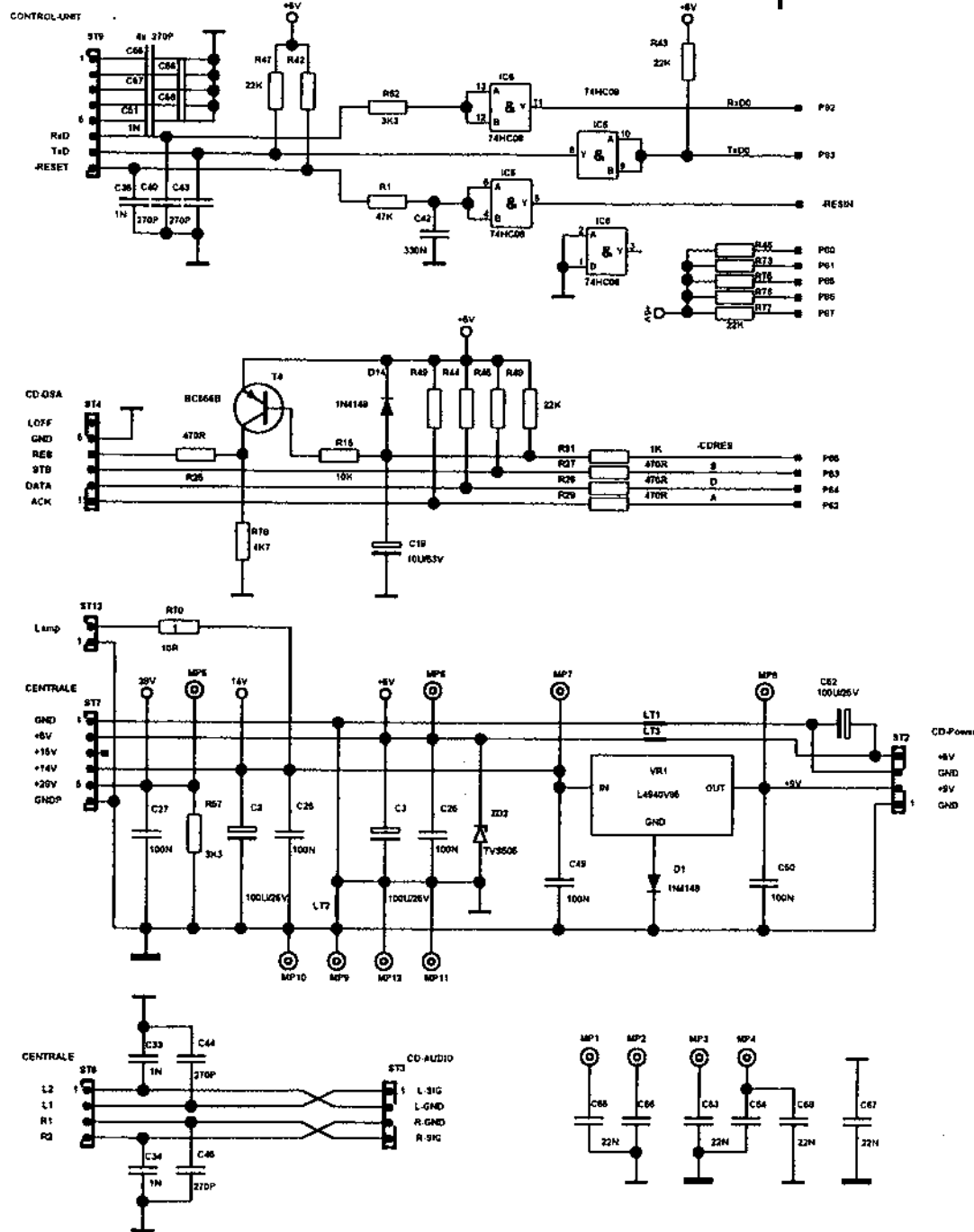

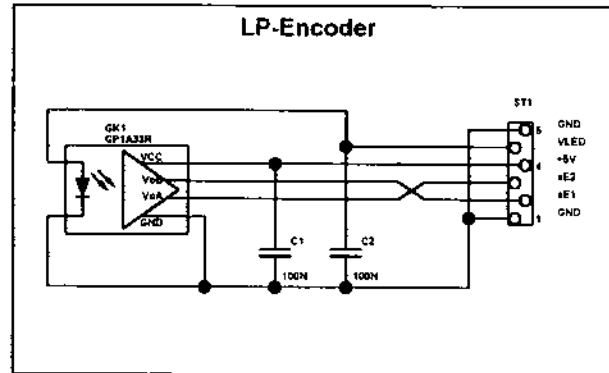
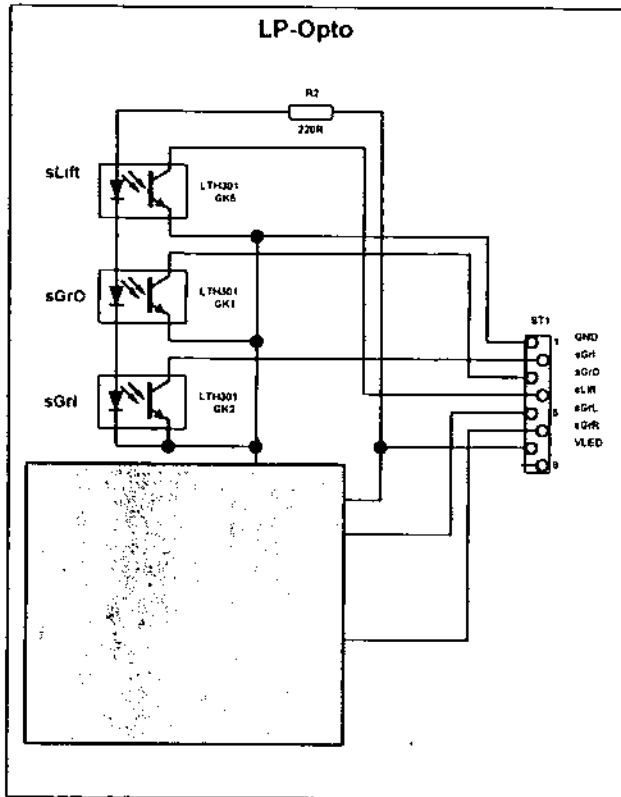

**NSM AG MUSIC**  
**Schaltbild / Wiring diagram**  
**MBCIII**

**SENSORS**

Dat.	Gez.	Bearb.	Gepr.
17.03.97	M.ZIMMER	M.ZIMMER	

Schutzvermerk nach DIN34 beachten  
 Copyright reserved

BL 5 VON 5 SHEET 5 OF 5

**Sachnummer: 179126**

**Appendix B**

The following pages contain informations about the optional MIC-Adapter (part-no. 177 488).

## MIC-Adapter (Part-no.: 177 488)

### Connecting additional audio sources

#### Signal path

The input signal of the microphone is connected to ST1 via the microphone amplifier IC1c and the background control IC1a to pin 8 of connector ST1.

The input signal of an additional stereo signal source (e.g. tape recorder) is expected on Cinch sockets IN-L (BU3) and IN-R (BU4) and also connected to ST1.

Via the cable harness the signals are connected from ST1 to the CB CENTRALEINHEIT connector ST9.

An output signal is available at Cinch sockets OUT-L (BU1) and OUT-R (BU2) e.g. to be connected to an auxiliary amplifier.

By pushing the paging switch of the microphone, pin 5 of the MIC socket (BU5) is connected to GND and the microphone is set to be on first priority. Playing CD or tape music is then interrupted.

The additional AF input IN-L resp. IN-R automatically becomes active from a signal level of 3mV, if no CD is playing and the paging switch of the microphone is not actuated.

The recognition logic is built with IC1b and IC1d.

For the location of the different connectors see also the overleaf figure.

#### Microphone connection

A dynamic microphone with an impedance of  $200\Omega - 600\Omega$  with switch for relay control can be used.

Use potentiometer **POT 2** to set the required microphone volume. This adjustment is dependent upon the position of the microphone in relation to the phonograph. In case of feedback while paging, the microphone volume must be reduced or the microphone must be positioned in another direction to the loudspeakers.

Use potentiometer **POT 1** to set the music volume level during paging (Microphone-Background).

As NSM-accessories are available:

Microphone Order-no.: 224 223

Connection cable, length 10m Order-no.: 171 880

#### Tape recorder connection

Via the Cinch-sockets you may connect a tape recorder for recording music from the phonograph (OUT-L, OUT-R), as well as playing music from the tape (IN-L, IN-R).

The AF signal (500mV at  $10k\Omega$ ) to be recorded to a tape is on sockets BU1 and BU2. It can be fed directly with a stereo diode cable.

The AF signal of a tape to be played has to be fed to sockets BU3 and BU4 (200mV at  $10k\Omega$ ).

#### Connecting auxiliary amplifier

An auxiliary amplifier can be connected to sockets BU1 and BU2. The input sensitivity of this auxiliary amplifier should be 1V at a minimum input impedance of  $10k\Omega$ .

Component side of CB MIC-ADAPTER

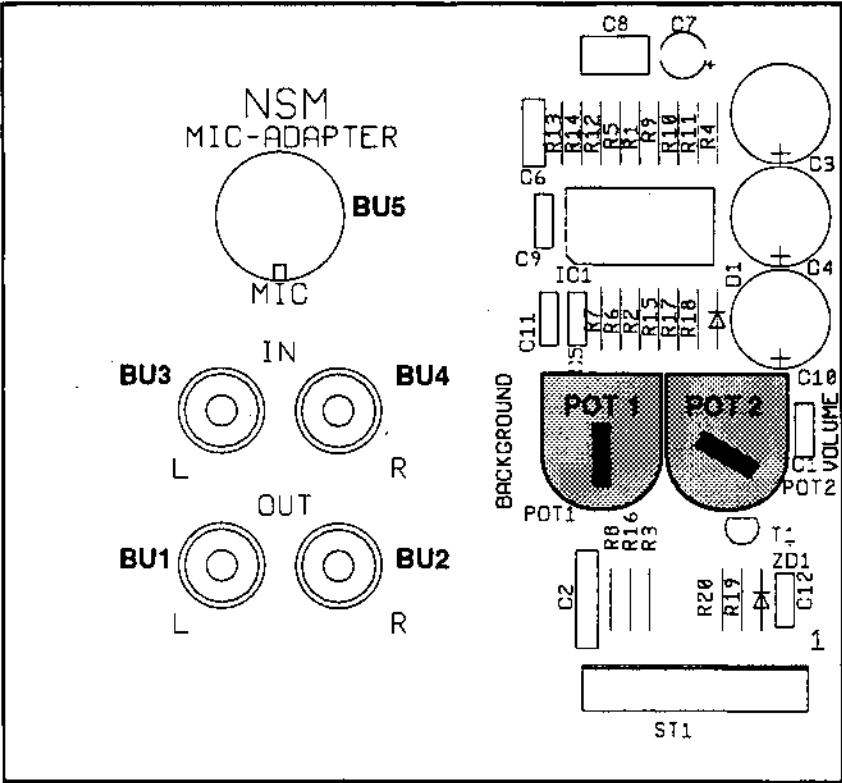

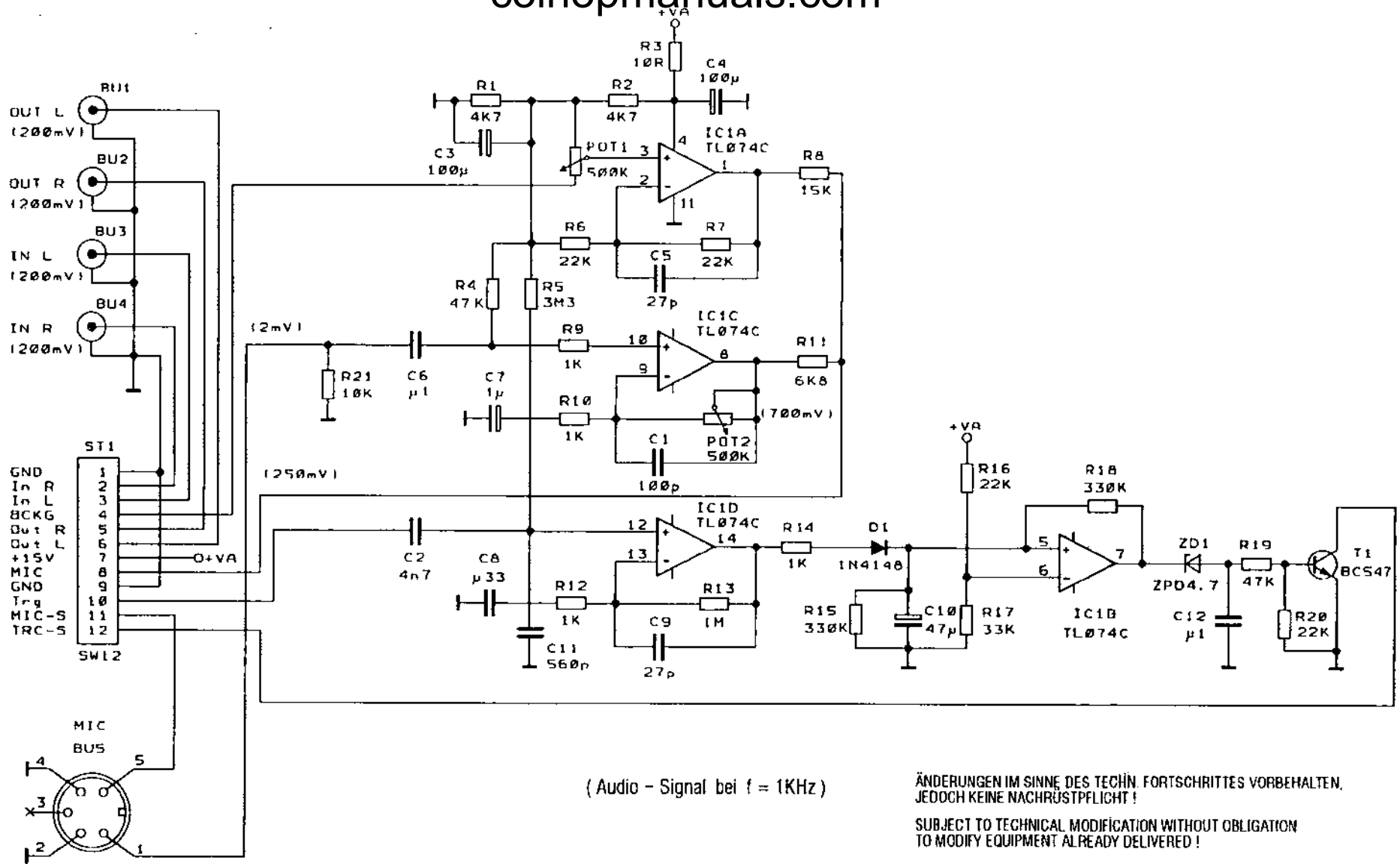

( Audio - Signal bei f = 1KHz )

ÄNDERUNGEN IM SINNE DES TECHN. FORTSCHRITTES VORBEHALTEN, JEDOCH KEINE NACHRÜSTPFLICHT !

SUBJECT TO TECHNICAL MODIFICATION WITHOUT OBLIGATION TO MODIFY EQUIPMENT ALREADY DELIVERED !

Schaltbild  
Wiring diagram MIC-ADAPTER

02.06.98	Braun	Wes.	Wes.
----------	-------	------	------