

## Section 3: Routine Service

### INTRODUCTION

Routine and preventive maintenance are to be performed on your normal periodic service call. This section discusses how to change discs and titles, how to collect money, audit statistics, and preventive maintenance procedures.

### LIFTING THE TITLE RACK



#### CAUTION:

Do not attempt to turn the CD title pages by hand. Use the handwheel on the back of the title rack (see figure 1-2).

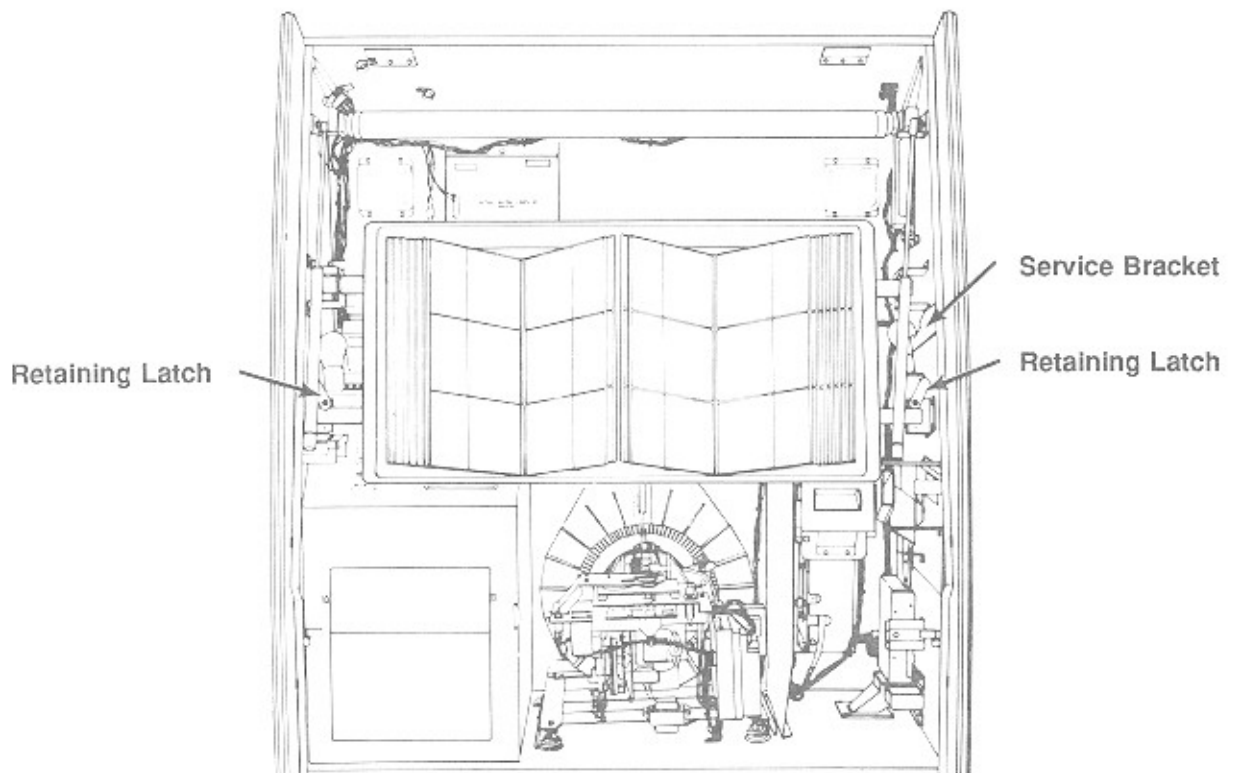

Figure 3-1. Lifting The Title Rack

Before you begin changing discs, you may wish to lift the title rack to give yourself more room to work. Lift the title rack as follows:

1. Open the phonograph top door.
2. Rotate the two retaining latches (see figure 3-1) away from the title rack bar and lift the bottom of the title rack up and toward you with your left hand.
3. With your right hand, swing the title rack service bracket out to hold the title rack up.

## DOING AN AUDIT

The following pages describe how to:

1. Access the phonograph's audit menus and extract audit figures
2. Change title strips and discs
3. Collect money

You can perform these three activities in any order that you wish.

## COLLECTING AUDIT FIGURES

The pages that follow describe the major auditing activities that need to be done on a routine service call. If you wish to do additional auditing, you can obtain the additional commands from table 3-1, the AUDIT commands.

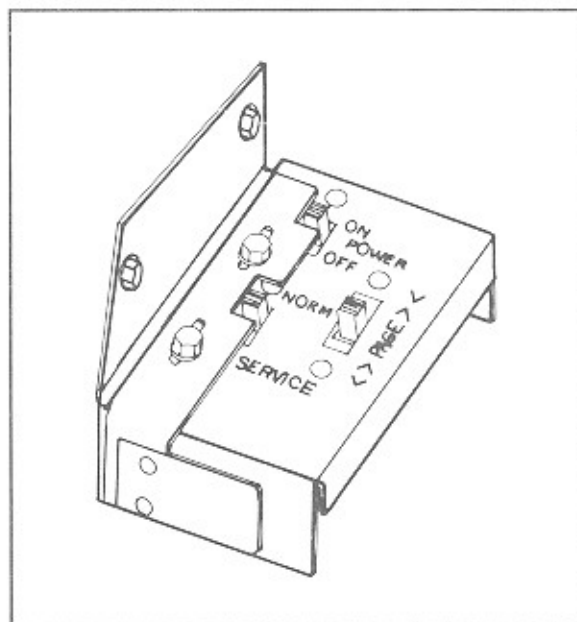

Figure 3-2. Service Switch

## Entering The Service Mode

1. Open the top door and place the SERVICE switch (figure 3-2) in the SERVICE position. The phonograph display will say \* SERVICE MODE \*.



### NOTE:

If you find that you are not seeing the display that you expect, you can always: press and hold RESET and then press POPULAR three times. This will take you back to the main menu.

At this point you can begin doing the audits. Refer to the CD-100B Service Mode Map (figure 2-7) for a diagram of the audit menus and commands. Do audits for cash, play, non-resettables, clear disc popularity, clear cash, clear plays in the following manner:

## Cash Audits

1. Type 100. This displays the CURRENT CASH value. Record the CURRENT CASH figure in your usual way and go to the next step.
2. Press and hold RESET and then press 1. This will move you down to the next display. Record the CASH VALUE in the usual way.
3. Repeat Step 2 until you do the last CASH audit, which is the #2 BILLS audit. Do this audit and then press and hold RESET while you press POPULAR three times.

## Play Audits

1. Type 110. This displays the FREE CREDITS value. Record the FREE CREDITS figure in your usual way and go to the next step.
2. Press and hold RESET and then press 1. This will move you down to the next display. Record the credit value in the usual way.
3. Repeat Step 2 until you do the last PLAY audit, which is the OVERPLAY audit. Do this audit and then press and hold RESET while you press POPULAR three times.

## Non-Resettable Audits

1. Type 120. This displays the NON-RESETTABLE CASH value. Record the NON-RESETTABLE CASH value in your usual way and go to the next step.
2. Press and hold RESET and then press 1. This will move you down to the next display. Record the value in the usual way.
3. Repeat Step 2 until you do the last NON-RESETTABLE audit, which is the SELS audit. Do this audit and then press and hold RESET while you press POPULAR three times. This returns you to the main menu.

## Most Popular Disc

1. Type 17. The most popular disc number will be displayed.
2. If you wish to know the next-to-the-most popular, press and hold RESET and then press 3. Press and hold RESET and then press 3 to display each successive "Most Popular" disc. Press and hold RESET and then press 2 to move through the popularity display toward the most popular disc.
3. Press and hold RESET while you press POPULAR twice. This returns you to the main menu.

## Least Popular Disc

1. Type 18. The least popular disc will be displayed.
2. To display the next "Least Popular" disc, press and hold RESET and then press 2. Press and hold RESET and then press 2 to display each successive least popular disc. Press and hold RESET and then press 3 to move through the popularity display toward the least popular disc.
3. Press and hold RESET while you press POPULAR twice. This returns you to the main menu.

## Most Popular Selection

1. Type 19. The most popular selection number will be displayed.
2. To display the next most popular selection, press and hold RESET and then press 3. Press and hold RESET and then press 3 to display each successive most popular selection. Press and hold RESET and then press 2 to move through the popularity display toward the most popular selection.

You can request the popularity for a particular selection by pressing the selection number (four digits).

## Clearing The Audit Values

The three CLEAR options will not clear the corresponding audit value until the POPULAR button is pressed.

### For example:

You can display the CLEAR CASH message and then move to CLEAR PLAYS and then move back to CLEAR CASH without actually clearing either set of values.

The following steps describe how to perform each of the three CLEAR commands as a separate activity. If you wish to use the "short cut" method, *follow the Using The CD-100B Commands instructions in Section 2*. Each of these commands may be executed from SECURITY LEVEL 2 or 3.

### CLEAR CASH

1. Make sure that you are in the SERVICE mode and that \* SERVICE MODE \* is on the display.
2. Type 14. The message CLEAR CASH will appear on the display. Press POPULAR to clear the cash values. The display will blink when the command is executed.
3. Press and hold RESET while you press POPULAR twice.

### CLEAR PLAYS

1. Make sure that you are in the SERVICE mode and that \* SERVICE MODE \* is on the display.
2. Type 15. The message CLEAR PLAYS will appear on the display. Press POPULAR to clear the play values. The display will blink when the command is executed.
3. Press and hold RESET while you press POPULAR twice.

### CLEAR SELECTION POPULARITY

1. Make sure that you are in the SERVICE mode and that \* SERVICE MODE \* is on the display.
2. Type 16. The message CLEAR SEL POP will appear on the display. Press POPULAR to clear the popularity values. The display will blink when the command is executed.
3. Press and hold RESET while you press POPULAR twice.

## CHANGING CD'S AND TITLES

**NOTE:**

Do not attempt to turn the CD title pages by hand. Use the handwheel on the back of the title rack (see figure 1-2).

The procedure for loading CD's and titles into an empty phonograph is different from the procedure to change CD's and titles. Please make sure that you are following the procedure that describes your situation.

**Preparing Titles For The Title Rack**

1. If your titles have not been shipped with the discs or pre-printed, you will need to prepare the title strips yourself.
2. Tear each title strip from the title sheet so that the two perforated columns appear on the side of the title strip (the shaded portion of the title strip in figure 3-3 represents a title strip that has been removed from the title sheet).

Separate Here

Separate Here

TRACK NO NO. 1 2 DIGITS	DISC NO. FIRST 2 DIGITS	TRACK NO NO. 1 2 DIGITS	DISC NO. FIRST 2 DIGITS
01		01	
02		02	
03		03	
04		04	
05		05	
06		06	
07		07	
08		08	
09		09	
10		10	
11		11	
12		12	
13		13	
14		14	
ARTIST		ARTIST	
01		01	
02		02	
03		03	
04		04	
05		05	
06		06	
07		07	
08		08	
09		09	
10		10	
11		11	
12		12	
13		13	
14		14	
ARTIST		ARTIST	

Separate Here

BLANK TITLE STRIP      COMPACT DISC

**ROWE - MI CD-100**      109.15.90.3

Discard

Figure 3-3. Blank Title Sheet

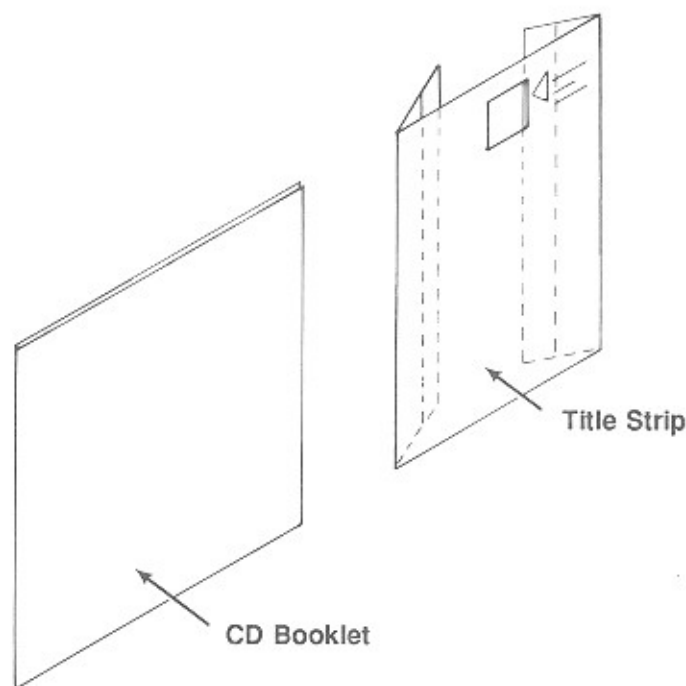

Figure 3-4. Folding The Title Strip

3. Fold the title strip along the inner most perforated line on both sides of the title strip (see figure 3-4).
4. Locate the CD album booklet that matches the title strip that you have just made. If the CD booklet is more than two sheets thick, remove the inner sheets so that the booklet is no thicker than two title strips.
5. Insert the CD booklet under the top and bottom tabs of the title rack. Slide the CD booklet toward the pivot of the title rack until the booklet is trapped by the molded stops on the title page (see figure 3-5, ref A).
6. Insert the folded title strip under the top and bottom tabs of the title rack. Slide the title strip until the disc number shows in the opening of the title strip and the title strip is locked in place by the molded stops (see figure 3-5, ref B).
7. All of the tabs surrounding the CD booklet and title strip should be holding them in place. If you missed a tab, carefully tuck the loose paper under the tab as shown in figure 3-5, ref C.
8. Repeat steps 4 through 7 until all titles are installed. Use the CHANGE PAGE buttons to change title rack pages. Insert filler title strips (Part Number 30940601) to fill out any unused space left on a page. Insert these in the same way that you installed the fill-in title strips.

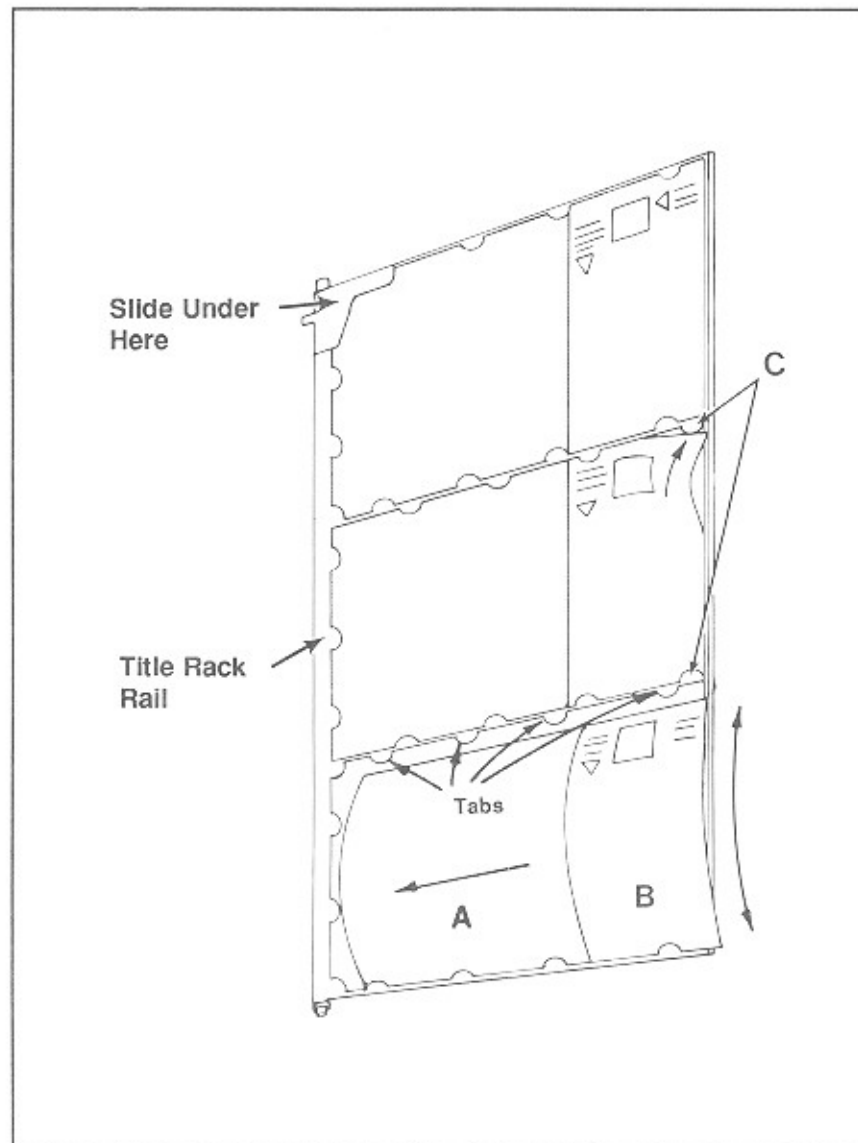

Figure 3-5. Loading the Title Rack  
(Right-Hand Page)

### Changing Title Page Limits On An Installed Phonograph

1. Unlock and open the top door, if you have not already.
2. Move the SERVICE switch to the SERVICE position, if not already done (*refer to figure 3-2*).
3. Make sure that \* SERVICE MODE \* appears on the display.
4. Type 24 and you will see the display for entering the first page number to use and the last number to use. Type the first page number (page numbers are counted from the left to the right) and press POPULAR. Notice that the blinking number has moved to the right. Type the last page number to be used and press POPULAR.

## Changing Discs

You can (1) initialize each disc as you change it, or (2) you can write down all of the disc numbers and then type them all into the INITIALIZE command. The following steps describes the second method.

Change discs as follows:

1. Unlock and open the top door, if not already done.
2. Move the SERVICE switch to the SERVICE position, if not already done (refer to figure 3-2).
3. Press the SCAN button to move the disc space to the left or right of the transfer arm.
4. Slide the old CD out of the slot and slide the new CD into the slot (see figure 3-6) with the label to the right. Write the disc number on a note pad.

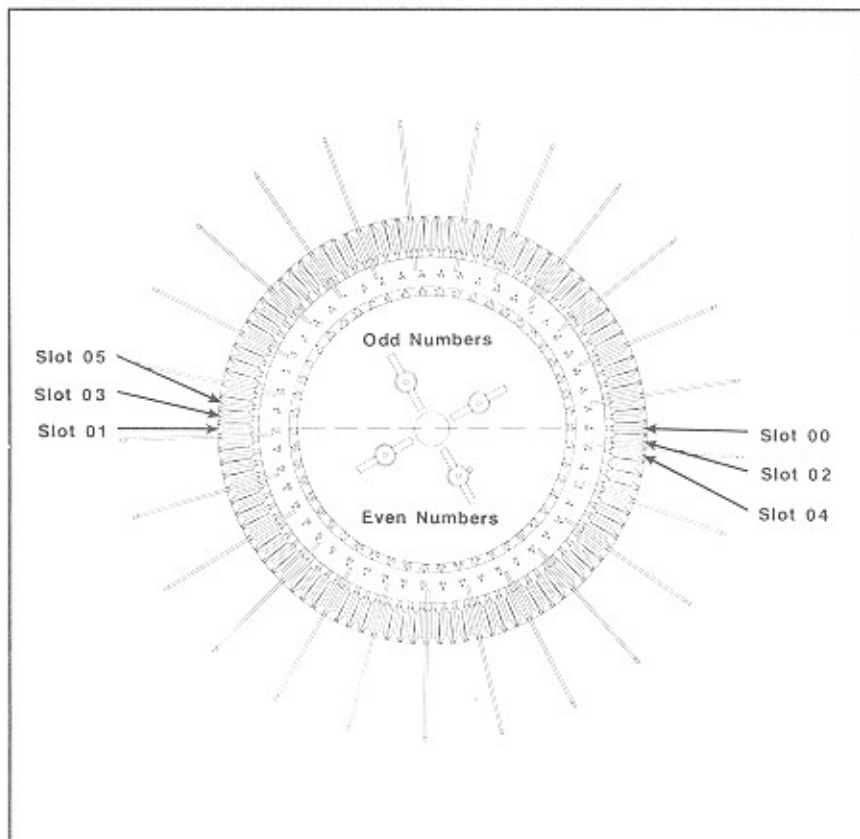

Figure 3-6. Loading The Molded CD Magazine

Note that disc positions in the molded CD magazine are identified by numbers at every other slot, with even numbered slots labeled on one half of the magazine, and odd numbered slots labeled on the other half.

For example, on the even numbered half of the magazine, slots 00, 04, and 08 are labeled, and the slots in between - 02 and 06 - are not, as illustrated in figure 3-6.



### NOTE:

When loading the magazine, be sure that the disc rests in the same numbered slot in both the front and rear of the magazine.

Be sure to keep the magazine disc load approximately balanced. If the magazine is partially loaded with all discs on one side, The sprag wheel may lock and the magazine will not turn.

5. Repeat step 4 until all discs have been changed.
6. Make sure that you have placed the SERVICE switch in the SERVICE mode and that \* SERVICE MODE \* is on the keyboard display.
7. Type 31 and the display will show PROGRAM INIT - -. Enter the CD numbers that you have changed and press POPULAR after each number. After you have entered all of the disc numbers, place the phonograph into the NORMAL mode and the initialization process will start. Selections can be made while the new discs are being initialized.



## COMPLETE AUDIT COMMAND LIST

Table 3-1 is a complete list of the Audit commands with an explanation of what each command does.

Table 3-1. Audit Commands

Command	Description
1	<b>AUDITS</b> - Are the functions and menus that allow you to display and reset the various accumulated figures for money, popularity, number of plays, and credits.
10	<b>Cash Audits</b> - Is the menu that allows you to display, but not change, cash totals, number of coins through the coin switches, and the total number of bills.
11	<b>Play Audits</b> - Is the menu that allows you to display, but not change, credits, autoplays, mechanism plays, and album plays.
12	<b>Non-Resettables</b> - Is the menu that allows you to display the ongoing totals. These totals cannot be reset from any security level.
13	<b>Clear Disc Popularity</b> - Clears the popularity for all discs. This option should only be used after the popularity figures (Selections 7 and 8 in this menu) have been read and recorded. Press POPULAR to clear the disc popularity values. The display will blink when the command is executed.
14	<b>Clear Cash</b> - Clears all current cash totals. This option should only be used after the figures for Cash Audits (Selection 0 in this menu) have been read and recorded. Press POPULAR to perform this function. The display will blink when the command is executed.
15	<b>Clear Plays</b> - Clears all current play totals. This option should only be used after the Play Audit figures in Play Audits (Selection 1 in this menu) have been read and recorded. Press POPULAR to perform this function. The display will blink when the command is executed.
16	<b>Clear Selection Popularity</b> - Clears all current selection popularity. This option should only be used after Popularity Figures (Selection 9 in this menu) have been read and recorded. Press POPULAR to perform this function. The display will blink when the command is executed.
17	<b>Display The Most Popular Disc</b> - Displays the most popular disc number (00-99), followed by the number of plays (9999 maximum) that disc had. To display the next most popular disc, press and hold RESET and then press 3. Press and hold RESET and then press 3 to display each successive most popular disc. Press and hold RESET and then press 2 to move up through the popularity display toward the most popular disc.

You can request the popularity for a particular disc by pressing the disc number.

Table 3-1. Audit Commands  
Continued

Command	Description
18	<p><b>Display The Least Popular Disc</b> - Displays the least popular disc number (00-99) followed by the number of plays that the disc had. To display the next "least popular" disc, press and hold RESET and then press 2. Press and hold RESET and then press 2 to display each successive least popular disc. Press and hold RESET and then press 3 to move up through the popularity display toward the least popular disc.</p> <p>You can request the popularity for a particular disc by pressing the disc number.</p>
19	<p><b>Display The Most Popular Selection</b> - Displays the most popular selection number (Disc 00-99 followed by Selection 00-99, a total of four digits), followed by the number of plays (9999 maximum) that selection had. To display the next "Most Popular" selection, press and hold RESET and then press 3. Press and hold RESET and then press 3 to display each successive most popular selection. Press and hold RESET and then press 2 to move up through the popularity display toward the most popular selection. A total of 100 selection numbers may be contained in the MOST POPULAR list.</p> <p>You can request the popularity for a particular selection by pressing the selection number (four digits).</p>
10	<p><b>CASH AUDITS</b> - Allows you to display, but not change, cash totals, number of coins through the coin switches, and the total number of bills.</p>
100	<p><b>Current Cash</b> - Displays the total amount of bill and coin money collected since the last time the CLEAR CASH command (Selection 4 in the AUDITS menu) was used.</p>
101	<p><b>Current Bill</b> - Displays the total amount of bills collected since the last time the CLEAR CASH command (Selection 4 in the AUDITS menu) was used.</p>
102	<p><b>Current Coin</b> - Displays the total amount of coins collected since the last time the CLEAR CASH command (Selection 4 in the AUDITS menu) was used.</p>
103	<p><b>Current Wallbox</b> - Displays the total amount of money collected by wallboxes since the last time the CLEAR CASH command (Selection 4 in the AUDITS menu) was used.</p>
104	<p><b>Current Number Of Type 1 Coins</b> - Displays the total number of Type 1 coins (5¢) collected since the last time the CLEAR CASH command (Selection 4 in the AUDITS menu) was used.</p>
105	<p><b>Current Number Of Type 2 Coins</b> - Displays the total number of Type 2 coins (10¢) collected since the last time the CLEAR CASH command (Selection 4 in the AUDITS menu) was used.</p>
106	<p><b>Current number Of Type 3 Coins</b> - Displays the total number of Type 3 coins (25¢) collected since the last time the CLEAR CASH command (Selection 4 in the AUDITS menu) was used.</p>

**Table 3-1. Audit Commands**  
*Continued*

Command	Description
107	<b>Current Number Of Type 4 Coins</b> - Displays the total number of Type 4 coins (50¢) collected since the last time the CLEAR CASH command (Selection 4 in the AUDITS menu) was used.
108	<b>Number Of Type 1 Bills</b> - Displays the total number of Type 1 (\$1) bills collected since the last time the CLEAR CASH command (Selection 4 in the AUDITS menu) was used.
109	<b>Number Of Type 2 Bills</b> - Displays the total number of Type 2 (\$5) bills collected since the last time the CLEAR CASH command (Selection 4 in the AUDITS menu) was used.
11	<b>PLAY AUDITS</b> - Allows you to display, but not change, credits, autoplays, mechanism plays, and album plays.
110	<b>Free Credits</b> - Displays the number of free credits given since the last time the CLEAR PLAYS command (Selection 5 in the AUDITS menu) was used.
111	<b>Paid Credits</b> - Displays the number of paid credits given since the last time the CLEAR PLAYS command (Selection 5 in the AUDITS menu) was used.
112	<b>Autoplays</b> - Displays the number of Autoplays made since the last time the CLEAR PLAYS command (Selection 5 in the AUDITS menu) was used.
113	<b>Mechanism Plays</b> - Displays the number of times the mechanism has played CD's since the last time the CLEAR PLAYS command (Selection 5 in the AUDITS menu) was used.
114	<b>Album Buys</b> - Displays the number of times albums have been bought since the last time the CLEAR PLAYS command (Selection 5 in the AUDITS menu) was used.
115	<b>Most Popular plays</b> - Displays the number of times that the POPULAR button was used to select the most popular selection since the last time the CLEAR PLAYS command (selection 5 in the AUDITS menu) was used.
116	<b>Normal Selections</b> - Displays the number of selections made from the keyboard.
117	<b>Overplay</b> - Displays the number of overplays selected since the last time the CLEAR PLAYS command (Selection 5 in the AUDITS menu) was used.
12	<b>NON-RESETTABLES</b> - These totals for cash, plays, and credits can be displayed from any security level, but they cannot be reset from any security level. These totals constitute the permanent phonograph history.
120	<b>Cash</b> - Displays total cash (bill and coin) received by the phonograph.
121	<b>Bill</b> - Displays total bill cash received by the bill acceptor.

**Table 3-1. Audit Commands**  
*Continued*

<b>Command</b>	<b>Description</b>
122	<b>Coin</b> - Displays total coin cash received by the coin acceptor.
123	<b>Wallbox</b> - Displays total cash received by all wallboxes.
124	<b>Free</b> - Displays total free credits
125	<b>Paid</b> - Displays total paid for credits
126	<b>Most Popular</b> - Displays the total number of Most Popular selections made with the POPULAR button.
127	<b>Mechanism</b> - Displays the total number of mechanism cycles.
128	<b>Album</b> - Display total album buys.
129	<b>Selections</b> - Displays the total number of selections made using the keyboard.

## Collecting Money

1. Open the top door (if it is not already open) and reach in, behind the bill acceptor, and unlock the bill acceptor bill box.
2. Remove the currency and close and lock the bill box.
3. Close the top door.

## PREVENTIVE MAINTENANCE

Preventive maintenance should be performed at the regular intervals specified, while adjustments should be made only when necessary.

In addition to cleaning the cabinet each time the location is visited, clean the interior every three to six months, as required. Keeping the cabinet interior clean reduces dust, resulting in increased disc and component life (see table 3-2 for details).

- Use a vacuum cleaner to remove heavy dust deposits.
- Use a clean, lint free cloth saturated in denatured alcohol to clean mechanical parts.
- Clean electrical parts using a clean, dry cloth or camel hair brush.



### WARNING:

Use solvents in a well ventilated area only. Do not use solvents on plastic parts.

Table 3-2. Cabinet Cleaning

Action Required	Procedure
1. Clean Glass	a. Clean all glass with a paper towel and a non-abrasive glass cleaner such as Windex. b. Dry with a clean, lint-free cloth.
2. Clean painted wood and metal surfaces	a. Clean all painted wood and metal surfaces with mild soap and water. <b>DO NOT USE SOLVENTS.</b> b. Apply a good quality auto or furniture wax to protect the finish.
3. Clean chrome trim	a. Use a damp or dry cloth to remove any dust or dirt. b. Use mild soap and water to remove stubborn deposits. Do not use strong detergents or abrasives of any kind.
4. Clean plastic trim	a. Wipe all plastic surfaces with a damp or dry cloth only. <b>DO NOT USE SOLVENTS.</b>
5. Clean electrical components	a. Clean all electrical components with a clean, dry, lint-free cloth or a soft bristled brush only.

## CD Player Laser Lens

The CD player laser lens can collect dust, dirt, and smoke. These deposits can cause various intermittent problems that may, in time, become more severe. To avoid these problems, we recommend that you clean the laser lens occasionally. This interval can be as often as every other month, or less in some locations. Follow this procedure to safely clean the laser lens:



### NOTE:

Before you clean the laser lens, be sure to turn the jukebox power OFF and ground yourself by touching a grounded component (such as the OBA) to discharge any static buildup that may harm the CDM-3 player.

1. Remove loose particles from the lens by gently brushing it with a camel's hair brush or a blow brush (both items can be purchased at most camera supply stores). Take care not to snag brush bristles under the lens. The lens is mounted on a delicate suspension spring that may be damaged with even a soft brush.
2. Remove any remaining dirt by placing one to three drops of Kodak Lens Cleaner (Kodak Catalog Number 176 7136, available from photographic supply stores) on a lint-free "Q"-Tip and very gently wiping dust and smoke deposits from the lens. Take care not to damage the delicate lens suspension spring. Do not allow any of the lens cleaner to run down the side of the lens.

## COIN ACCEPTORS (optional)

### Coin Switch

Coin Switch Wiring Note:

Table 3-3 shows how to set the coin switch values for 3-coin and 4-coin acceptors. Programming The multiplier (PRICING SELECTION 3) should always be set to 5 for U.S. currency.

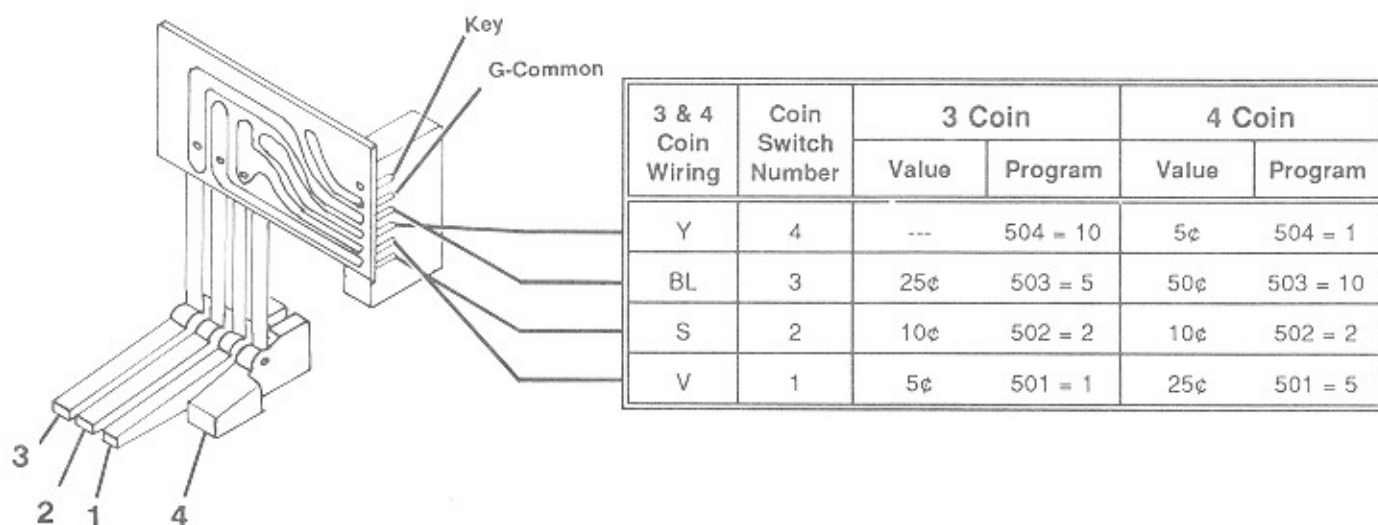
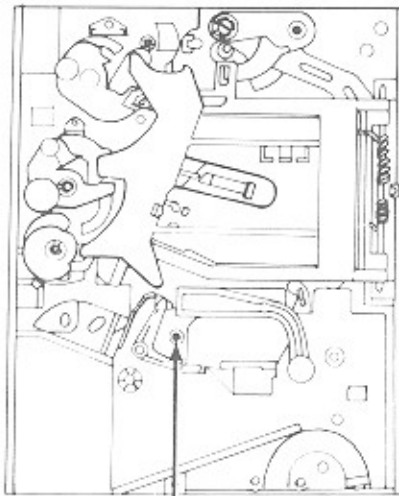
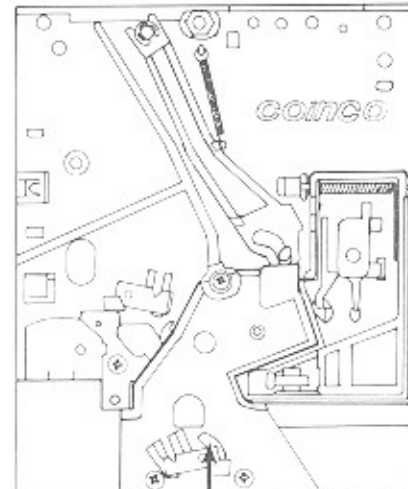

Table 3-3. Coin Switch Wiring

### 3 Coin Acceptor



REMOVE COVER AND DRIVE  
No. 6-32 SCREW INTO BOSS AS  
SHOWN TO REJECT NICKELS



TO REJECT DIMES ADD COINCO  
No. 903-915 BLOCK OUT WIRE

### 4 Coin Acceptor

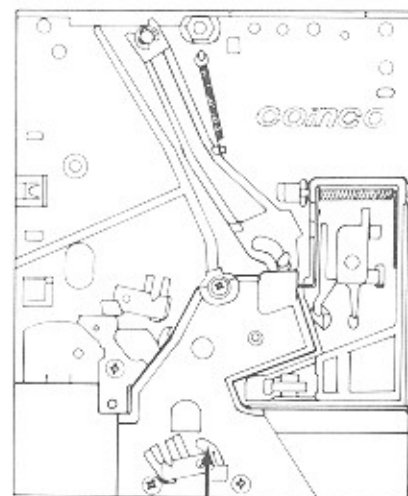
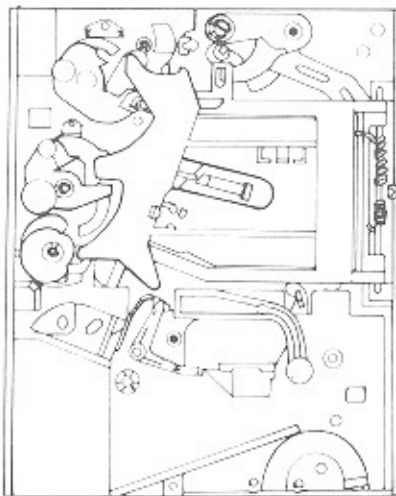

TO REJECT DIMES ADD  
COINCO No. 903-915 BLOCK OUT WIRE

Figure 3-7. Coin Acceptors

## CHECKS AND ADJUSTMENTS

## Coin Lever

Refer to figures 3-7 and 3-8 in the following steps:

1. Hold the plastic coin switch lever in the normal position and drop a coin through the slug rejector.
2. When the coin comes to rest on the lever, release the lever slowly.
3. Check that the weight of the coin operates the lever enough to close the coin switch and allow the coin to fall free.
4. Repeat Steps 1, 2, and 3 for the other three levers.

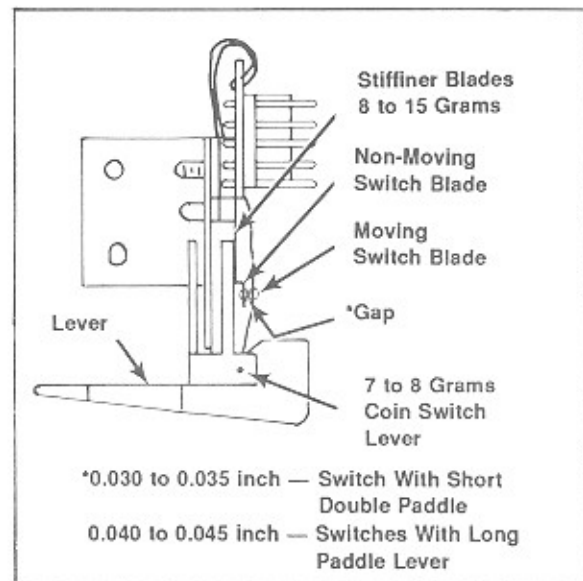

Figure 3-8. Contact Pressure  
& Gap Adjustment

## Contact Pressure And Gap

1. Check that each moving switch blade pushes against its lever with 7 to 8 grams force to hold the lever against the cushion (*see figure 3-8*). To adjust the pressure, bend the blade near its mounting point.
2. Check that each non-moving blade pushes against its stiffener blade with 8 to 15 grams force. To adjust the pressure, bend the contact blade near its mounting point.
3. Check that contact gap at switch with short double paddle is 0.035 inch. Check that the contact gap for long paddle switches is 0.045 inch.



## DOOR SPRING REPLACEMENT

1. Open the top door.
2. While another person keeps the door open, find the appropriate style spring end fitting in *figure 3-9* and follow the example given.

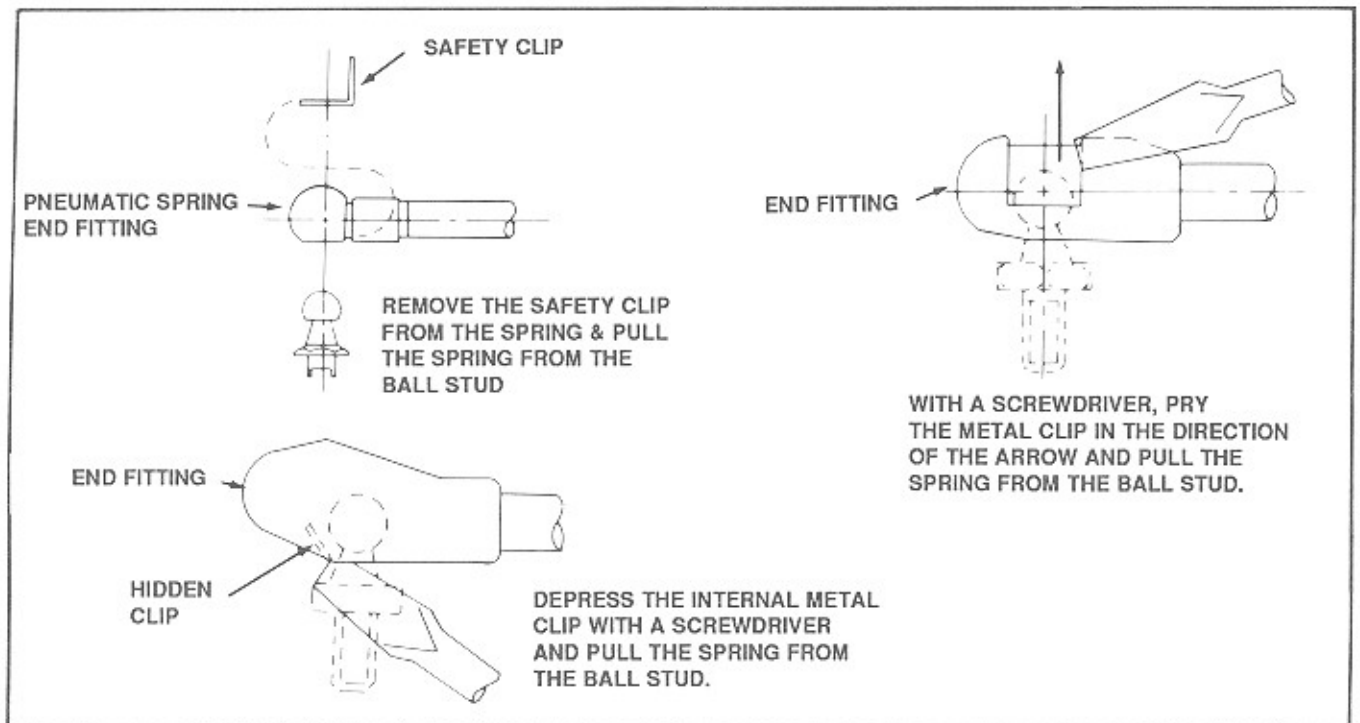

Figure 3-9. Door Spring Fittings

## GLASS REPLACEMENT

**WARNING:**

The top door glass can break or fall on you if you do not follow the recommended removal procedure.

For your safety, Rowe does not recommend that you replace the top door glass while the top door is on the phonograph. The proper procedure requires two people to remove the top door safely.

1. Unplug the power to the phonograph.
2. Open the cabinet door.
3. Unplug the 120 volt AC harness at the connector on the upper right side of the phonograph. Unplug the 3-pin connector from the central control computer and disengage the harness from the cable clamps.
4. Remove all of the top door hinge screws except for one screw and one nut at each end of the hinge.
5. With your helper still holding the top door open, disconnect the door springs (use the *Door Spring* procedure in this section if you are not familiar with the procedure for removing the door springs).
6. Remove the two remaining top door hinge screws while your helper continues to hold the top door open.
7. Again, using a helper, lift the top door off of the phonograph and set the door on a clean smooth working surface (lay the door so the outside is down).
8. Remove all of the shroud bracket screws from the four shroud brackets.
9. Lift out the brackets and the plastic shroud.
10. Be sure to protect your hands from broken glass with protective gloves before you remove the door glass. Remove the remaining glass with any available brush.
11. Set the new door glass in the door, re-install the door shroud, and brackets.
12. Lift the door back onto the phonograph and attach all screws and nuts through the hinge. Make sure that the door is centered before you tighten all of the screws.
13. While your helper holds the door, reconnect the door springs and make sure that the door will be supported by the springs.
14. Reconnect the 120 volt AC harness (on the right side of the phonograph) and the other harnesses on the left side of the phonograph and then push them into the cable clamps.
15. Plug-in the phonograph and play a selection and make sure that the title rack pages turn, all lights are on, and the animated discs turn.
16. Check the top door-to-OBA clearance and adjust the OBA if necessary (*see OBA To Top Door Clearance in Section 4 of Volume 2 for this procedure*).