

SEEBURG

33-1/3 AUTO-SPEED UNIT, Type 33-1/3 ASU1

The 33-1/3 Auto-Speed Unit supplies 44-cycle AC power to the motor of the Select-O-Matic phonograph mechanism when 33-1/3 RPM records are played. The power is generated by a vacuum tube oscillator and power amplifier that are controlled through circuits associated with the phonograph motor.

In addition to the oscillator-amplifier and its power supply, the Unit includes a Power Relay, a Control Relay, controls for power output and frequency and a trip control circuit for operation of the phonograph trip circuit if the 44-cycle power supply should fail.

Two 12BH7-A, two 6L6GC output tubes, a 5U4-GB and one OA2 are the tubes used. One 12BH7 is the oscillator, the other is an amplifier and phase inverter for driving the push-pull 6L6-GC tubes. The output tubes operate with fixed bias supplied from a bias supply secondary on the power transformer and rectified by a selenium diode, CR751.

The oscillator is, essentially, a two-stage amplifier in which the output is fed back through condenser C755 to the first stage grid for regeneration and to its cathode for degeneration. The phase of the voltage to the grid is determined by the R-C combination consisting of C751, C752 and R752 in parallel and by C753, C754, R753 and R755 in series. At only a certain frequency will the phase relationship be correct for oscillation. The inverse feedback is applied to the cathode through R757 and R756. Amplitude stabilization is achieved by using the current-resistance characteristics of the 3-watt tungsten filament lamp that is in series in the cathode circuit. If the plate current increases, the lamp resistance increases and the inverse feedback ratio increases.

The current through the 3-watt lamp is not enough to cause its filament to "light up" so it should last indefinitely. If a replacement must be made, it may be necessary to select one having characteristics that will permit adjustment of the output voltage of the Unit. The lamps differ and with some of them, the output voltage will be higher or lower than can be compensated for with the output (*DRIVE*) control.

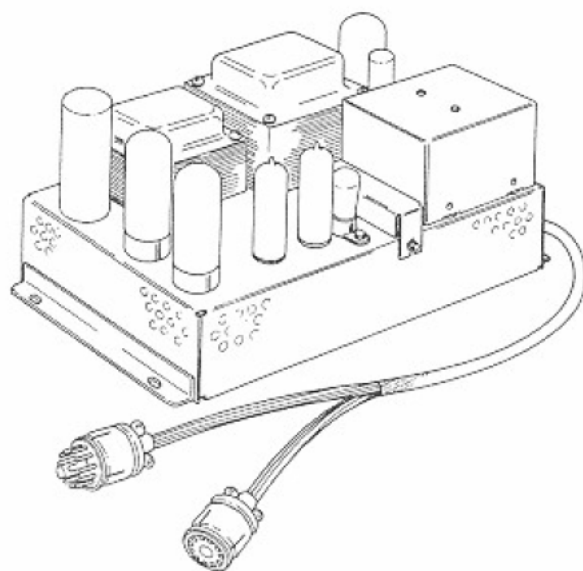

Figure 1.

The *SPEED* control, R755, adjusts the oscillator frequency. It establishes the effective value of resistance in the series R-C branch of the network through which voltage is fed to the first grid. The desired frequency, 44 cycles, is determined by using a strobe disc on the turntable of the phonograph.

The *DRIVE* control, R756, establishes a ratio of inverse feedback and is adjusted to provide oscillator output voltage that will drive the output stage of the amplifier to give approximately 90 volts when the phonograph motor is being driven. Test jacks adjacent to the controls on the Unit are for connecting a voltmeter.

The output voltage and frequency remain constant over a wide range of supply line voltage and load conditions because of the inherent stability of the oscillator and the use of negative feedback in the driver - phase inverter - output stages of the Unit.

The power Relay, K751, when energized transfers the phonograph motor connections from 60- to 44-cycle supply. It is controlled by a circuit that includes a single-pole, normally closed clamp arm switch that is actuated by the record clamp arm on the mechanism. The size of the record spindle-hole determines how far the clamp arm moves and whether or not the switch is actuated.

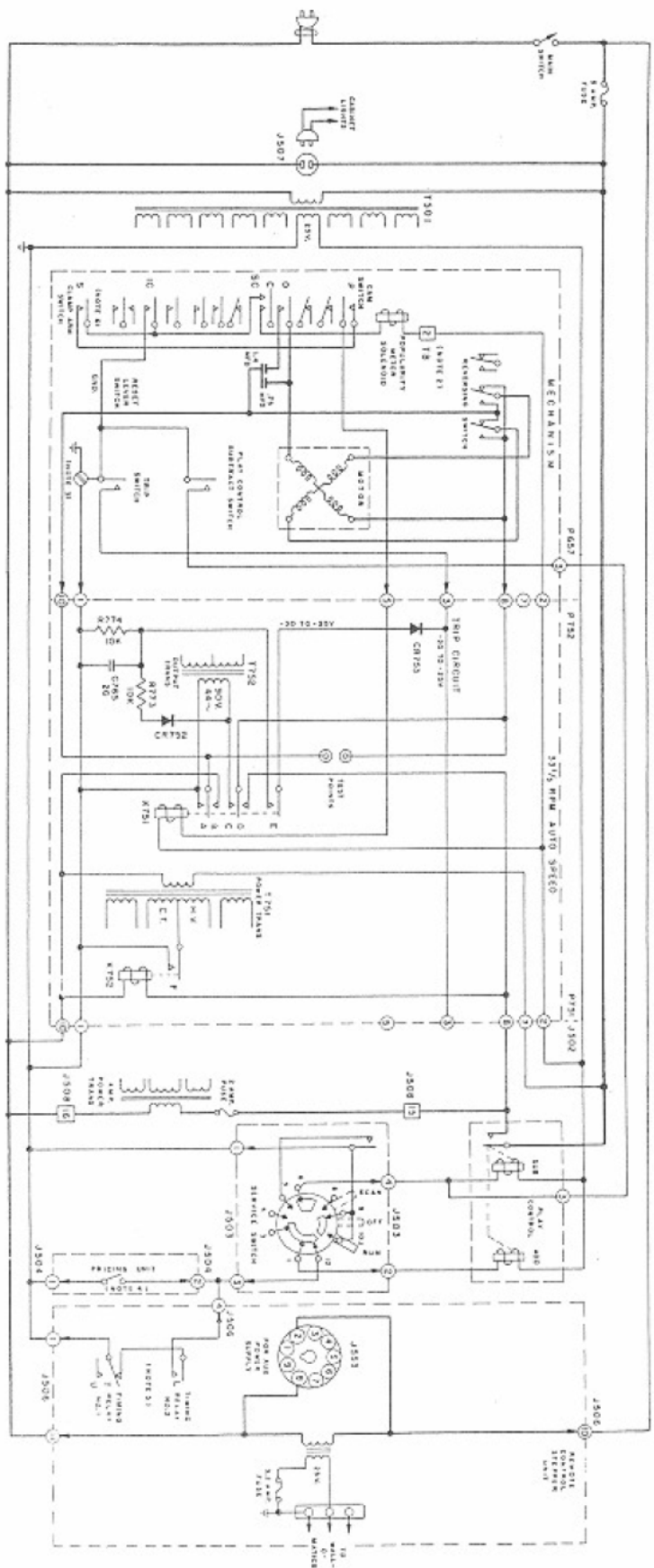

1. This symbol indicates a terminal connection. The terminal number in circle is contact or terminal number. Arrow indicates wiring from terminal.
2. This symbol indicates the number of the mechanism carriage terminal in box is terminal number. Terminal numbering is with bottom of arm.
3. Carriage ground connection below terminal strip.
4. Circuit momentarily closed when at electrical selector.
5. Circuit momentarily closed when hand lever in position. Selection is made by remote operation. Opens when arm record is changed.

Figure 2. Power and Control Wiring with 33-1/3 RPM. Auto-Speed Unit.

The 33-1/3 RPM record has a 5/16 inch spindle hole. It centers on the turntable with a 5/16 inch clamp arm centering pin and is held against the turntable by the face of the concentric 1-1/2 inch, 45 RPM centering "pin". When a 45 RPM record, with its 1-1/2 inch spindle hole, is played, the 1-1/2 inch diameter pin passes through it and the record is held against the turntable by the flat surface of the clamp disc. When a 45 RPM record is clamped, the clamp arm moves inward far enough to open the clamp arm switch. There is less arm movement when a 33-1/3 RPM record is clamped and the switch remains closed.

The clamp arm switch, as shown in Figure 2, is in series with a contact on the Cam Switch and the IC contact on the reset lever switch. It provides a 25 volt circuit for the Power Relay. The IC contact is closed when a record is playing and opened when the mechanism is tripped from play. The cam switch contact is closed only in the playing position. The clamp arm switch is closed only when a 33-1/3 RPM record is clamped. The only time the relay is energized, then, is when the mechanism is playing a 33-1/3 RPM record. At all other times - during transfer, scan and while playing a 45 RPM record, the relay is not energized and the motor is operating at 60 cycles.

The Control Relay, K752, controls the high voltage supply of the 44 cycle generator. It is energized at 115 volts from the 60 cycle line whenever the phonograph mechanism is in operation so the high voltage is not applied to the tubes during standby periods.

Contact E on the Power Relay closes when the relay is energized and applies 30 to 35 volts to the diode CR753 which, in turn, is connected to the grid of the trip 2050 in the phonograph. The circuit is shown in Figure 3. This negative voltage is in the reverse direction for the diode and is greater (more negative) than the 2050 bias supply so the normal bias voltage does not change. The 30 to 35 volts is derived from the 44 cycle supply through the diode (rectifier) CR752 and the voltage divider R774 and R773. When a 33-1/3 RPM record is not on the turntable, contact E will be open and the circuit from the 2050 bias supply through CR752 will be open.

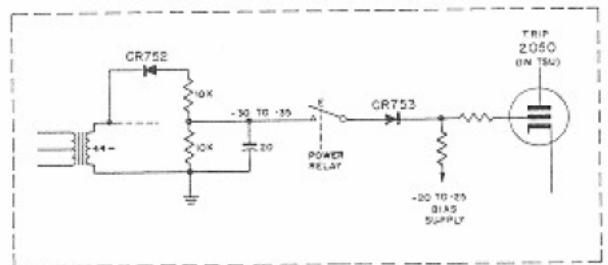
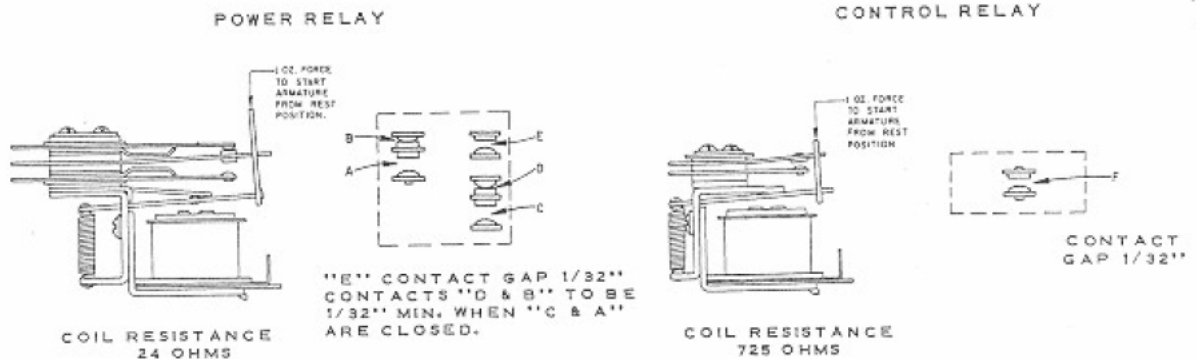

Figure 3. Trip Control Circuit.

If the 44-cycle supply should fail while a 33-1/3 RPM record is playing or if there should be no 44-cycle power available at the time the relay is energized, the bias for the 2050 will be grounded through CR753 and R774. The 2050 will then fire and the mechanism will trip from the play position. When the trip occurs, the IC contact of the reset lever switch will open, permitting the motor control relay to drop out so the motor is connected to the 60 cycle supply for continued operation.

RELAY ADJUSTMENTS



33-1/3 AUTO-SPEED UNIT, Type 33-1/3 ASU1

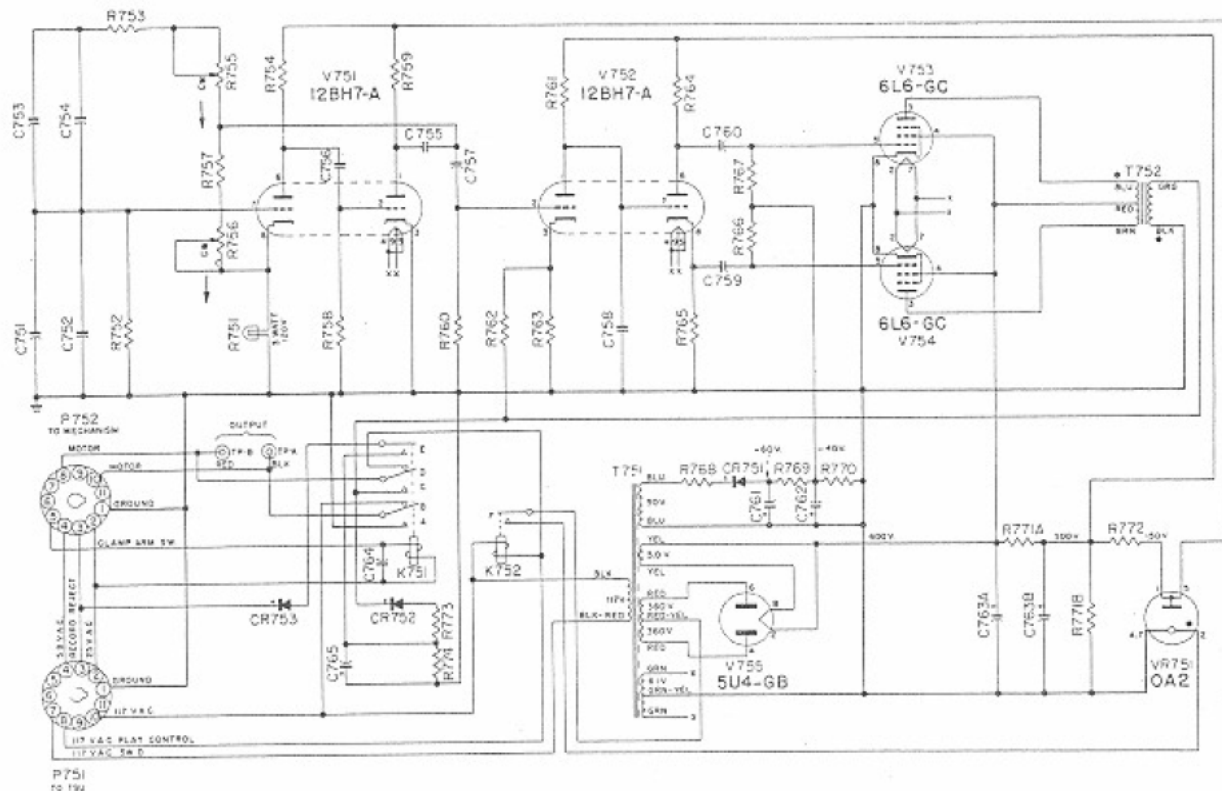

Schematic Diagram - 33-1/3 Auto-Speed Unit.

PARTS LIST

Item	Part No.	Description	Item	Part No.	Description	Item	Part No.	Description
C751	85104	1500 MMF 5% 500 V. Silver Mica		307440	Switch Stack (B,A)	R764	82782	47,000 OHMS 5% 1 W.
C752	85103	130 MMF 5% 500 V. Silver Mica	K752	307420	Control Relay	R765	82782	47,000 OHMS 5% 1 W.
C753	85104	1500 MMF 5% 500 V. Silver Mica		307439	Coil & Frame	R766	82666	100,000 OHMS 5% 1/2 W.
C754	85103	130 MMF 5% 500 V. Silver Mica		307438	Switch Stack (F)	R767	82666	100,000 OHMS 5% 1/2 W.
C755	87636	10 MFD 150 V. Lytic				R768	82418	330 OHMS 5% 1/2 W.
C756	86300	0.22 MFD 400 V. Paper	CR751	309390	Selenium Diode	R769	82575	11,000 OHMS 5% 1/2 W.
C757	86300	0.22 MFD 400 V. Paper	CR752	309385	Silicon Rectifier	R770	82639	22,000 OHMS 5% 1/2 W.
C758	86146	0.05 MFD. 600 V. Paper	CR753	309385	Silicon Rectifier	R771	81203	2000/25000 OHMS 10% 10/10 W.
C759	86296	0.15 MFD 10% 600 V. Paper				R772	81204	4,500 OHMS 10% 10 W.
C760	86296	0.15 MFD. 10% 600 V. Paper	R751	307426	120 Volt Lamp 3 W.	R773	82436	10,000 OHMS 5% 1/2 W.
C761	87668	20 MFD. 75 V. Lytic	R752	82579	2.2 Megohm 1% 1/2 W.	R774	82436	10,000 OHMS 5% 1/2 W.
C762	87680	50 MFD 60 V. Lytic	R753	82578	2 Megohm 1% 1/2 W.			
C763	87684	40/40 MFD. 50 V. Lytic	R754	82605	24,000 OHMS 5% 1/2 W.			
C764	86235	0.05 MFD. 200 V. Paper	R755	307425	500,000 OHM Pot	VR751	308005	OA2 Voltage Reg. Tube
C765	87668	20 MFD 75 V. Lytic	R756	307424	1,000 OHM Pot	V751	308126	12BH7-A Vacuum Tube
P751	249936	11 Prong Plug	R757	82611	3,000 OHMS 5% 1/2 W.	V752	308126	12BH7-A Vacuum Tube
P752	307445	8 Prong Socket	R758	82667	470,000 OHMS 5% 1/2 W.	V753	308643	6L6-GC Vacuum Tube
K751	307422	Power Relay	R759	82632	8,200 OHMS 5% 1/2 W.	V754	308643	6L6-GC Vacuum Tube
	307442	Coil & Frame	R760	82667	470,000 OHMS 5% 1/2 W.	V755	308506	5U4-GB Vacuum Tube
	307441	Switch Stack (E,D,C)	R761	82832	47,000 OHMS 5% 2 W.			
			R762	81205	10,000 OHMS 10% 7 W.	T751	307414	Power Transformer
			R763	82620	1,000 OHMS 5% 1/2 W.	T752	307416	Output Transformer

SEEBURG

33-1/3 AUTO-SPEED KIT, Type 33-1/3 ASU1 with SELECT-O-MATIC Q100 and Q160 Models.

The 33-1/3 Auto-Speed Kit, Part No. 508480 is for use with the Select-O-Matic Q100 and Q160 Models for playing intermixed 45 RPM. and 33.1/3 RPM., 7-inch records.

INSTALLATION:

1. Position the Auto-Speed Unit on the floor of the phonograph (Figure 1) and secure in position using four 10-32 x 3/4 inch Sems screws provided.
2. Unplug Mechanism Cable from socket J502 of Tormat Selector Unit and plug it into 11-prong socket, P752, of Auto-Speed Unit Cable.
3. Insert 11-prong plug, P751, of Auto-Speed Unit Cable into the Tormat Selector Unit socket, J502, vacated in step 2.

ADJUSTMENT:

1. Replace a record with the Seeburg 33-1/3 Auto-Speed Disc, Part No. 508487.

2. Remove Cover from Auto-Speed Unit Controls.
3. Select Strobe Disc on to the mechanism turntable and carefully prop pickup arm out of the way.
4. Adjust the motor speed to 33-1/3 RPM. using the Motor Speed Control and observing the Strobe Disc.
5. Connect an A.C. voltmeter to the Test Points and adjust the Motor Drive Voltage Control to 90 volts.
6. Recheck the motor speed and re-adjust if necessary.
7. Replace the cover on the controls and remove the Strobe Disc.
8. Load 33-1/3 RPM. Records and insert associated Programming Strips.
9. Install Decal, Part No. 484284.

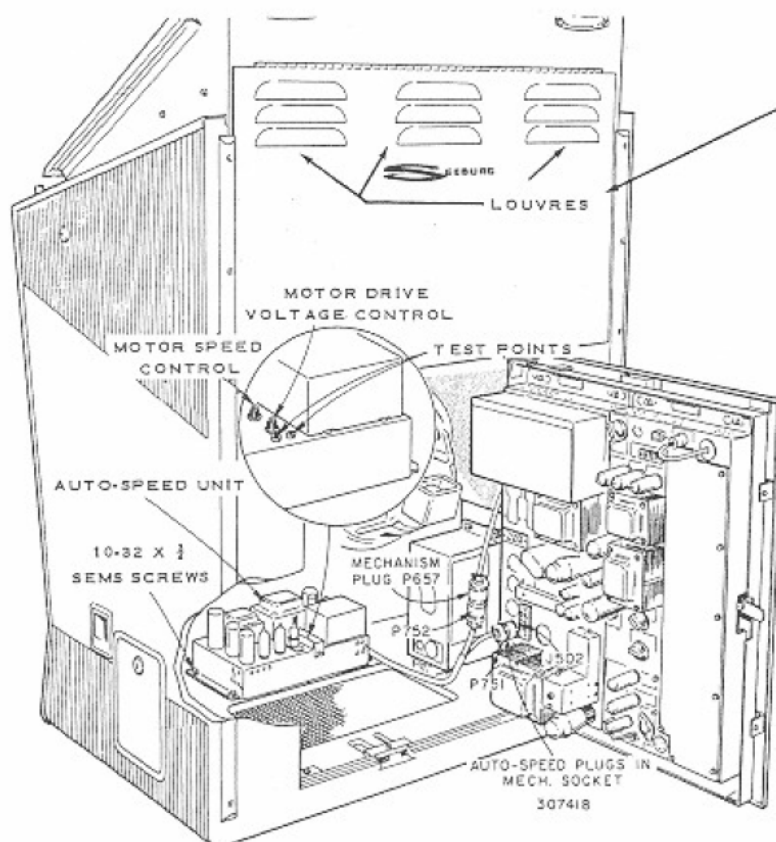

Figure 1. Auto-Speed Unit Installed

IMPORTANT VENTILATION NOTES

1. If access panel has no louvres, replace with Part No. 483143.
2. If no cabinet opening has been provided under the Auto-Speed Unit, cut as shown in Figure 2.
3. One inch minimum clearance between bottom of phonograph cabinet and floor or carpet; use caster supports if required.
4. Two inch minimum clearance from back of phonograph to wall, use spacers if required.
5. All ventilation holes must be free of paper, labels and other obstructions.

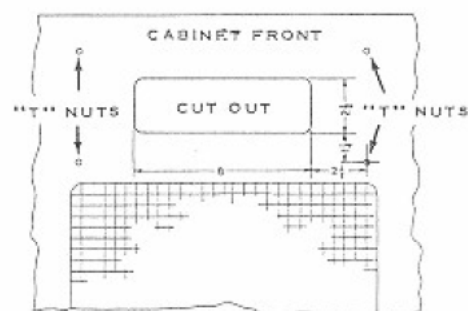

Figure 2. Cabinet Opening

MODIFICATION OF SELECT-O-MATIC MECHANISM FROM CODE A TO CODE B

Clamp Arm Switches wired as in Code A Mechanisms (long contact to ground) cause the mechanism motor to stop completely in the event of Auto-Speed Unit failure. Code B mechanisms will trip and move to another record. Code B mechanisms can be identified by a rubber bumper on the end of the clamp arm adjusting screw or an insulator on the switch blade.

The Clamp Arm Switch wiring revisions associated with the Code B mechanisms are such as to cause the mechanism to trip from play position in case of Auto-Speed Unit failure while a 33-1/3 RPM record is playing and permits the motor to continue operation at 60 cycles.

The following procedure details Code A to Code B modification requirements:

1. Remove the wire connecting the Clamp Arm Switch to a ground lug.
2. Remove the Pickup Arm Assembly from the mechanism.
3. Add a wire from the switch terminal vacated in step 1 to the lower (No. 2) IC contact of the Reset Lever Switch and route as shown in *Figure 3*.
4. Replace the Pickup Arm Assembly.
5. Replace the existing Clamp Arm Switch adjusting screw with shorter screw, Part No. 914725, and Rubber Bumper, Part No. 245983.
6. Adjust the Clamp Arm Switch so that with mechanism in Scan position, the switch is closed; and in Play position with a standard 45 RPM (1.5 inch hole record) clamped between the turntable and clamp Arm Disc, the Clamp Arm Switch gap is 1/32 inch.

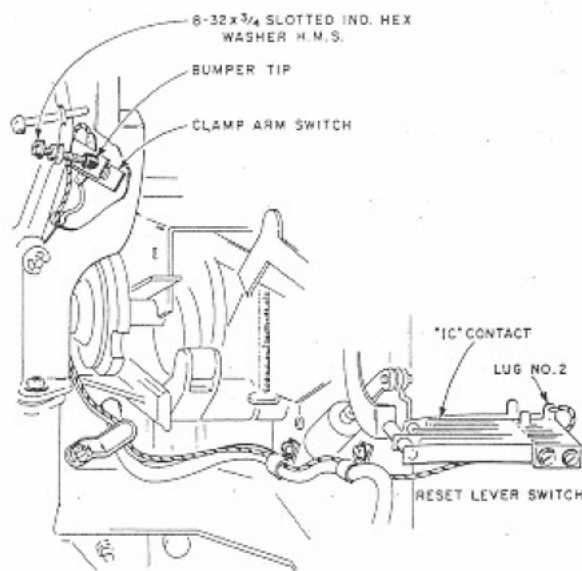

Figure 3. Clamp Arm Switch Rewiring