

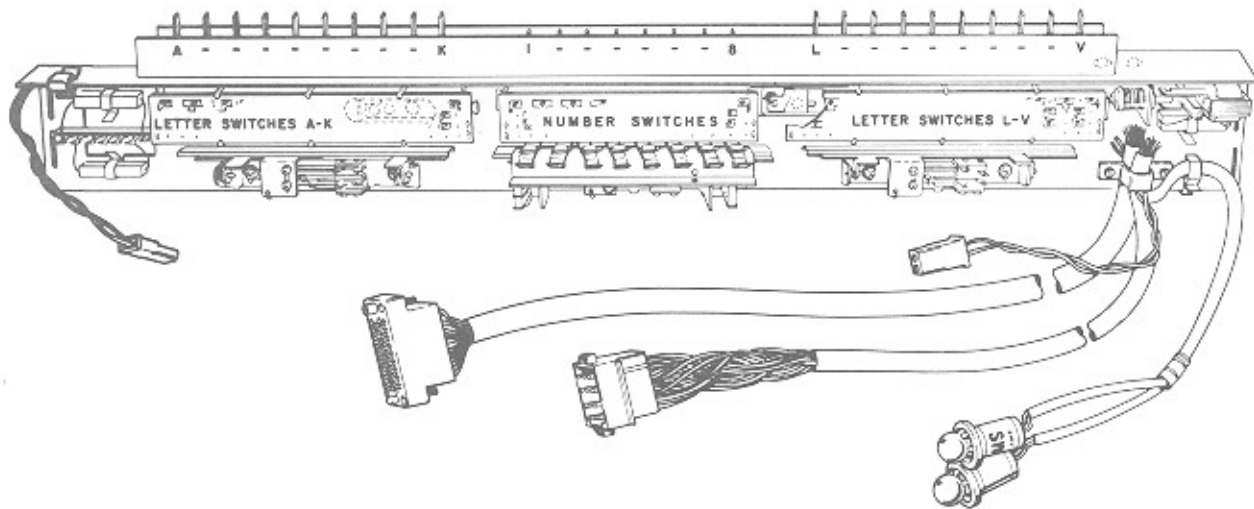

## TORMAT ELECTRICAL SELECTOR, Type TES1610-56



The Tormat Electrical Selector, Type TES1610-56 is part of the Seeburg Tormat Selection System. The principal functions of the selector is to connect a letter and a number circuit of the Tormat Memory Unit into a selection write-in circuit and to complete a circuit that initiates the operational sequence of the system. These functions are performed when two of the selection switches are operated by pressing a lettered selector key and a numbered key.

The principal parts of the selector include three selection switch assemblies, a latch bar solenoid, credit indicating lights, three start and hold switches each of which has two pairs of contacts, a write-in and pricing switch, a latch release switch, a two-pin plug for connecting a key release button and a two-pin plug for connecting a coin lockout solenoid.

The credit indicating lights illuminate the selection information window that is in the selector panel casting at the right of the selector keys. They are 6-volt lamps operated at 25 volts through 65-ohm resistors.

The latch bar function is to hold a selection switch (and selector key) in the pressed-in position when a selection is being made and to release it when the selection operation sequence is completed. The bars in the two letter switch assemblies are coupled end-to-end so they operate as a single continuous bar. The latch bar of the number switch is independent of the letter

switches but the bars in both letter and number switches are linked to and controlled by the latch bar solenoid. The linkage between the solenoid and the bars is spring loaded so the bar position permits free in and out movement of the selection switches when the solenoid is not energized. The solenoid is energized when credits are set up in the phonograph and the bars move to a position in which they will hold a pressed-in switch in the operated position. In the letter switch groups, however, the bars are designed so a latched-in switch will be released if another switch in the same letter group is pressed in. The number switch group is designed so a latched-in switch cannot be released until the latch solenoid is de-energized, releasing all switches.

The shafts or stems of the selector switches extend through the switch frame. They operate a treadle bar when a selector key is pressed and the treadle bar, in turn, operates a switch consisting of a spring-leaf switch and a snap-action, over-center switch. One switch is associated with each of the three selection switches and operates when a selector key is pressed. The three spring-leaf switches in the three start and hold switches are parallel connected and are part of a timing relay holding circuit that is completed through interlocking contacts on the relay when any one of the selector keys is pressed. These switches are the Hold Switches, contacts 1S1, 3S1 and 5S1.

## TORMAT ELECTRICAL SELECTOR, Type TES1610-56

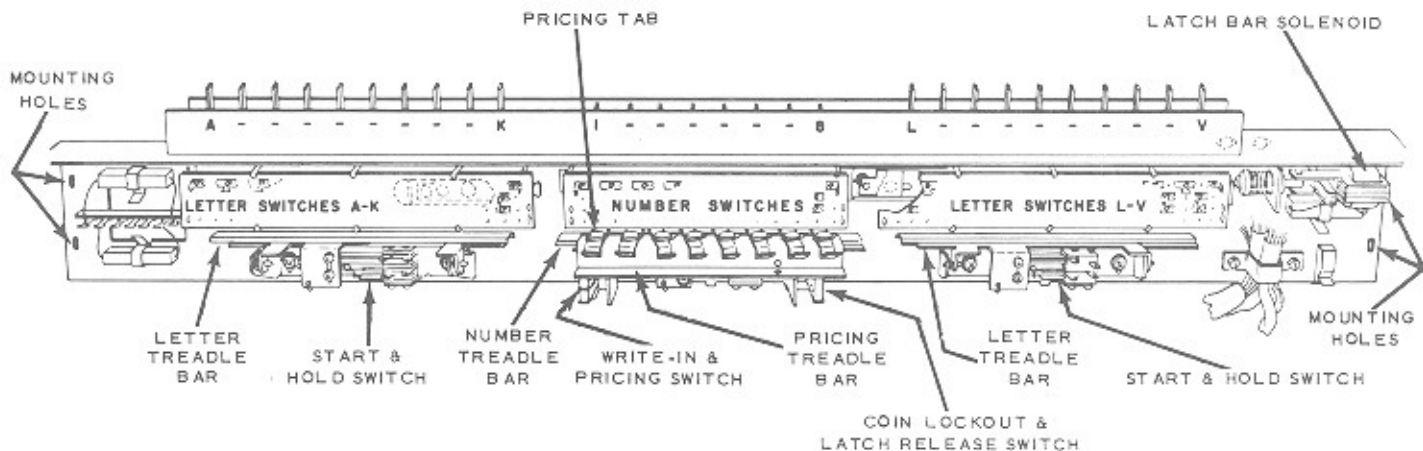

The snap-action switches are the Starting Switches, contacts 1S2, 3S2 and 5S2. The 1S2 and 5S2 contacts are operated by the Letter Selection Switches and are parallel connected so one or the other closes whenever a Letter Selector Key is pressed. The 3S2 contact is closed by pressing any Number Selector Key and is in series with the parallel connected 3S2 and 5S2 contacts. These contacts are part of a circuit that include a Subtract Solenoid or a Cancel Solenoid in the phonograph's Pricing Unit. When a letter key and a number key are pressed, the starting switches complete the circuit to the solenoid which, when energized, closes switch contacts that control the power to the Tormat Memory Unit and the timing relay. They also close, momentarily, the circuit for a play control add solenoid that, in turn, controls, through a play control unit, the power to the mechanism motor.

The Write-in and Pricing Switch together with the Latch Release Switch are operated by a pricing treadle bar which in turn is actuated by the number selector switch stems. The 2S2 and 2S3 contacts of the Pricing Switch, S3407, are in the "starting" circuit of the Electrical Selector. The 2S3 contact is normally closed and connects the starting circuit to the subtract solenoid in the Album Pricing Unit. Tabs on the Pricing Treadle Bar may be positioned so that the switch is actuated when a number selector button (1 to 8) is pressed. When actuated, the switch transfers the starting circuit, through the 2S2 contact, to the motor circuit in the Album

Credit Assembly of the Album Pricing Unit, thus providing for album pricing.

The normally closed 2S1 contact in the Pricing Switch is in the write-in circuit of the phonograph and is in parallel with a pulse switch (2P2 contact in the Album Credit Assembly). When the Pricing Switch is actuated, the 2S1 contact opens and permits the 2P2 contact in the pulse switch to function for write-in control when an Album is selected.

The Latch Release Switch, 4S1 contact, is normally open and the 4S2 contact is normally closed to maintain a circuit for 25 V. from the Single Credit Switch (in the Pricing Unit) to the Key Release Button and the latch solenoid. This switch is not disturbed when a single selection is made; however, when an album is selected, the pricing treadle bar activates the switch, the 4S1 contact closes to complete a circuit from the Album Credit Switch (in the Pricing Unit) to the Key Release Button and the latch solenoid, the 4S2 contact opens to break the circuit from the Single Credit Switch (in the Pricing Unit). Effectively the switching de-energizes the latch bar solenoid permitting the selector keys to unlatch if an Album selection is attempted with insufficient album credit on the phonograph.

If a number button is pressed before a letter button and it is desired to switch to another number, pressing the Key Release Button, located on the selector panel, will de-energize the latch bar solenoid, the selector keys will unlatch and a new number selection can be made.

## TORMAT ELECTRICAL SELECTOR, Type TES1510-56

### REMOVAL OF SELECTOR

The entire unit may be removed for service by pulling out the connecting plugs at the ends of the cable and removing the four nuts that are located at the extreme edges of the assembly.

When replacing the selector in the cabinet it should be fastened securely. It should be positioned so there is a minimum of clearance between the ends of the selection switch shafts and the back of the selector keys. If, however, it is too far toward the keys the selection switches

may not return far enough to the released position to open the timing relay circuit that is operated by the Hold Switches. If it is too far from the keys, the keys will be loose and may settle.

### LUBRICATION

Oil all pivots with one drop of Seeburg No. 53014 Select-O-Matic Special Purpose Oil. Use Aero Lubriplate sparingly on the surfaces of the latch levers where they bear on solenoid plunger and the latch bars. (*Aero Lubriplate and No. 53014 Oil is available from your Seeburg Distributor.*)

### SPRING ADJUSTMENTS

#### 2 OZ. FORCE TO MOVE PRICING TREADLE BAR FROM NORMAL REST POSITION

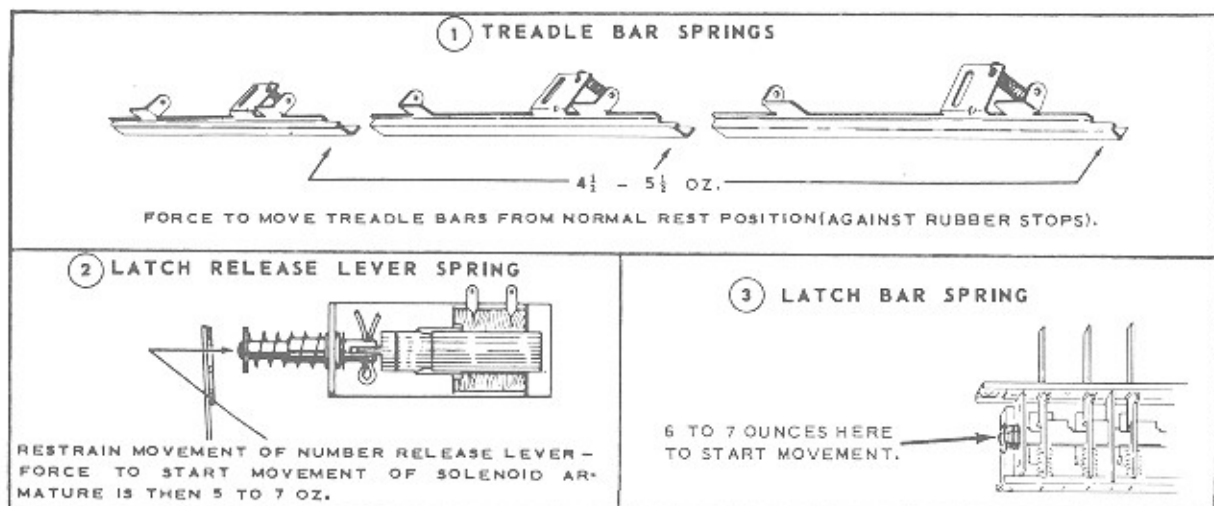
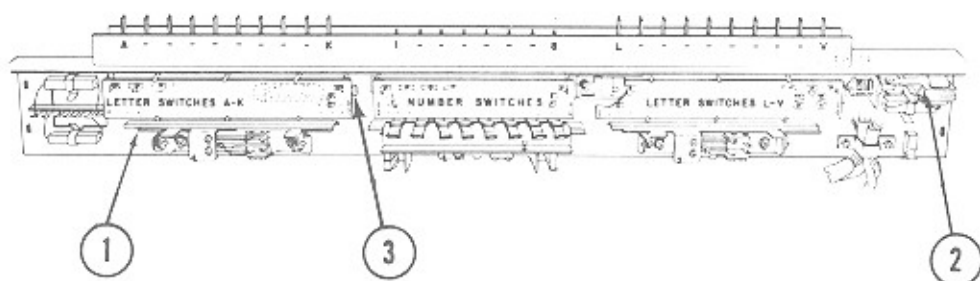

TORMAT ELECTRICAL SELECTOR, Type TES1610-56  
 ADJUSTMENT NO. 1 - LETTER SWITCH L-V

This adjustment positions the latch bar in the L-V LETTER selector switch so that when credits are established, the selector switches will latch in the pressed-in position but permit change of selection by operating another switch in the L-V group.

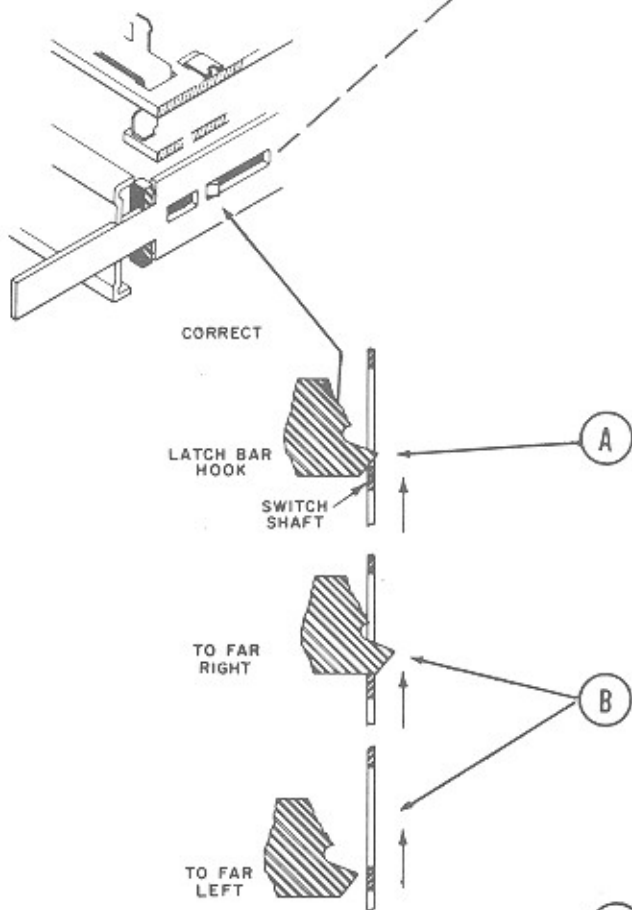
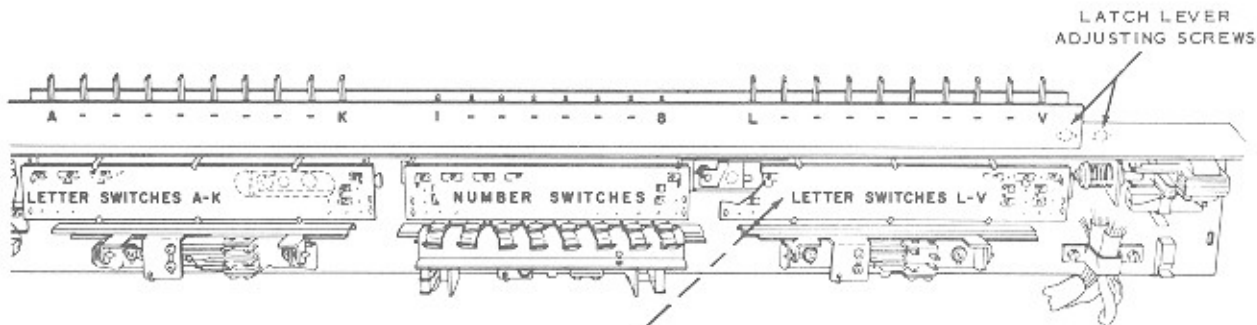

*NOTE: When making this adjustment the latch bar solenoid must be in the energized position, all linkage and bars must be free to move without binding and there should be a gap between the latch release lever and the end of the latch bar solenoid plunger rod.*

Loosen the two adjusting screws holding the latch release lever bracket and position the bracket so the tips of the latch bar hooks extend 1/64 inch through the openings in the selector switch shafts.

If the bracket is too far to the right, the selector keys will be locked out. If the bracket is too far to the left, the selector keys will not latch or the latching will be erratic.

After the correct position of the bracket has been made, the bracket holding screws must be securely tightened.

ADJUSTMENT NO. 2 - LETTER SWITCH A-K

This adjustment positions the latch bar of the A-K LETTER SWITCH so these lettered selector switches will operate in the same manner provided for the L-V LETTER SWITCH in Adjustment No. 1. The adjusting screws are accessible through a hole in the bottom of the Selector frame.

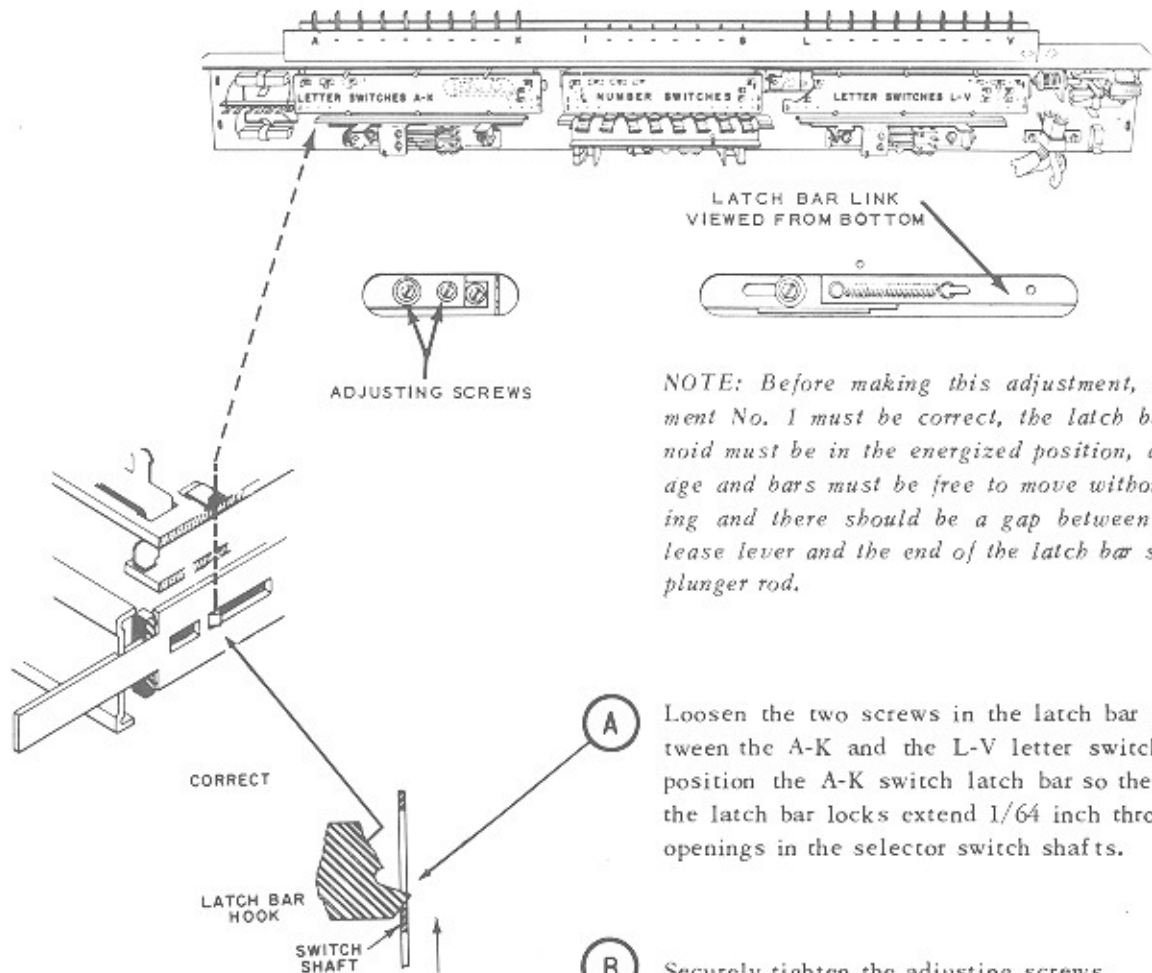

*NOTE: Before making this adjustment, Adjustment No. 1 must be correct, the latch bar solenoid must be in the energized position, all linkage and bars must be free to move without binding and there should be a gap between the release lever and the end of the latch bar solenoid plunger rod.*

- (A)** Loosen the two screws in the latch bar link between the A-K and the L-V letter switches and position the A-K switch latch bar so the tips of the latch bar locks extend 1/64 inch through the openings in the selector switch shafts.
- (B)** Securely tighten the adjusting screws.
- (C)** Check this adjustment by pressing a lettered switch in the A to K group and one in the L to V group while manually holding the latch bar solenoid in the energized position, then slowly release the solenoid. Both lettered switches should release at the same time. If the A-K latch bar is too far to the left, the switch in the A-K group will release first; if the A-K latch bar is too far to the right, the switch in the L-V group will release first.

TORMAT ELECTRICAL SELECTOR, Type TES1610-56

ADJUSTMENT NO. 3 - NUMBER SWITCH

This adjustment positions the latch bar in the NUMBER selector switch so that when credits are established, the numbered selector switches will latch in the pressed-in position but permit change of selection by operating another numbered switch.

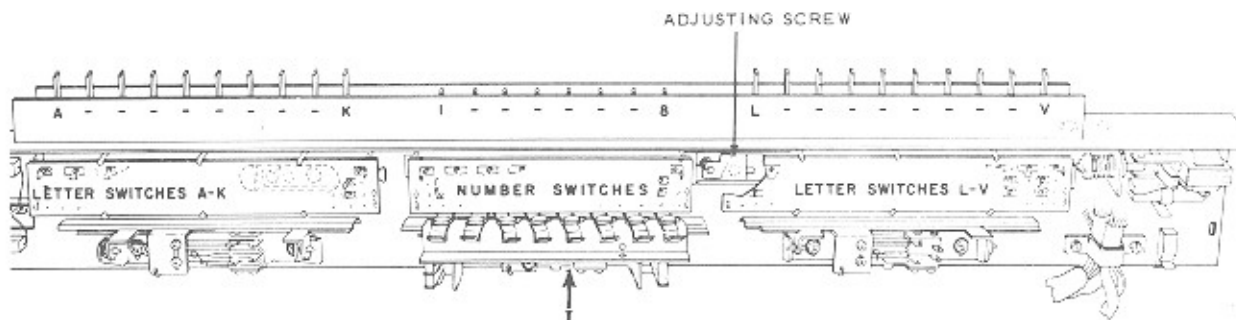

NOTE: When making this adjustment the latch bar solenoid must be in the energized position, all linkage and bars must be free to move without binding and Adjustments No. 1 and No. 2 must be correct.

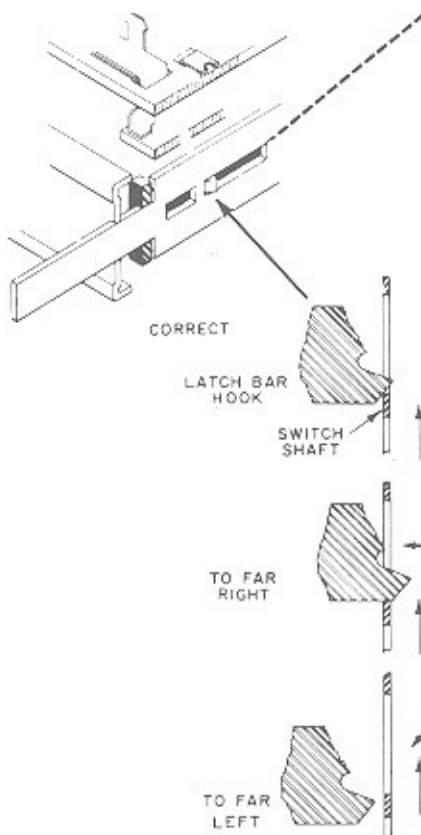

(A) Loosen the screw that holds the number latch lever to the letter latch lever and position the number latch lever so the tips of the latch bar hooks of the NUMBER selector switches extend 1/64 inch through the openings in the selector switch shafts.

(B) If the forward end of the number latch lever is too far to the right, the selector keys will be locked out. If the lever is too far to the left, the selector keys will not latch or the latching will be erratic.

(C) When the correct position for the latch lever has been established, the screw that holds the letter and number levers together should be securely tightened.

TORMAT ELECTRICAL SELECTOR, Type TES1610-56  
TREADLE BAR AND SWITCH ADJUSTMENTS

NOTE: All treadle bars should move freely on their pivots to rest against the rubber bumpers and should have a small amount of end play.

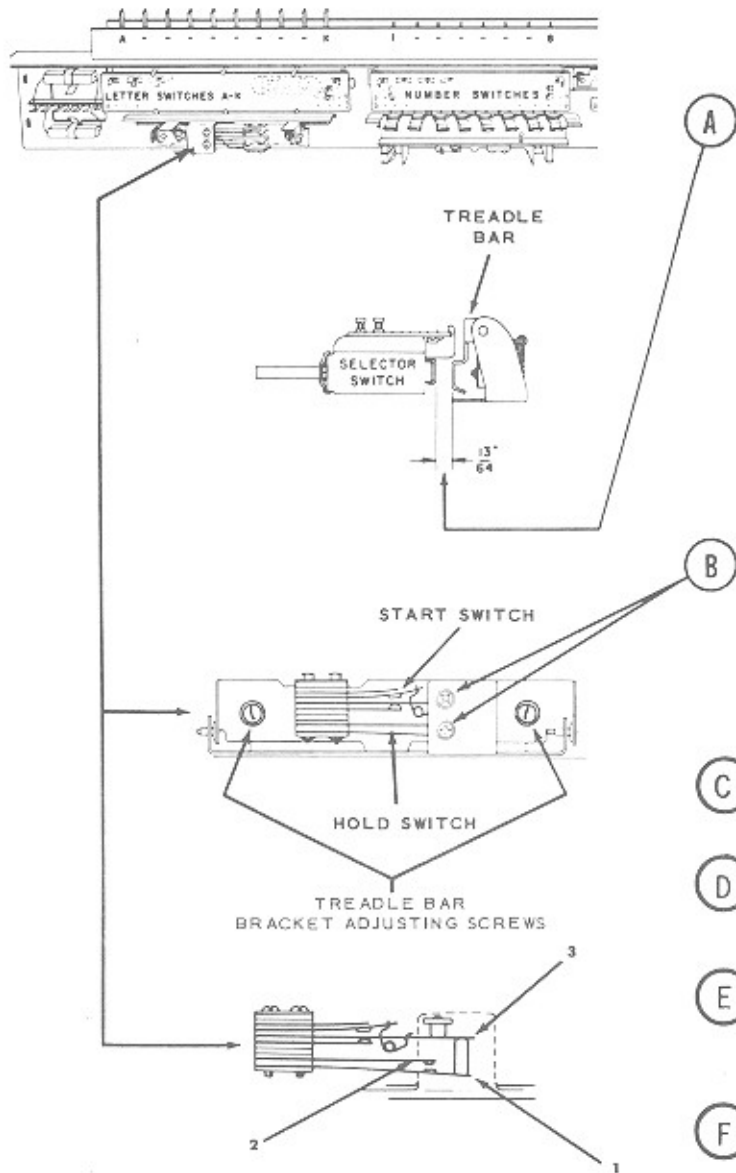

With the treadle bar against the rubber bumper in the treadle bar adjusting plate, position the plate after loosening the treadle bar bracket screws so there is 13/64 inch (.203 inch) separation between the treadle bar and the frame of the selector switch. Use the shank of a No. 6 (.204 inch) or No. 7 (.201 inch) or a 13/64 inch twist drill for a spacing gage.

The timing of operation of the snap action Start Switches is adjusted by positioning the brackets for the entire switch assembly. DO NOT ADJUST BY BENDING THE SNAP ACTION SWITCH BLADES.

Loosen the bracket holding screws B, and position the switches so the Start Switch contacts close when the selector switches have approximately 1/32 inch more travel before latching by latch bars.

With all selector switches released:

(C) Adjust Blade No. 1 so its fibre lift bears against Blade No. 3 approximately 2 oz. (50 grams)

(D) Adjust Blade No. 2 for 1/64 inch to 1/32 inch contact gap.

(E) Readjust force of Blade No. 1 against Blade No. 3 so Blade No. 2 moves approximately blade thickness (1/64 inch) when contacts close.

(F) Check operation: Hold Switch must close before Start Switch closes and open after Start Switch opens.

Pricing, Coin Lockout & Latch Release Switch Adjustments

With no selector switches operated, set up minimum gaps as shown.

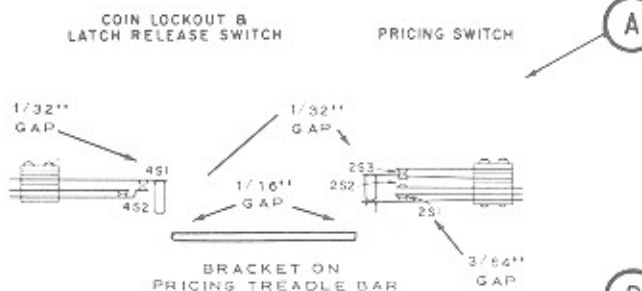

(A) With a Pricing Tab set for "Album Play", operate selector switch, note that 2S1 contact opens before Start Switch closes. 2S3 contact opens after 2S1 contact opens. 2S2 contact, normally open with 1/32 inch minimum gap, to close before Start Switch closes.

NOTE: Switching of all contacts to take place before number Start Switch closes.

(B) Contact pressure as follows:

4S1 and 4S2 — 1 ounce.

2S1, 2S2 and 2S3 — 1½ ounces.

