

Please read before using this equipment

OWNERS MANUAL

REALISTIC[®] COMMUNICATIONS

PATROLMAN PRO-3A VHF/UHF 3 BAND MONITOR RECEIVER

PROFESSIONAL
SERIES

Catalog No.
20-452



Sold, serviced and
guaranteed from
coast-to-coast

COPYRIGHT[®] 71

Manufactured in Japan for Radio Shack  A Tandy Corporation Company, Fort Worth, Texas 76107

PRO-3A Monitor Receiver

General Description

Your PRO-3A Patrolman Receiver tunes three bands allocated by the FCC to service and business communications. They are:

VHF LO	30 – 50 MHz
VHF HI	152 – 174 MHz
UHF	450 – 470 MHz

These bands carry a remarkable variety of business and emergency radio services. Best known are Fire and Police, but others include Forestry/Conservation, Hospitals, Physicians, Emergency Communications. A list of sixteen general classes appearing in the FCC regulations is given on page 2, and every class includes several users. No individual allocations are given there because generally all bands are used by all services.

Designed for the user, the PRO-3A offers more utility than any other receiver in its class. It is large enough for base station operation, and has all necessary features of SQUELCH, narrow-band filter, and several-band operation. It also is light enough to be carried into hard-to-reach areas or mounted in cars, trucks, boats or airplanes. And it uses a remarkably small amount of power. For example, a single car battery should power the PRO-3A for better than 200 hours of continuous operation before needing a recharge.

The PRO-3A is an extremely sensitive receiver. With a full complement of circuits and components, it is nearly as sensitive as any receiver for its tuning ranges can be. Its natural noise level is comparable to a one-third microvolt signal-and that limiting noise can be heard merely by turning up the audio volume control.

This great sensitivity is necessary for remote areas and in emergency operating conditions. But circuits designed for high sensitivity are often subject to intermodulation problems if used in very strong-signal areas. Also, adjacent-channel transmitters are more likely to be operating in urban and metropolitan areas than in remote regions. The PRO-3A features a really effective 10.7 MHz filter, placed in its IF input circuit. This reduces or eliminates adjacent-channel or strong-signal interference.

Another filter is included to improve the readability of very weak signals. A low-pass audio filter, also controlled from the front panel, can be switched in to reduce the effects of inherent circuit noise when listening to a voice signal that is "buried in the noise." By reducing the audio bandwidth of the receiver, the filter emphasizes the desired audio signal.

The PRO-3A is remarkably easy to use. But it is an up-to-date, complex circuit consisting of 25 separate transistors plus 20 more in its integrated-circuit IF section, 10 diodes and one zener. All are mounted on a steel chassis, which in turn is installed in a steel cabinet provided with a mounting bracket designed for mobile installation. The PRO-3A is an important engineering achievement, but designed for practical applications.

GUARANTEE: The REALISTIC guarantee is stated on the Fact Tag packed with the equipment. It is in effect from coast to coast. At any time, REALISTIC equipment may be restored to new condition with original parts with MINIMUM delay anywhere in the U.S.A., usually in your own neighborhood. It is NOT necessary to return REALISTIC equipment to our laboratories in 98% of the cases.

PRO-3A Monitor Receiver

General Specifications

Note: These are given in general form only, since REALISTIC does not believe in buying to or designing to numerical specifications. The latter are subject to variables not clearly related to performance, just as selectivity, the number of transistors or IC's indicate in an average way the quality of a circuit but do not prove one circuit will outperform another in real operating conditions. Our philosophy is that a piece of equipment should be evaluated in terms of what it does for the purchaser, its quality and relative value being based upon merit and observed performance in real life. Thus REALISTIC designs toward achieving a certain result, ... regardless of cost, regardless of lab measurements, regardless of competitive advertising claims. Results are determined by your application of our finished result. Good installation is extremely important since a poorly installed or a wrongly placed antenna can result in a 90% or even greater signal loss. And an inadequate speaker system can be almost as effective in reducing equipment performance. The following figures are offered only as a guide, not as a guarantee of equipment performance:

This equipment is designed to operate from either 117 VAC or 12 VDC negative ground. If it fails to operate, and there is no clear reason for the failure, first check the supply switch. This switch entirely disconnects the supply components that are not in use. Also, before connecting the PRO-3A receiver to a DC power supply, check the voltage polarities. Attempting to operate the negative-ground PRO-3A from one of the rare positive-ground automotive or boat electrical systems, or from a wrongly connected battery, will at least blow a fuse. It may do further damage, so that expensive and time-consuming repairs are necessary before the PRO-3A can be used again. The Radio Shack warranty does not apply to any damage caused by this, inadequate lightning protection, or other improper connections.

General Specifications List

- Tuning Ranges: VHF LO, 30-50 MHz. VHF HI, 152-174 MHz. UHF, 450-470 MHz.
- Antenna Connections: 50-ohm coax. One for VHF LO and HI bands. Another for UHF band.
- Sensitivity: 1 microvolt for 20 dB quieting.
- Selectivity: 5 KHz position—6 dB @ ± 5 KHz. 15 KHz position—3 dB @ ± 35 KHz.
- IF frequency: 10.7 MHz.
- Audio Output: 2 watts into 8 ohms. The PRO-3A will operate into a 4 thru 16 ohms load.
- Solid-state Components: 25 transistors, 2 IC, 10 diodes and 1 zener.
- Power Input: 117 VAC 60 Hz or 12-15 VDC, negative ground only.

How To Operate The PRO-3A Monitor Receiver

The PRO-3A Monitor Receiver is a remarkably easy receiver to use. Basically, it is an FM receiver, and works like one. Its additional SQUELCH and filter controls, bandswitching capability, and antenna and power requirements are easily met. Highly stable, the PRO-3A, once mastered, is a reliable and useful communications tool.

A good installation will make the most of the PRO-3A's capabilities. Loss of the tiny signal at the antenna is avoided by correct antenna adjustments and by installing a good quality foam coax cable. Where noise problems must be overcome, the PRO-3A's audio output can be fed to low-impedance audio headphones or to an external loudspeaker.

The PRO-3A is powered by either 12-15 volts DC or by 117 VAC 60 Hz, whichever is most convenient. In case of difficulty or uncertainty, the installation problems are best handed over to an experienced technician or engineer. The following assumes a good PRO-3A installation, and is appropriate for first-time operation or for determining if a possible malfunction might actually be a result of improper control settings.

The first step is a quick check of the installation. Antenna jacks are checked for connections to the correct antennas. The AC or DC power source should be operating, and providing the correct voltage. If DC is to be used, it must be of the correct polarity. (See page 5)

On the front panel the controls should be preset as follows before turning on the receiver. Tuning controls are at any setting. The VOLUME control, SQUELCH, SELECTIVITY controls are full counterclockwise. The AF FILTER switch is pushed down on the OUT side.

It is suggested if one can anticipate the frequency band to be used at turn on time, that the band switch be pre-selected to this LO, HI or UHF position as even when the power switch is turned OFF, the tuning section for this band is electrically energized and will thus provide lowest frequency drift possible when the receiver is turned ON.

Turning the VOLUME control clockwise should result in a mechanical click as the knob goes past the power switch detent, and the power goes on. Gradually advancing the knob clockwise will result in a soft and then increasingly loud rumbling hiss from the PRO-3A's monitor speaker or from the external headphone or speaker. After getting the feel of this control, it should be turned back to a setting that gives a perceptible but quiet hiss from the speaker.

The next step is to tune the band for a signal. Several passes may be necessary, since stations in the communications bands transmit only when they have a message and do not radiate even a carrier between transmissions. At this point other stations should be sought out, and their positions logged using the 0-100 logging scale. These stations can be identified later.

The familiarization with tuning can be repeated on all bands. Slight variations in noise level will be noted as the PRO-3A is tuned over its ranges.

Next, the PRO-3A should be tuned to any station and the SQUELCH control slowly advanced by turning it clockwise. Two key settings will be found. The first is the setting at which receiver noise is no longer heard but the station is heard at normal volume when it comes on the air. And the second setting will be one at which the station is not heard at any time.

These settings change with receiving conditions and with the band in use. For a strong station they are far apart, coming close together for weak signals. And a too-high accidental setting of the SQUELCH control will cause the PRO-3A to act as if it is not working. In case of trouble the first step is to return the SQUELCH knob to its full counterclockwise position. After practicing with this control it should be returned to its fully off position.

To practice with the SELECTIVITY control, tune in a station with this control in its 15 KHz position. Then advance this control to its SHARP or 5 KHz position. If the signal disappears the receiver tuning should be corrected. The PRO-3A's tuning is now very sharp, an indication of how close an unwanted signal can be without causing interference. This filter should also be tried if the PRO-3A is troubled by noises of uncertain origin. If these originate in strong-signal intermodulation, this setting should remove them. The 5 KHz position of this switch may also be tried when listening to an extremely weak signal.

This completes the "guided tour" of the PRO-3A receiver. In practice, all controls are used whenever their functions seem to be required.

Table of FCC Listed Services

Using VHF and UHF Bands

- Highway Maintenance Radio
- Forestry/Conservation
- Special Emergency
 - hospitals
 - ambulance and rescue
 - physicians and veterinarians
 - disaster relief
 - communications standby
 - school buses
 - beach patrols
- Power Radio
- Petroleum Radio
- Forest Products
- Motion Picture
- Relay Press
- Special Industrial Business Radio
- Manufacturers Radio
- Telephone Maintenance
- Motor Carrier
- Railroad Radio
- Taxicab
- Automobile Emergency
- ESSA Weather Broadcasts on 162.55 MHz and 162.450 MHz

Cutting instructions for UHF and VHF Antennas

The Radio Shack No. 20-177 antenna is a one quarter (152-174 MHz) or five-eighths (450-470 MHz) wave vertical designed for automotive trunk lid mounting. A special clamp in the antenna base fits into the space between lid and car body so that no hole cutting is required. Complete installation instructions are supplied with the antenna.

Minimum distance from antenna to edge of the metal mounting surface is preferably five or more antenna lengths. The two charts at the right indicate most efficient lengths, as measured from the tip of the antenna to the top of the set screw fitting.



The antenna length is adjusted to 5/8 wavelength at 450-470 MHz to improve its horizontal gain at a slight cost in high-angle gain. Its practical effect is about equal to a doubling of the transmitter power.

Antenna reliability will be improved if at assembly all contacting metal surfaces are cleaned and then coated with a thin layer of water pump grease or equivalent. The base fittings should be dismantled, cleaned, and checked about once per year.

CUTTING 20-177 ANTENNA

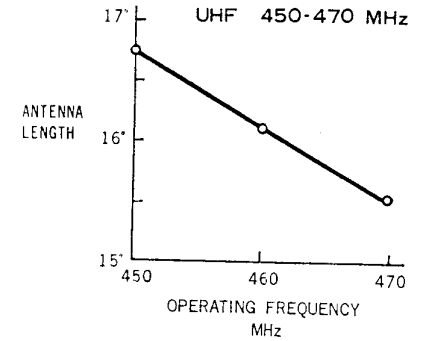
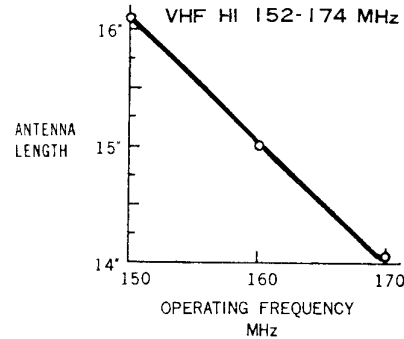

CUTTING 20-176 ANTENNA

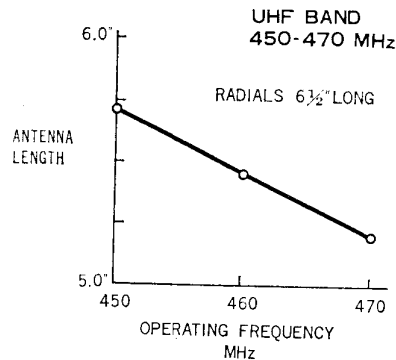
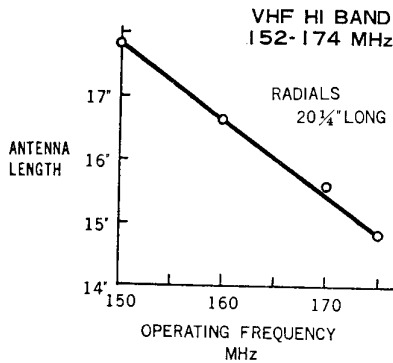

The Radio Shack No. 20-176 antenna is a wideband quarter-wave ground-plane antenna for 152-174 MHz or 450-470 MHz. It is designed to be used at fixed or portable stations. For best performance at a given frequency its whip and radials should be cut as follows.

During installation all four radials are cut to 20 1/4" (152-174 MHz) or 6 1/2" (450-470 MHz). They are removed from the assembly, the four end balls pulled off, and each radial is cut to the correct over-all length. Then the balls are tapped back on.

Next, the vertical radiator top plug is removed, and the radiator overall length trimmed to the value given in the cutting chart. After cutting, the antenna is ready for assembly and installation.

For best performance this antenna should be installed ten or more vertical radiator lengths away from any large metal objects. Wires, lightning protection systems, metal roofs, and large vehicles moving or stored nearby may influence quality of the received signal. If performance of the receiver system seems poor compared with that of other similar installations, the antenna should be moved.

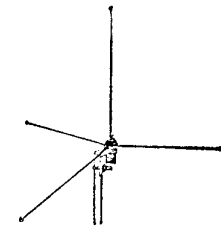

UHF and VHF Antennas

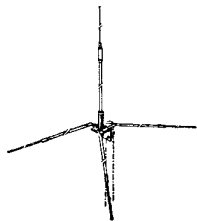

Dual Band Ground Plane

For outdoor use. 3 heavy-duty, low resistance aluminum elements. 2-section vertical radiator, matching transformer. Mounting bracket. Accepts PL-259. 20-015, 6 lbs.



Indoor Hi-Lo Antenna

Plug-in type. For indoor use. Rugged construction, center loaded coil. Telescoping whip, 40" extended, 16" collapsed. Terminates with pin-type plug. 21-161, 2 lbs.



Dual Band Cowl-Mount

For mobile use. Chrome telescopic whip (55" extended, 36" collapsed), mounted on swivel base. Center loaded weatherproof coil. 5' RG-58/U cable. Terminates with pin-type plug.



Omnidirectional Indoor Antenna

For indoor or portable use. Plugs directly in to back of PRO-3A receiver. 22" overall. Decoupling skirt improves efficiency. Chrome-plated. 20-451, 1 1/2 lbs.

FRONT AND REAR PANEL CONTROLS

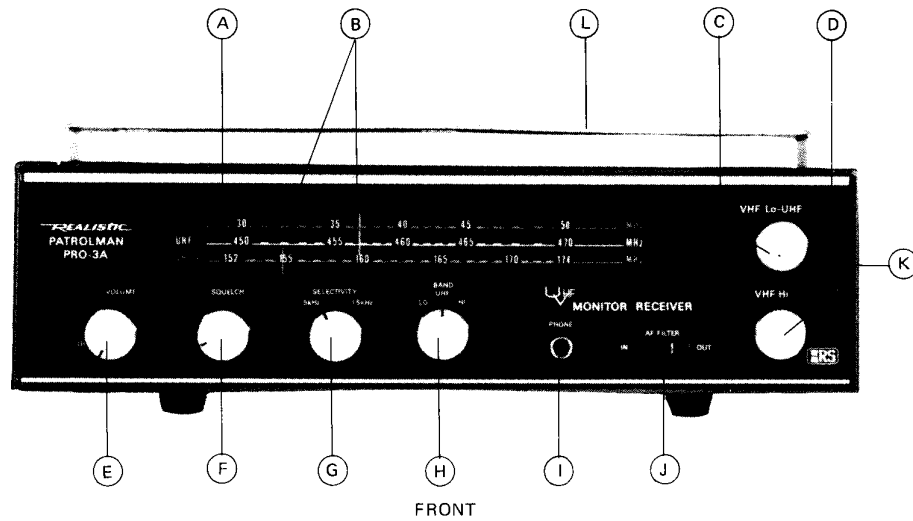

- A —Illuminated slide-rule dial.
- B —Separate dial pointers for 30-50 MHz/450-470 MHz and 152-174 MHz.
- C —Tuning knob for 30-50 MHz and 450-470 MHz band.
- D —Tuning knob for 152-174 MHz band.
- E —Power switch and audio volume control.
- F —Squelch eliminates no-signal noise.
- G —Selectivity switch chooses broad or sharp characteristic.
- H —Band switch.
- I —Low impedance audio Jack for phones or external speaker.
- J —Audio filter improves weak signal readability.
- K —Easily removed knurled mounting screws.
- L —Steel mounting bracket.

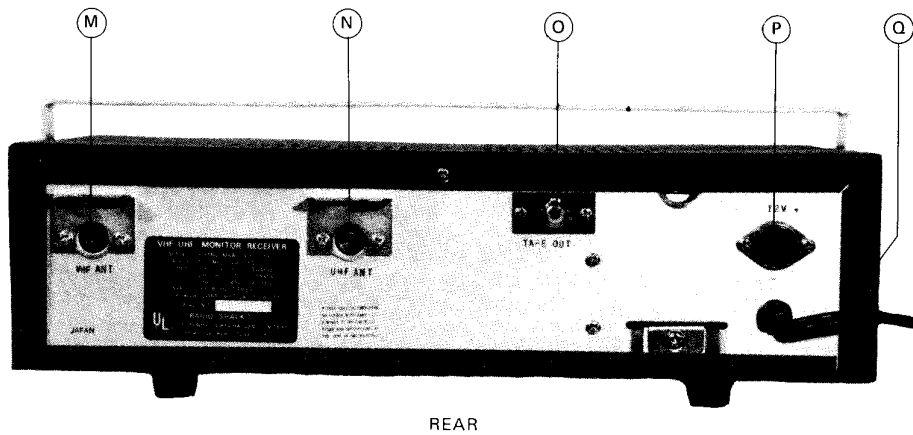

- M —Antenna connection for 30-50 MHz and 152-174 MHz band.
- N —Antenna connection for 450-470 MHz band.
- O —For P.A. or Tape Input.
- P —DC Power Connection Socket.
- Q —AC Power Cord.

FIG-1

ELECTRICAL INSPECTION

Set controls as follows: (Ref. FIG - 1, page 4)

1. Volume Control (E): Off position
2. Squelch (F): Minimum position (Counter clockwise)
3. Selectivity Switch (G): 15 KHz position
4. Band Switch (H): Low band position
5. Audio Filter (J): Out position
6. Antenna Jack (M,N): Connect antenna to jack
7. AC Power Cord (Q): Line cord to AC outlet (120 V)

Turn the Squelch Control to the minimum position. Turn the Volume Control to "ON" and a rushing sound will be heard in the speaker. Advancing the volume clockwise will increase the loudness of the noise. When the Squelch Control is slowly turned clockwise, a point will be reached where the background noise will disappear. This indicates normal squelch and also normal operation of the unit.

INSTALLATION

A good installation will make the most of the PRO-3A's capabilities. Loss of the tiny signal at the antenna is avoided by correct antenna adjustments and by installing a good quality foam coaxial cable. The antenna that you choose, and how you install it, will have a great effect on how well your unit will work.

- a. Base Station:
To install the PRO-3A in a base installation, simply connect the AC line cord into a 110-120V AC 60 Hz power source.
- b. An antenna, such as a ground-plane (Cat. No. 20-176) mounted as high above the ground as practical will greatly increase the signal strength. For proper input matching, a 50 ohm lead-in coaxial cable such as RG 8/u (Cat. No. 278-970) should be used. A Motorola type antenna adapter plug (Cat. No. 278-208, or equivalent to Cinch-Jones No. 13B or H.H. Smith No. 1200) will have to be installed on the receiver end of the cable in order to utilize the antenna connector located on the rear (back) panel of the unit.
- c. Mobile Station: CAUTION: BE AWARE OF THE BATTERY POLARITY.
For a vehicle with a 12V DC negative ground system, use the DC power cable supplied with the unit. Simply connect the cable into the cigarette lighter receptacle (Cat. No.274-331) or directly to the DC power supply source. The red lead is to be connected to the positive terminal of the power source and the black lead to the Negative.

IMPORTANT: If your car has been burning out headlamps and other bulbs at a rapid rate, have the voltage regulator checked for proper output. Excessive voltage (more than 16 volts) may cause serious damage to your Receiver.

- d. Safety and operating convenience are the primary factors to consider when mounting any piece of equipment in an automobile. Be sure that the Receiver controls may be easily reached by the operator. Also be sure that connecting cables do not interfere with the operation of the brake, accelerator, etc.

The Receiver may be mounted to the underside of the instrument panel or dashboard of a car, truck, boat, etc., by means of the special bracket that is supplied with the Receiver.

- e. Keep the following points in mind when installing your mobile antenna.
 1. Mount the antenna as high as possible, mounting in the center of the roof is the best possible location.
 2. Mount it rigidly, so it will remain vertical while in motion.
 3. Mount as far as possible from the engine compartment; mounting on the rear of the car is preferable to mounting in place of the AM antenna.

MOBILE NOISE SUPPRESSION

Noise:

This receiver is very sensitive, and will pick up signals that are extremely weak. With this extreme sensitivity, you will find that the receiver will amplify weak signals, along with any noise that may be present.

When operating a receiver in a vehicle, you will find that the vehicle generates noise, and this noise can become very objectionable. Mobile operation will not be as quiet as base station operation, but steps can be taken that will greatly improve the noise situation.

Electrical System:

Generally speaking, noise can be generated by any device or connection that carries electrical current. Any device that generates a spark should also be suspected. Bypass any suspected wire to ground with a high quality 1 μ f coaxial capacitor.

Probably the next most common source of noise is the generator, or alternator. This type of noise will sound like a musical whine, and will also vary with speed of the engine. Generator and alternator noise can usually be reduced by placing a coaxial-type capacitor from the armature terminal to the metal case.

Ignition System:

The ignition system is the most common source of noise. This noise can be identified by the fact that it varies with the engine speed. Ignition noise will sound like a series of "popping" sounds, while that engine is idling, and will speed up to a buzzing sounds as engine speed is increased.

There are a number of things that can be done for this type of noise.

1. Use radio suppression-type ignition wire, and resistor spark plugs.
2. Check high-tension lead etc. for leakage, cracks, etc. Replace any old wiring.
3. In extreme cases, kits may be purchased, that will completely shield all ignition wiring. This will provide maximum noise suppression.

Model PRO-3A Block Diagram

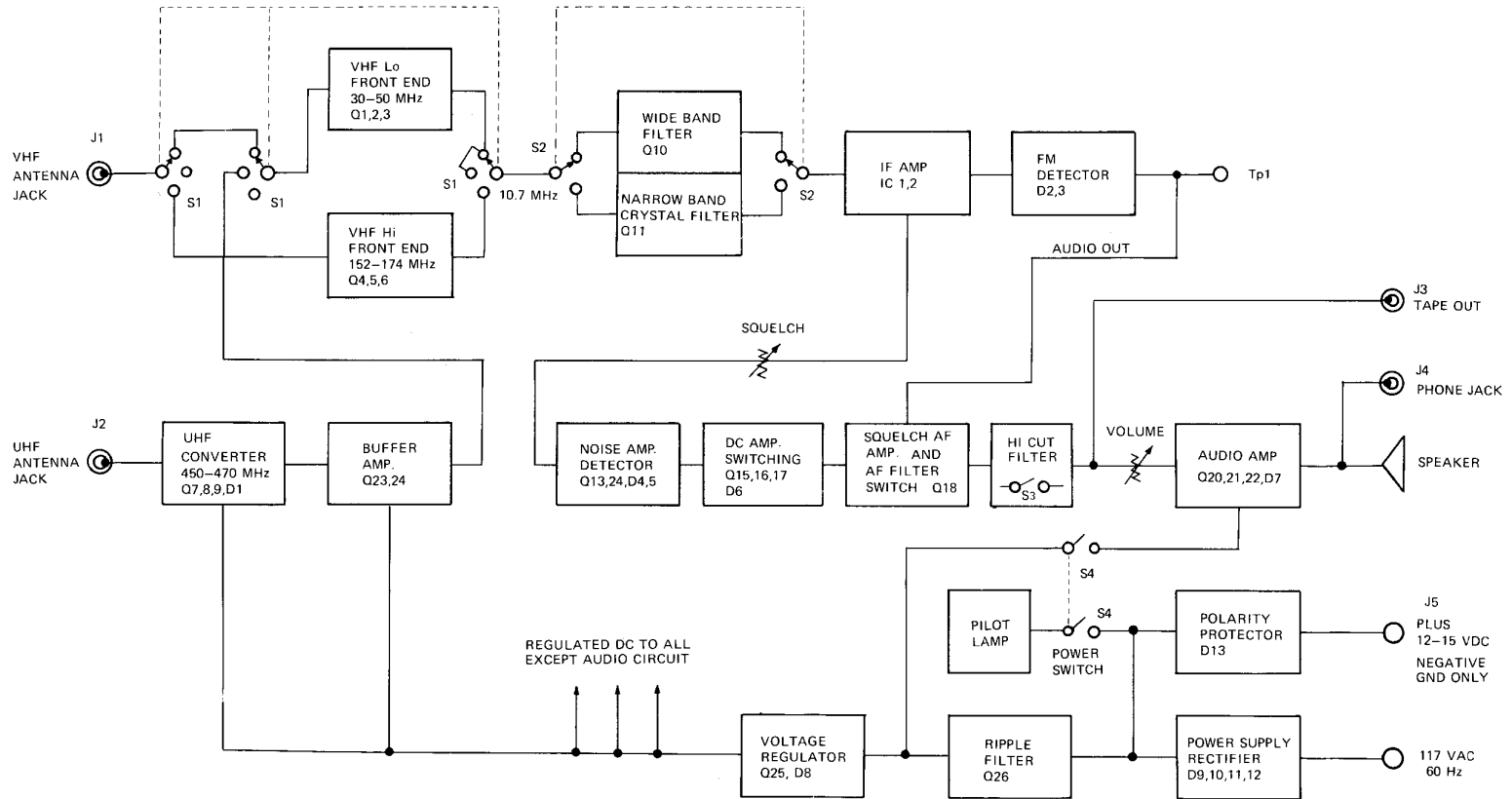

Model PRO-3A General Schematic

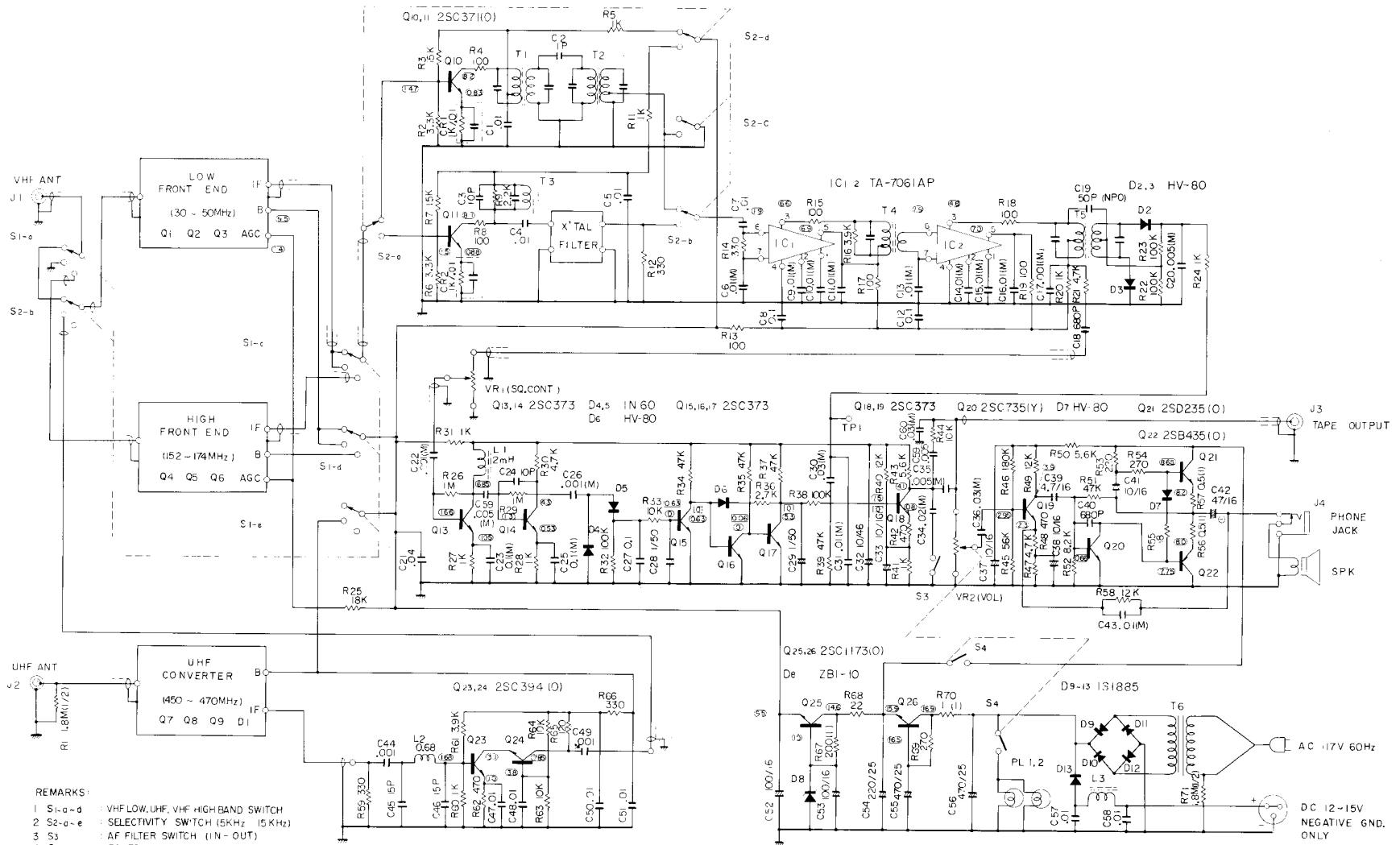

REMARKS:

- 1 S1-a-d : VHF LOW, UHF, VHF HIGH BAND SWITCH
- 2 S2-a-e : SELECTIVITY SWITCH (6KHz - 15KHz)
- 3 S3 : AF FILTER SWITCH (IN - OUT)
- 4 S4-a-b : POWER ON-OFF SWITCH
- 5 VR1 : SQUELCH CONTROL
- 6 VR2 : VOLUME CONTROL, W/PWR SWITCH
- 7 : RESISTANCE VALUES IN OHMS K=1000
- 8 : CAPACITANCE VALUES IN MF P=MMF
- 9 : DC VOLTAGE (MEASURED BY V.T.V.M.)
- 10 : DC VOLTAGE (SQUELCH CONTROL AT MAXIMUM CONDITION)
- 11 ALL VALUES AND RATING ARE SUBJECT TO CHANGE FOR IMPROVEMENT WITHOUT NOTICE.

Schematic of VHF LO front end. 30–50 MHz.

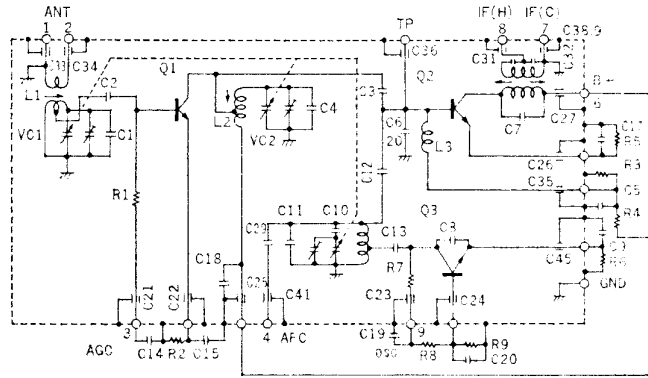

Schematic of VHF HI front end. 152–174 MHz.

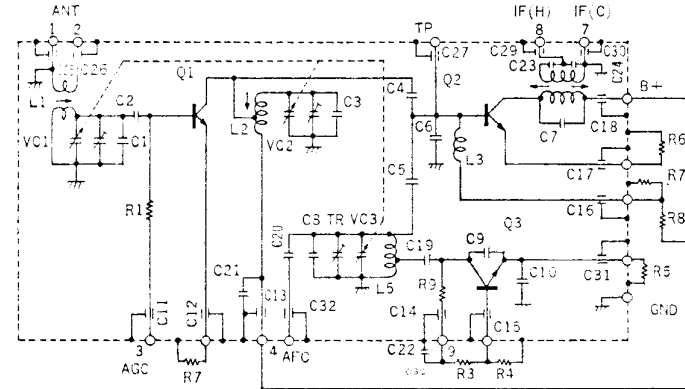

Schematic of UHF converter. 450–470 MHz.

