

10-CODES

Citizens band radio operators have largely adopted the 10-codes for standard questions and answers. Its use permits faster communication and better intelligibility in noisy areas. The following table lists some of the more common codes and their meanings.

Code	Meaning	Code	Meaning
10-1	Receiving poorly	10-10	Standing by
10-2	Receiving well	10-13	Advise road/weather conditions.
10-3	Stop Transmitting	10-20	What is your location?
10-4	OK	10-33	Emergency traffic
10-7	Out of Service	10-36	Correct time
10-8	In Service	10-41	Switch to Channel.
10-9	Repeat	10-62	Cannot copy you:

RADIO SHACK LIMITED WARRANTY

This product is warranted against defects for 90 days from date of purchase from Radio Shack company-owned stores and authorized Radio Shack franchisees and dealers. Within this period, we will repair it without charge for parts and labor. Simply **bring your Radio Shack sales slip** as proof of purchase date to any Radio Shack store. Warranty does not cover transportation costs. Nor does it cover a product subjected to misuse or accidental damage.

EXCEPT AS PROVIDED HEREIN, RADIO SHACK MAKES NO WARRANTIES, EXPRESS OR IMPLIED, INCLUDING WARRANTIES OF MERCHANTABILITY AND FITNESS FOR A PARTICULAR PURPOSE. Some states do not permit limitation or exclusion of implied warranties; therefore, the aforesaid limitation(s) or exclusion(s) may not apply to the purchaser.

This warranty gives you specific legal rights and you may also have other rights which vary from state to state.

We Service What We Sell

RADIO SHACK, A DIVISION OF TANDY CORPORATION

U.S.A.: FORT WORTH, TEXAS 76102
CANADA: BARRIE, ONTARIO L4M 4W5

TANDY CORPORATION

AUSTRALIA

280 316 VICTORIA ROAD
RYDALMEERE N S W 2116

BELGIUM

PARC INDUSTRIEL DE NANINNE
5140 NANINNE

U K

BILSTON ROAD, WEDNESBURY
WEST MIDLANDS WS10 7JN

C.B. 40-CHANNEL TRANSCEIVER

Misty

TRC-432

OWNER'S MANUAL

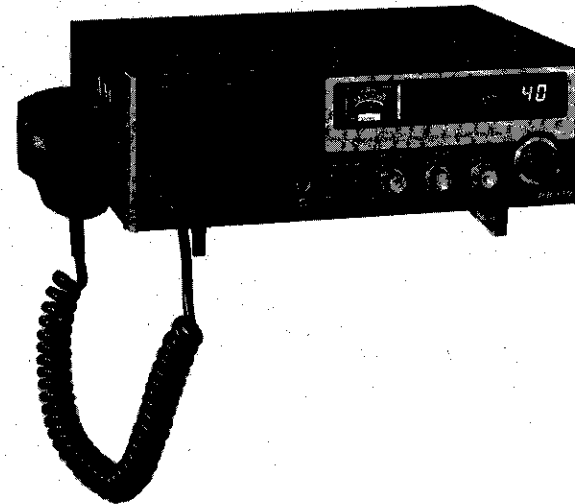

REALISTIC[®]

Your **REALISTIC** TRC-432 is a compact 2-way 40-channel radio designed for operation as a Class D CB Base Station. Though small in size, it's big in performance!

It is a quality piece of electronic equipment, skillfully constructed from the finest components. The circuitry is all solid-state, mounted on rugged printed circuit boards. It is designed for many years of reliable, trouble-free performance.

Your TRC-432 has a built-in 40-channel PLL synthesizer circuit. The Phase Lock Loop is a new technique for generating all the required frequencies with a single crystal. The result is much tighter frequency control and superior reliability.

FEATURES

- Phase Lock Loop circuitry for precise frequency control and stability over all 40 channels
- Crystal and ceramic filters for superior selectivity and freedom from adjacent channel interference
- Digital readout indicates channel selection in bright LED numerals
- Red Modulation Indicator helps you tell how fully your voice is modulating the Transmit carrier
- Hysteresis-type Squelch circuit automatically compensates for signal fading (eliminates signal "chopping" at precisely set Squelch levels)
- Dynamic plug-in Communications Microphone
- RF Output Power and Signal Strength Meter
- Emergency Switch lets you "jump" to Channel 9 or 19 — instantly!
- Bright green "ON THE AIR" indicator lights when transmitting
- Three-way CB-PA-MONitor switch
- Switchable Noise Blanker and Automatic Noise Limiter reduces noise interference.
- Two-way AC/DC Power Supply
- RF GAIN Control prevents overloading due to strong signals.
- Public Address capability — just add an optional PA speaker
- External Speaker Jack and Headphone Jack
- Coax-type Antenna Connector
- Utilizes 7 ICs, 24 transistors, 1 FETs and 41 diodes.

For your own protection, we urge you to record the Serial Number of this unit in the space provided. You'll find the Serial Number on the rear panel of the unit.

Serial Number

F.C.C. LICENSE (U.S.A.)

Before transmitting with your Transceiver, you must have an FCC Class D Citizens Radio Service License. If you don't have a license yet, you can fill out the Temporary Permit Form 555-B for a temporary license. Also, fill out and mail in FCC Form 505 CB License Application to:

Federal Communications Commission
P.O. Box 1010
Gettysburg, Penn. 17326

You must also read and know Part 95 of the FCC Rules and Regulations; they apply to the operation of a Class D Citizens Band unit. We've provided a copy of this regulation (along with the forms noted above).

NOTE: Units manufactured for sale in the U.S.A. cannot legally be used in Canada. Canadian models have been D.O.C. approved and carry a D.O.C. approval label with its approval number.

D.O.C. LICENSE (CANADA)

Before transmitting with your Transceiver, you must obtain a Department of Communications (D.O.C.) General Radio Service License. We've provided such an application form with your unit — complete the form and mail with the appropriate fee to the Radio Regulations Office nearest you.

D.O.C. Approval Number: _____

NOTE: Units manufactured for sale and use in Canada are not identical to units type accepted by the FCC. Canadian models have been approved by D.O.C. and are to be used only in Canada.

BEFORE YOU CALL FOR HELP...

Our repair centers receive many returned products which are actually **working perfectly**. Maybe the owner just didn't read the instructions, or overlooked something. Or perhaps the problem was a blown fuse that the owner could easily have replace.

So read this manual carefully and be sure **you** understand all the basic features of this CB — and the special ones, too! And before you assume your Transceiver needs repair, refer to the Service and Maintenance section of this manual, to see if the problem is something **you** can eliminate.

Enjoy your Realistic TRC-432!

SPECIFICATIONS

RECEIVER

Frequency Coverage:	All 40 CB Channels (Class D) 26.965 to 27.405 MHz
Sensitivity:	0.5 μ V or better for 10 dB S + N/N
Adjacent Channel Rejection:	66 dB (for 10 kHz), greater than 90 dB for 20 kHz
Intermediate Frequency:	1st IF = 10.695 MHz 2nd IF = 455 kHz
Audio Output:	6 watts (max.)
Frequency Response:	450 — 2500 Hz
Cross Modulation:	55 dB (or better)
Squelch:	Adjustable from 0.5 μ V to 1000 μ V

TRANSMITTER

Frequency Coverage:	All 40 CB Channels (Class D) 26.965 to 27.405 MHz
Power Output:	4 watts (maximum)
Emission:	8A3
Modulation Capabilities:	90 — 100%
Spurious Radiation:	Better than —70 dB
Frequency Tolerance:	Better than 0.002%
Antenna Impedance:	50 ohms
POWER REQUIREMENTS:	120 volts, 60 Hz AC 50 watts 12 — 16 volts DC, positive or negative ground.

PUBLIC ADDRESS

Output Power:	7 watts (maximum)
Output at 10% Distortion:	5.5 watts
Mic. Sensitivity for 4W Output Power (PA mode):	4 mV (at 1 kHz)
Frequency Response — 1/—2 dB:	450 — 2500 Hz
POWER REQUIREMENTS:	120 volts, 60 Hz AC 12 volts DC positive or negative ground

DIMENSIONS: 4-3/4" x 11-13/16" x 9-3/4" (H.W.D.)
(12.1 x 30 x 34.7 cm) (H.W.D.)

WEIGHT: 7 lbs. 1 oz. (3.2 kg)

CONTROLS AND THEIR FUNCTIONS

Front Panel

MICROPHONE (Mic)

High-quality dynamic microphone designed specifically for communications use. To transmit, press the button on the microphone. To Receive, release the button.

Microphone must be connected before you can receive any signals.

S/RF Meter — indicates relative strength of signal for either Receive or Transmit.

CB-PA-MON Switch
Selects desired mode of operation

MODULATION Indicator

Indicates relative modulation level while transmitting.

ON THE AIR

Lights up when transmitting

Emergency Switch

Instantly selects Emergency Channel 9 or Highway Information Channel 19.

LED Channel Indicator

Large LED display indicates channel number selected.

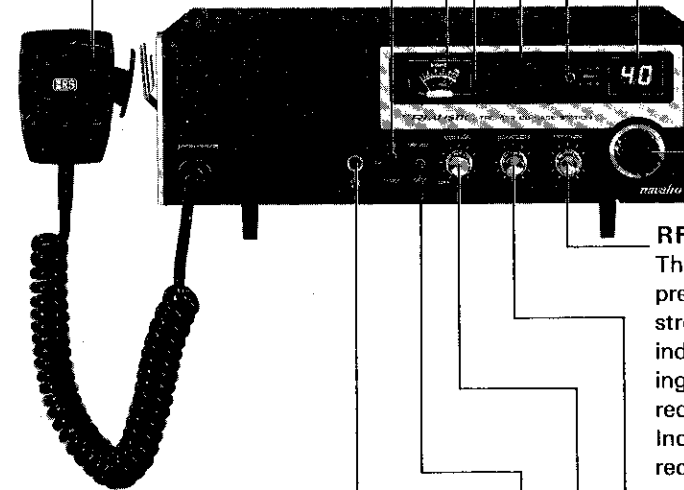

Channel Selector

Use to select any one of the 40 channels available.

RF GAIN Control

The RF GAIN control is used to prevent an overload when receiving strong signals. When Signal Meter indicates more than half scale (receiving strong local broadcasts), merely reduce RF GAIN control setting. Increase RF GAIN control when receiving weak or distant broadcasts.

SQUELCH Control

Lets you cut out annoying background noise when no station is being received. But, when properly set, it lets signals come through.

Headphone Jack

Plug Headphones (optional) into the Headphone Jack for private listening. Inserting the plug into this jack automatically disconnects the built-in speaker.

NB/ANL Switch

When in the "NB/ANL" position, it activates a "blinker-type" noise silencer and a series-type ANL circuit for receiving signals under noisy conditions.

VOLUME On/Off Switch

Turn clockwise to apply power to the Transceiver and then adjust for desired sound level.

Rear Panel

EXternal SPeaker Jack

You can connect an external Speaker (8 ohm type) to this jack for remote listening. Use a miniature-type phone plug such as Radio Shack Catalog Number 274-288.

AC Power Cord Receptacle

Attach AC Power Cord to this receptacle. Connect the cord to a source of 120 volts 60 Hz AC.

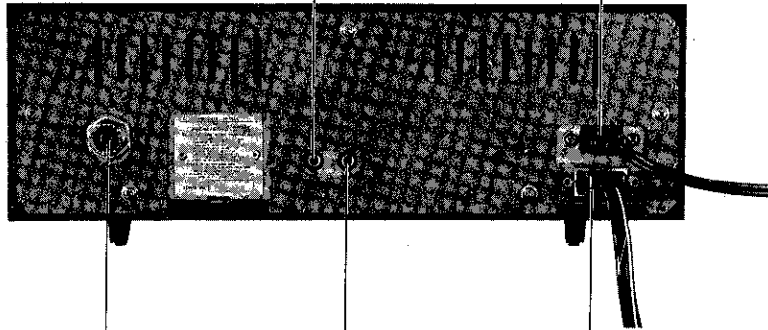

ANTenna Connector

Connect your CB Antenna to this. It accepts a PL-259 male-type coaxial connector.

DC Power Cord Receptacle

Attach DC Power Cord to this receptacle. Connect the cord to a source of 12 volts DC. Note that receptacle is asymmetrical to avoid wrong connection. If it won't fit, turn plug upside down and re-insert.

Public Address SPeaker

Connect an 8 ohm speaker (5 watts or more) for PA use.

SOME HINTS TO HELP YOU ENJOY YOUR CB

- Wait for a pause in transmission before asking for a Break.
- If you don't receive an answer after a second call to another station, sign off and allow others to use the channel - wait a while, ask for a break and try again.
- Do not Dead Key (hold transmitter button in).
- Assist callers with directions, road conditions or other requested information.
- Keep harassment off the air. This is unnecessary and causes problems for everyone, including you.
- Be courteous — treat others the way you wish to be treated.

SPECIAL INSTRUCTIONS FOR THE MIC CONNECTOR

Your Transceiver features a new locking type microphone connector. This insures that you won't accidentally pull out or loosen the plug connection (when extending the Mic cable while moving about).

To connect the Mic plug

You must press the small tab on the Mic plug and then press into the socket.

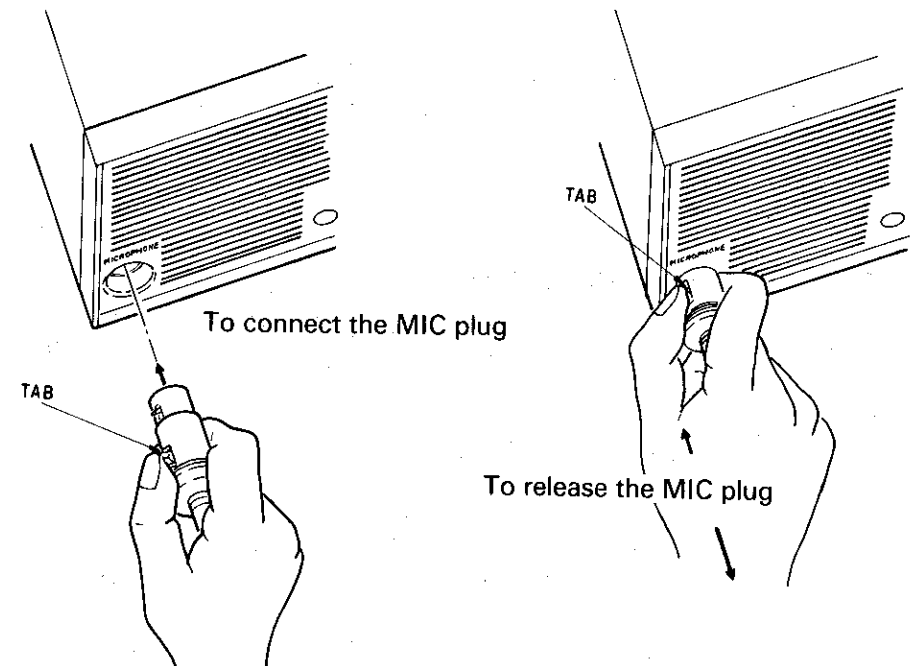

To release the Mic plug

You must press the small tab on the Mic plug, push plug in to release lock and then pull out.

NOTE: To hear receive sound, you must have the Mic connected.

CITIZENS BAND FREQUENCY CHART

CHANNEL	FREQUENCY	CHANNEL	FREQUENCY
1	26.965	21	27.215
2	26.975	22	27.225
3	26.985	23	27.255
4	27.005	24	27.235
5	27.015	25	27.245
6	27.025	26	27.265
7	27.035	27	27.275
8	27.055	28	27.285
9	27.065	29	27.295
10	27.075	30	27.305
11	27.085	31	27.315
12	27.105	32	27.325
13	27.115	33	27.335
14	27.125	34	27.345
15	27.135	35	27.355
16	27.155	36	27.365
17	27.165	37	27.375
18	27.175	38	27.385
19	27.185	39	27.395
20	27.205	40	27.405

MOUNTING MICROPHONE CLIP

Mount the Microphone Clip on the side of your Unit — on left or right side, in horizontal or vertical position — to suit your convenience. Refer to the illustration supplied.

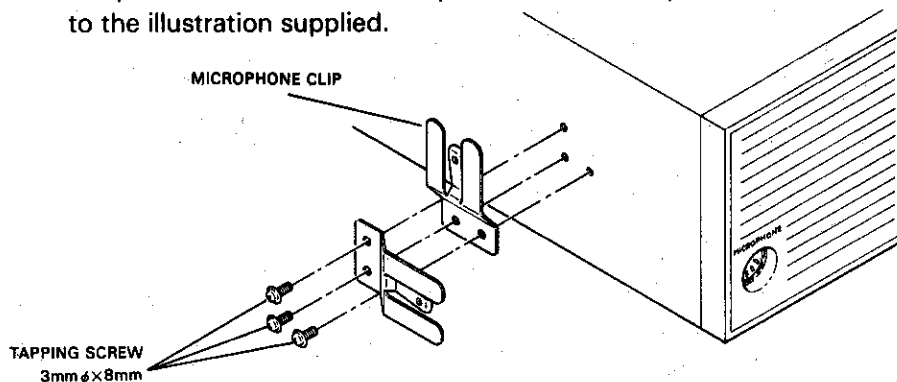

USING YOUR TRANSCEIVER

Do not Transmit without a suitable antenna or load connected to the ANTenna connector. For Installation, refer to that section.

TO RECEIVE

1. Check that 12 volts or 120 volts is applied to the Transceiver (through DC Power Cord or AC Line Cord).
When both AC and DC power sources are connected, unit operates on AC power.
2. Check that an antenna is attached.
3. Connect the Mic plug to Mic jack.
4. Set **CB-PA-MON** Switch to CB position.
5. Set Emergency Switch to the center position.
6. Turn **RF GAIN** control maximum clockwise.
7. Turn **SQUELCH** control maximum counterclockwise.
8. Turn power "on" by rotating **VOLUME** clockwise to click "on".
9. Set **Channel Selector** to the desired channel.
10. Adjust **VOLUME** for a suitable listening level.
11. Adjust **SQUELCH** to cut out annoying background noise when no signal is being received. To do this, set **Channel Selector** to a channel where no signals are present (or wait till signals cease on your channel). Then, rotate **SQUELCH** in a clockwise direction to the point where the background noise just stops. Now, when a signal is present, you will hear it, but will not be disturbed by noise on the channel in-between signals.

When properly set, **SQUELCH** will keep the receiver "dead" until a signal comes in on that channel. Do not set **SQUELCH** too high, or weak signals will not be able to "open" the Squelch circuit. To receive the very weak signals, it is best to leave **SQUELCH** set to the minimum position (maximum counterclockwise).

The **SQUELCH** circuit in your Transceiver is a special advanced development. It uses two extra transistors to accomplish a hysteresis action. The result is that when you set **SQUELCH** for a precise signal level, if that signal level fades (decreases or increases in strength), the Squelch circuit will follow this change. With conventional Squelch circuits often a signal which changes strength gets "chopped" by Squelch and you lose a portion of the message; with hysteresis Squelch you get it all.

TO TRANSMIT

1. Select the desired channel of operation.
2. Connect the Mic plug to Mic jack.
3. Press the push-to-talk button on the Microphone and hold it at an angle about 2–3" (5-7.5 cm) from your mouth and speak in a normal voice. ON THE AIR Indicator will light up green. MODULATION Indicator flickers as you talk into Mic.



4. To Receive, release the push-to-talk button.

Be sure the Mic plug is **firmly** connected to the jack: if the connector starts to loosen up, you may end up with squeal, feedback and many other unusual problems.

NOTE: Shouting into the Mic will not increase your power or signal. An internal circuit automatically sets the Mic signal for maximum modulation, so there is no need for loud speech — as a matter of fact, shouting may result in distortion (speech distortion going into the Mic).

Emergency Switch

In an emergency you don't want to spend time turning the Channel Selector until you reach the desired channel. So we've incorporated a special switch that puts you on Channel 9 or 19 instantly. Channel 9 has been set aside by the FCC for emergency communications only; Channel 19 is commonly used by truckers and motorists for conveying information on road and traffic conditions, etc.

Set the Emergency Switch to **9** (up) for Channel 9, and to **19** (down) for Channel 19. Move switch to center position to return to previously selected channel.

TO USE PUBLIC ADDRESS FUNCTION

Do not set the CB-PA-MON switch to PA unless an 8-ohm (5 watts or more) speaker is attached to the PA SP jack on the rear of the Transceiver.

1. Connect suitable 8 ohm speaker to the **PA SP** jack located on the rear.
2. Set the **CB-PA-MON** switch to the PA position.
3. Press and hold the push-to-talk button on the microphone and hold it at an angle about 2–3" (5–7.5 cm) from your mouth and speak in a normal voice.

4. Adjust **VOLUME** for a suitable public address level.

5. If you want to monitor CB incoming calls while you are using the PA function, set **CB-PA-MON** switch to MON position. This way you won't miss important CB calls (you'll hear them through the PA speaker).

Important: Always face the PA SPeaker away from the microphone and as far possible from the unit to prevent feedback (high-pitched howling sounds).

REMOTE SPEAKER OPERATION

An 8 ohm 3–10 watt speaker should be used for this function. Plug the speaker into the **EXT. SP.** jack at the rear of the Transceiver. When the external speaker is plugged in, the internal speaker is disconnected. You can now monitor all incoming signals through your remote speaker.

Summary of Operating Modes

Push-to-talk switch CB-PA-MON switch	EXT/PA SP Jack Connection							
	No Connection		EXT SP		PA SP		EXT & PA SP	
	Release	Hold	Release	Hold	Release	Hold	Release	Hold
CB	Internal Speaker (CB)	Transmit	EXT Speaker (CB)	Transmit	Internal Speaker (CB)	Transmit	EXT Speaker (CB)	Transmit
PA	No Output	No Output	No Output	No Output	No Output	PA Speaker (PA)	No Output	PA Speaker (PA)
MON	No Output	No Transmit	No Output	No Transmit	PA Speaker (CB)	PA Speaker (PA)	PA Speaker (CB)	PA Speaker (PA)

Note: When CB-PA-MON switch is in PA position, the LED display will show "OFF". But when CB-PA-MON switch is in MON position, the LED display will indicate the channel number selected.

BASE STATION INSTALLATION

Your Transceiver can operate directly from the AC line. Connect one end of the AC plug to the AC Power Cord Receptacle, plug the other end to a convenient 120 volt outlet. Now all you need is an Antenna and you're "On the Air". Also, you can use an external or PA Speaker; read the rest of this manual for details about this and other functions.

Never leave AC cord plugged into the AC power if other end is not connected to your TRC-432 (the unconnected end has dangerous AC voltage available at it).

MOBILE INSTALLATION

You can install this Transceiver in any location where 12 volts DC power is available. It can be connected to either positive or negative ground systems. Just be sure you connect the Black and White wire to the (+) terminal and the Black wire to the (-) terminal.

With Negative Ground

Connect the Black and White wire (with in-line fuse holder) to the ACCessory terminal on the fuse block or ignition switch of your vehicle. Make a good mechanical and electrical connection to the frame of the vehicle for the Black (negative) wire.

With Positive Ground

Connect the Black wire to the ACCessory terminal of the fuse block or ignition switch. Connect the Black and White wire (with in-line fuse holder) to the frame of the vehicle.

You can use an auto accessory plug (Radio Shack Catalog Number 274-331) to connect your Transceiver to the vehicle's cigarette lighter plug. However, it is better to connect the DC power cord directly to the accessory terminal of the ignition switch. This will prevent unauthorized use of the Transceiver, and will also prevent you from leaving it on unintentionally.

Connect the Antenna system to the **ANTenna** coax connector. If you are using an external or PA speaker, connect it to the **EXT SP** or **PA SP** jack.

ANTENNA SYSTEM

The antenna system includes the transmission line, and it is very important that you use the correct type of transmission line. The transmission line should be of the coaxial type and should have an impedance equal to the antenna impedance.

Since your transceiver is designed to operate most efficiently into a 50 ohm load, it is best to use a type of coaxial cable with an impedance of 50 ohms. We suggest type RG-58/U for short lengths and RG-8/U for long lengths — over 100' (30 m).

Generally speaking, you should keep the length of the transmission line to a minimum. Remember that transmission line losses increase with frequency. Use foam insulation coax for best results.

The above discussion is as important for reception as it is for transmission. If a mismatch exists between the antenna and the receiver, the excellent sensitivity and signal-to-noise ratio of the receiver circuitry will be defeated.

BASE STATION ANTENNAS

There are three basic types of base antennas (shown below).

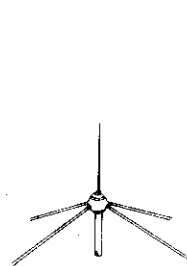

GROUND PLANE

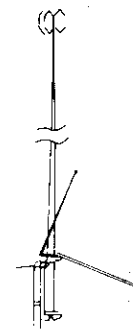

COAXIAL

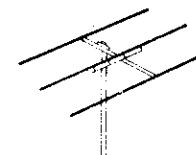

BEAM

BASE STATION ANTENNAS

- A. The vertical ground plane antenna is the most popular fixed station antenna. It is omni-directional and provides good performance for contacting other fixed and mobile stations. For medium-long range communications. We suggest Radio Shack's 21-901.

Remove (4) screws ★ from the Cabinet bottom.

Use the screws (★) just removed to mount the Brackets (A); tighten securely.

Mount Brackets (B) to the dashboard.

Fit the indexing tabs of brackets (B) into the appropriate slot on Brackets (A) to slant the unit as desired.

Secure in position with the Bracket Knobs.

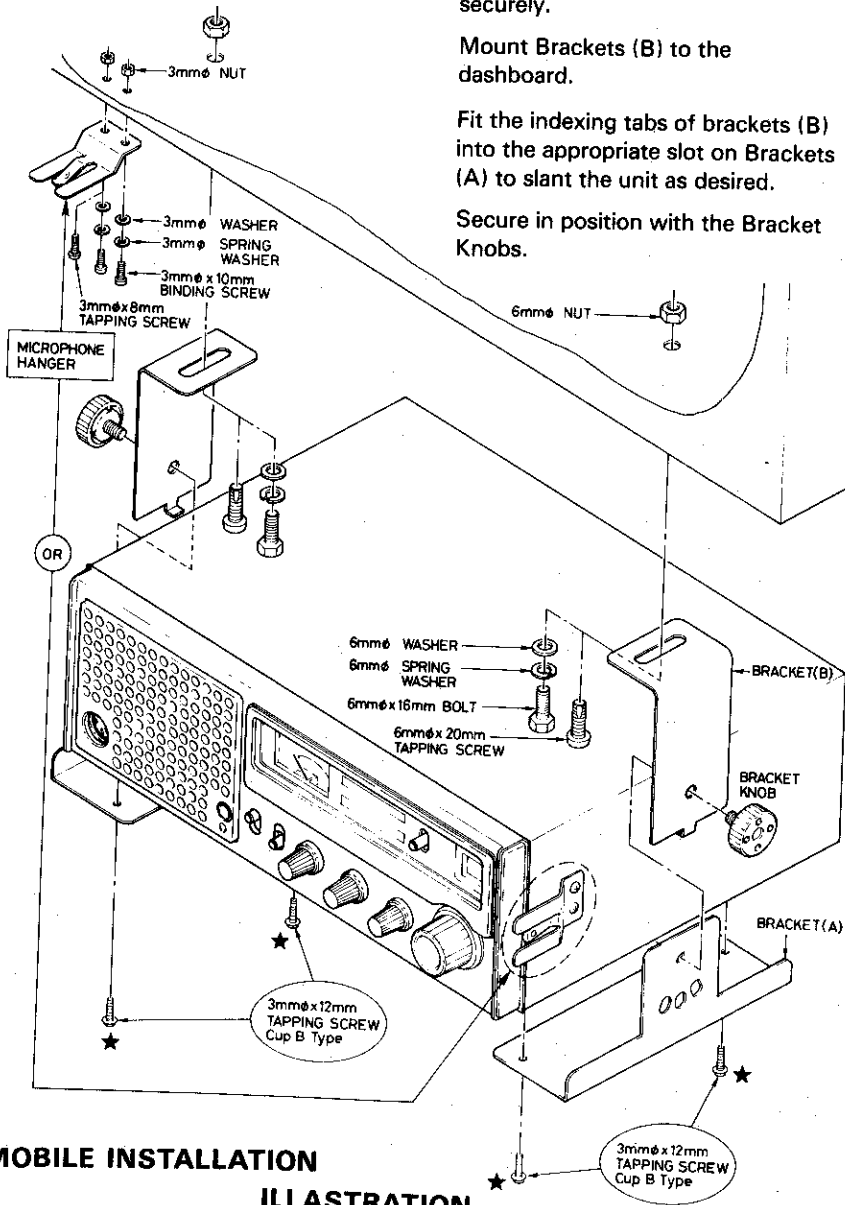

MOBILE INSTALLATION ILLUSTRATION

Safety and convenience are the primary considerations for mounting any piece of mobile equipment. All controls must be readily available to the operator without interfering with the movements necessary for safe

operation of the vehicle. Be sure all cables are clear of the brake, clutch and accelerator. Also, thought must be given to the convenience and comfort of passengers (for example will they have adequate leg room?).

Another extremely important requirement is the ease of installation and removal (for service and maintenance). Mount the Transceiver so it can be slipped in and out very easily.

The most common mounting position for a Transceiver is under the dashboard directly over the driveshaft hump. Do not mount the Transceiver in the path of the heater or airconditioning air stream.

When you have determined the best location for mounting, temporarily attach the Mounting Brackets to the unit as illustrated; use the Unit with the Brackets as a template to mark mounting holes. Take care when you drill holes that you do not drill into wiring, trim or other accessories. Detach the Brackets (B) and mount in position with bolts, lockwashers and nuts or self-threading screws. Secure Bracket assembly as shown.

TO GET THE MOST OUT OF YOUR TRANSCEIVER

We've provided a few extra features that will enhance your operation.

The **S/RF Meter** gives you a relative indication of RF output power when you are transmitting (upper scale — any reading in the red area means you have full legal output). When receiving, the meter shows the relative strength of the incoming signal (lower scale in "S" units).

The **NB/ANL** switch adds the Noise Blanker and Automatic Noise Limiter circuits. These help reduce or eliminate low-level impulse-type external noise and static-type noise (caused by automobile engines or ignition systems).

The **MODULATION Indicator** will light up when you transmit. Degree of brilliance will vary with your voice level. It will be at maximum brilliance when you achieve 100% modulation.

The **RF Gain Control** lets you adjust the sensitivity of your Transceiver on receive. When the S/RF meter indicates more than half scale (strong signal received), reduce **RF GAIN** control setting. Increase when receiving weak signals.

A Remote or External Speaker connected to the **EXT. SP.** jack on the back will give you added versatility. When you plug a miniature jack into this connector, the internal speaker will be disconnected. Radio Shack sells a number of fine speakers for Remote/Extension CB use.

Connect Headphones to the Headphone Jack and enjoy the advantage of avoiding annoying background noise when trying to listen to weak or distant stations. When you plug Headphones into this jack, it automatically disconnects the internal Speaker.

- B. The coaxial antenna is a high-efficiency radiator with omni-directional characteristics. It performs as well in most applications as the ground plane. For medium-long range communications. Try 21-902, 21-1133 or 21-964.
- C. The directional beam antenna provides maximum gain and maximum directivity. The directivity can be a disadvantage unless a rotor is used. Since a beam antenna is directional, it greatly reduces noise and interference from all other directions. For long range communications.

The antenna system should be adequately grounded.

Always use a static discharge unit for your antenna system.

For maximum efficiency, we strongly recommend using an SWR meter to aid in the proper matching of your antenna and Transceiver.

Your Radio Shack store carries a complete line of base station CB antennas and accessories.

For more information, we recommended that you obtain a copy of *CB RADIO FOR TRUCKS, CARS AND BOATS*, at your Radio Shack store.

NOISE

You may experience some interference from automobile ignition systems, high voltage power lines, fluorescent lights, or electrical motors. There are some things you can do about it and here are few pointers to get you started:

- Provide a good ground for your Transceiver and/or antenna.
- Assure good shielding connection in the antenna coax cable—check connectors and cable; repair if necessary.
- Check routing of antenna cable — move away from noise-generating sources.
- Try relocating your Transceiver or antenna (away from sources of noise).

Note: Your antenna should not be mounted near a power line or power distribution transformer.

- In some cases, an AC line interference filter added to the AC input to your Transceiver can help. If a particular appliance or motor seems to be the major cause of noise, try to have that noise problem reduced or eliminated at the appliance or motor. You'll find a number of useful accessories (including AC line interference filters, cables, connectors...) available at your Radio Shack store.

In Mobile operation, your vehicle or boat can be the cause of much noise interference. Since the receiver section of your transceiver is very sensitive, it will pick up even the smallest noise signals and amplify them. Any noise that you hear in the Transceiver is almost totally from external sources. The receiver itself is exceptionally quiet.

If the noise is continuous and fairly loud, it cannot be totally eliminated by the Automatic Noise Limiter (ANL) and Noise Blanker (NB) Circuit. You must solve the problem at its source.

To find out if the noise is from your ignition system, try this simple test. Turn off your ignition switch and set it to ACC (accessories). This turns off the ignition, but supplies power to the Transceiver. Most of the noise will probably disappear, indicating that the source of noise is your vehicle's ignition or other electrical systems.

Ignition System

Ignition-type noise can be identified by the fact that it varies with the speed of the engine. It consists of a series of popping sounds. There are a number of things that can be done to reduce this type of noise:

1. Use only the "radio suppression type" high voltage ignition wire. Most new cars come already equipped with this type of wire.
2. Inspect the high voltage ignition wire and all connections made with this wire. Old ignition wire may develop leakage, resulting in hash sound (a hash, hissing sound).
3. If noise still persists, replace the spark plugs with spark plugs that have suppressor resistors built-in. Be sure to use the correct type for your vehicle.

Other sources of noise are: generator/alternator, regulator, gauges and static discharge. Most of these types of noise can be effectively reduced or eliminated by using bypass capacitors at the various output voltage points. We suggest you check your Radio Shack store for a selection of noise reduction accessories.

SERVICE AND MAINTENANCE

Your Transceiver has been built in accordance with Radio Shack's exacting quality control standards. However, it should be treated with reasonable care accorded any electronic equipment. Avoid exposing it to severe shock, dirt or moisture.

If you run into problems with the unit, we recommend you check the following:

1. If trouble is experienced with receiving.
 - Check the **VOLUME** On/Off switch setting.
 - Be sure **SQUELCH** is adjusted properly. Is it over-squelched?
 - Check if the unit is switched to an operating channel.
 - Check if the Mic is securely connected.
 - Check for good antenna connection.
 2. If trouble is experienced with transmitting.
 - Check if the transmission line is securely connected to the ANTenna Connector.
 - Check if the antenna is fully extended for proper operation.
 - Are all transmission line connections secure and free of corrosion?
 - Make sure you are fully pressing the Push-to-Talk Button on the Mic.
 - Be sure Mic connector is firmly pressed into its jack.
 - Check setting of PA-CB-MON switch.
 3. If the Transceiver is completely inoperative.
 - Check that the AC Line Cord is connected.
 - Check DC power cord and in line fuse.
- Replace only with an identical 2 amp fuse.

If these checks don't solve the trouble, do **NOT** attempt repairs or adjustments yourself. The unit should be serviced only by a qualified radio technician. Whenever possible, return the unit to the store from which it was purchased.

WARNING

Do not open up the Transceiver to make any internal adjustments. Any internal adjustments can be made only by (or under the direct supervision of) a person holding an FCC 1st or 2nd Class Radio Operator's License.

Internal adjustments and/or modifications can lead to illegal operation as defined by FCC Rules and Regulations, Part 95. Such illegal operation can lead to very serious consequences.

TO BE SAFE AND SURE:

1. You should never open up the case of your Transceiver.
2. Never change or replace anything in your Transceiver.

TYPICAL APPLICATIONS FOR CB

Personal and Family

With a base station at home and a mobile set in the car, you can keep in touch while driving to work, to the store or to other social activities.

Let your family know when you're tied up in traffic, or find out if you should stop by the market on your way home.

Contact friends and neighbors — find out "what's happening" or plan a get-together. You can even meet new friends this way.

Ever have car trouble or run out of gas on the highway? What an assurance it is to be able to radio for assistance!

Camping, hunting or other sports are made more fun with CB. Locate a buddy or find out "What's cooking back at camp".

Use the PA amplifier for calling companions on outings, at truck stops, etc.

Business Uses:

Call your office or coordinate field employee activities.

Sales and Service people save valuable time and cut down missing contacts and appointments.

Doctors and Nurses can call their office or hospital to check on important calls or a particular patient.

With Security Policemen 2-way radio is more than a convenience, it's a must for both safety and efficiency.

Truckdrivers and Deliverymen learn road and traffic conditions and obtain assistance in locating destinations. CB is also a lot of company on these "long hauls".

In Construction Crews, CB quickly pays for itself when you're calling for additional materials or coordinating the activities of various work crews.

SCHEMATIC DIAGRAM

