

**REALISTIC<sup>®</sup>**

# Service Manual

21-1562



**TRC-449**

**CB TRANSCEIVER**

**Catalog Number: 21-1562**



CUSTOM MANUFACTURED FOR RADIO SHACK  A DIVISION OF TANDY CORPORATION

## TABLE OF CONTENTS

1. SPECIFICATIONS.....	3 ~ 5
2. DISASSEMBLY INSTRUCTIONS.....	6
3. BLOCK DIAGRAM .....	7
4. ALIGNMENT INSTRUCTIONS.....	8 ~ 16
5. TROUBLESHOOTING HINTS.....	17 ~ 18
6. PLL CIRCUIT TROUBLESHOOTING HINTS.....	19
7. IC. TRANSISTOR & DIODE LEAD IDENTIFICATIONS....	20
8. IC & COMPOUND PARTS INTERNAL DIAGRAMS .....	21
9. CHANNEL SWITCH P.C. BOARD (FLEXIBLE).....	22
10. NOISE BLANKER P.C. BOARD .....	22
11. SPEAKER JACK P.C. BOARD (TOP & BOTTOM).....	22
12. MAIN P.C. BOARD (TOP VIEW).....	23
13. MAIN P.C. BOARD (BOTTOM VIEW).....	24
14. ADDITIONAL PARTS ON THE BOTTOM.....	25
15. WIRING DIAGRAM.....	26
16. WIRING DIAGRAM.....	27
17. WIRING DIAGRAM.....	28
18. ELECTRICAL PARTS LIST .....	29 ~ 42
19. MECHANICAL PARTS LIST .....	43 ~ 45
20. SCHEMATIC DIAGRAM .....	(SEPARATE SHEET)
21. EXPLODED VIEW .....	(SEPARATE SHEET)

# 1. SPECIFICATIONS

## GENERAL :

Channels	: 40 Channels for AM, Upper Side Band and Lower Side Band, utilizing Digital Circuitry
Frequency Range	: 26.965 MHz to 27.405 MHz
Frequency Control	: Digital (Phase Lock Loop) Synthesizer
Frequency Accuracy	: $\pm 100$ Hz
Operating Temperature Range	: $-20^{\circ}\text{C}$ to $+50^{\circ}\text{C}$
Power Requirements	: 13.8V DC (12-16 volts DC, negative or positive ground)
Antenna	: 52 ohm (Coaxial connector)
Microphone	: 600 ohm Dynamic Type
Speaker	: 8 ohm, 3 Watt
Size	: 2-3/8" x 7-7/8" x 10-1/2" (HWD) (6 x 20 x 26.6 cm [HWD] )
Weight	: 6 lbs. (approx.) (2.65 kg)
Accessories	: DC Cord with in-line Fuse, Microphone and Microphone Hanger and Mounting Brackets

## MEASUREMENT CONDITION:

Power Source	: 13.8V DC
Antenna Impedance	: 50 ohm
Test Temperature	: $25^{\circ}\text{C}$
AM Modulation Frequency	: 1 kHz
SSB Modulation Frequency, Transmit	: Two tone: 500 Hz and 2400 Hz Single tone: 1 kHz
Mean Signal Input Level	: $1000\ \mu\text{V}$
Reference Audio Output Power	: 0.5 W
Reference AM Modulation Percentage	: 1 kHz 30%
Audio Frequency, SSB Receive	: 1 kHz
Audio Output Load	: 8 ohms resistive
Measuring Channel	: 19

<b>RECEIVER : (ANL &amp; Noise Blanker Switch OFF)</b>		<b>UNIT</b>	<b>NOMINAL</b>	<b>LIMIT</b>
Max. Sensitivity	: AM	$\mu\text{V}$	0.5	1
	: SSB	$\mu\text{V}$	0.25	0.5
Sensitivity for 10 dB S/N	: AM	$\mu\text{V}$	0.5	1
	: SSB	$\mu\text{V}$	0.25	0.5
AGC Figure of Merit 50 mV for 10 dB Change in Audio Output	: AM	dB	90	80
	: SSB	dB	90	80
Overload AGC Characteristics from 10 mV to 100 mV	: AM	dB	$\pm 3$	$\pm 5$
	: SSB	dB	$\pm 3$	$\pm 5$
<b>Overall Audio Fidelity at 6 dB Down</b>				
Upper Frequency	: AM	Hz	2100	1750 ~ 2500
	: SSB	Hz	3500	2500 ~ 5000
Lower Frequency	: AM	Hz	450	300 ~ 650
	: SSB	Hz	450	300 ~ 650
Cross Modulation, RS Standard	: AM	dB	60	50
Adjacent Channel Selectivity (10 kHz)	: AM	dB	65	54
	: SSB	dB	65	54
Maximum Audio Output Power	: AM	W	4	3
	: SSB	W	4	3
Audio Output Power at 10% THD	: AM	W	3	2.5
	: SSB	W	3	2.5
<b>THD at 500 mW Audio Output</b>				
AM: 1 mV Input, 30% modulation	: AM	%	3	6
	: AM	%	5	12
SSB: 1 mV Input 1 kHz Single tone	: SSB	%	3	6
<b>RF Gain Control Range at Max. Sensitivity Level</b>				
	: AM	dB	40	30 ~ 50
	: SSB	dB	40	30 ~ 50
S/N Ratio at Input 1 mV	: AM	dB	50	40
	: SSB	dB	50	40
Squelch Sensitivity at Threshold	: AM	$\mu\text{V}$	0.5	1
	: SSB	$\mu\text{V}$	0.25	0.5
S Meter Sensitivity at "S-9" (No Modulation AM)	: AM	$\mu\text{V}$	100	25 ~ 400
	: SSB	$\mu\text{V}$	100	25 ~ 400
Image Rejection Ratio. $f_o + (2 \times 7.8 \text{ MHz})$	: AM	dB	80	70
	: SSB	dB	80	70
1/2 IF Rejection Ratio. $f_o + 7.8 \text{ MHz}/2$	: AM	dB	90	80
	: SSB	dB	90	80
IF Rejection Ratio. 7.8 MHz	: AM	dB	85	75
	: SSB	dB	85	75
Oscillator Dropout Voltage	: AM	V	9	11
	: SSB	V	9	11
Clarifier Range	: AM	kHz	$\pm 1.25$	$\pm 0.6 \sim \pm 2.5$
	: SSB	kHz	$\pm 1.25$	$\pm 0.6 \sim \pm 2.5$
Spurious Rejection Ratio	In band	: AM	dB	65
		: SSB	dB	65
	Out of Band	: AM	dB	60
		: SSB	dB	60

		UNITS	NOMINAL	LIMIT
Battery Drain at No Signal	: AM	mA	550	1000
	SSB	mA	550	1000
Battery Drain at Maximum Output Power	: AM	mA	1500	2000
	SSB	mA	1500	2000

## PUBLIC ADDRESS:

Microphone Sensitivity for 3W Output Power at 1 kHz		mV	1	3
Maximum Output Power		W	4	3

## TRANSMITTER:

Frequency Tolerance at 25° C (5 Minutes after switch on)	: AM	%	±0.0005	±0.003
	SSB	%	±0.0005	±0.003
Carrier Power at No Modulation	: AM	W	3.8	4.0
PEP Power, Two Tone	: SSB	W PEP	12	12.0
Modulation Distortion at 1 kHz, 80% Modulation	: AM	%	3	10
Spurious Harmonic Emission	: AM	dB	-65	-60
	SSB	dB	-65	-60
Carrier Suppression	: SSB	dB	-55	-40
Unwanted Sideband Suppression at 25 kHz	: SSB	dB	-55	-40
Modulation Frequency Response (1 kHz, 0 dB reference)				
Lower at 450 Hz, EIA	: AM	dB	-6	-10
	SSB	dB	-6	-14
Upper at 2.5 kHz, EIA	: AM	dB	-6	-10
	SSB	dB	-6	-10
Carrier Power Uniformity, Ch to Ch at No Modulation	: AM	W	0.3	0.4
Mic Input Level Uniformity, Ch to Ch for 4 watts Output .25 kHz Single tone - SSB		dB	2	3
Mic Input Level Uniformity, LSB to USB for 4 watts Output, 1.5 kHz Single Tone		dB	1	3
Microphone Sensitivity				
AM: For 50% Modulation	: AM	mV	1.0	2.0
SSB: For 4 watts PEP	: SSB	mV	1.0	2.0
AMC Range				
AM: 50 ~ 100% Modulation	: AM	dB	46	40
SSB: 10 ~ 13.2 watts PEP	SSB	dB	46	40
Battery Drain at No Modulation	: AM	mA	2200	2600
	SSB	mA	1000	1500
Battery Drain				
AM: 80% Modulation	: AM	mA	2600	3000
SSB: 10 watts PEP, Two tone	SSB	mA	2000	2700

### Note;

Nominal Specs represent the design specs; all units should be able to approximate these, some will exceed and some may drop slightly below these specs.

Limit Specs represent the absolute worst condition which still might be considered acceptable, in no case should a unit perform to less than within any Limit Spec.

## 2. DISASSEMBLY INSTRUCTIONS

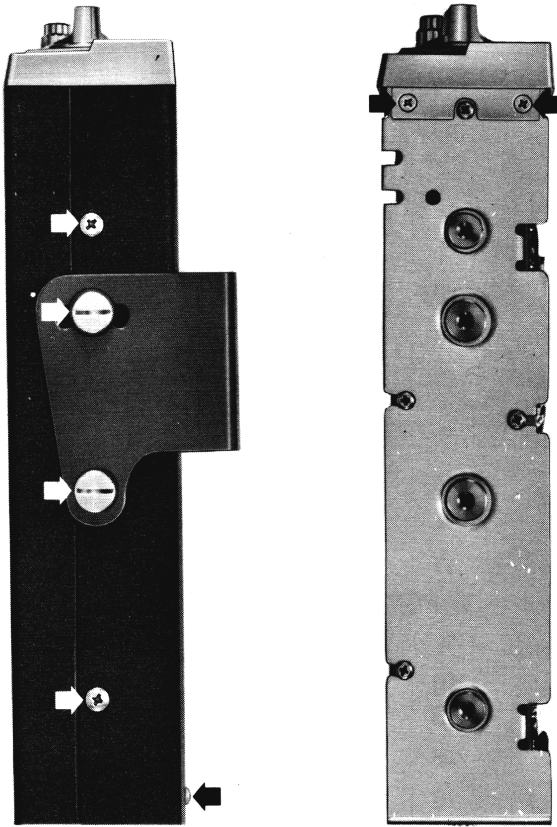

Figure 1

Figure 2

1. To remove Top & Bottom Cover: (Figure 1)  
Remove 4 screws from each side and a screw from top. Slide the top toward the rear of the chassis and remove.

2. To remove Front Panel: (Figure 2)  
Remove 2 screws from each side.

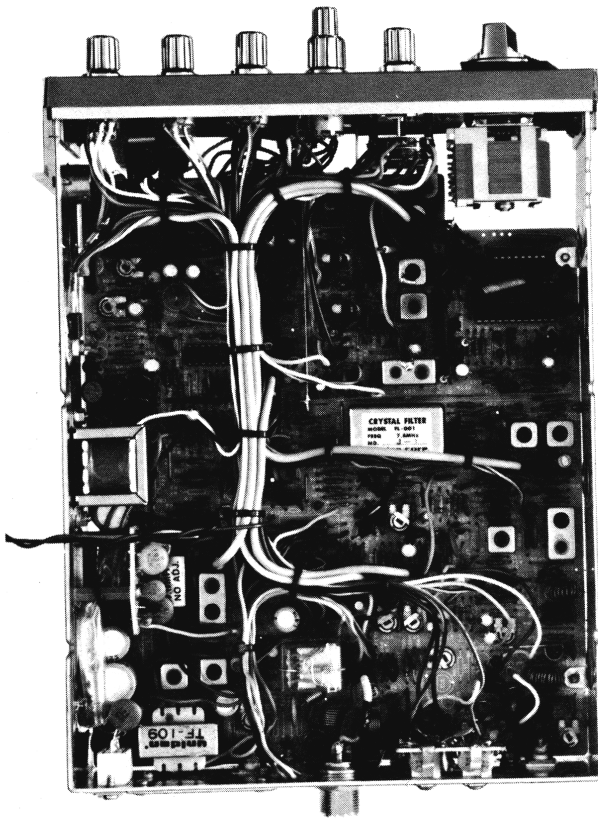

Figure 3

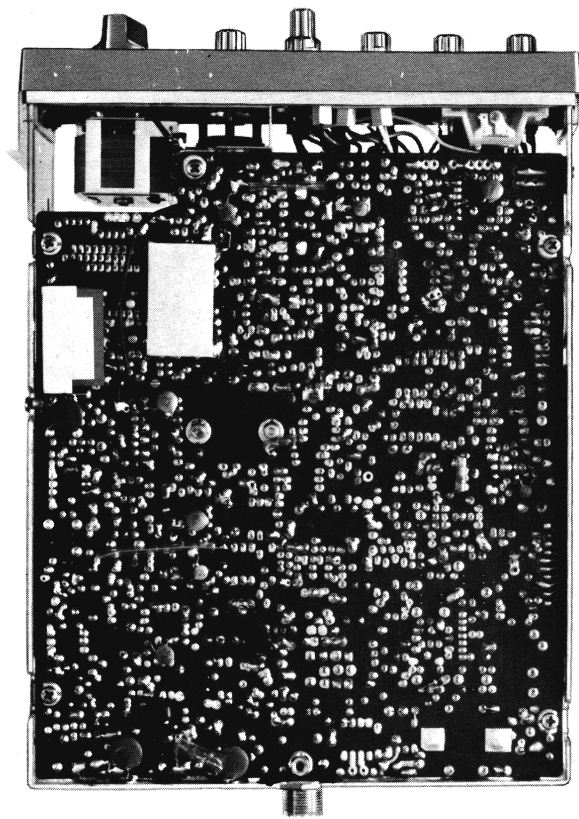
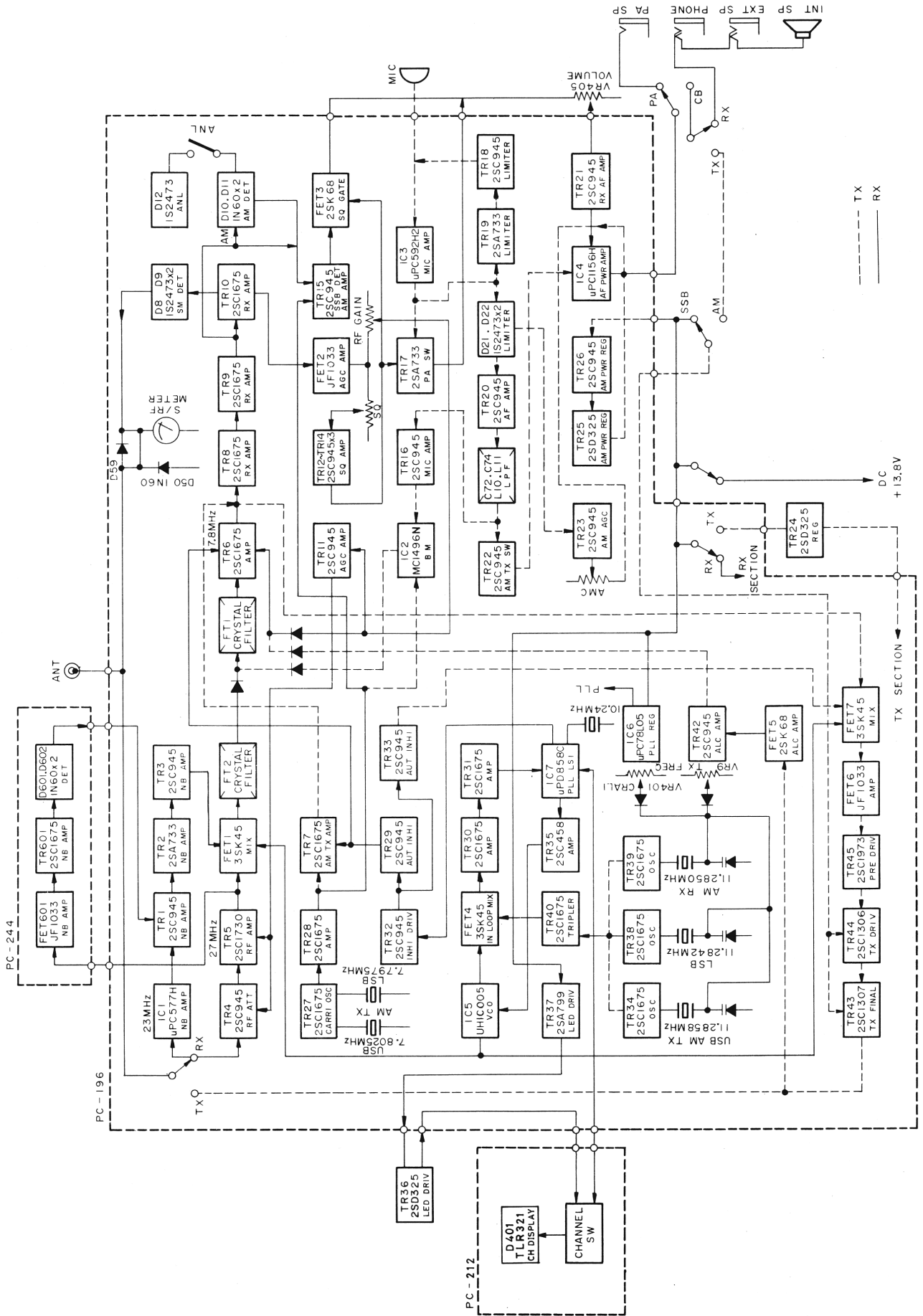

Figure 4

# 3. BLOCK DIAGRAM



# 4. ALIGNMENT INSTRUCTIONS

## CHASSIS LAYOUT-ALIGNMENT POINTS

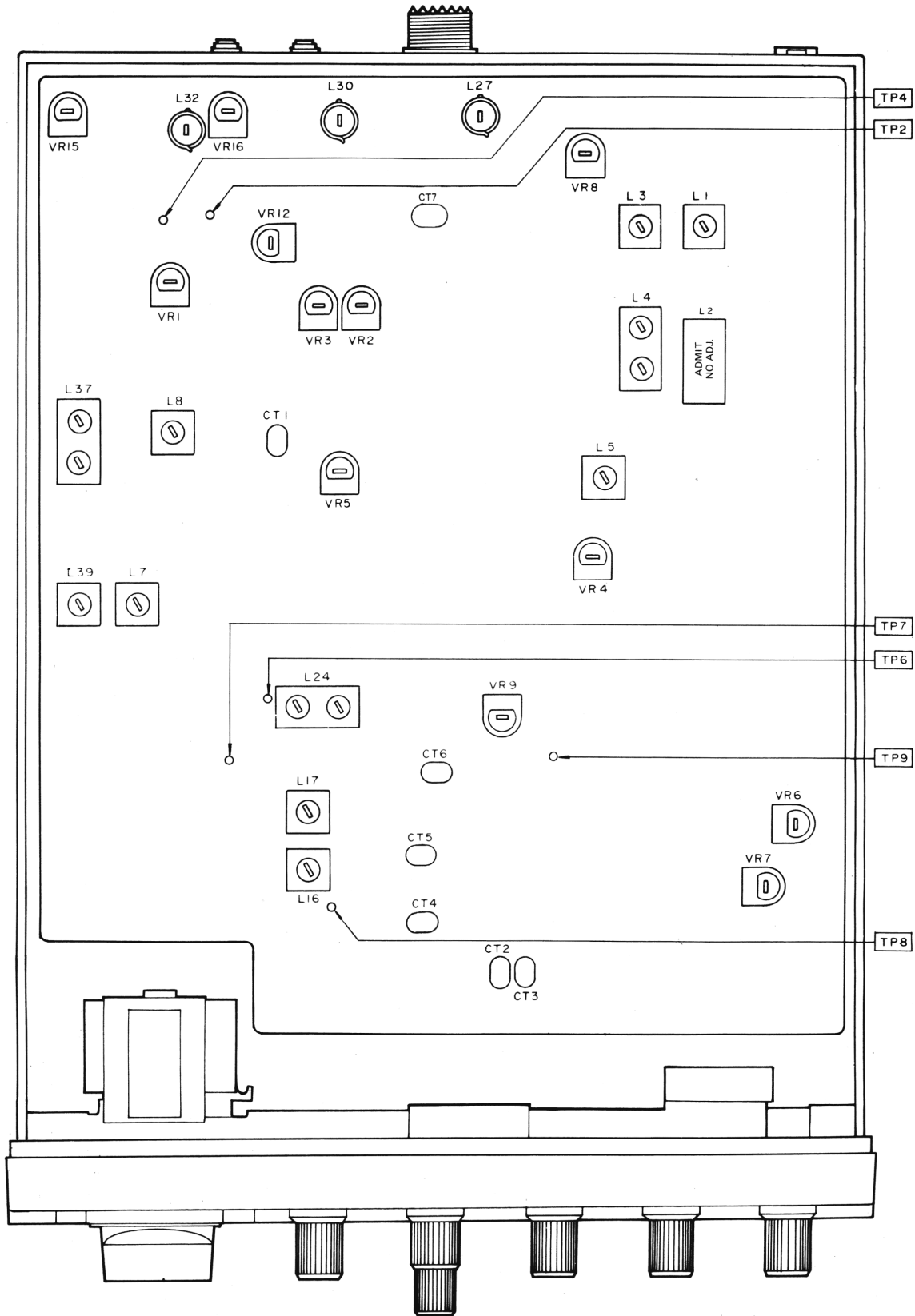



# ALIGNMENT OF PLL AND CARRIER OSCILLATOR

## 1. Test equipment required:

- a. Oscilloscope (DC – 50 MHz)
- b. Frequency counter (0 – 30 MHz)
- c. DC Power Supply (13.8V 100 mA)
- d. DC Voltmeter (10V Maximum 100Kohm/V)
- e. 50 ohm Load

## 2. Alignment procedure: (See page 8)

Connect Test Equipment as shown below.

STEP	PRESET TO	CONNECTIONS	ADJUSTMENT	REMARKS
1	RX, AM, CH19 Clarifier: in center position	TP6	L24	Adjust for max. output.
2	RX, AM, CH 1 Clarifier: in center position	TP7	L17	Adjust for 2 V reading on Voltmeter.
3	Same as Step 1	TP8	L16	Adjust for max. output.
4	Same as Step 1	TP8	CT6	Adjust to obtain 34.985 MHz $\pm$ 20 Hz on frequency Counter.
5	RX, USB, CH19 Clarifier, in center position	TP8	CT4	Adjust to obtain 34.9875 MHz $\pm$ 20 Hz on frequency Counter.
6	RX, LSB, CH19 Clarifier: in center position	TP8	CT5	Adjust to obtain 34.9825 MHz $\pm$ 20 Hz on frequency Counter.
7	TX, LSB, CH19	TP8	VR9	Adjust to obtain 34.9825 MHz $\pm$ 20 Hz on frequency Counter.
8	Same as Step 7	TP9	CT3	Adjust to obtain 7.7975 MHz $\pm$ 5 Hz on frequency Counter.
9	TX, USB, CH19	TP9	CT2	Adjust to obtain 7.8025 MHz $\pm$ 5 Hz on frequency Counter.

## PLL AND CARRIER OSCILLATOR TEST EQUIPMENT SETUP

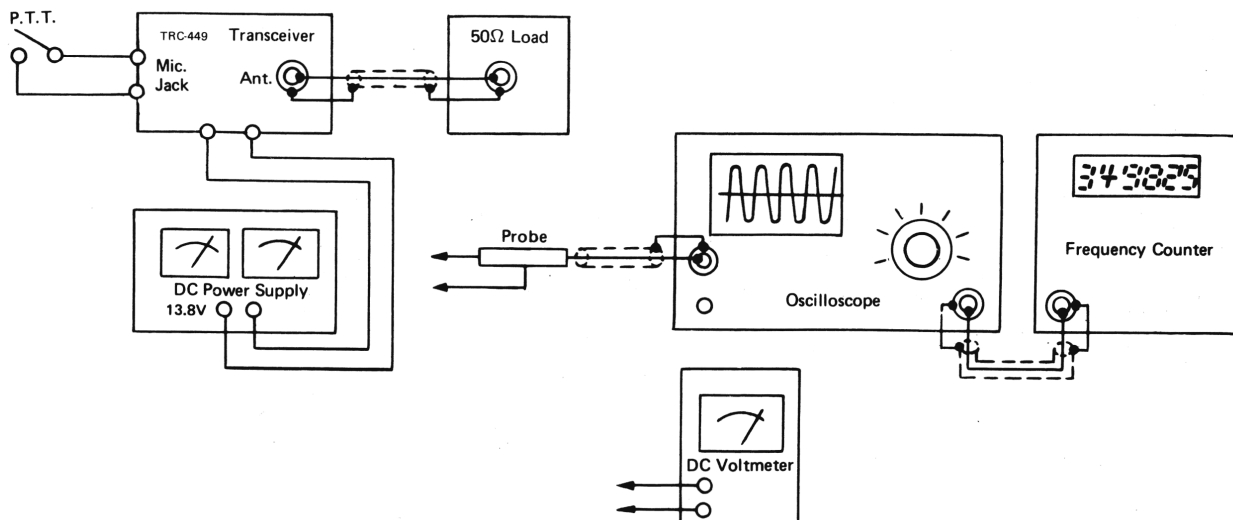

# PLL (Phase Lock Loop) CIRCUIT DESCRIPTION

The PLL (Phase Lock Loop) circuit used in the TRC-457 consists of 6 major components; Voltage Controlled Oscillator (VCO), 1/N Divider, Reference

Oscillator, 1/1024 Divider, Phase Detector and Low Pass Filter.

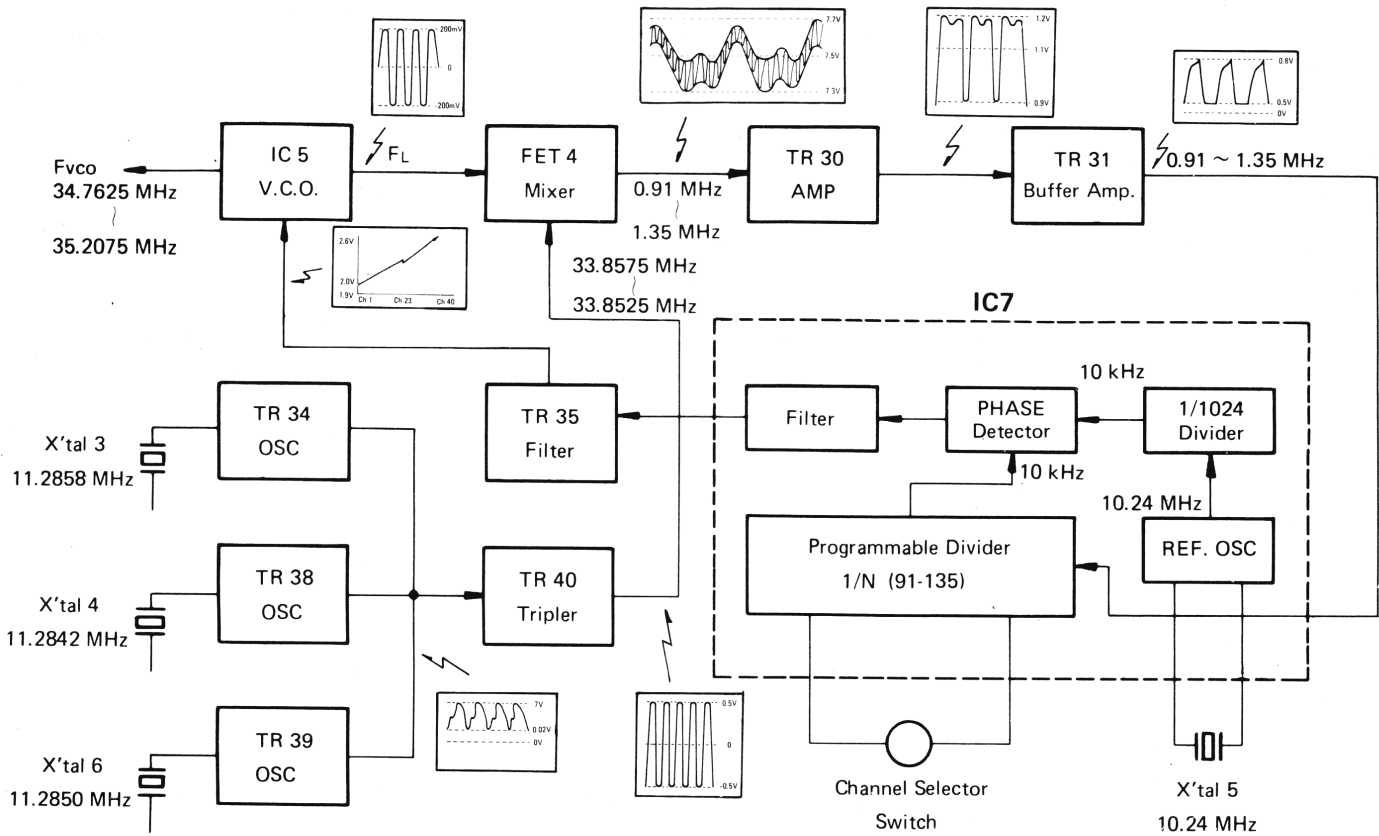

The VCO is an oscillator which controls oscillation frequency in accordance with input voltage changes. The VCO output is mixed with a signal in the transmitter or receiver circuitry. A portion of the VCO frequency is fed to FET4 and mixed with a 33.8525 - 33.8575 MHz frequency from X3, X4 or X6 and then goes through TR30 Amplifier and TR31 Buffer Amp and then added to the 1/N Divider. This is applied to one input of the Phase Detector. "N" for the 1/N Divider is determined by the Channel Selector Switch (by BCD) and varies from 91 to 135.

On the other hand, a 10.24 MHz frequency from the Reference Oscillator is divided to 10 kHz by 1/1024 Divider and applied to another input of the Phase Detector. The Phase Detector detects the difference of these two input signals and produces a voltage which controls the VCO frequency. The Low Pass Filter integrates the output voltage of the Phase Detector which controls the VCO frequency and the 1/N Divider produces a 10 kHz frequency.

Thus the Phase Detector receives two input signals (both 10 kHz). It compares the phase difference of the two, generating an error voltage, which acts on the VCO to bring the two frequencies exactly in-phase. When this condition occurs, the PLL circuit is "locked".

## WAVE FORM OF IC7

IC7 Pin No.	1	2 & 3	4	5 & 6	7 & 12
Wave Form	H = UNLOCKED L = LOCKED where H = 3.5 - 6V L = 0 - 1.0V	2.4V DC -2.4V -----0	2.8V DC -2.8V -----0	5V -----0	5V DC 5V -----0
IC7 Pin No.	8	9	10	11	24
Wave Form	5V -----0	3.2V -----1.5V -----0	5V -----0	5V -----0	5V -----0

Note: Pin No. 13 through 18, 20 & 21 are as in frequency chart.  
Pin No. 19, 22 & 23 are fixed to Low level.

By varying the constant N, the output frequency from the VCO can be locked and varied one 10 kHz step at a time. The constant N is controlled by the Channel Selector Switch. A frequency shift of 2.5 kHz (required for AM RX, USB and AM TX and LSB RX/TX) is obtained by switching to X3, X4 or X6 as shown in Frequency Chart.

For a more detailed description of how this circuit functions, refer to Abbreviated Block Diagram as well as the full Block Diagram and Schematic.

### 1) PLL LOCAL OSCILLATOR

$F_L$ , the frequency of the VCO, is controlled by the PLL synthesizer system as follows. The output frequency of the VCO (IC5) is applied to one of the inputs of the In-loop Mixer FET4 and mixed with the off-set frequency which is generated by the Off-set Oscillator TR34 or TR38 and multiplied by three by Tripler TR40.

The resultant difference frequencies are produced at the output of FET4 as follows:

$$F_1 = F_L - (3 \times F_0)$$

- $F_1$  : Output frequency of FET4
- $F_0$  : Off-set frequency, approximately, 11.2858 MHz on AM or USB mode and 11.2842 MHz on LSB mode.
- $3 \times F_0$ : 33.8575 MHz on AM or USB mode.  
33.8525 MHz on LSB mode.

$F_1$  falls into the range of 910 kHz to 1350 kHz in increments of 10 kHz.

$F_1$  is applied to the Programmable Frequency Divider in the PLL IC, IC7, after being amplified by TR30 and TR31, and then is divided by the programmed-divide-ratio, N, by the Programmable Divider.

The resultant frequency is applied to the Phase Detector in IC7 and is compared (phase-detected) with the reference frequency of 10 kHz applied to another input of the Phase Detector.

The Phase Detector generates the control voltages for VCO to minimize the difference between  $F_1$  divided by N and the reference frequency.

Thus, under locked condition of the loop, the local frequency  $F_L$  is locked stable and is calculated by the following formula:

$$F_L = N \times 10 \text{ kHz} + 3 \times F_0$$

### 2) CHANNEL SELECTION PROGRAM

The divide ratio, N, of the Programmable Frequency Divider is determined by supplied voltages to the program input terminals, Pin No. 13 through Pin No. 22 of the IC7.

The program input voltages for Pin No. 19, No. 22 and No. 23 are fixed to "low level", and the voltages for Pin No. 13 through No. 18, No. 20 and No. 21 are supplied from the channel selector switch S408.

The function of the program input terminals is as follows:

Pin No.	: 13	14	15	16	17	18	19	20	21	22
Function	: 1A	1B	1C	1D	2A	2B	2C	2D	3A	3B
Significant number	: 1	2	4	8	10	20	40	80	100	200

\* Program Input "high level" 19 and 20 are Kept "low" (off).

The divide ratio N of the Programmable divider is provided by the sum of the significant numbers which are effective by supplying "high level" input. For example, when the channel switch is set to Channel No. 1, the input of 1A, 2A and 2D is in "high level" and the others are in "low level". Therefore, the divide ratio N is determined as follows:

$$N = 1 + 10 + 80 = 91$$

In the same manner, the divide ratio N for Channel No. 1 through No. 40 is determined as shown in Frequency Chart.

### 3) TRANSMITTING FREQUENCY CALCULATION

For an example, when the unit is operated on Channel 19, the transmitting frequency is calculated as shown in the following table for each mode.

	AM mode	LSB mode	USB mode
N	113	113	113
$3 \times F_0$ (MHz)	33.8575	33.8525	33.8575
$N \times 10$ kHz (MHz)	1.13	1.13	1.13
$F_L$ (MHz)	34.9875	34.9825	34.9875
$F_{IF}$ (MHz)	7.8025	7.7975	7.8025
$F_t$ (MHz)	27.185	27.185	27.185

# FREQUENCY CHART

CH	ANTENNA OUTPUT FREQUENCY	N	1/N INPUT FREQUENCY	IC7 VOLTAGE								LOCAL OSC OUTPUT FREQUENCY		
				1A	1B	1C	1D	2A	2B	2D	3A	AM.RX	USB&AM.TX	LSB
1	26.965	91	910	1	0	0	0	1	0	1	0	34.765	34.7675	34.7625
2	26.975	92	920	0	1	0	0	1	0	1	0	34.775	34.7775	34.7725
3	26.985	93	930	1	1	0	0	1	0	1	0	34.785	34.7875	34.7825
4	27.005	95	950	1	0	1	0	1	0	1	0	34.805	34.8075	34.8025
5	27.015	96	960	0	1	1	0	1	0	1	0	34.815	34.8175	34.8125
6	27.025	97	970	1	1	1	0	1	0	1	0	34.825	34.8275	34.8225
7	27.035	98	980	0	0	0	1	1	0	1	0	34.835	34.8375	34.8325
8	27.055	100	1000	0	0	0	0	0	0	0	1	34.855	34.8575	34.8525
9	27.065	101	1010	1	0	0	0	0	0	0	1	34.865	34.8675	34.8625
10	27.075	102	1020	0	1	0	0	0	0	0	1	34.875	34.8775	34.8725
11	27.085	103	1030	1	1	0	0	0	0	0	1	34.885	34.8875	34.8825
12	27.105	105	1050	1	0	1	0	0	0	0	1	34.905	34.9075	34.9025
13	27.115	106	1060	0	1	1	0	0	0	0	1	34.915	34.9175	34.9125
14	27.125	107	1070	1	1	1	0	0	0	0	1	34.925	34.9275	34.9225
15	27.135	108	1080	0	0	0	1	0	0	0	1	34.935	34.9375	34.9325
16	27.155	110	1100	0	0	0	0	1	0	0	1	34.955	34.9575	34.9525
17	27.165	111	1110	1	0	0	0	1	0	0	1	34.965	34.9675	34.9625
18	27.175	112	1120	0	1	0	0	1	0	0	1	34.975	34.9775	45.9725
19	27.185	113	1130	1	1	0	0	1	0	0	1	34.985	34.9875	34.9825
20	27.205	115	1150	1	0	1	0	1	0	0	1	35.005	35.0075	35.0025
21	27.215	116	1160	0	1	1	0	1	0	0	1	35.015	35.0175	35.0125
22	27.225	117	1170	1	1	1	0	1	0	0	1	35.025	35.0275	35.0225
23	27.255	120	1200	0	0	0	0	0	1	0	1	35.055	35.0575	35.0525
24	27.235	118	1180	0	0	0	1	1	0	0	1	35.035	35.0375	35.0325
25	27.245	119	1190	1	0	0	1	1	0	0	1	35.045	35.0475	35.0425
26	27.265	121	1210	1	0	0	0	0	1	0	1	35.065	35.0675	35.0625
27	27.275	122	1220	0	1	0	0	0	1	0	1	35.075	35.0775	35.0725
28	27.285	123	1230	1	1	0	0	0	1	0	1	35.085	35.0875	35.0825
29	27.295	124	1240	0	0	1	0	0	1	0	1	35.095	35.0975	35.0925
30	27.305	125	1250	1	0	1	0	0	1	0	1	35.105	35.1075	35.1025
31	27.315	126	1260	0	1	1	0	0	1	0	1	35.115	35.1175	35.1125
32	27.325	127	1270	1	1	1	0	0	1	0	1	35.125	35.1275	35.1225
33	27.335	128	1280	0	0	0	1	0	1	0	1	35.135	35.1375	35.1325
34	27.345	129	1290	1	0	0	1	0	1	0	1	35.145	35.1475	35.1425
35	27.355	130	1300	0	0	0	0	1	1	0	1	35.155	35.1575	35.1525
36	27.365	131	1310	1	0	0	0	1	1	0	1	35.165	35.1675	35.1625
37	27.375	132	1320	0	1	0	0	1	1	0	1	35.175	35.1775	35.1725
38	27.385	133	1330	1	1	0	0	1	1	0	1	35.185	35.1875	35.1825
39	27.395	134	1340	0	0	1	0	1	1	0	1	35.195	35.1975	35.1925
40	27.405	135	1350	1	0	1	0	1	1	0	1	35.205	35.2075	35.2025

0 = Low level (0 – 1.0 volt)

1 = High level (3.5 – 6 volts)

# 1. AUDIO LIMITER AND AUTOMATIC MODULATION CONTROL

The modulation control for this model consists of 2 loops of AMC which detect a signal from the output of the audio limiter (mic preamp) and from the audio power amp and feed it back to limiter diodes.

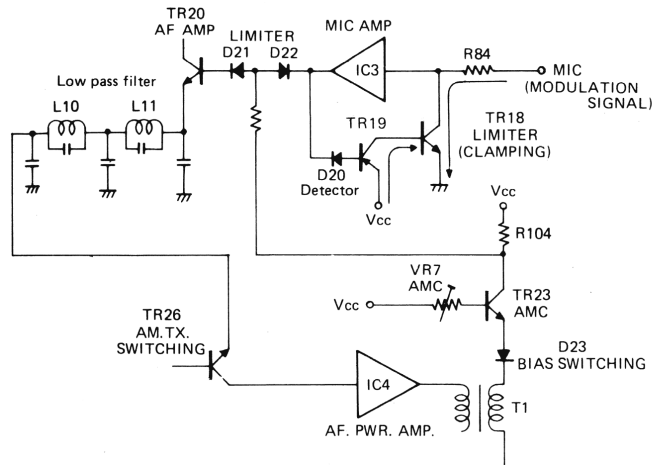

Fig. 1 Circuit Diagram of Audio Limiter and Automatic Modulation Control

## 1-A. AUDIO LIMITER

The mic signal is applied to pin 2 of IC3. The signal is picked up at Pin 6 and detected by D20 (negative part of waveform). This current flows into the base of TR19, effectively decreasing its C-E impedance; which increases the Vcc applied to TR18's base. And TR-18's C-E impedance drops as its base current increases. This provides a variable voltage divider at the input of IC3 (dividing between R84 and TR18), thus making it possible to attenuate and control the modulation signal right at the input to the mic gain stages.

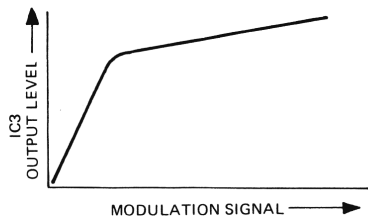

Fig. 2 Audio Limiter Characteristics

## 1-B. AUTOMATIC MODULATION CONTROL (AMC)

The output level of IC3 is already controlled by the audio limiter. However, to control maximum modulation more precisely and stably, the AMC circuit which feeds back the output amplifier(IC4) into the limiter diode(D21, D22) is provided. The output of IC3 is subjected to impedance matching

by the AF AMP(TR20) through the low pass filter(L10, L11) and TX(AM) switching(TR22). The output of IC4 is subjected to impedance matching by the output transformer(T1) and supplied to the TX FINAL and DRIVER stage. This modulation signal is detected at the secondary of T1 by the bias switching diode(D23) and makes collector current flow in TR23, AMC transistor. At this time, a voltage drop is developed across the resistor(R104) which causes collector voltage to decrease and forward bias current of both D21 and D22 is reduced. In other words, the output voltage of IC3 is clipped for both positive and negative. However, the clipped waveform as shown in Fig. 2-D causes the band-width to increase, thus a low pass filter(L10, L11), which has the characteristics as shown in Fig. 3, is used.

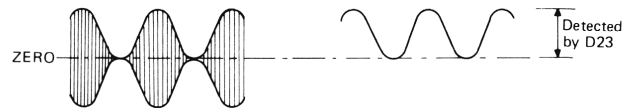

Fig. 2A Modulation Wave at Antenna Terminal

Fig. 2B Output at T-1

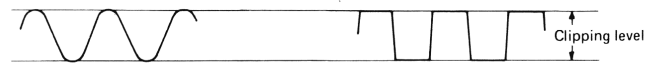
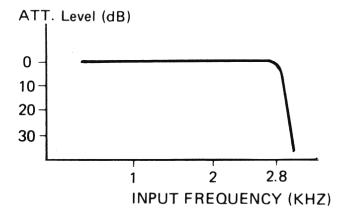

Fig. 2C Limiter Output with small input signal

Fig. 2D Limiter Output with large input signal

Fig. 3 Low Pass Filter Frequency Response



## 2. AUTOMATIC LIMITER CIRCUIT(ALC) (SSB mode)

Both AMC and ALC circuits function for AM and SSB. For SSB we have an additional circuit as described here.

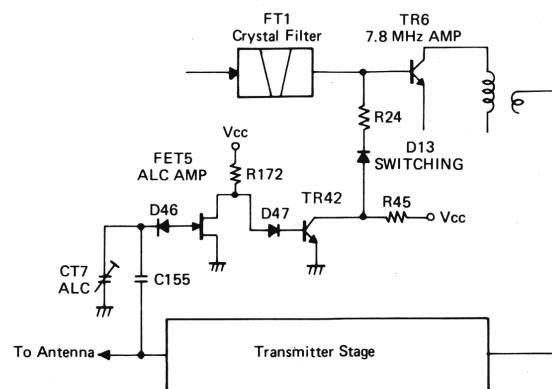

Fig. 4 ALC circuit (abbreviated)

The SSB signal is processed through FT1, amplified by the 7.8 MHz amplifier (TR6) and fed to the TX stage. The peak-to-peak power output of the TX stage is subjected to negative detection by D46 and applied to the gate of FET5 ALC amplifier. At this time, if the gate becomes negative, drain voltage is increased up to about  $V_{cc}$  level. This increased voltage is applied to the base of TR42 ALC amplifier, and therefore, base current is increased which also increases collector current; this increases R45 voltage drop and decreases collector voltage.

The base bias of TR6 is supplied from the collector of TR42 through the switching diode (D13). With a decrease in the collector voltage of TR42, the base bias current of TR6 is reduced and the operating point is shifted, thus amplifier output level is decreased as shown in Fig.5. This decrease will limit the power output at the antenna terminal.

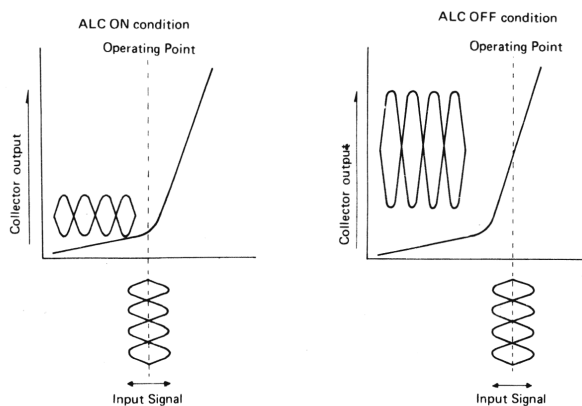

Fig. 5 Operating Characteristics of TR-6

### 3. NOISE BLANKER CIRCUIT

#### 3-A. NOISE AMPLIFIER CIRCUIT

The Noise Blanker circuit is tuned to 23 MHz. Any noise that exists in the 27 MHz frequency range will also be present at 23 MHz. L1 is tuned to 23 MHz, IC1 amplifies the 23 MHz band of frequencies and L2 provides further tuning. This signal is then amplified and detected (utilizing the non-linear characteristic portion of the operating curve) by TR2, N.B. AMP. Also, the phase of the signal is reversed in TR2 and fed to the base of TR3 for further amplification. Base current flows when a pulse is applied; then the C-E impedance is reduced to about 10-20 ohms. Since the collector is connected to the hot side of L5 (RX 7.8 MHz), the primary side of L5 is in effect short-circuited and so the pulse noise is eliminated from the Receive signal.

#### 3-B. N.B. AGC CIRCUIT

In some N.B. circuits, under conditions of high signal and high noise, when N.B. is turned on, there is more noise than with N.B. off. This is due to a lack of AGC. To prevent this effect, a portion of the 27 MHz signal is picked off of L4 and applied through FET601 and TR601, N.B. AGC amplifiers. This signal is detected by D601 and D602 and applied through D603 to the base of TR1, which drives the base into saturation. At the same time, collector current increases, which drops most of  $V_{cc}$  across R4; thus reducing the gain of the N.B. Amplifier chain. This AGC effectively controls the N.B. loop and its effect on the 27 MHz RF amplifier circuitry. N.B. AGC is set to operate with an incoming 27 MHz signal level of 100-500  $\mu V$ .

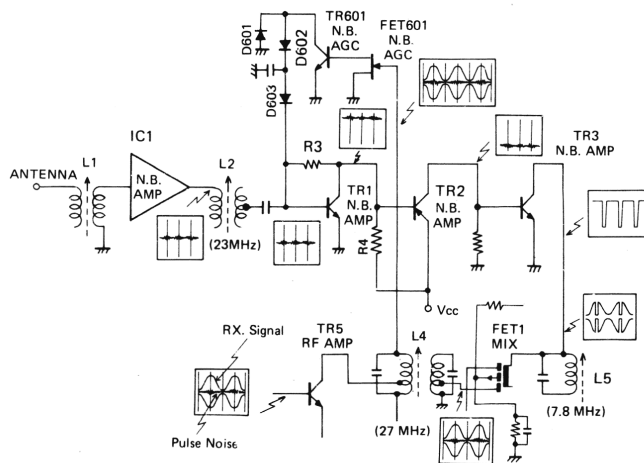

Fig. 6 Noise Blanker Circuit

# ALIGNMENT OF TRANSMITTER SECTION

## 1. Equipment Required:

- a. AF Oscillator (two required)
- b. AF VTVM (Full scale: 1V DC with RF probe)
- c. DC VOM
- d. RF Power Meter
- e. 50 ohm load and Attenuator
- f. Oscilloscope
- g. RF VTVM
- h. Tunable Field Strength Meter (Wave meter) (or Spectrum Analyzer)
- i. DC Power Supply (13.8 V/3 amp.)

## 2. PROCEDURE (See page 8)

Connect Test Equipment as shown below.

STEP	PRESET TO	ADJUSTMENTS	REMARKS
1	S1, S2: off USB, TX mode	VR15	Break circuit at TP4, place DC mA Meter in series. Adjust for approximately 40 mA reading. Restore circuit.
2	Same as step 1	VR16	Break circuit at TP2, place mA Meter in series. Adjust for approximately 15 mA reading. Restore circuit.
3	Same as step 2	VR4	Adjust for minimum carrier leakage for both USB and LSB on Oscilloscope (or Spectrum Analyzer, if available).
4	VR6: fully CW CT7: Max. Cap. AF OSC1: 500 Hz AF OSC2: 2400 Hz S1 and S2: ON	L30, L32 L37, L39	Adjust level of OSC1 and OSC2 for 500 mV reading on AF VTVM and then adjust coils for max. reading on RF VTVM.
5	Same as step 4	CT7	Adjust for 24 volt reading on RF VTVM.
6	S1 and S2: OFF AM, TX mode	VR8	Adjust for 3.8 to 4.0 watt reading on RF Power Meter.
7	S1: ON AF OSC: 10000 Hz	VR6	Adjust output of OSC1 for 0.5 mV reading on AF VTVM then adjust VR6 for 50% modulation on Scope.
8	Same as step 7	VR7	Adjust output of OSC1 for 200 mV reading on AF VTVM then adjust VR7 for 95 to 98% modulation on Scope.
9	Same as step 8	L27	Adjust L27 to show min. 2nd harmonic (54 MHz) on Tunable Field Strength Meter (or Spectrum Analyzer, if available).
10	S1 and S2: OFF AM, TX mode	VR12	Adjust VR12 so the TRC-449's power meter reads between red and white area.

## TRANSMITTER TEST EQUIPMENTS SETUP

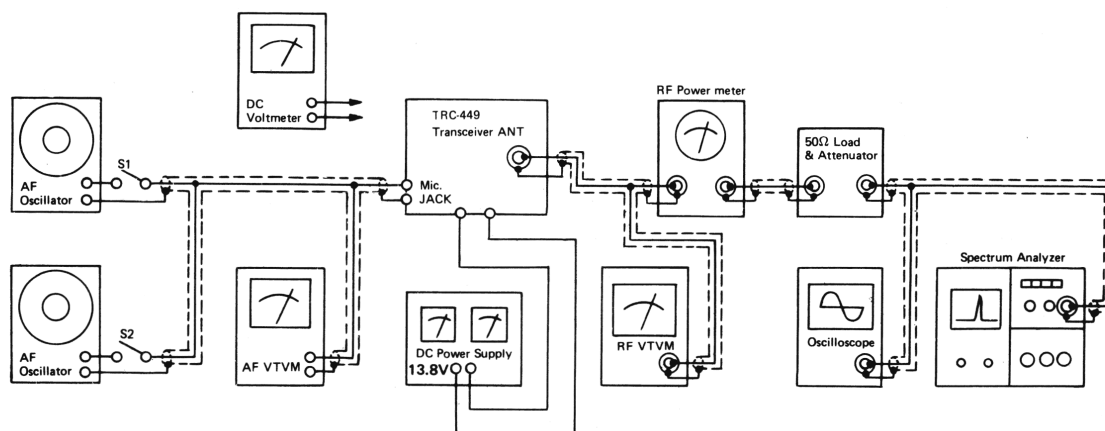

# ALIGNMENT OF RECEIVER SECTION

## 1. Equipment Required

- a. RF Signal Generator (455 kHz and 27 MHz Band, 50 ohm output impedance)
- b. AF VTVM
- c. Oscilloscope
- d. RF Voltmeter
- e. DC Power Supply
- f. 8 ohm load

## 2. Procedure (See page 8)

Connect Test Equipment as shown below.

**Note;**

L2 is adjusted at the factory so no adjustment should be made.

STEP	SIGNAL GENERATOR SETUP	PRESET TO	ADJUSTMENT	REMARKS
1	27.185 MHz, modulated 1 kHz (30%)	RX, AM, CH 19 VOL. & RF Gain Control : Max. SQUELCH : Min. ANL & N.B.: Off	L3, L4, L5, L6, L7, L8	Adjust for a max. output.
2	Same as Step 1	Same as Step 1	VR 5	Adjust for 2 volts output with a SG output level of 0.5 $\mu$ V.
3	1 kHz NO MOD	RX, USB, CH 19 VOL. & RF Gain Control: Max. SQUELCH : Min. ANL & NB : Off	CT 1	Adjust for 2 volts output with a SG output level of 0.25 $\mu$ V.
4	Same as Step 3	Same as Step 3	VR 1	Adjust for a reading of S-9 on the Transceiver's S-Meter, with SG output level of 100 $\mu$ V.
5	Same as Step 1 Set RF Generator level to 1 mV	RX, USB, CH 19 VOL. & RF Gain Control: Max. SQUELCH : Max. ANL & NB : Off	VR 3	Adjust so squelch circuit just opens with 1 mV signal.
6	Same as Step 1	RX, USB, CH 19 RF Gain Control : Max. SQUELCH : Min. ANL & NB : Off	(Volume Control)	Adjust for 2 volts output with a SG output level of 0.5 $\mu$ V.
7	Same as Step 1	RX, USB, CH 19 RF Gain Control : Min. SQUELCH : Min. ANL & NB : Off	VR 2	Adjust for 2 volts output with a SG output level of 50 $\mu$ V.
8	23.5 MHz NO MOD	RX, USB, CH 19 RF Gain Control : Max. SQUELCH : Min. NB : On ANL : Off	L1	Adjust for max. output with Volt-Meter connected to TP5, with SG output level of 200 $\mu$ V.

## RECEIVER TEST EQUIPMENT SETUP

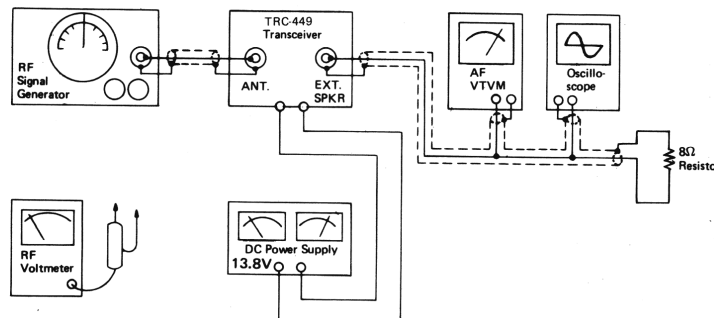



## 5. TROUBLESHOOTING HINTS

### UNIT WILL NOT TURN ON

1. Broken DC Power cable.
2. Fuse blown. Be sure you check the cause.
3. Defective power switch.
4. Defective wires or poor soldering in power supply circuit.

### NO RECEIVE SOUND

1. Defective RF circuit in receiver.
2. Defective Noise Blanker.
3. Defective AGC circuit.
4. Defective PLL circuit.
5. Defective antenna connector.

### NO NOISE

1. Defective RX power circuit.
2. Defective RX audio circuit.
3. Defective PLL circuit and/or channel switch.
4. Defective squelch.
5. Defective PA-CB switch and/or EXT SP. Jack.

### NO TRANSMISSION

1. Broken or bad contact in microphone connector and/or push-to-talk switch.
2. Broken or bad contact in antenna connector.
3. Defective Relay.
4. Defect in power supply.
5. Defect in PLL and/or Carrier Oscillator (Improper adjustment).
6. Inoperative microphone amplifier and/or balanced modulator in SSB mode.
7. Defective TX AMP.  
(Between mixer and final stage)

### NO MODULATION

1. Defective microphone.
2. Defective microphone connector.
3. Defective TR20 or IC4, (AM mode.)
4. Inoperative microphone amplifier, (both AM and SSB modes.)

## FOR MORE HINTS, SEE BELOW:

---

### NO RECEIVE SOUND

- A) Check for short circuit or broken wire in the winding of the output transformer(T-1) or cold soldering between the wires and printed circuit board. The DC resistance of the output transformer winding is approximately 0.2 ohm on the primary side and 0.5 ohm on the secondary side (use accurate V.O.M. if available to check this resistance).
- B) Defective Audio Power IC4.  
Check the DC voltage at pin 10 of IC4. If voltage reads approximately 7 V (supply voltage/2), then problem is not with this IC.
- C) Squelch is ON all the time.  
If the gate voltage of FET3 is +6 V or less with Squelch Control in the C.C.W. position, the Squelch Circuit is defective. So, check the circuits of TR12, TR13 and TR14 and also ground terminal of Squelch Control (VR404) for cold soldering.  
If the collector voltage of TR12 is 6 V or more, check the circuit of TR21 and Volume Control (VR405).
- D) If the Signal strength meter deflects when the external antenna is connected, you can assume that RF thru IF stages are OK. So, checks should be made on detector and ANL circuit (D10, D11 and D12).

If a negative voltage appears at the cathode of D12, detector and ANL circuit should be all right, so, check the circuit of TR15.

If the collector voltage of TR15 is approx. 6 to 7 V, TR15 is all right.

- E) No receive sound even with carrier oscillation (7.8 MHz) on USB/LSB mode.  
In case of no signal strength meter deflection at the check of D) above: If a RF voltage of 2V /P-P(34 MHz) or more is at the first gate of FET1 and this frequency is as shown in the frequency chart, the local oscillator (PLL) should be all right.
- F) Check the voltage of each part of the following stages: TR9, TR8, TR6, FET1, TR5 and TR4 (in this order).

### NO TRANSMISSION (AM)

- A) Connect the DC meter in series with DC power cable. If reading is 1.5 A or more, you can assume that there is contact failure between relay and antenna circuit or short circuit between final transistor (TR43) and antenna circuit.  
If the current reads 1.5 A or less, check prior stages.
- B) If the output voltage (7.8 MHz) of carrier oscillation (TR27, TR28) is 100 mV or more at TP-9, the carrier oscillation circuit is all right.

- C) If a RF voltage of 20 mV/P-P or more at the base and 300 mV/P-P or more at the collector of the 7.8 MHz AMP (TR7), the 7.8 MHz AMP is all right.  
If no RF voltage is present at the base, check D7 and D35 circuits.
- D) If a RF voltage of 34 MHz, 2 V/P-P or more is readable at the first gate of the mixer (FET7) no problem should be expected with Local Oscillator.
- E) Check DC and RF voltages of each of the following circuits: TR43, TR44, TR45, FET6 and FET7 (in this order).
- F) If voltages do not appear at the collector of TR43 or TR44, check the regulators (TR25 or TR26). If the regulator has a DC output of approx. 5 to 7 V. the regulator should be all right.

- B) If a pulse noise is amplified to 0.7 V/P-P or more at the base of TR3 when an ignition noise (or pulse noise) of 100 mV/P-P or more is applied to the antenna, the circuits of TR1 and TR2 should be all right. And if a pulse noise of approx. 0.2 V/P-P is produced at the collector of TR3, it also is all right.

#### **NO LED CHANNEL INDICATOR LIGHTS**

- A) In the event a specific channel fails to light, it is probable that there is an open circuit in the LED display or bad contact in the channel selector switch.
- B) If all channels fail to light, the regulator (TR36 & TR37) circuit is defective.

#### **NO TRANSMISSION (SSB)**

- A) If AM transmit and modulation are working properly, the problem is in the circuit of 7.8 MHz AMP (TR6) or in the circuit of Balanced Modulator (IC2) or in the Microphone AMP (TR16).  
If no RF voltage of 7.8 MHz, 50 mV/P-P appears at pin 8 of IC2, check circuits from TR28 to pin 8 of IC2.  
If no audio signal of approx. 70 mV/rms appears at pin 1 of IC2 under modulation, check circuits before TR16.
- B) If the voltage reading at pin 8 and pin 1 of IC2 are correct then problems are with TR6 bias circuit or D6.
- C) If the output of TR6 is produced properly check item D) and E) of NO TRANSMIT (AM) above.

#### **NO AM MODULATION**

The signal in the modulation circuit flows through IC3 - D22 - D21 - TR20 - TR22 - IC4. Therefore check to determine at what stage this signal ceases (to isolate a defective part). If no signal appears at pin 2 of IC3, it is probable that there is a short circuit between the collector and emitter of the clamping transistor (TR18) or between the collector and emitter of the TR19.

#### **NO NOISE BLANKER OPERATES**

- A) If the RF output voltage of TP-5 is 100 mV or less with Noise Blanker ON, when signal of 23.5 MHz 200  $\mu$ V carrier is applied to antenna, check the RF AMP circuits (IC1) and L1 and L2.

# 6. PLL CIRCUIT TROUBLESHOOTING HINTS

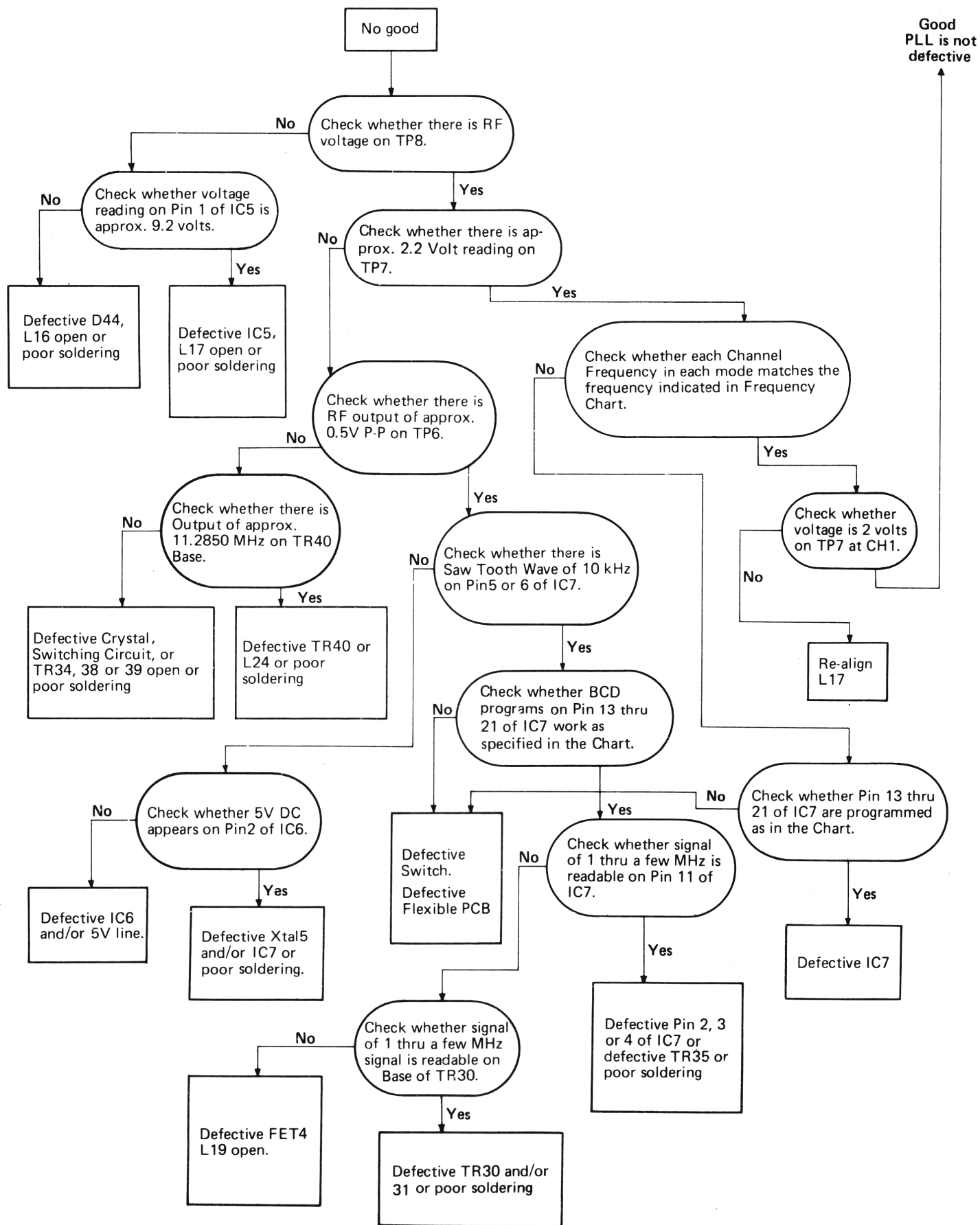

# 7. IC, TRANSISTOR & DIODE LEAD IDENTIFICATIONS

IC-1,  $\mu$ PC577H  
IC-3,  $\mu$ PC592H2

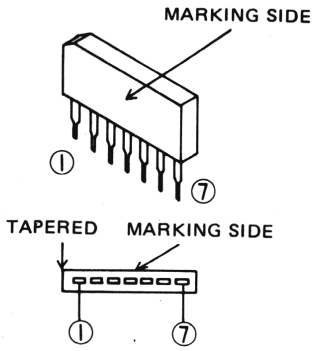

IC-2, MC1496N

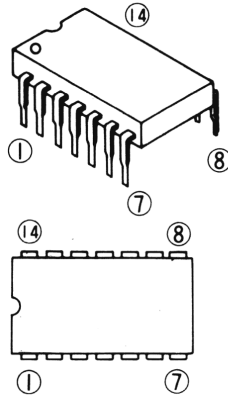

IC-4,  $\mu$ PC1156H

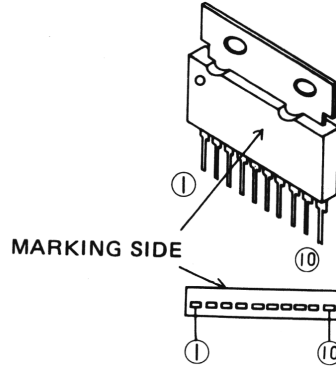

IC-5, UHIC-005

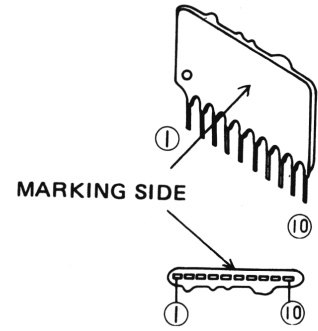

IC-6,  $\mu$ PC78L05

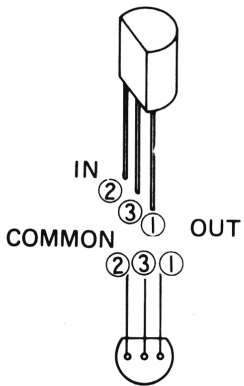

IC-7,  $\mu$ PD858C

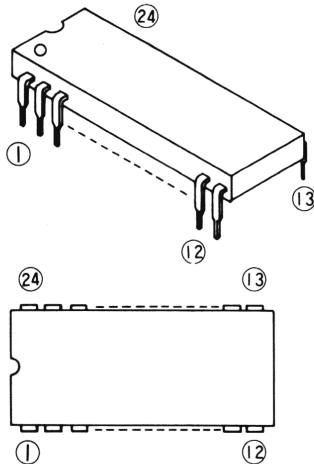

FET-1, 4, 7

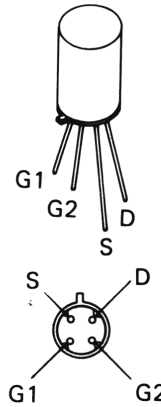

FET-2, 6, 601



FET-3, 5

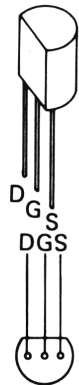

TR-1 ~ TR-23  
TR-26 ~ TR-34  
TR-37 ~ TR-42  
TR-45  
TR-601

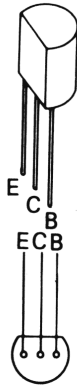

TR-24, 25, 36  
TR-43, 44

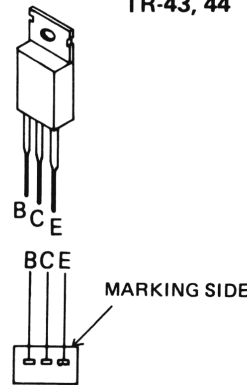

LED  
LR-070 2R

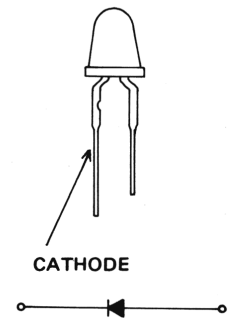

TLR-321

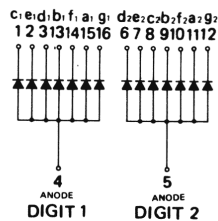
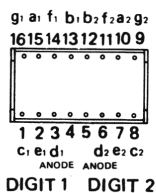
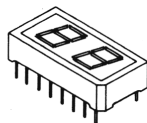

DIODES : 1S2473, 1N60P  
SR1K-2

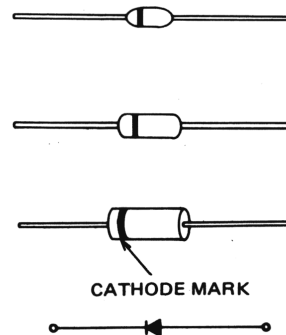

# 8. IC & COMPOUND PARTS INTERNAL DIAGRAMS

**IC-1,  $\mu$ PC577H**

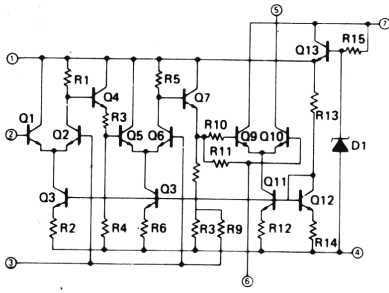

**IC-2, MC1496N**

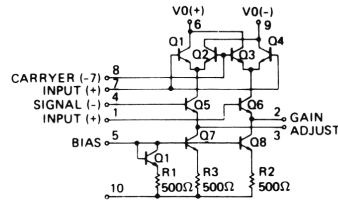

**IC-3,  $\mu$ PC592H2**

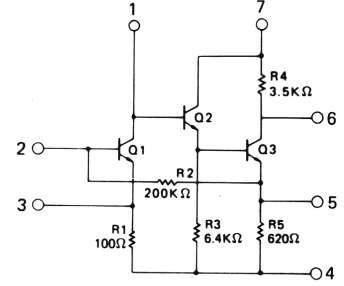

**IC-4,  $\mu$ PC1156H**

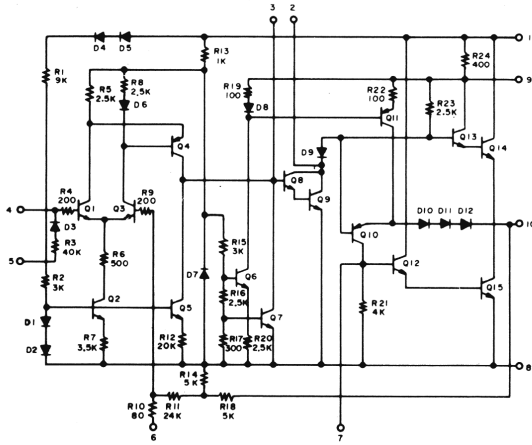

**IC-5, UHIC005**

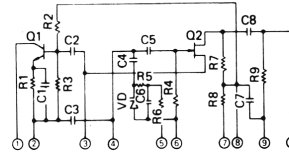

**IC-6,  $\mu$ PC78L05**

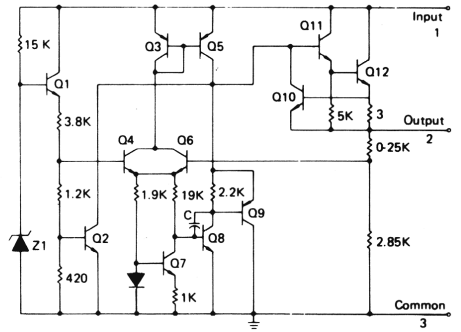

**IC-7,  $\mu$ PD858C**

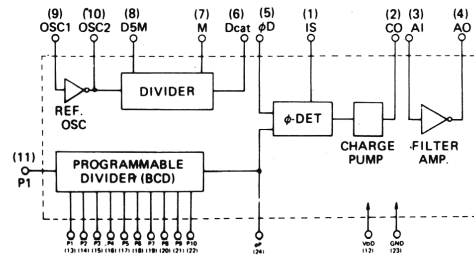

**CC-1 & CC-2 (HA-003)**

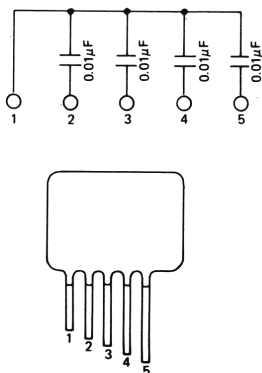

**RR-1 (HA-004)**

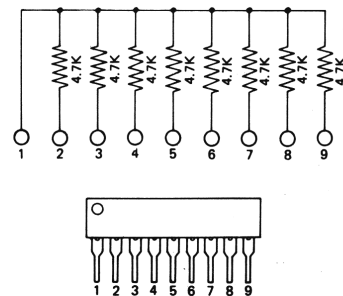

## 9. CHANNEL SWITCH P.C. BOARD (FLEXIBLE)

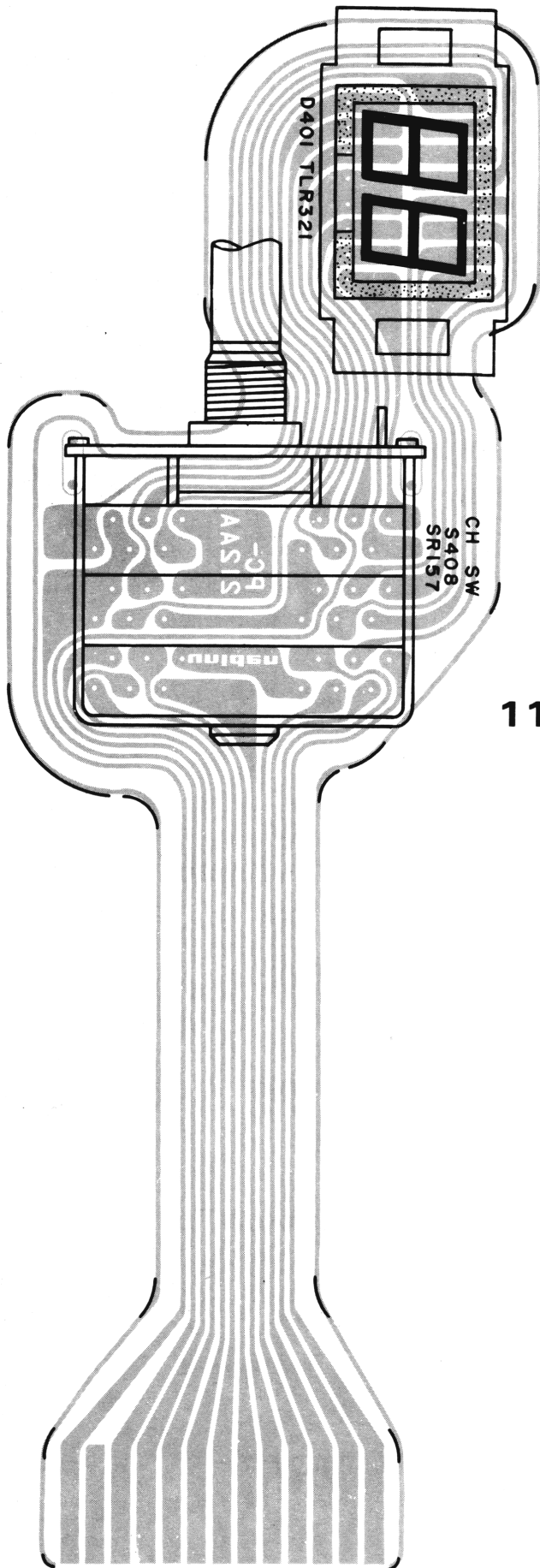

## 10. NOISE BLANKER P.C. BOARD

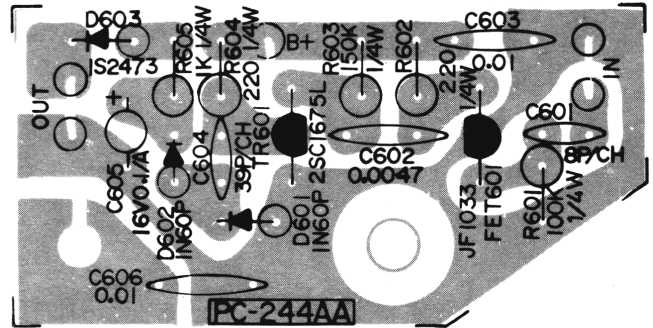

## 11. SPEAKER JACK P.C. BOARD

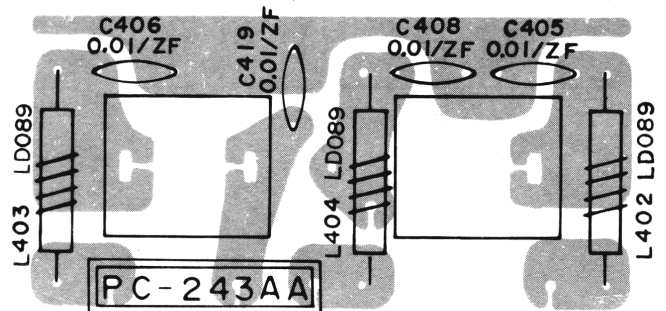

(TOP VIEW)

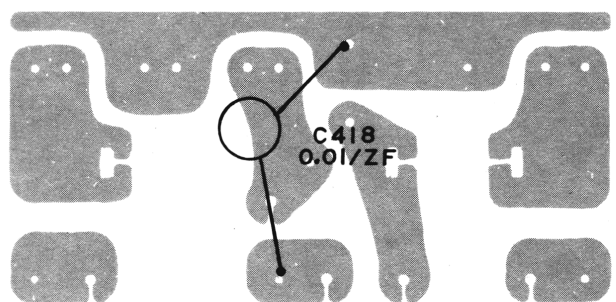

(BOTTOM VIEW)

# 12. MAIN P.C. BOARD (TOP VIEW)

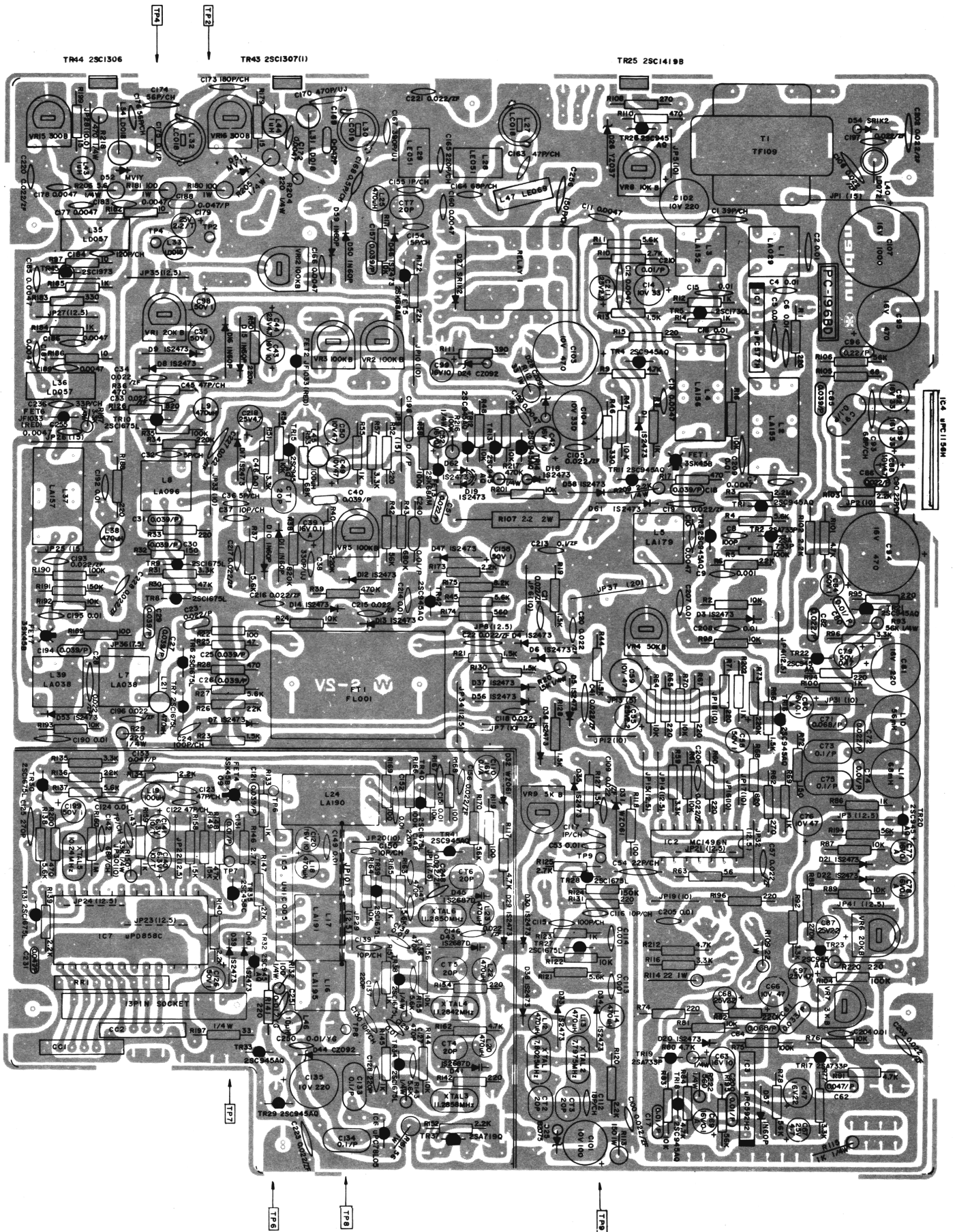

# 13. MAIN P.C. BOARD (BOTTOM VIEW)

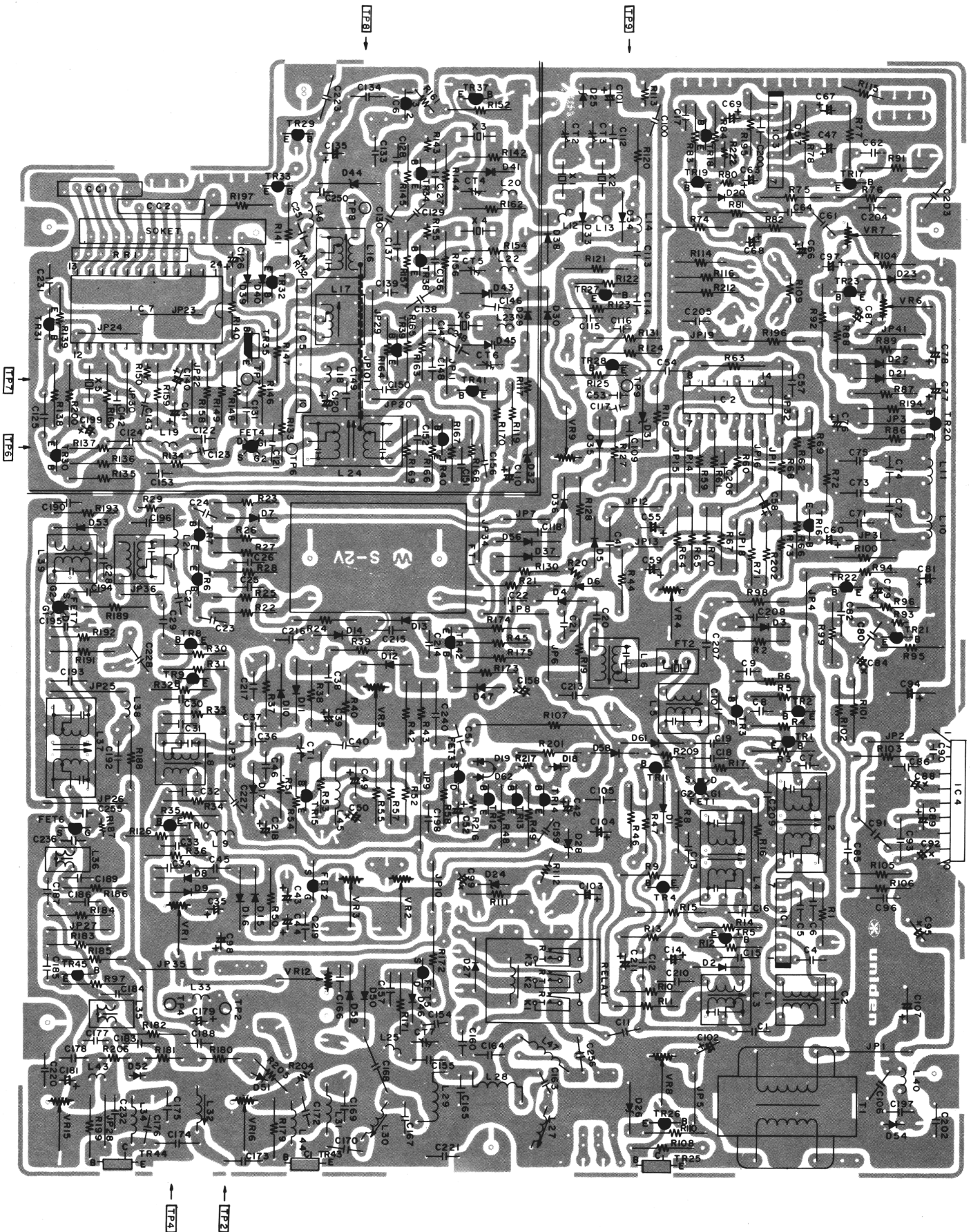



# 14. ADDITIONAL PARTS ON THE BOTTOM

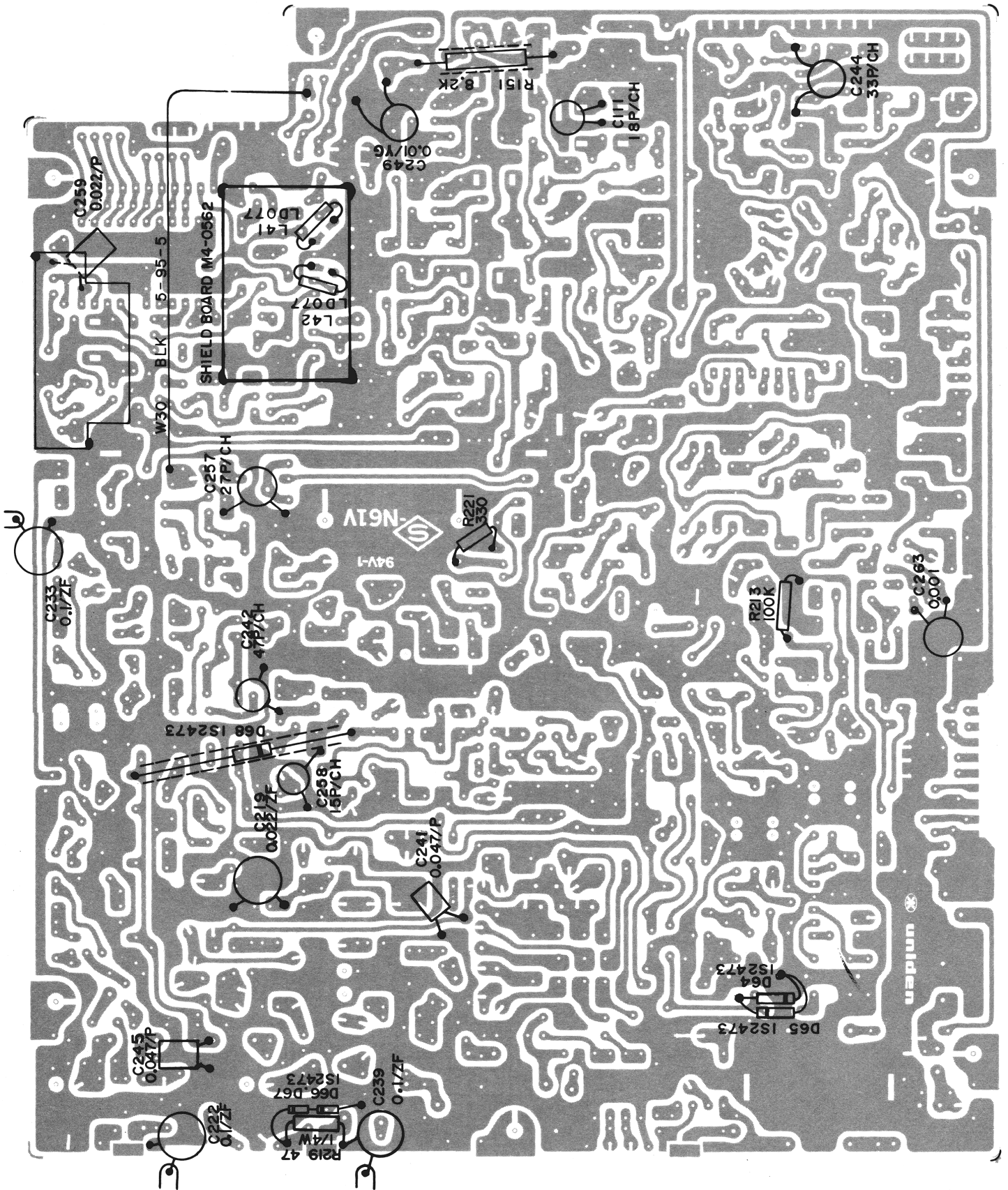

# 15. WIRING DIAGRAM

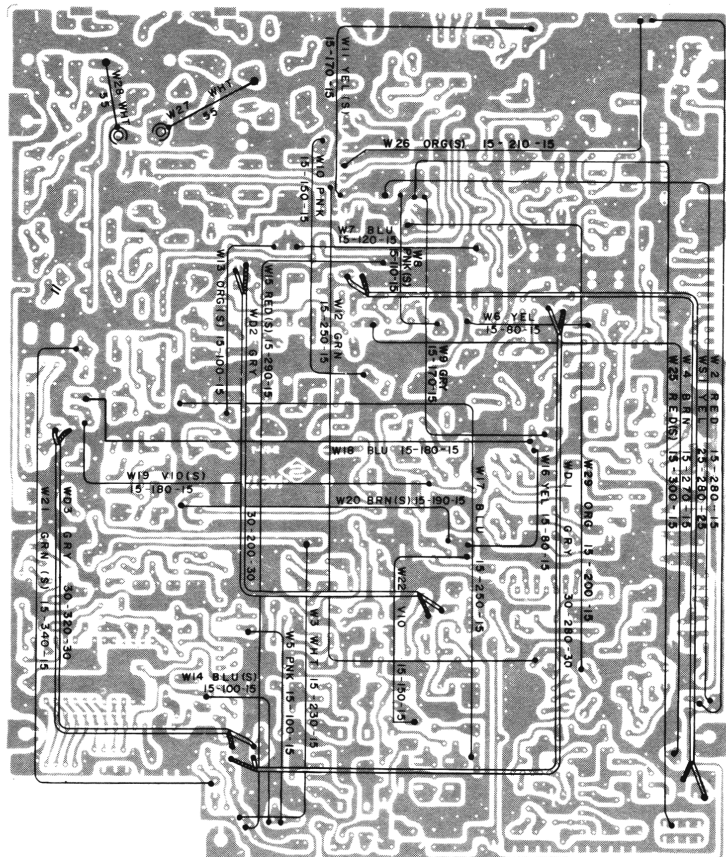
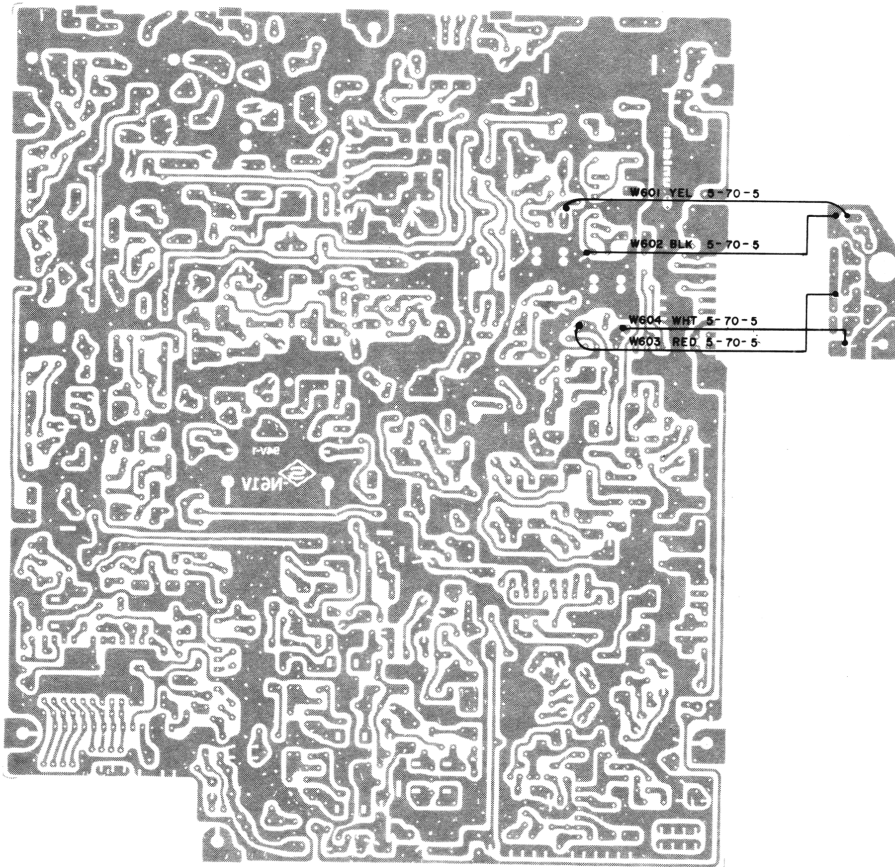

# 16. WIRING DIAGRAM

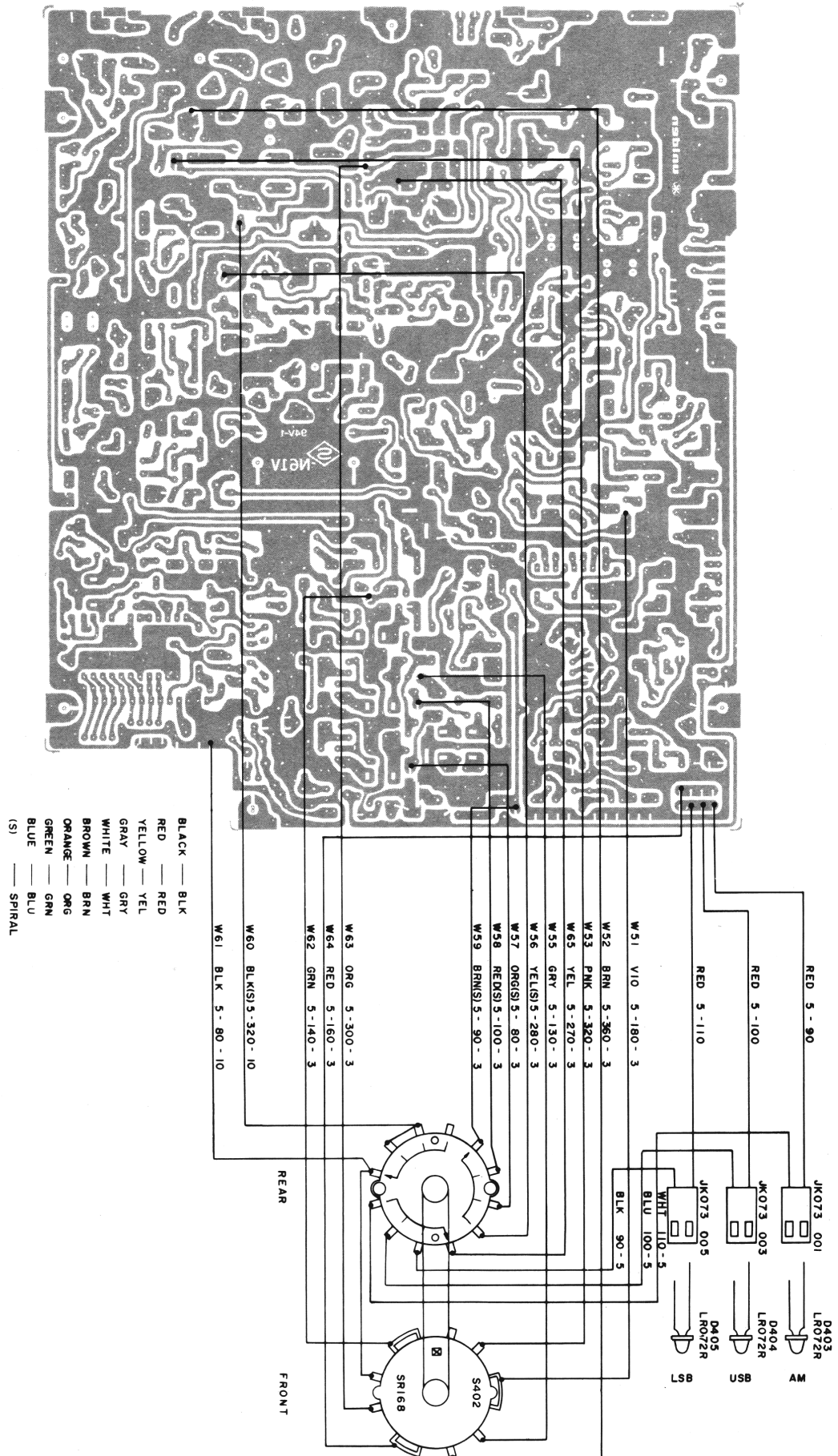

# 17. WIRING DIAGRAM

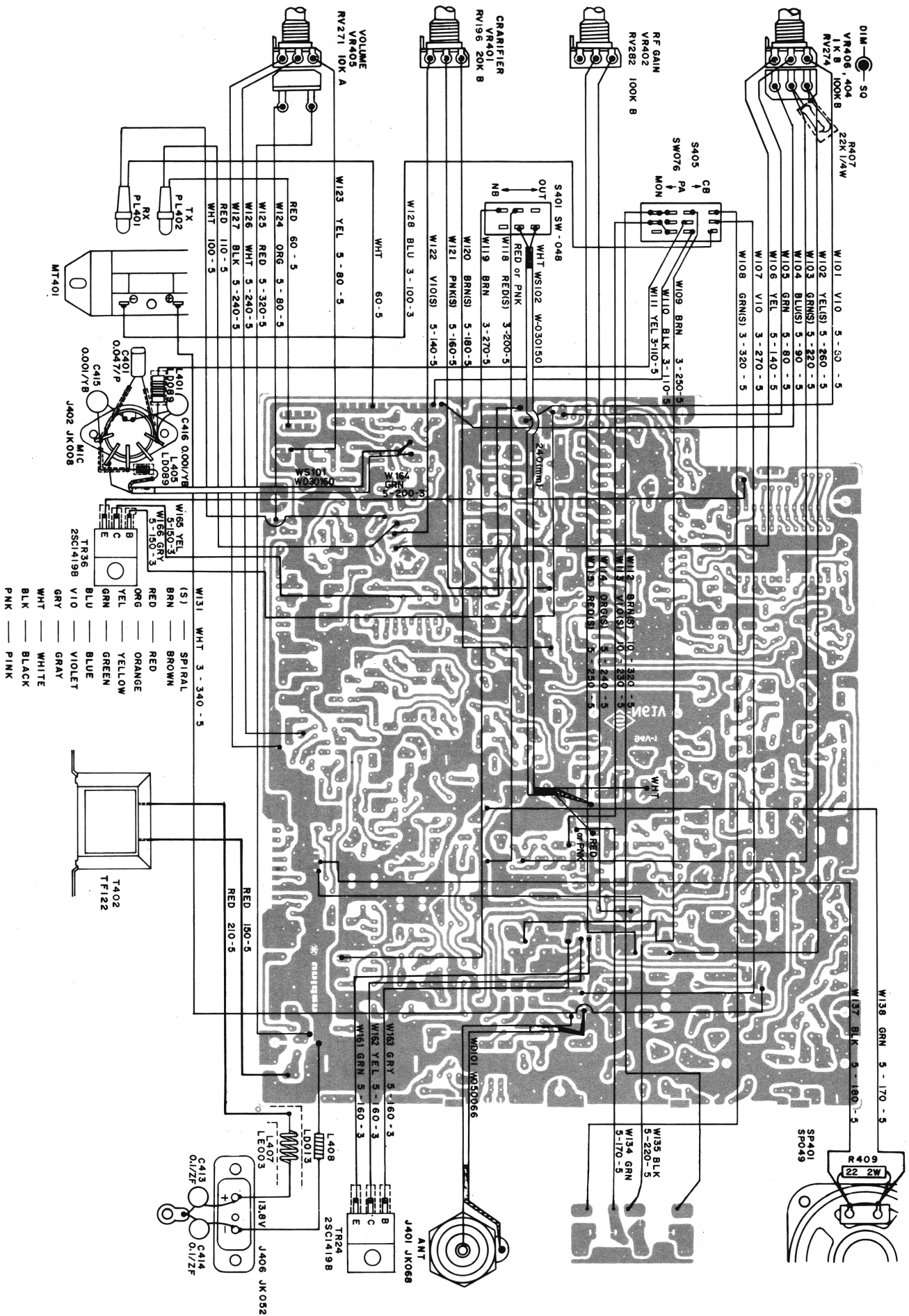

# 18. ELECTRICAL PARTS LIST

(See Page 30 & 31 for Capacitor Tolerance & Temp. Coding System)

REF. NO.	DESCRIPTION	RS PART NO.	MFRS PART NO.
<b>CAPACITORS</b>			
C-1	Ceramic Capacitor, 39pF 50V J CH		CCCZ 813904
C-2	Ceramic Capacitor, 0.01 $\mu$ F 50V K YB		CKBZ 811035
C-4	Ceramic Capacitor, 0.01 $\mu$ F 50V K YB		CKBZ 811035
C-5	Ceramic Capacitor, 0.01 $\mu$ F 50V K YB		CKBZ 811035
C-6	Ceramic Capacitor, 0.01 $\mu$ F 50V K YB		CKBZ 811035
C-7	Ceramic Capacitor, 0.0047 $\mu$ F 50V K YB		CKBZ 814725
C-8	Ceramic Capacitor, 100pF 50V K SL		CCGZ 811015
C-9	Ceramic Capacitor, 0.001 $\mu$ F 50V K YB		CKBZ 811025
C-10	Ceramic Capacitor, 0.0047 $\mu$ F 50V K YB		CKBZ 814725
C-11	Ceramic Capacitor, 0.0047 $\mu$ F 50V K YB		CKBZ 814725
C-12	Ceramic Capacitor, 0.0047 $\mu$ F 50V K YB		CKBZ 814725
C-13	Ceramic Capacitor, 0.0047 $\mu$ F 50V K YB		CKBZ 814725
C-14	Electrolytic Capacitor, 33 $\mu$ F 10V Z		CELZ 113300
C-15	Ceramic Capacitor, 0.01 $\mu$ F 50V K YB		CKBZ 811035
C-16	Ceramic Capacitor, 0.01 $\mu$ F 50V K YB		CKBZ 811035
C-17	Mylar Capacitor, 0.01 $\mu$ F 50V K		QMZ811035
C-18	Mylar Capacitor, 0.039 $\mu$ F 50V K		QMZ813935
C-19	Ceramic Capacitor, 0.022 $\mu$ F 50V Z ZF		CKCZ 812230
C-20	Ceramic Capacitor, 0.022 $\mu$ F 50V Z ZF		CKCZ 812230
C-21	Ceramic Capacitor, 0.022 $\mu$ F 50V Z ZF		CKCZ 812230
C-22	Ceramic Capacitor, 0.022 $\mu$ F 50V Z ZF		CKCZ 812230
C-23	Mylar Capacitor, 0.022 $\mu$ F 50V K		QMZ812235
C-24	Ceramic Capacitor, 100pF 50V K CH		CKBZ 811015
C-25	Mylar Capacitor, 0.039 $\mu$ F 50V K		QMZ813935
C-26	Mylar Capacitor, 0.039 $\mu$ F 50V K		QMZ813935
C-27	Mylar Capacitor, 0.039 $\mu$ F 50V K		QMZ813935
C-28	Ceramic Capacitor, 0.022 $\mu$ F 50V Z ZF		CKCZ 812230
C-29	Mylar Capacitor, 0.039 $\mu$ F 50V K		QMZ813935
C-30	Mylar Capacitor, 0.039 $\mu$ F 50V K		QMZ813935
C-31	Mylar Capacitor, 0.039 $\mu$ F 50V K		QMZ813935
C-32	Ceramic Capacitor, 5pF 50V D CH		CCCZ 815092
C-33	Ceramic Capacitor, 0.022 $\mu$ F 50V Z ZF		CKCZ 812230
C-34	Ceramic Capacitor, 0.022 $\mu$ F 50V Z ZF		CKCZ 812230
C-35	Electrolytic Capacitor, 1 $\mu$ F 50V Z		CELZ 811090
C-36	Ceramic Capacitor, 5pF 50V D CH		CCCZ 815092
C-37	Ceramic Capacitor, 10pF 50V J CH		CCCZ 811004
C-38	Ceramic Capacitor, 330pF 50V K UJ		CCUZ 813315
C-39	Solid Aluminum Electrolytic Capacitor, 0.1 $\mu$ F 16V M		CAAZ311086
C-40	Mylar Capacitor, 0.039 $\mu$ F 50V K		QMZ813935
C-41	Ceramic Capacitor, 0.022 $\mu$ F 50V Z ZF		CKCZ 812230
C-42	Electrolytic Capacitor, 10 $\mu$ F 16V Z		CELZ 311000
C-43	Electrolytic Capacitor, 10 $\mu$ F 16V Z		CELZ 311000
C-44	Electrolytic Capacitor, 4.7 $\mu$ F 25V Z		CELZ 514790
C-45	Ceramic Capacitor, 47pF 50V J CH		CCCZ 814704
C-46	Ceramic Capacitor, 0.01 $\mu$ F 50V K YB		CKBZ 811035
C-47	Electrolytic Capacitor, 22 $\mu$ F 16V Z		CELZ 312200
C-49	Electrolytic Capacitor, 47 $\mu$ F 10V Z		CELZ 114700
C-50	Electrolytic Capacitor, 47 $\mu$ F 10V Z		CELZ 114700
C-51	Mylar Capacitor, 0.022 $\mu$ F 50V K		QMZ812235
C-52	Solid Aluminum Electrolytic Capacitor, 0.1 $\mu$ F 16V M		CAAZ311086
C-53	Ceramic Capacitor, 0.01 $\mu$ F 50V K YB		CKBZ 811035
C-54	Ceramic Capacitor, 22pF 50V J CH		CCCZ 812204
C-55	Electrolytic Capacitor, 2.2 $\mu$ F 25V Z		CELZ 512290

The first code indicates tolerance of capacitance; C =  $\pm 0.25\mu\text{F}$ , D =  $\pm 0.5\mu\text{F}$ , F =  $\pm 1\mu\text{F}$ , G =  $\pm 2\%$ , J =  $\pm 5\%$ , K =  $\pm 10\%$ , M =  $\pm 20\%$ , Z =  $+80\% -20\%$

REF. NO.	DESCRIPTION	RS. PART NO.	MFRS PART NO.
C-57	Ceramic Capacitor, 0.022 $\mu\text{F}$ 50V Z ZF		CKCZ812230
C-58	Electrolytic Capacitor, 1 $\mu\text{F}$ 50V Z		CELZ 811090
C-59	Electrolytic Capacitor, 47 $\mu\text{F}$ 10V Z		CELZ 114700
C-60	Solid Aluminum Electrolytic Capacitor, 0.1 $\mu\text{F}$ 16V M		CAAZ311086
C-61	Mylar Capacitor, 0.033 $\mu\text{F}$ 50V K		CQMZ813335
C-62	Mylar Capacitor, 0.047 $\mu\text{F}$ 50V K		CQMZ814735
C-63	Electrolytic Capacitor, 10 $\mu\text{F}$ 16V Z		CELZ 311000
C-64	Mylar Capacitor, 0.068 $\mu\text{F}$ 50V K		CQMZ816835
C-66	Electrolytic Capacitor, 47 $\mu\text{F}$ 10V Z		CELZ 114700
C-67	Electrolytic Capacitor, 4.7 $\mu\text{F}$ 25V Z		CELZ 514790
C-68	Electrolytic Capacitor, 2.2 $\mu\text{F}$ 25V Z		CELZ 512290
C-69	Solid Aluminum Electrolytic Capacitor, 0.1 $\mu\text{F}$ 16V M		CAAZ311086
C-71	Mylar Capacitor, 0.068 $\mu\text{F}$ 50V K		CQMZ816835
C-72	Mylar Capacitor, 0.022 $\mu\text{F}$ 50V K		CQMZ812235
C-73	Mylar Capacitor, 0.1 $\mu\text{F}$ 50V K		CQMZ811045
C-74	Mylar Capacitor, 0.01 $\mu\text{F}$ 50V K		CQMZ811035
C-75	Mylar Capacitor, 0.1 $\mu\text{F}$ 50V K		CQMZ811045
C-76	Electrolytic Capacitor, 47 $\mu\text{F}$ 10V Z		CELZ 114700
C-77	Solid Aluminum Electrolytic Capacitor, 0.1 $\mu\text{F}$ 16V M		CAAZ311086
C-78	Solid Aluminum Electrolytic Capacitor, 0.1 $\mu\text{F}$ 16V M		CAAZ311086
C-79	Electrolytic Capacitor, 0.47 $\mu\text{F}$ 50V Z		CELZ 814780
C-80	Mylar Capacitor, 0.01 $\mu\text{F}$ 50V K		CQMZ811035
C-81	Electrolytic Capacitor, 220 $\mu\text{F}$ 16V Z		CELZ 312210
C-82	Mylar Capacitor, 0.022 $\mu\text{F}$ 50V K		CQMZ812235
C-84	Electrolytic Capacitor, 1 $\mu\text{F}$ 50V Z		CELZ 811090
C-85	Mylar Capacitor, 0.039 $\mu\text{F}$ 50V K		CQMZ813935
C-86	Mylar Capacitor, 0.022 $\mu\text{F}$ 50V K		CQMZ812235
C-87	Electrolytic Capacitor, 2.2 $\mu\text{F}$ 25V Z		CELZ 512290
C-88	Tantalum Capacitor, 4.7 $\mu\text{F}$ 10V M		CSEZ 114796
C-89	Electrolytic Capacitor, 33 $\mu\text{F}$ 16V Z		CELZ 313300
C-90	Ceramic Capacitor, 22pF 50V J CH		CCCZ 812204
C-91	Mylar Capacitor, 0.1 $\mu\text{F}$ 50V K		CQMZ811045
C-92	Electrolytic Capacitor, 33 $\mu\text{F}$ 16V Z		CELZ 313300
C-93	Ceramic Capacitor, 68pF 50V J CH		CCCZ 816804
C-94	Electrolytic Capacitor, 470 $\mu\text{F}$ 16V Z		CELZ 314710
C-95	Electrolytic Capacitor, 470 $\mu\text{F}$ 16V Z		CELZ 314710
C-96	Mylar Capacitor, 0.22 $\mu\text{F}$ 50V K		CQMZ811045
C-97	Electrolytic Capacitor, 4.7 $\mu\text{F}$ 25V Z		CELZ 514790
C-98	Electrolytic Capacitor, 1 $\mu\text{F}$ 50V Z		CELZ 811090
C-99	Electrolytic Capacitor, 10 $\mu\text{F}$ 16V Z		CELZ 311000
C-100	Ceramic Capacitor, 0.022 $\mu\text{F}$ 50V Z ZF		CKCZ812230
C-101	Electrolytic Capacitor, 100 $\mu\text{F}$ 10V Z		CELZ 111010
C-102	Electrolytic Capacitor, 220 $\mu\text{F}$ 10V Z		CELZ 112210
C-103	Electrolytic Capacitor, 470 $\mu\text{F}$ 10V Z		CELZ 114710
C-104	Electrolytic Capacitor, 330 $\mu\text{F}$ 10V Z		CELZ 113310
C-105	Ceramic Capacitor, 0.022 $\mu\text{F}$ 50V Z ZF		CKCZ812230
C-106	Ceramic Capacitor, 0.022 $\mu\text{F}$ 50V Z ZF		CKCZ812230
C-107	Electrolytic Capacitor, 1000 $\mu\text{F}$ 16V Z		CELZ 311020
C-109	Ceramic Capacitor, 0.022 $\mu\text{F}$ 50V Z ZF		CKCZ812230
C-110	Solid Aluminum Electrolytic Capacitor, 0.1 $\mu\text{F}$ 16V M		CAAZ311086
C-111	Ceramic Capacitor, 18pF 50V J CH		CCCZ 811804
C-112	Ceramic Capacitor, 18pF 50V J CH		CCCZ 811804
C-113	Ceramic Capacitor, 0.001 $\mu\text{F}$ 50V K YB		CKBZ811025
C-114	Ceramic Capacitor, 0.001 $\mu\text{F}$ 50V K YB		CKBZ811025

The second code indicates variation of capacitance against temperature; YA = ±5%, YB = ±10%, YD = +20 -30%, YE = +20 -50%, YF = +30 -80%, (-25 ~ +85°C), ZF = +30 -80% (-10 ~ +70°C), CH = 0±60ppm/°C, RH = -220ppm/°C±60ppm/°C, TH = -4700ppm/°C±60ppm/°C, SL = +350ppm/°C ~ -1000ppm/°C, UJ = -750ppm/°C±120ppm/°C

REF. NO.	DESCRIPTION	RS. PART NO.	MFRS PART NO.
C-115	Ceramic Capacitor, 100pF 50V K CH		CCCZ 811015
C-116	Ceramic Capacitor, 10pF 50V J CH		CCCZ 811004
C-117	Ceramic Capacitor, 1pF 50V C CH		CCCZ 811091
C-118	Ceramic Capacitor, 0.022μF 50V Z ZF		CKCZ 812230
C-120	Electrolytic Capacitor, 10μF 16V Z		CELZ 311000
C-121	Mylar Capacitor, 0.039μF 50V K		CQMZ813935
C-122	Ceramic Capacitor, 47pF 50V J CH		CCCZ 814704
C-123	Ceramic Capacitor, 47pF 50V J CH		CCCZ 814704
C-124	Ceramic Capacitor, 0.01μF 50V K YB		CKBZ 811035
C-125	Ceramic Capacitor, 270pF 50V K SL		CCGZ 812715
C-126	Electrolytic Capacitor, 1μF 50V Z		CELZ 811090
C-127	Ceramic Capacitor, 470pF 50V K SL		CCGZ 814715
C-128	Ceramic Capacitor, 220pF 50V K SL		CCGZ 812215
C-129	Ceramic Capacitor, 0.01μF 50V K YB		CKBZ 811035
C-130	Ceramic Capacitor, 10pF 50V J CH		CCCZ 811004
C-131	Mylar Capacitor, 0.01μF 50V K		CQMZ811035
C-133	Mylar Capacitor, 0.1μF 50V K		CQMZ811045
C-134	Mylar Capacitor, 0.1μF 50V K		CQMZ811045
C-135	Electrolytic Capacitor, 220μF 10V Z		CELZ 112210
C-136	Ceramic Capacitor, 470pF 50V K SL		CCGZ 814715
C-137	Ceramic Capacitor, 220pF 50V K SL		CCGZ 812215
C-138	Ceramic Capacitor, 0.01μF 50V K YB		CKBZ 811035
C-139	Ceramic Capacitor, 10pF 50V J CH		CCCZ 811004
C-140	Tantalum Capacitor, 10μF 6.3V M		CSEZ 901006
C-141	Tantalum Capacitor, 10μF 6.3V M		CSEZ 901006
C-142	Ceramic Capacitor, 68pF 50V J CH		CCCZ 816804
C-143	Ceramic Capacitor, 7pF 50V D CH		CCCZ 817092
C-146	Ceramic Capacitor, 0.022μF 50V Z ZF		CKCZ 812230
C-147	Ceramic Capacitor, 470pF 50V K SL		CCGZ 814715
C-148	Ceramic Capacitor, 220pF 50V K SL		CCGZ 812215
C-149	Ceramic Capacitor, 0.01μF 50V K YB		CKBZ 811035
C-150	Ceramic Capacitor, 10pF 50V J CH		CCCZ 811004
C-151	Ceramic Capacitor, 0.01μF 50V K YB		CKBZ 811035
C-152	Ceramic Capacitor, 0.01μF 50V K YB		CKBZ 811035
C-153	Mylar Capacitor, 0.047μF 50V K		COMZ814735
C-154	Ceramic Capacitor, 15pF 50V J CH		CCCZ 811504
C-155	Ceramic Capacitor, 1pF 50V C CH		CCCZ 811091
C-156	Ceramic Capacitor, 0.022μF 50V Z ZF		CKCZ 812230
C-157	Mylar Capacitor, 0.039μF 50V K		CQMZ813935
C-158	Tantalum Capacitor, 1μF 25V M		CSEZ 511096
C-159	Ceramic Capacitor, 0.0047μF 50V K YB		CKBZ 814725
C-160	Ceramic Capacitor, 0.0047μF 50V K YB		CKBZ 814725
C-163	Ceramic Capacitor, 47pF 50V J CH		CCCZ 814704
C-164	Ceramic Capacitor, 68pF 50V J CH		CCCZ 816804
C-165	Ceramic Capacitor, 220pF 50V K CH		CCCZ 812215
C-166	Ceramic Capacitor, 0.0047μF 50V K YB		CKBZ 814725
C-167	Ceramic Capacitor, 390pF 50V K UJ		CCUZ 813915
C-168	Ceramic Capacitor, 0.5pF 50V C CH		CCCZ 815081
C-169	Mylar Capacitor, 0.047μF 50V K		CQMZ814735
C-170	Ceramic Capacitor, 470pF 50V K UJ		CCUZ 814715
C-172	Ceramic Capacitor, 0.0047μF 50V K YB		CKBZ 814725
C-173	Ceramic Capacitor, 180pF 50V K CH		CCCZ 811815
C-174	Ceramic Capacitor, 56pF 50V J CH		CCCZ 815604
C-175	Mylar Capacitor, 0.1μF 50V K		CQMZ811045

REF. NO.	DESCRIPTION	RS. PART NO.	MFRS PART NO.
C-176	Ceramic Capacitor, 56pF 50V J CH		CCCZ 815604
C-177	Ceramic Capacitor, 0.0047 $\mu$ F 50V K YB		CKBZ814725
C-178	Ceramic Capacitor, 0.0047 $\mu$ F 50V K YB		CKBZ814725
C-179	Tantalum Capacitor, 2.2 $\mu$ F 25V M		CSEZ 512296
C-183	Ceramic Capacitor, 0.0047 $\mu$ F 50V K YB		CKBZ814725
C-184	Ceramic Capacitor, 120pF 50V K CH		CCCZ 811215
C-185	Ceramic Capacitor, 0.0047 $\mu$ F 50V K YB		CKBZ814725
C-186	Ceramic Capacitor, 0.0047 $\mu$ F 50V K YB		CKBZ814725
C-187	Ceramic Capacitor, 0.0047 $\mu$ F 50V K YB		CKBZ814725
C-188	Mylar Capacitor, 0.047 $\mu$ F 50V K		QQMZ814735
C-189	Ceramic Capacitor, 0.0047 $\mu$ F 50V K YB		CKBZ814725
C-190	Ceramic Capacitor, 0.01 $\mu$ F 50V K YB		CKBZ811035
C-192	Ceramic Capacitor, 0.01 $\mu$ F 50V K YB		CKBZ811035
C-193	Ceramic Capacitor, 0.022 $\mu$ F 50V Z ZF		CKCZ812230
C-194	Mylar Capacitor, 0.039 $\mu$ F 50V K		QQMZ813935
C-195	Ceramic Capacitor, 0.01 $\mu$ F 50V K YB		CKBZ811035
C-196	Ceramic Capacitor, 0.022 $\mu$ F 50V Z ZF		CKCZ812230
C-197	Ceramic Capacitor, 0.022 $\mu$ F 50V Z ZF		CKCZ812230
C-198	Mylar Capacitor, 0.1 $\mu$ F 50V K		QQMZ811045
C-199	Electrolytic Capacitor, 1 $\mu$ F 50V Z		CELZ 811090
C-200	Mylar Capacitor, 0.01 $\mu$ F 50V K		QQMZ811035
C-202	Ceramic Capacitor, 0.022 $\mu$ F 50V Z ZF		CKCZ812230
C-203	Ceramic Capacitor, 0.022 $\mu$ F 50V Z ZF		CKCZ812230
C-204	Ceramic Capacitor, 0.01 $\mu$ F 50V K YB		CKBZ811035
C-205	Ceramic Capacitor, 0.01 $\mu$ F 50V K YB		CKBZ811035
C-206	Ceramic Capacitor, 0.022 $\mu$ F 50V Z ZF		CKCZ812230
C-207	Ceramic Capacitor, 0.01 $\mu$ F 50V K YB		CKBZ811035
C-208	Ceramic Capacitor, 0.01 $\mu$ F 50V K YB		CKBZ811035
C-209	Ceramic Capacitor, 0.01 $\mu$ F 50V K YB		CKBZ811035
C-210	Mylar Capacitor, 0.01 $\mu$ F 50V K		QQMZ811035
C-211	Electrolytic Capacitor, 2.2 $\mu$ F 25V Z		CELZ 512290
C-213	Ceramic Capacitor, 0.1 $\mu$ F 50V Z ZF		CKCZ811040
C-214	Ceramic Capacitor, 0.01 $\mu$ F 50V K YB		CKBZ811035
C-215	Ceramic Capacitor, 0.022 $\mu$ F 50V Z ZF		CKCZ812230
C-216	Ceramic Capacitor, 0.022 $\mu$ F 50V Z ZF		CKCZ812230
C-217	Ceramic Capacitor, 0.022 $\mu$ F 50V Z ZF		CKCZ812230
C-218	Electrolytic Capacitor, 4.7 $\mu$ F 25V Z		CELZ 514790
C-219	Ceramic Capacitor, 0.022 $\mu$ F 50V Z ZF		CKCZ812230
C-220	Ceramic Capacitor, 0.022 $\mu$ F 50V Z ZF		CKCZ812230
C-221	Ceramic Capacitor, 0.022 $\mu$ F 50V Z ZF		CKCZ812230
C-222	Ceramic Capacitor, 0.1 $\mu$ F 50V Z ZF		CKCZ811040
C-223	Ceramic Capacitor, 0.022 $\mu$ F 50V Z ZF		CKCZ812230
C-227	Ceramic Capacitor, 0.022 $\mu$ F 50V Z ZF		CKCZ812230
C-228	Ceramic Capacitor, 0.022 $\mu$ F 50V Z ZF		CKCZ812230
C-231	Mylar Capacitor, 0.047 $\mu$ F 50V K		QQMZ814735
C-233	Ceramic Capacitor, 0.1 $\mu$ F 50V Z ZF		CKCZ811040
C-236	Ceramic Capacitor, 33pF 50V J CH		CCCZ 813304
C-239	Ceramic Capacitor, 0.1 $\mu$ F 50V Z ZF		CKCZ811040
C-240	Mylar Capacitor, 0.01 $\mu$ F 50V K		QQMZ811035
C-241	Mylar Capacitor, 0.047 $\mu$ F 50V K		QQMZ814735
C-242	Ceramic Capacitor, 47pF 50V J CH		CCCZ 814704
C-244	Ceramic Capacitor, 33pF 50V J CH		CCCZ 813304
C-245	Mylar Capacitor, 0.047 $\mu$ F 50V Z		QQMZ814735
C-248	Ceramic Capacitor, 0.022 $\mu$ F 50V Z ZF		CKCZ812230
C-249	Ceramic Capacitor, 0.01 $\mu$ F 50V Z ZF		CKFZ811030
C-250	Ceramic Capacitor, 0.01 $\mu$ F 50V Z ZF		CKFZ811030
C-251	Ceramic Capacitor, 0.01 $\mu$ F 50V Z ZF		CKFZ811030



REF. NO.	DESCRIPTION	RS. PART NO.	MFRS PART NO.
C-255	Ceramic Capacitor 0.0047 $\mu$ F 50V K YB		CKBZ814725
C-256	Ceramic Capacitor, 150pF 50V J CH		CCCZ 811514
C-257	Ceramic Capacitor, 27pF 50V J CH		CCCZ 812704
C-258	Ceramic Capacitor, 15pF 50V J CH		CKBZ811504
C-259	Mylar Capacitor, 0.022 $\mu$ F 50V K		CQMZ812235
C-263	Ceramic Capacitor, 0.001 $\mu$ F 50V K YB		CKBZ811025
C-401	Mylar Capacitor, 0.047 $\mu$ F 50V K		CQMZ814735
C-405	Ceramic Capacitor, 0.01 $\mu$ F 50V Z ZF		CKCZ 811030
C-406	Ceramic Capacitor, 0.01 $\mu$ F 50V Z ZF		CKCZ 811030
C-408	Ceramic Capacitor, 0.01 $\mu$ F 50V Z ZF		CKCZ 811030
C-413	Ceramic Capacitor, 0.1 $\mu$ F 50V Z ZF		CKCZ 811040
C-414	Ceramic Capacitor, 0.1 $\mu$ F 50V Z ZF		CKCZ 811040
C-415	Ceramic Capacitor, 0.001 $\mu$ F 50V K YB		CKBZ811025
C-416	Ceramic Capacitor, 0.001 $\mu$ F 50V K YB		CKBZ811025
C-418	Ceramic Capacitor, 0.01 $\mu$ F 50V Z ZF		CKCZ 811030
C-419	Ceramic Capacitor, 0.01 $\mu$ F 50V Z ZF		CKCZ 811030
C-601	Ceramic Capacitor, 8pF 50V D CH		CCCZ 818092
C-602	Ceramic Capacitor, 0.0047 $\mu$ F 50V K YB		CKBZ814725
C-603	Ceramic Capacitor, 0.01 $\mu$ F 50V K YB		CKBZ811035
C-604	Ceramic Capacitor, 39pF 50V J CH		CCCZ 813904
C-605	Solid Aluminum Electrolytic Capacitor, 0.1 $\mu$ F 16V M		CAAZ311086
C-606	Ceramic Capacitor, 0.01 $\mu$ F 50V K YB		CKBZ811035
CT-1	Trimmer Capacitor, 20pF CV-028 (or CV-020)		CCVY028004
CT-2	Trimmer Capacitor, 20pF CV-028 (or CV-020)		CCVY028004
CT-3	Trimmer Capacitor, 20pF CV-028 (or CV-020)		CCVY028004
CT-4	Trimmer Capacitor, 20pF CV-028 (or CV-020)		CCVY028004
CT-5	Trimmer Capacitor, 20pF CV-028 (or CV-020)		CCVY028004
CT-6	Trimmer Capacitor, 20pF CV-028 (or CV-020)		CCVY028004
CT-7	Trimmer Capacitor, 20pF CV-028 (or CV-020)		CCVY028004
RR-1	Compound Parts, 4.7K ohm HA-004 (or HA-005 HA-007)	C-0792	HHAY004001
CC-1	Compound Parts, 0.01 $\mu$ F HA-003	C-0793	HHAY003001
CC-2	Compound Parts, 0.01 $\mu$ F HA-003	C-0793	HHAY003001
<b>DIODES</b>			
D-1	Diode, 1S2473		DDAY048014
D-3	Diode, 1S2473		DDAY048014
D-4	Diode, 1S2473		DDAY048014
D-5	Diode, 1S2473		DDAY048014
D-6	Diode, 1S2473		DDAY048014
D-7	Diode, 1S2473		DDAY048014
D-8	Diode, 1S2473	DX-0299	DDAY048012
D-9	Diode, 1S2473	DX-0299	DDAY048012
D-10	Diode, 1N60P	DX-0162	DDAY001023
D-11	Diode, 1N60P	DX-0162	DDAY001023
D-12	Diode, 1S2473		DDAY048014
D-13	Diode, 1S2473	DX-0162	DDAY048014
D-14	Diode, 1S2473	DX-0162	DDAY048014
D-15	Diode, 1N60P		DDAY001023
D-16	Diode, 1N60P		DDAY001023
D-17	Diode, 1S2473		DDAY048014

REF. NO.	DESCRIPTION	RS. PART NO.	MFRS PART NO.
D-18	Diode, 1S2473 (or 1S2473K)		DDAY048001
D-19	Diode, 1S2473 (or 1S2473K)		DDAY048001
D-20	Diode, 1S2473		DDAY048001
D-21	Diode, 1S2473		DDAY048001
D-22	Diode, 1S2473		DDAY048001
D-24	Zener Diode, CZ-092 9.2V	DX-0087	DDAY010002
D-25	Zener Diode, BZ-075 7.5V	DX-0748	DDAY009005
D-26	Zener Diode, YZ-037 3.7V		DDAY087002
D-27	Diode, SR1K-2	DX-0475	DDAY002002
D-28	Zener Diode, CZ-092 9.2V	DX-0087	DDAY010002
D-29	Diode, 1S2473		DDAY048014
D-30	Diode, 1S2473		DDAY048014
D-31	Zener, WZ-061 6.1V	DX-0530	DDAY008019
D-32	Zener, WZ-061 6.1V	DX-0530	DDAY008018
D-33	Diode, 1S2473		DDAY048014
D-34	Diode, 1S2473		DDAY048014
D-35	Diode, 1S2473		DDAY048014
D-36	Diode, 1S2473		DDAY048014
D-37	Diode, 1S2473		DDAY048014
D-38	Diode, 1S2473	DX-0299	DDAY048012
D-39	Diode, 1S2473		DDAY048014
D-40	Diode, 1S2473		DDAY048014
D-41	Varicap, 1S2687D	DX-0749	DDAY067001
D-43	Varicap, 1S2687D	DX-0749	DDAY067001
D-44	Zener Diode, CZ-092 9.2V	DX-0087	DDAY010002
D-45	Varicap, 1S2687D	DX-0749	DDAY067001
D-46	Diode, 1S2473		DDAY048014
D-47	Diode, 1S2473		DDAY048014
D-50	Diode, 1N60P	DX-0162	DDAY001023
D-51	Varistor, MV-1Y	DX-0750	DDFY020001
D-52	Varistor, MV-1Y	DX-0750	DDFY020001
D-53	Diode, 1S2473		DDAY048014
D-54	Diode, SR1K-2	DX-0475	DDAY002002
D-56	Diode, 1S2473	DX-0299	DDAY048012
D-57	Diode, 1N60P	DX-0162	DDAY001002
D-58	Diode, 1S2473		DDAY048014
D-59	Diode, 1N60P	DX-0162	DDAY001023
D-61	Diode, 1S2473	DX-0299	DDAY048012
D-62	Diode, 1S2473 (or 1S2473K)		DDAY048001
D-64	Diode, 1S2473 (or 1S2473K)		DDAY048001
D-65	Diode, 1S2473 (or 1S2473K)		DDAY048001
D-66	Diode, 1S2473 (or 1S2473K)		DDAY048001
D-67	Diode, 1S2473 (or 1S2473K)		DDAY048001
D-68	Diode, 1S2473 (or 1S2473K)		DDAY048001
D-401	LED, TLR-321	L-0776	DDAY078001
D-403	LED, LR0702R	L-0777	DDAY073001
D-404	LED, LR0702R	L-0777	DDAY073001
D-405	LED, LR0702R	L-0777	DDAY073001
D-601	Diode, 1N60P	DX-0955	DDAY001002
D-602	Diode, 1N60P	DX-0955	DDAY001002
D-603	Diode, 1S2473 (or 1S2473K)	DX-0299	DDAY048001

REF. NO.	DESCRIPTION	RS. PART NO.	MFRS PART NO.
<b>FET'S</b>			
FET-1	FET, 3SK45-B		DDCY104001
FET-2	FET, JF1033 (Red) (or 2SK19-BL)		DDCY202003
FET-3	FET, 2SK68A-M (or 2SK68-M)		DDCY009002
FET-4	FET, 3SK45B-09		DDCY104003
FET-5	FET, 2SK68A-M (or 2SK68-M)		DDCY009002
FET-6	FET, JF1033 (Red) (or 2SK19-BL)		DDCY202003
FET-7	FET, 3SK45-B		DDCY104001
FET-601	FET, JF1033		DDCY202002
<b>INTEGRATED CIRCUITS</b>			
IC-1	IC, $\mu$ PC577H	MX-3389	DDEY064001
IC-2	IC, MC1496N	MX-3369	DDEY020001
IC-3	IC, $\mu$ PC592H2	MX-3370	DDEY097001
IC-4	IC, $\mu$ PC1156H	MX-3372	DDEY091001
IC-5	IC, UHIC-005	MX-3379	DDEY082001
IC-6	IC, $\mu$ PC78L05	MX-3198	DDEY093001
IC-7	IC, $\mu$ PD858C	MX-3399	DDEY055001
<b>COILS</b>			
L-1	Coil, LA-029 23.5 MHz	CA-3272	LLAY029001
L-2	Coil, LA-155 23.5 MHz	CA-3747	LLAY 155001
L-3	Coil, LA-152 27 MHz	CA-3746	LLAY 152001
L-4	Coil, LA-156 27 MHz	CA-3748	LLAY 156001
L-5	Coil, LA-179 7.8 MHz	CA-3751	LLAY 179001
L-7	Coil, LA-038 7.8 MHz	CA-3414	LLAY 038001
L-8	Coil, LA-096 7.8 MHz	CA-3424	LLAY 096001
L-9	Micro Inductor, LZ-012 470 $\mu$ H	C-0787	LLZY 012004
L-10	Micro Inductor, LZ-015 56mH (or LZ-019)	C-0788	LLZY 015022
L-11	Micro Inductor, LZ-015 68mH (or LZ-109)	C-0789	LLZY 015023
L-12	Micro Inductor, LZ-012 470 $\mu$ H	C-0787	LLZY 012004
L-13	Micro Inductor, LZ-012 470 $\mu$ H	C-0787	LLZY 012004
L-14	Micro Inductor, LZ-012 470 $\mu$ H	C-0787	LLZY 012004
L-16	Coil, LA-195 34.195 MHz	CA-3750	LLAY 195001
L-17	Coil, LA-191 34.195 MHz	CA-3753	LLAY 191001
L-18	Micro Inductor, LZ-012 470 $\mu$ H	C-0708	LLZY 012004
L-19	Micro Inductor, LZ-012 100 $\mu$ H	C-0786	LLZY 012001
L-20	Micro Inductor, LZ-012 470 $\mu$ H	C-0708	LLZY 012004
L-21	Micro Inductor, LZ-012 470 $\mu$ H	C-0708	LLZY 012004
L-22	Micro Inductor, LZ-012 470 $\mu$ H	C-0708	LLZY 012004
L-23	Micro Inductor, LZ-012 470 $\mu$ H	C-0708	LLZY 012004
L-24	Coil, LA-190 33.855 MHz	CA-3752	LLAY 190001
L-25	Micro Inductor, LZ-012 470 $\mu$ H	C-0787	LLZY 012004
L-27	Coil, LC-018 0.28 $\mu$ H	CA-3409	LLCY 018001
L-28	Coil, LE-051 0.4 $\mu$ H (or LE-068)	CA-3760	LLEY 051001
L-29	Coil, LE-051 0.4 $\mu$ H (or LE-068)	CA-3760	LLEY 051001
L-30	Coil, LC-019 0.37 $\mu$ H	CA-3639	LLCY 019001
L-31	Coil, LD-018 0.89 $\mu$ H	CA-3757	LLDY 018001
L-32	Coil, LC-018 0.28 $\mu$ H	CA-3409	LLCY 018001
L-33	Coil, LD-018 0.89 $\mu$ H	CA-3757	LLDY 018001
L-34	Coil, LD-018 0.48 $\mu$ H	CA-3757	LLDY 018001

REF. NO.	DESCRIPTION	RS. PART NO.	MFRS PART NO.
L-35	Coil, LD-057 19 $\mu$ H (or LD-097)	CA-3758	LLDY057001
L-36	Coil, LD-057 19 $\mu$ H (or LD-097)	CA-3758	LLDY057001
L-37	Coil, LA-157 27 MHz	CA-3749	LLAY157001
L-38	Micro Inductor, LZ-012 470 $\mu$ H	C-0787	LLZY012004
L-39	Coil, LA-038 7.8 MHz	CA-3414	LLAY038001
L-40	Coil, LD-072 Z( $\Omega$ ) = 100	CA-3756	LLDY072001
L-41	Coil, LD-077 Z( $\Omega$ ) = 40	CA-3754	LLDY077001
L-42	Coil, LD-077 Z( $\Omega$ ) = 40	CA-3754	LLDY077001
L-43	Micro Inductor, LZ-002 1 $\mu$ H	C-0785	LLZY002001
L-44	Micro Inductor, LZ-002 1 $\mu$ H	C-0785	LLZY002001
L-45	Micro Inductor, LZ-012 100 $\mu$ H	C-0787	LLZY012001
L-46	Micro Inductor, LZ-001 10 $\mu$ H (or LZ-011)		LLZY001001
L-47	Coil, LE-069 0.29 $\mu$ H		LLEY069001
L-401	Coil, LD-089 9.5 $\mu$ H (or LD-091)		LLDY089001
L-402	Coil, LD-089 9.5 $\mu$ H (or LD-091)		LLDY089001
L-403	Coil, LD-089 9.5 $\mu$ H (or LD-091)		LLDY089001
L-404	Coil, LD-089 9.5 $\mu$ H (or LD-091)		LLDY089001
L-405	Coil, LD-089 9.5 $\mu$ H (or LD-091)		LLDY089001
L-407	Coil, LE-003 7.3 $\mu$ H		LLEY003001
L-408	Coil, LD-013 7.3 $\mu$ H		LLDY013001
<b>RESISTORS</b>			
Tolerance Code J = 5% K = 10%			
R-1	Carbon Film Resistor, 220 ohm 1/8W J	NEB-0149	RFPZ 182214
R-2	Carbon Film Resistor, 10K ohm 1/8W J	NEB-0281	RFPZ 181034
R-3	Carbon Film Resistor, 2.2M ohm 1/8W J	NEB-0454	RFPZ 182254
R-4	Carbon Film Resistor, 5.6K ohm 1/8W J	NEB-0257	RFPZ 185624
R-5	Carbon Film Resistor, 100K ohm 1/8W J	NEB-0371	RFPZ 181044
R-6	Carbon Film Resistor, 22K ohm 1/8W J	NEB-0311	RFPZ 182234
R-8	Carbon Film Resistor, 1K ohm 1/8W J	NEB-0196	RFPZ 181024
R-9	Carbon Film Resistor, 4.7K ohm 1/8W J	NEB-0247	RFPZ 184724
R-10	Carbon Film Resistor, 2.7K ohm 1/8W J	NEB-0224	RFPZ 182724
R-11	Carbon Film Resistor, 5.6K ohm 1/8W J	NEB-0257	RFPZ 185624
R-12	Carbon Film Resistor, 1K ohm 1/8W J	NEB-0196	RFPZ 181024
R-13	Carbon Film Resistor, 1.5K ohm 1/8W J	NEB-0206	RFPZ 181524
R-14	Carbon Film Resistor, 1K ohm 1/8W J	NEB-0196	RFPZ 181024
R-15	Carbon Film Resistor, 220 ohm 1/8W J	NEB-0149	RPBZ 182214
R-16	Carbon Film Resistor, 10K ohm 1/8W J	NEB-0281	RFPZ 181034
R-17	Carbon Film Resistor, 470 ohm 1/8W J	NEB-0169	RFPZ 184714
R-19	Carbon Film Resistor, 1.5K ohm 1/8W J	NEB-0206	RFPZ 181524
R-20	Carbon Film Resistor, 1.5K ohm 1/4W J	NEE-0206	RUBZ141524
R-21	Carbon Film Resistor, 1.5K ohm 1/8W J	NEE-0206	RFPZ 181524
R-22	Carbon Film Resistor, 100 ohm 1/8W J		RFPZ 181014
R-23	Carbon Film Resistor, 1.5K ohm 1/8W J	NEB-0206	RFPZ 181524
R-24	Carbon Film Resistor, 10K ohm 1/8W J	NEB-0281	RFPZ 181034
R-25	Carbon Film Resistor, 47 ohm 1/8W J	NEB-0099	RFPZ 184704
R-26	Carbon Film Resistor, 22K ohm 1/8W J	NEB-0311	RFPZ 182234
R-27	Carbon Film Resistor, 5.6K ohm 1/8W J	NEB-0257	RFPZ 185624
R-28	Carbon Film Resistor, 470 ohm 1/8W J	NEB-0169	RFPZ 184714
R-29	Carbon Film Resistor, 220 ohm 1/4W J	NEB-0149	RUBZ142214
R-30	Carbon Film Resistor, 47K ohm 1/8W J	NEB-0340	RFPZ 184734
R-31	Carbon Film Resistor, 3.3K ohm 1/8W J	NEB-0230	RFPZ 183324
R-32	Carbon Film Resistor, 150 ohm 1/8W J	NEB-0142	RFPZ 181514
R-33	Carbon Film Resistor, 220 ohm 1/8W J	NEB-0149	RFPZ 182214

REF. NO.	DESCRIPTION	RS. PART NO.	MFRS PART NO.
R-34	Carbon Film Resistor, 220K ohm 1/8W J	NEB-0396	RFPZ 182244
R-35	Carbon Film Resistor, 100K ohm 1/8W J	NEB-0371	RFPZ 181044
R-36	Carbon Film Resistor, 470 ohm 1/8W J	NEB-0169	RFPZ 184714
R-37	Carbon Film Resistor, 5.6K ohm 1/8W J	NEB-0303	RFPZ 185624
R-38	Carbon Film Resistor, 820K ohm 1/8W J	NEB-0440	RFPZ 188244
R-39	Carbon Film Resistor, 470K ohm 1/8W J	NEB-0423	RFPZ 184744
R-40	Carbon Film Resistor, 220K ohm 1/8W J	NEB-0396	RFPZ 182244
R-42	Carbon Film Resistor, 56K ohm 1/8W J	NEB-0345	RFPZ 185634
R-43	Carbon Film Resistor, 680K ohm 1/8W J	NEB-0433	RFPZ 186844
R-44	Carbon Film Resistor, 1.5K ohm 1/8W J	NEB-0206	RFPZ 181524
R-45	Carbon Film Resistor, 5.6K ohm 1/8W J	NEB-0257	RFPZ 185624
R-46	Carbon Film Resistor, 330 ohm 1/8W J	NEB-0159	RFPZ 183314
R-47	Carbon Film Resistor, 10K ohm 1/8W J	NEB-0281	RFPZ 181034
R-48	Carbon Film Resistor, 10K ohm 1/8W J	NEB-0281	RFPZ 181034
R-49	Carbon Film Resistor, 10K ohm 1/8W J	NEB-0281	RFPZ 181034
R-50	Carbon Film Resistor, 220K ohm 1/8W J	NEB-0396	RFPZ 182244
R-51	Carbon Film Resistor, 3.3K ohm 1/8W J	NEB-0230	RFPZ 183324
R-52	Carbon Film Resistor, 220 ohm 1/8W J	NEB-0149	RFPZ 182214
R-53	Carbon Film Resistor, 68K ohm 1/8W J	NEB-0371	RFPZ 186834
R-54	Carbon Film Resistor, 10K ohm 1/8W J	NEB-0281	RFPZ 181034
R-55	Carbon Film Resistor, 1K ohm 1/8W J	NEB-0196	RFPZ 181024
R-57	Carbon Film Resistor, 3.3K ohm 1/8W J	NEB-0230	RFPZ 183324
R-58	Carbon Film Resistor, 100K ohm 1/8W J	NEB-0371	RFPZ 181044
R-59	Carbon Film Resistor, 3.3K ohm 1/8W J	NEB-0230	RFPZ 183324
R-60	Carbon Film Resistor, 220 ohm 1/8W J	NEB-0149	RFPZ 182214
R-61	Carbon Film Resistor, 10K ohm 1/8W J	NEB-0281	RFPZ 181034
R-62	Carbon Film Resistor, 270 ohm 1/8W J	NEB-0230	RFPZ 182714
R-63	Carbon Film Resistor, 56 ohm 1/8W J	NEB-0107	RFPZ 185604
R-64	Carbon Film Resistor, 10K ohm 1/8W J	NEB-0281	RFPZ 181034
R-65	Carbon Film Resistor, 220 ohm 1/8W J	NEB-0149	RFPZ 182214
R-66	Carbon Film Resistor, 1.5K ohm 1/8W J	NEB-0206	RFPZ 181524
R-67	Carbon Film Resistor, 220 ohm 1/8W J	NEB-0149	RFPZ 182214
R-68	Carbon Film Resistor, 820 ohm 1/8W J	NEB-0187	RFPZ 188214
R-69	Carbon Film Resistor, 1K ohm 1/8W J	NEB-0196	RFPZ 181024
R-70	Carbon Film Resistor, 10K ohm 1/8W J	NEB-0281	RFPZ 181034
R-71	Carbon Film Resistor, 220 ohm 1/8W J	NEB-0149	RFPZ 182214
R-72	Carbon Film Resistor, 150 ohm 1/8W J	NEB-0149	RFPZ 181514
R-73	Carbon Film Resistor, 220K ohm 1/8W J	NEB-0396	RFPZ 182244
R-74	Carbon Film Resistor, 220 ohm 1/8W J	NEB-0149	RFPZ 182214
R-75	Carbon Film Resistor, 100K ohm 1/8W J	NEB-0371	RFPZ 181044
R-76	Carbon Film Resistor, 10K ohm 1/8W J	NEB-0281	RFPZ 181034
R-77	Carbon Film Resistor, 3.3K ohm 1/8W J	NEB-0230	RFPZ 183324
R-78	Carbon Film Resistor, 56K ohm 1/8W J	NEB-0297	RFPZ 185634
R-80	Carbon Film Resistor, 4.7K ohm 1/4W J	NEE-0247	RUBZ 144724
R-81	Carbon Film Resistor, 10K ohm 1/8W J	NEB-0281	RFPZ 181034
R-82	Carbon Film Resistor, 220K ohm 1/8W J	NEB-0396	RFPZ 182244
R-83	Carbon Film Resistor, 10K ohm 1/8W J	NEB-0281	RFPZ 181034
R-84	Carbon Film Resistor, 4.7K ohm 1/8W J	NEB-0247	RFPZ 184724
R-86	Carbon Film Resistor, 1K ohm 1/8W J	NEB-0196	RFPZ 181024
R-87	Carbon Film Resistor, 10K ohm 1/8W J	NEB-0281	RFPZ 181034
R-88	Carbon Film Resistor, 270K ohm 1/8W J	NEB-0402	RFPZ 182744
R-89	Carbon Film Resistor, 10K ohm 1/8W J	NEB-0281	RFPZ 181034
R-91	Carbon Film Resistor, 4.7K ohm 1/8W J	NEB-0247	RFPZ 184724
R-92	Carbon Film Resistor, 3.3K ohm 1/8W J	NEB-0203	RFPZ 183324
R-93	Carbon Film Resistor, 56K ohm 1/4W J	NEE-0345	RUBZ 145634

REF. NO.	DESCRIPTION	RS. PART NO.	MFRS PART NO.
R-94	Carbon Film Resistor, 220 ohm 1/8W J	NEB-0149	RFPZ 182214
R-95	Carbon Film Resistor, 220 ohm 1/8W J	NEB-0149	RFPZ 182214
R-96	Carbon Film Resistor, 3.3K ohm 1/8W J	NEB-0230	RFPZ 183324
R-97	Carbon Film Resistor, 10 ohm 1/8W J	NEB-0063	RFPZ 181004
R-98	Carbon Film Resistor, 10K ohm 1/8W J	NEB-0281	RFPZ 181034
R-100	Carbon Film Resistor, 1K ohm 1/8W J	NEB-0196	RFPZ 181024
R-101	Carbon Film Resistor, 4.7K ohm 1/8W J	NEB-0247	RFPZ 184724
R-102	Carbon Film Resistor, 2.2K ohm 1/8W J	NEB-0215	RFPZ 182224
R-103	Carbon Film Resistor, 2.2K ohm 1/8W J	NEB-0216	RFPZ 182224
R-104	Carbon Film Resistor, 100K ohm 1/8W J	NEB-0396	RFPZ 181044
R-105	Carbon Film Resistor, 68 ohm 1/8W J	NEB-0111	RFPZ 186804
R-106	Carbon Film Resistor, 56K ohm 1/8W J	NEB-0345	RFPZ 185634
R-107	Metal Film Resistor, 2.2 ohm 2W K		RSJZ 202295
R-108	Carbon Film Resistor, 270 ohm 1/8W J	NEB-0155	RFPZ 182714
R-109	Metal Film Resistor, 22 ohm 1W K	NFG-0078	RSJZ 102205
R-110	Carbon Film Resistor, 470 ohm 1/8W J	NEB-0169	RFPZ 184714
R-111	Carbon Film Resistor, 390 ohm 1/8W J	NEB-0162	RFPZ 183914
R-112	Metal Film Resistor, 33 ohm 1W K	NFG-0087	RSJZ 103305
R-113	Metal Film Resistor, 150 ohm 1W K	NFG-0142	RSJZ 101515
R-114	Metal Film Resistor, 22 ohm 1W K	NFG-0078	RSJZ 102205
R-115	Carbon Film Resistor, 1K ohm 1/4W J	NEB-0206	RUBZ 141024
R-116	Carbon Film Resistor, 3.3K ohm 1/8W J	NEB-0224	RFPZ 183324
R-117	Carbon Film Resistor, 4.7 K ohm 1/8W J	NEB-0224	RFPZ 184724
R-118	Carbon Film Resistor, 100 ohm 1/8W J	NEB-0132	RFPZ 181014
R-119	Carbon Film Resistor, 100 ohm 1/8W J	NEB-0132	RFPZ 181014
R-120	Carbon Film Resistor, 2.2K ohm 1/8W J	NEB-0216	RFPZ 182224
R-121	Carbon Film Resistor, 5.6K ohm 1/8W J	NEB-0257	RFPZ 185624
R-122	Carbon Film Resistor, 10K ohm 1/8W J	NEB-0303	RFPZ 181034
R-123	Carbon Film Resistor, 1K ohm 1/8W J	NEB-0196	RFPZ 181024
R-124	Carbon Film Resistor, 150K ohm 1/8W J	NEB-0384	RFPZ 181544
R-125	Carbon Film Resistor, 2.7K ohm 1/8W J	NEB-0224	RFPZ 182724
R-126	Carbon Film Resistor, 820 ohm 1/8W J	NEB-0187	RFBZ 188214
R-127	Carbon Film Resistor, 1.5K ohm 1/8W J	NEB-0206	RFPZ 181524
R-128	Carbon Film Resistor, 1.5K ohm 1/8W J	NEB-0206	RFPZ 181524
R-130	Carbon Film Resistor, 1.5K ohm 1/8W J	NEB-0206	RFPZ 181524
R-131	Carbon Film Resistor, 220 ohm 1/8W J	NEB-0149	RFPZ 182214
R-132	Carbon Film Resistor, 100 ohm 1/4W J	NEB-0132	RUBZ 141014
R-133	Carbon Film Resistor, 1K ohm 1/8W J	NEB-0196	RFPZ 181024
R-134	Carbon Film Resistor, 2.2K ohm 1/8W J	NEB-0216	RFPZ 182224
R-135	Carbon Film Resistor, 3.3K ohm 1/8W J	NEB-0230	RFPZ 183324
R-136	Carbon Film Resistor, 22K ohm 1/8W J	NEB-0311	RFPZ 182234
R-137	Carbon Film Resistor, 5.6K ohm 1/8W J	NEB-0257	RFPZ 185624
R-138	Carbon Film Resistor, 5.6K ohm 1/8W J	NEB-0257	RFPZ 185624
R-139	Carbon Film Resistor, 2.2K ohm 1/8W J	NEB-0216	RFPZ 182224
R-140	Carbon Film Resistor, 2.2K ohm 1/8W J	NEB-0216	RFPZ 182224
R-141	Carbon Film Resistor, 220 ohm 1/8W J	NEB-0149	RFPZ 182214
R-142	Carbon Film Resistor, 220 ohm 1/8W J	NEB-0149	RFPZ 182214
R-143	Carbon Film Resistor, 5.6K ohm 1/4W J	NEE-0257	RUBZ 145624
R-144	Carbon Film Resistor, 10K ohm 1/8W J	NEB-0281	RFPZ 181034
R-145	Carbon Film Resistor, 1K ohm 1/8W J	NEB-0196	RFPZ 181024
R-146	Carbon Film Resistor, 2.7K ohm 1/8W J	NEB-0224	RFPZ 182724
R-147	Carbon Film Resistor, 27K ohm 1/8W J	NEB-0316	RFPZ 182734
R-148	Carbon Film Resistor, 47K ohm 1/8W J	NEB-0340	RFPZ 184734
R-149	Carbon Film Resistor, 15K ohm 1/8W J	NEB-0297	RFPZ 181534

REF. NO.	DESCRIPTION	RS. PART NO.	MFRS PART NO.
R-150	Carbon Film Resistor, 33K ohm 1/4W J	NEE-0324	RUBZ143334
R-151	Carbon Film Resistor, 8.2K ohm 1/8W J	NEB-0271	RFPZ 188224
R-152	Carbon Film Resistor, 2.2K ohm 1/8W J	NEB-0216	RFPZ 182224
R-154	Carbon Film Resistor, 220 ohm 1/8W J	NEB-0149	RFPZ 182214
R-155	Carbon Film Resistor, 5.6K ohm 1/4W J	NEE-0257	RUBZ145624
R-156	Carbon Film Resistor, 10K ohm 1/8W J	NEB-0281	RFPZ 181034
R-157	Carbon Film Resistor, 1K ohm 1/8W J	NEB-0196	RFPZ 181024
R-158	Carbon Film Resistor, 15K ohm 1/8W J	NEB-0297	RFPZ 181534
R-159	Carbon Film Resistor, 1K ohm 1/8W J	NEB-0196	RFPZ 181024
R-160	Carbon Film Resistor, 1M ohm 1/8W J	NEB-0445	RFPZ 181054
R-161	Metal Film Resistor, 56 ohm 1W K	NFG-0107	RSJZ 105605
R-162	Carbon Film Resistor, 4.7K ohm 1/8W J	NEB-0247	RFPZ 184724
R-163	Carbon Film Resistor, 5.6K ohm 1/8W J	NEB-0257	RFPZ 185624
R-164	Carbon Film Resistor, 10K ohm 1/8W J	NEB-0281	RFPZ 181034
R-165	Carbon Film Resistor, 1K ohm 1/8W J	NEB-0196	RFPZ 181024
R-166	Carbon Film Resistor, 100K ohm 1/8W J	NEB-0371	RFPZ 181044
R-167	Carbon Film Resistor, 10K ohm 1/8W J	NEB-0281	RFPZ 181034
R-168	Carbon Film Resistor, 100 ohm 1/8W J	NEB-0132	RFPZ 181014
R-169	Carbon Film Resistor, 100 ohm 1/8W J	NEB-0132	RFPZ 181014
R-170	Carbon Film Resistor, 56K ohm 1/8W J	NEB-0345	RFPZ 185634
R-171	Carbon Film Resistor, 10K ohm 1/8W J	NEB-0281	RFPZ 181034
R-172	Carbon Film Resistor, 22K ohm 1/8W J	NEB-0311	RFPZ 182234
R-173	Carbon Film Resistor, 2.2K ohm 1/8W J	NEB-0216	RFPZ 182224
R-174	Carbon Film Resistor, 560 ohm 1/8W J	NEB-0176	RFBZ 185614
R-175	Carbon Film Resistor, 8.2K ohm 1/8W J	NEB-0271	RFPZ 188224
R-179	Carbon Film Resistor, 15 ohm 1/8W J	NEB-0074	RFPZ 181504
R-180	Metal Film Resistor, 100 ohm 1W K		RSJZ 101015
R-181	Metal Film Resistor, 100 ohm 1W K		RSJZ 101015
R-182	Carbon Film Resistor, 10 ohm 1/8W J	NEB-0063	RFPZ 181004
R-183	Carbon Film Resistor, 330 ohm 1/8W J	NEB-0159	RFPZ 183314
R-184	Carbon Film Resistor, 1K ohm 1/8W J	NEB-0196	RFPZ 181024
R-185	Carbon Film Resistor, 1K ohm 1/8W J	NEB-0196	RFPZ 181024
R-186	Carbon Film Resistor, 10 ohm 1/8W J	NEB-0063	RFPZ 181004
R-187	Carbon Film Resistor, 3.3K ohm 1/4W J	NEB-0230	RUBZ143324
R-188	Carbon Film Resistor, 220 ohm 1/8W J	NEB-0149	RFPZ 182214
R-189	Carbon Film Resistor, 100 ohm 1/8W J	NEB-0132	RFPZ 181014
R-190	Carbon Film Resistor, 100K ohm 1/8W J		RFPZ 181044
R-191	Carbon Film Resistor, 150K ohm 1/8W J	NEB-0384	RFPZ 181544
R-192	Carbon Film Resistor, 10K ohm 1/8W J	NEB-0281	RFPZ 181034
R-193	Carbon Film Resistor, 10K ohm 1/8W J	NEB-0281	RFPZ 181034
R-194	Carbon Film Resistor, 56K ohm 1/8W J	NEB-0345	RFPZ 185634
R-195	Carbon Film Resistor, 56K ohm 1/8W J	NEB-0345	RFPZ 185634
R-196	Carbon Film Resistor, 220 ohm 1/8W J	NEB-0149	RFPZ 182214
R-197	Carbon Film Resistor, 33 ohm 1/4W J	NEE-0324	RFBZ 143304
R-199	Carbon Film Resistor, 15 ohm 1/8W J	NEB-0074	RFPZ 181504
R-200	Carbon Film Resistor, 470 ohm 1/8W J	NEB-0169	RFPZ 184714
R-201	Carbon Film Resistor, 10K ohm 1/8W J	NEB-0281	RFPZ 181034
R-202	Carbon Film Resistor, 1K ohm 1/8W J	NEB-0196	RFPZ 181024
R-204	Carbon Film Resistor, 220K ohm 1/4W J		RUBZ142214
R-205	Carbon Film Resistor, 1 ohm 1/4W J		RUBZ141094
R-206	Carbon Film Resistor, 5.6 ohm 1/4W J	NEE-0052	RUBZ145694
R-209	Carbon Film Resistor, 2.2K ohm 1/4W J	NEE-0216	RUBZ142224
R-212	Carbon Film Resistor, 4.7K ohm 1/8W J	NEB-0247	RFPZ 184724
R-213	Carbon Film Resistor, 100K ohm 1/8W J	NEB-0371	RFBZ 181044
R-216	Carbon Film Resistor, 100K ohm 1/4W J	NEE-0371	RUBZ141044

REF. NO.	DESCRIPTION	RS. PART NO.	MFRS PART NO.
R-217	Carbon Film Resistor, 470K ohm 1/4W J	NEE-0169	RUBZ144744
R-218	Carbon Film Resistor, 470 ohm 1/4W J		RPBZ 144714
R-219	Carbon Film Resistor, 47 ohm 1/4W J		RPBZ 144704
R-220	Carbon Film Resistor, 220 ohm 1/8W J		RPBZ 182214
R-221	Carbon Film Resistor, 330 ohm 1/8W J		RFBZ 183314
R-222	Carbon Film Resistor, 560 ohm 1/4W J		RUBZ145614
R-407	Carbon Film Resistor, 22K ohm 1/4W J	NEE-0311	RUBZ142234
R-409	Metal Film Resistor, 22 ohm 2W K		RSJZ 202205
R-601	Carbon Film Resistor, 100K ohm 1/4W J	NEE-0371	RUBZ141044
R-602	Carbon Film Resistor, 220 ohm 1/4W J	NEE-0149	RUBZ142214
R-603	Carbon Film Resistor, 150K ohm 1/4W J	NEE-0384	RUBZ141544
R-604	Carbon Film Resistor, 220 ohm 1/4W J	NEE-0149	RUBZ142214
R-605	Carbon Film Resistor, 1K ohm 1/4W J	NEE-0196	RUBZ141024
<b>SWITCHES</b>			
S-401	Slide Switch, SW-048 (NB) (or SW-056)		SSWY 048001
S-402	Rotary Switch, SR-168 (Mode)		SSRY 168001
S-405	Slide Switch, SW-076 (PA-CB)		SSWY 076001
S-406	Switch on back of VR-405 (POWER)		NA
S-408	Rotary Switch, SR-157 (CH)		SSRY 157001
<b>TRANSISTORS</b>			
TR-1	Transistor, 2SC945A-Q		DDBY224003
TR-2	Transistor, 2SA733-P		DDBY003001
TR-3	Transistor, 2SC945A-Q		DDBY224003
TR-4	Transistor, 2SC945A-Q		DDBY224003
TR-5	Transistor, 2SC1730-L		DDBY269001
TR-6	Transistor, 2SC1675-L (or 2SC1675-K2)		DDBY259001
TR-7	Transistor, 2SC1675-L (or 2SC1675-K2)		DDBY259001
TR-8	Transistor, 2SC1675-L (or 2SC1675-K2)		DDBY259001
TR-9	Transistor, 2SC1675-L (or 2SC1675-K2)		DDBY259001
TR-10	Transistor, 2SC1675-L (or 2SC1675-K2)		DDBY259001
TR-11	Transistor, 2SC945A-Q		DDBY224003
TR-12	Transistor, 2SC945A-Q		DDBY224003
TR-13	Transistor, 2SC945A-Q		DDBY224003
TR-14	Transistor, 2SC945A-Q		DDBY224003
TR-15	Transistor, 2SC945A-Q		DDBY224003
TR-16	Transistor, 2SC945A-Q		DDBY224003
TR-17	Transistor, 2SA733-P		DDBY003001
TR-18	Transistor, 2SC945A-Q		DDBY224003
TR-19	Transistor, 2SA733-P		DDBY003001
TR-20	Transistor, 2SC945A-Q		DDBY224003
TR-21	Transistor, 2SC945A-Q		DDBY224003
TR-22	Transistor, 2SC945A-Q		DDBY224003
TR-23	Transistor, 2SC945A-Q		DDBY224003
TR-24	Transistor, 2SC1419-B		DDBY278001
TR-25	Transistor, 2SC1419-B		DDBY278001
TR-26	Transistor, 2SC945A-Q		DDBY224003
TR-27	Transistor, 2SC1675-L (or 2SC1675-K2)		DDBY259001
TR-28	Transistor, 2SC1675-L (or 2SC1675-K2)		DDBY259001
TR-29	Transistor, 2SC945A-Q		DDBY224003
TR-30	Transistor, 2SC1675-L (or 2SC1675-K2)		DDBY259001



REF. NO.	DESCRIPTION	RS. PART NO.	MFRS PART NO.
TR-31	Transistor, 2SC1675-L (or 2SC1675-K2)		DDBY259001
TR-32	Transistor, 2SC945A-Q		DDBY224003
TR-33	Transistor, 2SC945A-Q		DDBY224003
TR-34	Transistor, 2SC1675-L (or 2SC1675-K2)		DDBY259001
TR-35	Transistor, 2SC458-C		DDBY273001
TR-36	Transistor, 2SC1419-B		DDBY278001
TR-37	Transistor, 2SA719-Q		DDBY011003
TR-38	Transistor, 2SC1675-L (or 2SC1675-K2)		DDBY259001
TR-39	Transistor, 2SC1675-L (or 2SC1675-K2)		DDBY259001
TR-40	Transistor, 2SC1675-L (or 2SC1675-K2)		DDBY259001
TR-41	Transistor, 2SC945A-Q		DDBY224003
TR-42	Transistor, 2SC945A-Q		DDBY224003
TR-43	Transistor, 2SC1307 (1)		DDBY231002
TR-44	Transistor, 2SC1306		DDBY230001
TR-45	Transistor, 2SC1973		DDBY272001
TR-601	Transistor, 2SC1675-L (or 2SC1675-K2)		DDBY259001
<b>VARIABLE RESISTORS</b>			
VR-1	Semi-Fixed Resistor, RV-189 20K ohm B		RRVY189006
VR-2	Semi-Fixed Resistor, RV-189 100K ohm B		RRVY189008
VR-3	Semi-Fixed Resistor, RV-189 100K ohm B	P-6418	RRVY189008
VR-4	Semi-Fixed Resistor, RV-189 50K ohm B	P-6417	RRVY189007
VR-5	Semi-Fixed Resistor, RV-189 100K ohm B	P-6418	RRVY189008
VR-6	Semi-Fixed Resistor, RV-189 20K ohm B	P-6416	RRVY189006
VR-7	Semi-Fixed Resistor, RV-189 3K ohm B		RRVY189010
VR-8	Semi-Fixed Resistor, RV-189 10K ohm B	P-6415	RRVY189005
VR-9	Semi-Fixed Resistor, RV-189 5K ohm B	P-6414	RRVY189004
VR-12	Semi-Fixed Resistor, RV-189 100K ohm B	P-6418	RRVY189008
VR-15	Semi-Fixed Resistor, RV-189 300 ohm B	P-6420	RRVY189001
VR-16	Semi-Fixed Resistor, RV-189 300 ohm B	P-6420	RRVY189001
VR-401	Variable Resistor, RV-196 20K ohm B Clarifier		RRVY196001
VR-402	Variable Resistor, RV-282 100K ohm B RF Gain		RRVY282001
VR-404	Variable Resistor, RV-274 100K ohm B Squelch		RRVY274001
VR-405	Variable Resistor, RV-271 10K ohm A Volume		RRVY271001
VR-406	Variable Resistor, RV-274 1K ohm B Dimmer		RRVY274001
<b>CRYSTALS</b>			
X-1	X'tal, QX-017 7.8025 MHz	MX-2171	QQXY017001
X-2	X'tal, QX-054 7.7975 MHz	MX-2172	QQXY054001
X-3	X'tal, QX-081-003 11.2858 MHz	MX-2317	QQXY081003
X-4	X'tal, QX-081-001 11.2842 MHz	MX-2315	QQXY081001
X-5	X'tal, QX-080 10.2400 MHz	MX-2292	QQXY080001
X-6	X'tal, QX-081-002 11.2850 MHz	MX-2316	QQXY081002
<b>MISCELLANEOUS</b>			
SP-401	Speaker, SP-049	S-4686	ASPY 049001
MT-401	Meter, MT-141		ZMTY141001
	Relay, RL-027		ZRLY027001
MIC	Microphone, MK-020	M-2222	AMKY020001
J-401	Antenna Connector, JK-068, M Type (or JK-035)	J-0846	JJKY 068001

REF. NO.	DESCRIPTION	RS. PART NO.	MFRS PART NO.
J-402	Jack, JK-008, Microphone	J-0723	JJKY 008001
J-406	Socket, JK-052, DC Power	J-0819	JJKY 052001
J-403,404	Jack, JK-010, PA SP, EXT SP	J-0643	JJKY 010001
	Relay Socket, SK-018	J-6493	JSKY 018001
	Crystal Socket, SK-023		JSKY 023001
	Crystal Holder, YY-064		ZYYY064001
PL-401	Pilot Lamp, PL-065 (White)	L-0778	VPLY 065011
PL-402	Pilot Lamp, PL-066 (Red)	L-0779	VPLY 066003
TP-6	Check Terminal, TP-019 Test Point	J-6480	JTPY 019001
TP-7	Check Terminal, TP-019 Test Point	J-6480	JTPY 019001
TP-8	Check Terminal, TP-019 Test Point	J-6480	JTPY 019001
TP-9	Check Terminal, TP-019 Test Point	J-6480	JTPY 019001
TP-2	Check Terminal, TP-027 Test Point	J-4502	JTPY 027001
TP-4	Check Terminal, TP-027 Test Point	J-4502	JTPY 027001
	Fuse, FS-001 3A		ZFSY 001006
	Heat Sink, YD-035, TR-45		ZYDY035001
	Insulation Plate, YY-027, TR-43	HB-6156	ZYYY027001
	Insulation Plate, YD-003-003 Mica, TR-36	HB-6157	ZYDY003003
	Insulation bushing YY-036, TR-36	HB-6158	ZYYY036001
	Relay Holder, YY-046	HB-6173	ZYYY046001
	Wire Clamper, YY-047	HB-5880	ZYYY047001
	DC Cord, W-070101	W-1933	WZDZ070101
	Connector for FPC, JK-074 (or JK-079)	J-0847	JJKY 074001
	Connector for LED, JK-073-001	J-0848	JJKY 073001
	Connector for LED, JK-073-003	J-0849	JJKY 073003
	Connector for LED, JK-073-005	J-0850	JJKY 073005
	P.C. Board, (Main) PC-196BD		PPCY 196024
	Flexible P.C. Board, (CH Switch) PC-212AA	X-7421	PPCY 212011
	P.C. Board, (N.B.) PC-244AA	X-7422	PPCY 244011
	P.C. Board, (PA-EXT. SP) PC-243AA		PPCY 243011
T-1	Output Transformer TF-109	TD-0154	TTFY109001
FT-1	Crystal Filter, FL-001		FFLY001001
T402	Choke Coil, TF-122, DC Power		TTFY 122001

## 19. MECHANICAL PARTS LIST

REF. NO.	DESCRIPTION	RS. PART NO.	MFRS PART NO.
1	Chassis		MDBC203987
2	Cover, Top	Z-3493	MDBC204016
3	Cover, Bottom	Z-3494	MDBC204017
4	Bracket for Mounting	MB-0182	MDBP303992
5	Baffle Board for Speaker	Z-3495	MDBP303993
6	Chassis for Front Panel	Z-3496	MDBC304344
7	Angle for Main PCB	HB-6162	MDBP404010
8	Angle for CH. SW.	HB-6163	MDBP404024
9	Bracket for Lamps	HB-6164	MDBP404345
10	Ground Terminal for PA/EXT SPKR Jack		MDBP404006
11	Metal Plate for Shielding		MDBP404562
12	Clip (Conductor between Cover & Chassis)		MDBP403853
13	Channel Knob	K-2555	MDMP404011
14	Knobs (Volume, Clarifier, RF-GAIN, AM/USB/LSB)	K-2283	MDMP401728
15	Knob (Squelch)	K-2556	MDMP403072
16	Knob (Dimmer)	K-2557	MDMP404151
17	LED Holder (Front)		MDMP404790
18	LED Holder (Rear)	HB-6166	MDMP403857
19	LED Cap	HB-6167	MDMP403877
20	Front Panel	Z-3497	MDMP204343
21	Bracket Screw, Mounting		MDHP403997
22	Stud, Noise Blanker PCB		MDHP404350
23	Stud, Main PCB		MDHP404575
24	Control Trim Plate	Z-3498	MDNP404341
25	Name Plate	D-5256	MDAP404340
26	Cushion for Meter		MDNP404340
27	Washer (Fiber) 6 x 15 x 1		MDZP402177
28	Washer (Rubber) 6 x 15 x 2	HD-8221	MDZP400638
29	Washer (Rubber) 2 x 12 x 2		MDZP401703
30	Cover for Chassis	HB-6172	MDZP404005
31	Cushion for Meter	HB-4174	MDZP404015
32	Plate for Meter, Light Shielding		MDAP402767
33	Wool Washer		MDZP404304
34	Speaker Net		MDZP402081
35	Screw M3 x 6 (AF PWR AMP, IC4)	HD-2055	MZSS 123006
36	Screw M2.6 x 6 (Mic Jack)	HD-4014	MZSN 132606
37	Screw M3 x 8 (Front Panel)	HD-4021	MZSN 133008
38	Screw M2 x 5 (Switch NB)	HD-3209	MZSN 192005
39	Screw M2.6 x 5 (Switch MON)	HD-3018	MZSN 192605
40	Screw M2.6 x 10 (Dimmer Transistor)	HD-3056	MZSN 192610
41	Screw M3 x 6 (NB PCB)	HD-3026	MZSN 193006
42	Screw 5φ x 16 (Mounting Bracket)	HD-3052	MZSZ 235016
43	Screw M3 x 6 (Lug Terminal)		MZSZ 343006
44	Screw M3 x 8 (Main PCB)		MZSZ 343008

REF. NO.	DESCRIPTION	RS. PART NO.	MFRS PART NO.
45	Nut M2.6 (TR43 & TR36)		MZSN430026
46	Nut M3 (Speaker)	HD-7080	MZSZ 480030
47	Screw M3 x 5 (Cover, Top)		MZSB 193005
48	Washer 5φ (Mounting Bracket)		MZSZ 540050
49	Spring for Knob (Squelch)	RB-5868	MZTT200001
50	Spring for Knob (Dimmer)	RB-5855	MZTT200002
51	Spring for Knob (Channel)	RB-5756	MZTT200003
52	Masking Plate (Fiber)		MDZP404304
53	Meter	M-0262	ZMTY141001
54	Microphone Jack	M-2222	AMKY020001
55	Jack (DC Power)	J-0819	JJKY 052001
56	LED Socket	J-0848	JJKY 073001
57	LED Socket	J-0849	JJKY 073003
58	LED Socket	J-0850	JJKY 073005
59	Antenna Connector	J-0846	JJKY 068001
60	Main (P.C.B.)		PPCY 196024
61	Switch (Channel)	S-1276	SSRY 157001
62	Flexible P.C.B.	X-7421	PPCY 212011
63	Mode Switch	S-1277	SSRY 168001
64	Variable Resistor (SQ/DIM)		RRVY274001
65	Variable Resistor (RF GAIN)		RRVY282001
66	Variable Resistor (Clarifier)		RRVY196001
67	Variable Resistor (VOL/SW)		RRVY271001
68	Switch (MON/PA/CB)	S-2378	SSWY 076001
69	Switch (NB/OUT)	S-2379	SSWY 048001
70	P.C.B. for PA/EXT SPKR		PPCY 243011
71	P.C.B. for Noise Blanker	X-7422	PPCY 244011
72	Speaker	S-4686	ASPY 049001
73	Front Plate with RS mark		MDNP404342
	Shield Plate, PLL Shielding	RT-0939	MDBP403969
	Shield Plate, PLL Shielding	RT-0940	MDBP403970
	Shield Plate, Main PCB	RT-0941	MDBP402163
	Microphone Hanger	M-3105	MDBP402919
	Washer 3.5 (Mounting Bracket)		MZSN 193008
	Washer 3.5φ, Microphone Hanger	HD-8042	MZSZ 530035
	Lug Terminal 3φ, C418 & C419	HB-4089	MZTT150003
	Screw M3 x 8, Main PCB		MZSN343008
	Screw M4 x 8, Cover top & bottom		MZSN194008
	Screw 3.5φ x 8, Microphone Hanger	HD-3043	MZSZ 293508
	Screw M2.6 x 12, TR43 & TR44		MZSN192612
	Screw M2.6 x 6 (Mic. Jack)		MZSN132606
	Screw M2 x 5 (Slide Switch)		MZSN192005
	Screw M2.6 x 5 (Slide Switch)		MZSN192605

REF. NO.	DESCRIPTION	RS. PART NO.	MFRS PART NO.
	Screw M2.6 x 10 (DIMMER TR)		MZSN192610
	Screw M3 x 6 (NB PCB)		MZSN193006
	Screw M3 x 8 (T402, SP)		MZSN193008
	Screw 5 x 16 (Bracket)		MZSZ235016
	Screw M3 x 6 (Lug Terminal)		MZSZ343006
	Screw M3 x 5 (Lamp Holder)		MZSZ343005
	Nut M2.6 (DIMMER TR)		MZSN430026
	Nut M3 (Speaker)		MZSZ480030
	Screw M3 x 5		MZSB193005

**RADIO SHACK**  **A DIVISION OF TANDY CORPORATION**  
**U.S.A.: FORT WORTH, TEXAS 76102**  
**CANADA: BARRIE, ONTARIO L4M 4W5**

---

**TANDY CORPORATION**

**AUSTRALIA**

**280-316 VICTORIA ROAD  
RYDALMERE, N.S.W. 2116**

**BELGIUM**

**PARC INDUSTRIEL DE NANINNE  
5140 NANINNE**

**U. K.**

**BILSTON ROAD, WEDNESBURY  
WEST MIDLANDS WS10 7JN**