

ADDITIONAL

1965

VOLUME TV-24

Television

Servicing Information



Compiled by
M. N. BEITMAN

VOLUME TV-24

PRICE **\$3**

SUPREME PUBLICATIONS

ADDITIONAL

1965

Volume TV-24

Television

Servicing Information



Compiled by

M. N. BEITMAN

SUPREME PUBLICATIONS

SUPREME TV & Radio Manuals

ORDER FORM

SIMPLIFIES TV REPAIRS

These giant TV manuals have complete circuits, needed alignment facts, printed boards, servicing hints, production changes, voltage charts, waveforms, and double-page schematics. Here are your authentic service instructions to help you do expert work quicker; and priced at only \$3 per large annual manual.

COVER ALL POPULAR SETS

Here is your service data for faster, easier TV repairs. Lowest priced. Best by comparison. *Supreme TV* manuals have all needed service material on every popular TV set. Helpful, practical, factory-prepared data that will really make TV servicing easy for you. Benefit and save with these amazing values in service manuals. Only \$3 per large volume. Used by 184,000 wise servicemen for faster repairs. Join them; begin to make TV repairs easily and quickly.

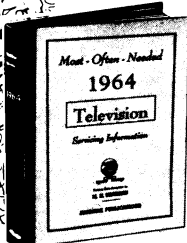

RADIO DIAGRAMS

Your best source for all needed RADIO diagrams and service data. Covers everything from most recent 1965 radios to pre-war old-timers; home radios, stereo, combinations, transistor portables, FM, auto sets. Only \$2.50 for many volumes. Every manual has large schematics, all needed alignment facts, printed boards, voltages, trimmers, dial stringing, and hints. Volumes are big, 8 1/2 x 11 inches, about 190 pages. See coupon at right for list of SUPREME popular radio service manuals



Simplified Radio Servicing by COMPARISON Method

Revolutionary different **COMPARISON** technique permits you to do expert work on all radio sets. Most repairs can be made without test equipment or with only a volt-ohmmeter. Many simple, point-to-point, cross-reference, circuit suggestions locate the faults instantly. Plan copyrighted. Covers every radio set — new and old models. This new servicing technique presented in handy manual form, size 8 1/2 x 11 inches, 48 pages. Over 1,000 practical service hints. 26 large, trouble-shooting blueprints. Charts for circuit analysis. 114 tests using a 5c resistor. Developed by M. N. Beitman. New edition. Price only..... **\$150**



TELEVISION SERVICING COURSE

Let this new course help you in TV servicing. Amazing bargain, complete, only \$3, full price for all lessons. Giant in size, mammoth in scope, topics just like a \$200.00 correspondence course. Lessons on picture faults, circuits, adjustments, short-cuts, UHF, alignment facts, hints, antenna problems, trouble-shooting, test equipment, picture analysis. Special, only **\$3**



RADIO MATHEMATICS

Explains arithmetic and simple algebra in connection with units, color code, meter scales, Ohm's law, alternating currents, ohmmeter testing, wattage rating, series and parallel connections, capacity, inductance, mixed circuits, vacuum tubes, curves, the decibel, etc., and has numerous examples. Only..... **25¢**



SUPREME PUBLICATIONS

1760 Balsam Rd., Highland Park, ILL.

★ Ship immediately Radio and TV manuals in quantities marked below.

Most-Ofen-Needed TELEVISION Manuals @ \$3.

| QUANTITY | VOLUME #TV | YEAR COVERED |
|----------|------------|--------------|
| | TV-23 | 1965 |
| | TV-22 | 1964 |
| | TV-21 | 1963 |
| | TV-20 | Late 1962 |
| | TV-19 | Early 1962 |
| | TV-18 | 1961 |
| | TV-17 | 1960 |
| | TV-16 | Late 1959 |
| | TV-15 | Early 1959 |
| | TV-14 | 1958 |
| | TV-13 | Late 1957 |
| | TV-12 | Early 1957 |
| | TV-11 | 1956 |
| | TV-10 | Late 1955 |
| | TV-9 | Early 1955 |
| | TV-8 | 1954 |
| | TV-7 | 1953 |
| | TV-6 | 1952 |
| | TV-5 | 1951 |

Most-Ofen-Needed RADIO Manuals @ \$2.50

| QUANTITY | VOLUME #R | YEAR COVERED |
|----------|-----------|--------------|
| | R-25 | 1965 |
| | 24 | 1964 |
| | 23 | 1963 |
| | 22 | 1962 |
| | 21 | 1961 |
| | 20 | 1960 |
| | 19 | 1959 |
| | 18 | 1958 |
| | 17 | 1957 |
| | 16 | 1956 |
| | 15 | 1955 |
| | 14 | 1954 |
| | 13 | 1953 |
| | 12 | 1952 |
| | 11 | 1951 |
| | 10 | 1950 |
| | 9 | 1949 |
| | 8 | 1948 |
| | 7 | 1947 |
| | 6 | 1946 |
| | 5 | 1942 |
| | 4 | 1941 |
| | 3 | 1940 |
| | 1 | 1926-1938 |

Master INDEX to above manuals, 25¢

TRAINING BOOKS

- Auto Radio 1964-1965 Diagrams, \$2.50
- Radio Servicing Course, new ed. 2.50
- Simplified Radio Servicing, 1.50
- Radio Mathematics (Self-help) .25
- Practical Radio & Electronics, 3.95
- Answer booklet to above course, .25
- Television Servicing Course, 3.00

- I am enclosing \$..... Send postpaid.
- Send C.O.D. I am enclosing \$... deposit.

Name: _____

Address: _____

Supreme Publications
Sold by All Leading Parts Jobbers

ADMIRAL

GENERAL

The basic G6 chassis covered by this manual is designed with most all components mounted on one precision-wired etched circuit board. This board contains 90% of all chassis parts with the part symbols and test point locations all identified on top of the board.

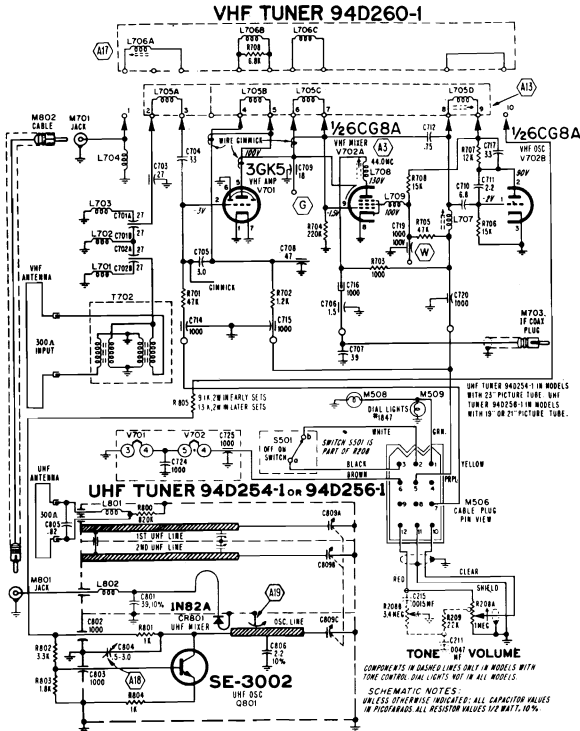

CLUSTER ASSY. FOR G612-1, G620-1, -2, OR -3

| MODEL CHART | | | | |
|-------------|------------|-------------|------|------------------------|
| MODEL | COLOR | NAME | SIZE | CHASSIS |
| TG9728 | Gray | Cavalier | 19" | G620-1 |
| PG9734 | Beige | Kingsley | 19" | G620-3 |
| PG9737 | Walnut | | | |
| PG9739 | White | | | |
| PG9744 | Brown | Coronet | 19" | G620-2 |
| PG9749 | White | | | |
| PG2134 | Beige | Avalon | 21" | G620-2 |
| PG2137 | Walnut | | | |
| PG2139 | White | | | |
| PG2144 | Beige | Newport | 21" | G620-2 |
| PG2149 | White | | | |
| TG3010 | Charcoal | Westerly | 23" | G612-1 or G613-1 |
| TG3011 | Brown | | | |
| TG3013 | Beige | | | |
| TG3021 | Walnut | Creston | 23" | G610-2 or G617-2 |
| TG3022 | Mahogany | | | |
| TG3031 | Walnut | Hedgeworth | 23" | G612-1 or G613-1 |
| LG3011 | Walnut | | | |
| LG3012 | Mahogany | | | |
| LG3015 | Maple | Westmount | 23" | G612-1 or G613-1 |
| CG3011 | Walnut | | | |
| CG3012 | Mahogany | Westchester | 23" | G612-1 or G613-1 |
| LG3021 | Walnut | | | |
| LG3022 | Mahogany | | | |
| LG3025 | Maple | Lowell | 23" | G610-2 or G617-2 |
| LG3041 | Walnut | | | |
| LG3045 | Maple | Spencer | 23" | G610-2 or G617-2 |
| LG3049 | Cherrywood | | | |
| SMG300T | Walnut | Kenilworth | 23" | G610-3 |
| SMG3002 | Mahogany | | | |

SMG3001 & 2 also use the 22C5 radio

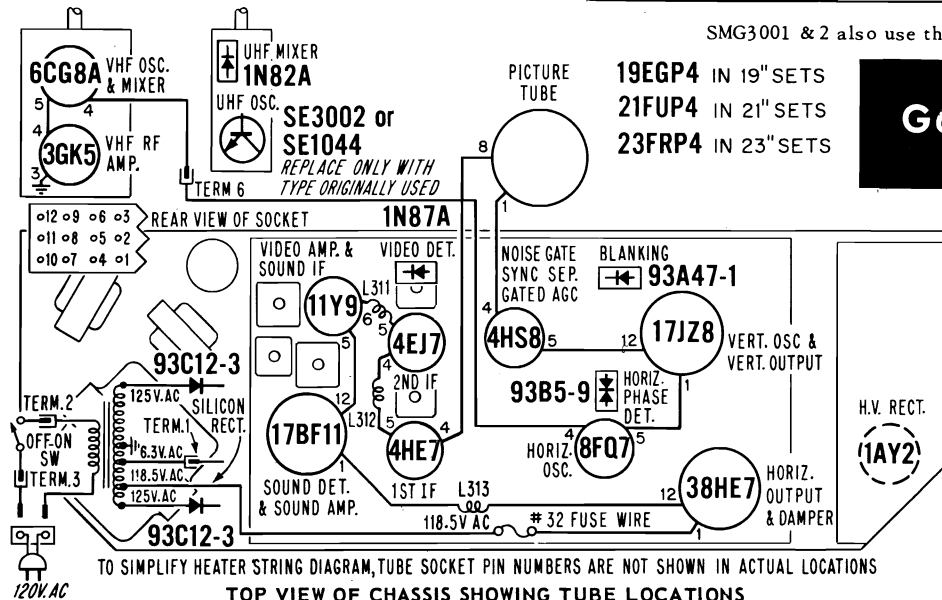

TO SIMPLIFY HEATER STRING DIAGRAM, TUBE SOCKET PIN NUMBERS ARE NOT SHOWN IN ACTUAL LOCATIONS
TOP VIEW OF CHASSIS SHOWING TUBE LOCATIONS

G6 CHASSIS

19EGP4 IN 19" SETS
21FUP4 IN 21" SETS
23FRP4 IN 23" SETS

ADMIRAL G6 Chassis Group, Schematic Diagram

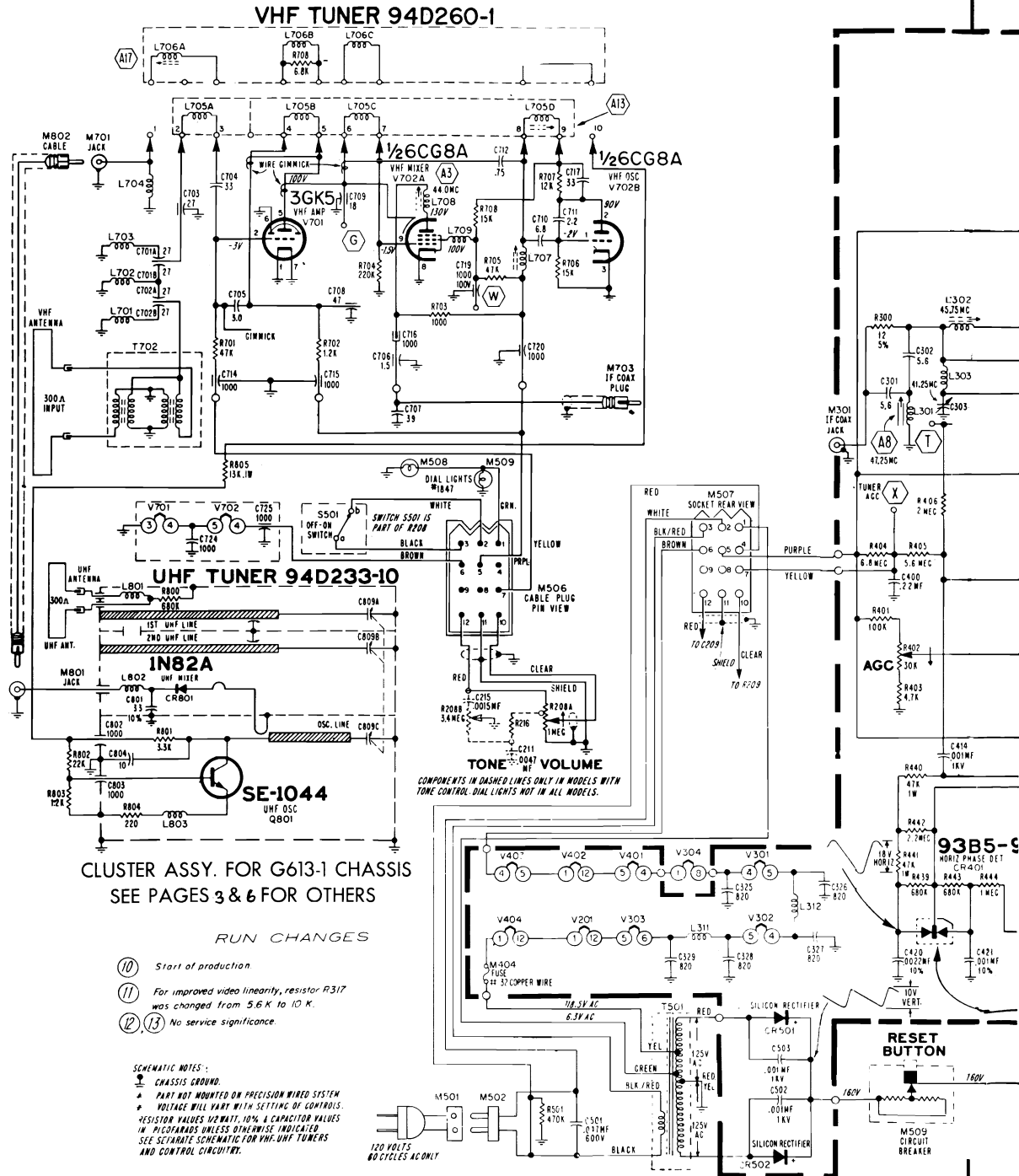

G6 CHASSIS SCHEMATIC DIAGRAM WITH CLUSTER ASSY. G613-1

PICTURE CENTERING AND TILT RASTERING

For picture centering move the metal tabs on the back of the deflection yoke closer together or farther apart while monitoring picture. Adjust tabs so that picture is centered and does not leave shadowed areas. If the raster does not fill the screen it may be necessary to adjust the height, linearity or width adjustment.

If the raster is tilted, loosen the yoke retaining clamp and rotate the yoke assembly to produce horizontal trace lines with respect to the top or bottom of the set.

VERTICAL HEIGHT AND LINEARITY ADJUSTMENT

If the raster does not fill the screen at the top or bottom, or if the top or the bottom of the picture is squeezed or stretched, this adjustment will be required after centering picture:

Alternately adjust the Vertical Height and Vertical Linearity controls on the back of the chassis so that the raster is equally scanned with approximately 3/8" overscan on both the top and bottom. Incorrect setting of these controls is likely to cause vertical foldover or vertical instability.

VOLUME TV-24, ADDITIONAL 1965 TELEVISION SERVICING INFORMATION

ADMIRAL G6 Chassis Group, Adjustment Information, Continued

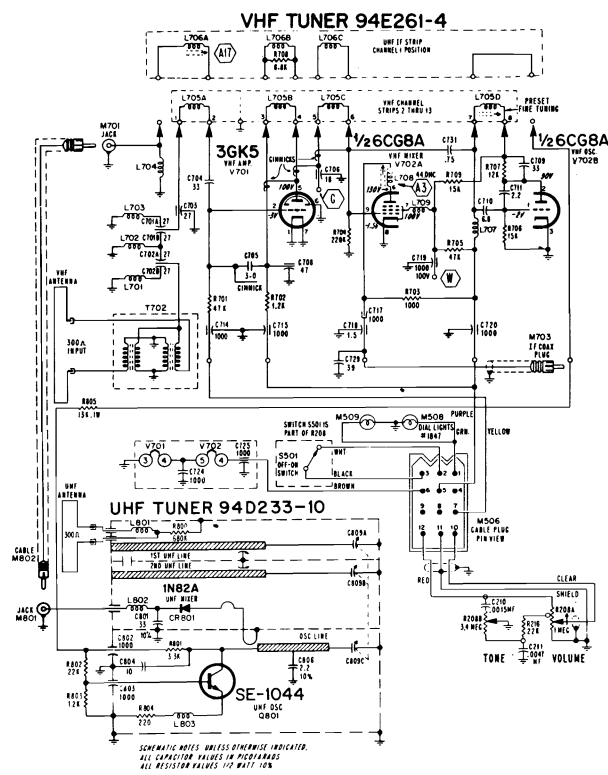

CLUSTER ASSY. FOR G617-2, -3

VHF PRE-SET FINE TUNING OR OSCILLATOR ADJUSTMENT

Some models using the G6 are equipped with a VHF tuner having pre-set fine tuning for each VHF channel. Adjust the fine tuning knob for best picture consistent with good sound after the set has warmed up for five minutes. Repeat this procedure for each used VHF channel. There is no other oscillator slug on pre-set fine tuning models.

Other models use a tuner having an oscillator slug adjustment for each channel. Adjust as follows:

1. Turn set on and allow 15 minutes for warm up.
2. Set channel to highest VHF channel to be used. Set fine tuning control at center of tuning range by rotating it 1/3 turn counterclockwise from full clockwise position. Set other controls for normal picture and sound.
3. Remove channel selector and fine tuning knobs. The oscillator slug can be seen through a hole provided above and to the left of the shaft.
4. Using non-metallic alignment tool carefully adjust the channel slug for best picture consistent with good sound. Repeat procedure for each used VHF channel in descending order.

AGC CONTROL ADJUSTMENT

The AGC control is an AGC threshold control which is used solely to adjust the receiver for optimum operation under all signal conditions.

Note: This control is set at the factory and will not normally require field readjustment.

Improper AGC control adjustment can result in picture bending, tearing (overloading) or buzz in the sound. However, these same conditions can also be caused by other troubles in the set. Make adjustment as follows:

1. Turn set on and allow 15 minutes to warm up.
2. Turn Channel Selector to strongest station in the area.

3. Turn Contrast and Brightness controls fully to the right.
4. Very slowly turn AGC control to the left, just to the point where picture is weak (loses contrast).
5. Adjust Horizontal Lock (at rear of set) and Vertical Hold control (at side of set) for steady picture, without bending of vertical lines at top of picture.
6. Very slowly turn AGC control to the right, until picture just begins to bend, tear, shift, or buzz is heard in sound. Then very slowly turn the AGC control to the left, to the point at which picture bending, tearing, shifting and buzz is removed.
7. Make final adjustment by turning AGC control an additional 10 degrees to the left.
8. Recheck at maximum contrast on all channels. Picture should not overload and should reappear immediately after changing channels.

IMPORTANT: AGC adjustment should always be made on the strongest TV station received. If adjustment is made only on a weak station, AGC overload may occur when a strong TV station is tuned in.

HORIZONTAL LOCK ADJUSTMENT

Make adjustment if picture "slips sideways" or "tears" when switching channels. Adjustment is made by rotating flexible shaft extending from rear of set. Adjust as follows:

1. Allow a few minutes for set to warm up. Tune in weakest station, set Brightness and Contrast controls for normal Picture. Important: Before proceeding, be sure that AGC control has been adjusted according to instructions in this manual.
2. Reduce Contrast to minimum. Very slowly turn Horizontal Lock adjustment to the right or left until picture is in sync. Interrupt the television signal by switching Channel Selector off and on channel. Picture should remain in sync. If picture bends or loses sync, adjust Horizontal Lock so that picture remains in sync and bending of vertical lines does not appear at top of picture. Check adjustment on all channels.

IMPORTANT: If adjustment cannot be made using the Horizontal Lock control, it will be necessary to make Horizontal Range adjustment as instructed below.

HORIZONTAL RANGE ADJUSTMENT

The Horizontal Range control is set at the factory and seldom requires readjustment. Adjustment need only be made if 8FQ7 tube (V403) has been replaced and the picture cannot be locked-in with the Horizontal Lock adjustment or if the Horizontal Lock adjustment has insufficient range (adjustment only possible at extreme end rotation). Note: Horizontal Range adjustment is accessible after removing cabinet back.

Caution: Before proceeding with adjustment, be sure that the picture will sync vertically, as lack of both vertical and horizontal sync indicates sync circuit trouble. Lack of only horizontal sync generally indicates trouble in the horizontal sync (phase detector) circuit. Adjust as follows:

1. Remove cabinet back. Connect interlock cord.
2. Allow a few minutes for set to warm up. Tune in weakest station, set Brightness and Contrast controls for a normal picture. Important: Before proceeding, be sure that the AGC control has been adjusted according to instructions in this manual.
3. Using a piece of hook-up wire, short test point "R" (pin 2 of V403, 8FQ7 tube), to chassis ground. See figure B for test point locations.
4. Connect a .22 mf 400 volt capacitor from test point "S" (junction of horizontal lock coil L401 and resistor R446, 15,000 ohms) to chassis ground. Caution: To avoid B+ shock, turn receiver off when making this connection.
5. With picture in vertical sync, set Horizontal Range control at point where picture is in horizontal sync and almost remains stationary with tendency to shift to left or right.
6. Remove the .22 mf capacitor from the horizontal lock coil. Set horizontal lock coil at point where picture is in horizontal sync and almost remains stationary with tendency to shift to left or right.
7. Remove wire short from test point "R". Set Channel Selector to weakest station. Switch Channel Selector on and off channel, picture should remain in horizontal sync. If necessary, adjust horizontal lock coil slightly to bring picture in sync.

VOLUME TV-24, ADDITIONAL 1965 TELEVISION SERVICING INFORMATION

ADMIRAL G6 Chassis Group, Alignment Information, Continued

TELEVISION ALIGNMENT

ALIGNMENT TEST EQUIPMENT

The following test equipment is required for complete IF alignment:

1. Crystal calibrated signal generator to cover the IF frequency range (41.25MC-47.25MC).
2. Sweep generator covering the 40-50MC range. It should have variable sweep up to 7MC.
3. VTVM and 2 short clip leads.
4. 7 volt bias supply.
5. Wideband oscilloscope.
6. Alignment tools 98A30-12 and 98A30-14. Matching networks are required for equipment termination.

ALIGNMENT PROCEDURES

- A. Connect a negative 7 volt bias supply to test point "T" (IF AGC) and "X" (RF AGC), positive to chassis. See figure B.
 - B. Using needle nose alligator clip or hookup wire, connect signal generator high side to test point "G", low side directly to tuner. See figure D.
 - C. Connect VTVM high side to test point "V" through a decoupling filter. See figure G. Connect low side to chassis.
 - D. Set Channel Selector to Channel 12. Short out antenna terminals at the tuner.
 - E. Allow about 15 minutes for receiver and test equipment to warm up. Use non-metallic alignment tools, part no. 98A30-12 and 98A30-14. Tube shields and all chassis shields must be in place.
- *1. Set generator at 47.25MC and adjust A8 for *minimum*.
 - *2. Set generator at 41.25MC and adjust A7 for *minimum*. If necessary, reduce bias and/or increase generator output for trap adjustments.
 3. Connect a jumper wire across L302.
 4. Set generator at 44MC and adjust L708 (on VHF tuner) for maximum. See Fig. D.
 5. Remove jumper wire connected in Step 3.
 6. Set generator at 45.75MC and adjust L302 for maximum.
 7. Repeat Steps 1 & 2.
 8. Set generator at 44MC and adjust A1 (bottom core T302) for maximum.
 9. Leave generator at 44MC and adjust A3 for maximum.

10. Leave generator at 44MC and adjust A2 for maximum.
11. Set generator at 45.75MC and adjust A5 for maximum.
12. To insure correct carrier position and bandwidth, proceed with "IF Response Curve Check."

IF RESPONSE CURVE CHECK

1. Allow about 15 minutes for receiver and test equipment to warm up.
2. Set VHF tuner to Channel 12. Connect negative of 7 volt bias supply to test points "T" and "X"; positive to chassis.
3. Connect generator to VHF tuner. Test point "G" through the generator matching network of figure H. Ground low side nearby.
4. Connect oscilloscope high side to test point "V" through a decoupling filter (see figure G), low side to chassis.
5. The IF curve now obtained should be checked against the ideal response curve (see figure C). Maintain sweep output at 3VPP as alignment progresses. Keep markers low. A reduction in sweep output should reduce curve amplitude without appreciably altering the shape of the response curve.
6. If the curve is not within tolerance or markers not in proper location, A3 should be adjusted for 45.75MC video marker and A1 for rounded curve nose.

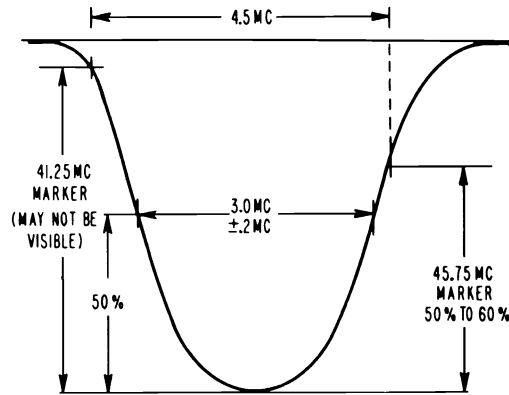
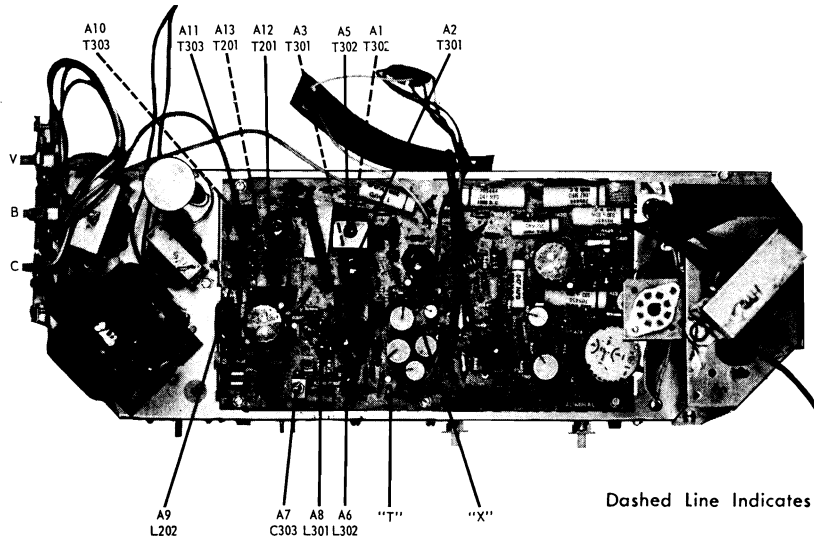

Figure C. Ideal IF Response Curve.



Dashed Line Indicates Bottom Adjustments.

Figure B. View of Precision Wired System Showing Test Point and Alignment Locations.

ADMIRAL G6 Chassis Group, Alignment Information, Continued

VHF AMPLIFIER AND MIXER ALIGNMENT

Tuners 94E260 and 94E261 are turret types that feature high stability and trouble-free operation. The 94E261 has pre-set fine tuning and 94E260 is the conventional. The inductors of these tuners consist of individual channel strips and in general, RF and mixer alignment is permanent. Individual channel oscillator slugs are provided for each channel of 94E260, should oscillator adjustment be required after replacement of VHF oscillator tube. See figure D for tuner adjustment locations. If it is definitely determined that complete tuner alignment is required, return tuner to Admiral Distributor for repair or replacement.

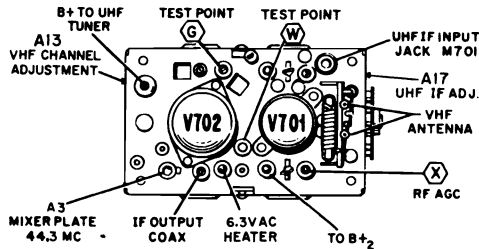

Fig. D TOP VIEW OF VHF TUNER

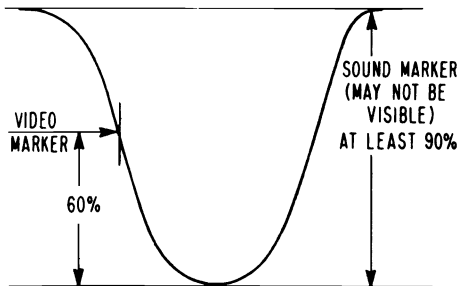

Fig. E OVER-ALL IF CURVE & IF RESPONSE CURVE

OVERALL RESPONSE CURVE CHECK

This procedure is for checking alignment for a quick service check of the RF-IF sections of the receiver.

- Follow "Alignment Test Equipment" and "General Alignment Instructions" excepting:
 - Apply -2 volts bias to TP-X.
 - Apply -7 volts bias to TP-T.
- Attach the sweep generator at the VHF tuner antenna terminals, high side through 1200 ohm resistor, low side through 1200 ohm resistor. Place a 330 ohm resistor across the antenna terminals and a 47 ohm resistor across the generator output.
- Set the channel selector to Channel 13.
- Accurately set marker at 211.25MC. (video carrier frequency of Channel 13).
- Monitor the IF output through the decoupling filter connected to TP-L. Maintain 3VPP scope amplitude as procedure continues.
- Using the fine tuning control, set the video carrier marker on the correct side at 60% (45.75MC).
- Observe the response as shown in figure E..
- Repeat 4, 5, 6 and 7 for other VHF Channels, using correct Channel marker.
- In most instances severe tilt on one channel only will indicate that that particular tuner strip is out of adjustment, a defective balun, input trap or bypass capacitor. Severe tilt on all channels can be tuner trouble, but usually the problem will be found with the IF strip. Never neglect the tubes, including the RF and VHF mixer. Be particularly aware of lead dress and sweep generator linearity. If the tilt is on all channels and is not severe it can usually be compensated for by adjusting T302 BOTTOM SLUG.

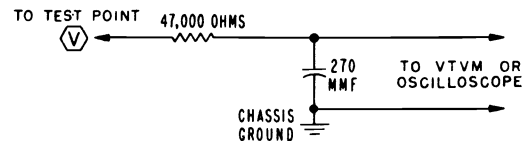

Fig. G DECOUPLING FILTER

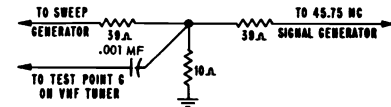

Fig. H MATCHING NETWORK

ALIGNMENT OF UHF IF INPUT USING A TRANSMITTED SIGNAL

Alignment of UHF IF input coil (part of VHF tuner), should be made if UHF reception is poor and after usual causes of poor UHF reception have been checked.

To align UHF IF input coil, tune in UHF channel with normal picture and sound. Using non-metallic alignment tool very carefully adjust slug A17 for best picture, consistent with good sound. For VHF tuner adjustment locations, see figure D.

4.5MC SOUND IF ALIGNMENT

- Tune in normal picture on strongest TV station. Allow about 15 minutes for set to warm up. AGC control must be in proper adjustment. Adjust other controls for normal operation. Refer to chassis views and schematic for alignment locations.
- Using a non-metallic alignment tool (part no. 98B30-12), and starting with L202 turned slug to the top of its form, screw it several turns into the form until the loudest and clearest position is found. There may be two points (approximately 1/2 turn apart) at which the sound is loudest. The slug should be centered over the innermost of the two points.
- Reduce the signal at the antenna terminals until there is considerable hiss in the sound. For best results, use a step attenuator connected between antenna and antenna terminals. The signal can also be reduced by disconnecting the antenna and fastening it near the antenna terminals. It is important to keep the signal below limiting (hissing) as the alignment progresses.
- Adjust T201 top slug for maximum output and minimum hiss. If this slug requires considerable adjustment, touch-up L202.†
- Adjust T201 bottom slug for maximum output and minimum hiss.
- Adjust T303 bottom slug for maximum output and minimum hiss. NOTE: The top slug is a 4.5mc trap. Do not adjust it as part of sound alignment.
- If above alignment is correctly made, no further adjustment is required. However, if sound remains distorted at normal volume (when receiver is properly tuned), repeat entire procedure.

†Do not readjust L202 further unless sound is distorted. Re-adjustment of L202 beyond this point will require all sound adjustments to be repeated.

ALIGNMENT OF 4.5 MC TRAP

Alignment of 4.5 MC (beat interference) trap "A11" requires use of a hexagonal non-metallic alignment tool (part number 98A30-12).

To align 4.5 MC trap "A11", tune in television station with beat interference pattern in picture. While closely observing picture, adjust slug "A11" for minimum interference pattern.

Note that adjustment "A11" is top slug (slug farthest from bottom of coil). Use caution so as not to disturb bottom slug (slug nearest bottom of coil) as sound IF alignment will be affected.

UHF TUNER ALIGNMENT AND REPAIR

Failure of the UHF tuner is often the 1N82A mixer diode, since it can be damaged by static discharges. Replace the diode by first removing the tuner shield. Then use a pair of tweezers to grasp the diode.

Admiral

**C21B12-1,13-1,
C21C12-1,13-1,15-1**

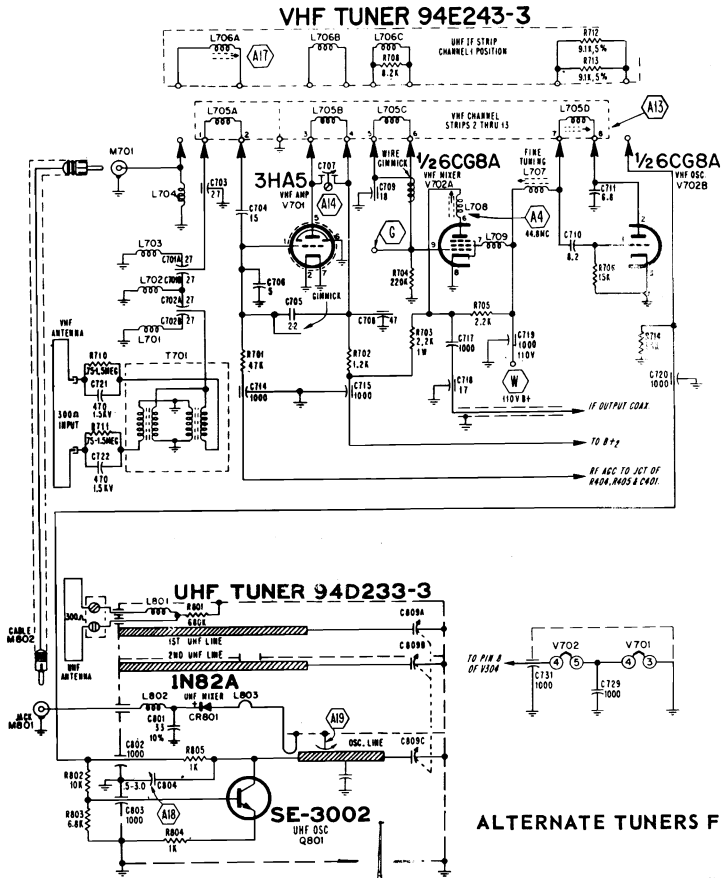

| MODEL IDENTIFICATION CHART | | | |
|--|--|---|------|
| MODEL | FINISH | CHASSIS | SIZE |
| PD1124 | Beige | C21B12-1HR OR -1G OR -1S OR -1N OR -1R OR -1T OR 1V | 11" |
| PD1130 PD1131 PD1132 PD1139 | Black Brown Red White | C21B12-HR OR -1G OR -1S OR -1N OR -1R OR -1T OR 1V | 11" |
| PD1303 PD1304 PD1310 PD1311 PD1312 PD1319 | Sungold Beige Black Brown Red White | C21C12-1 OR C21C13-1 OR C21C15-1 | 13" |
| PG1129 | White | C21B12-1S | 11" |
| PG1308 PG1310 PG1311 PG1319 | Gray Black Sandalwood White | C21C12-1C or C21C15-1 or C21C15-1AS or C21C15-1AG | 13" |
| PG1320 PG1322 PG1325 PG1329 | Black Red Green White | C21C15-1 or C21C15-1AS or C21C15-1AG | 13" |

ALTERNATE TUNERS FOR C21B12-1HR CHASSIS

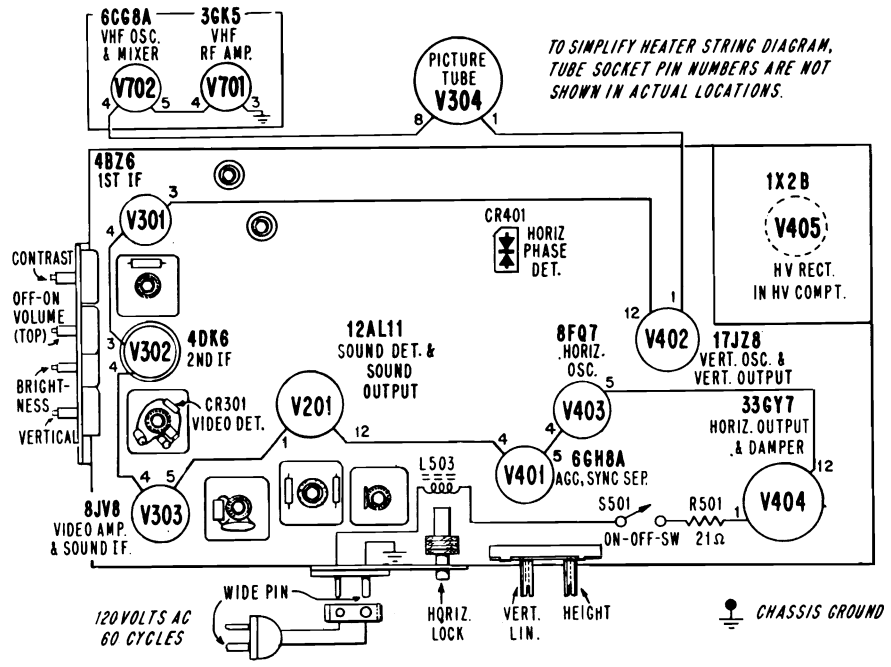
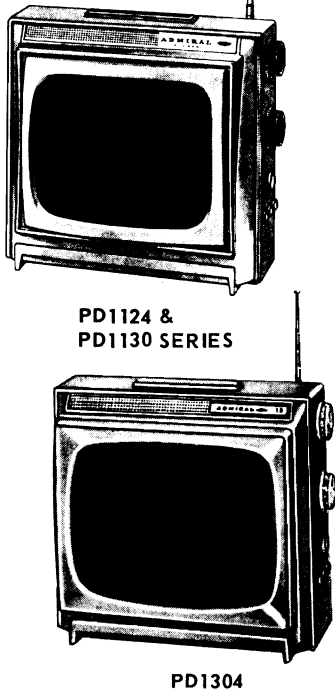

Fig. 1 DRAWING OF TOP OF CHASSIS SHOWING CONTROLS AND HEATER HOOK-UP

ADMIRAL C21 Chassis Group, Alignment Information, Continued

IF AMPLIFIER ALIGNMENT

Connect isolation transformer between AC line and receiver. Connect negative of 4 volt bias supply to test point "T" (IF AGC), positive to chassis. See Figure 6.

Using needle nose alligator clip or looped end of hookup wire, connect signal generator high side to test point "G", low side directly to tuner, see Figure 2.

Connect VTVM high side to test point "V" through a decoupling filter, see Figure 4. Connect low side to chassis.

Set Channel Selector to channel 12. (Or other high end channel which does not affect indication). Connect jumper wire across antenna terminals.

Allow about 15 minutes for receiver and test equipment to warm up. Use a non-metallic alignment tool.

IMPORTANT: Before proceeding check signal generator against frequency standard for calibration.

SUGGESTION: Alignment is best accomplished by first removing chassis and reconnecting facing backwards.

1. Set generator at 42.7MC and adjust A1 for maximum.
2. Set generator at 44.2MC and adjust A2 for maximum.
3. Set generator at 44.3MC and adjust A3 for maximum.
4. Connect wire jumper across IF input coil L302.
5. Set generator at 44.8MC and adjust A4 for maximum.
6. Remove wire jumper of step 4.
7. Set generator at 42.7MC and adjust A5 for maximum.
8. Reduce bias to -1½ volts.
9. Set generator at 47.25MC and adjust A6 for minimum.
10. Restore -4 volt bias.
11. Disconnect generator and connect sweep generator. Loosely couple marker to sweep connection.
12. Disconnect VTVM, and connect oscilloscope to network.
13. Set sweep frequency at 43MC, sweep width approximately 7MC. Keep marker and sweep outputs at low level to prevent over-loading. A reduction in sweep output should reduce curve amplitude without altering the shape of the response curve.
14. If 45.75MC marker is not within tolerance or markers not in proper location on curve, adjust A4 to position 45.75MC marker. Adjust A1 to correct shape of curve. Avoid reducing amplitude of curve as much as possible.

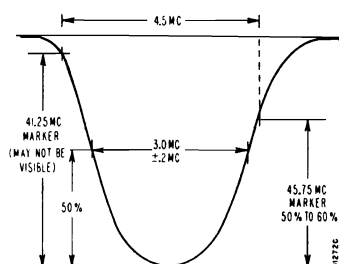

Fig. 5 IF CURVE

IF RESPONSE CURVE CHECK

1. Set VHF tuner on channel 12. Connect negative of 6 volts bias supply to test point "T" (IF AGC), positive to chassis. See figure 6.
2. Using needle nose alligator clip or looped end of hook-up wire, connect sweep generator high side to test point "G", low side directly to tuner, see figure 2. Set sweep frequency to 43 MC, sweep width approximately 7 MC. If external marker generator is used, loosely couple high side to sweep generator lead, low side directly to tuner. Marker frequencies indicated on IF Response Curve.
3. Connect oscilloscope high side to test point "V" through a decoupling filter (figure 4.), low side to chassis.
4. Check curve obtained against ideal response curve, figure 5.
5. Keep marker and sweep outputs at very minimum to prevent over-loading. A reduction in sweep output should reduce curve amplitude without altering the shape of the response curve.

If curve is not within tolerance or markers not in proper location on curve, adjust A4 to position 45.75 MC Video Marker. Adjust A1 to correct shape of curve.

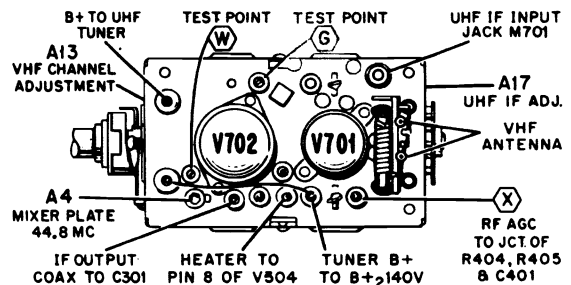

Fig. 2 TOP DRAWING OF VHF TUNER

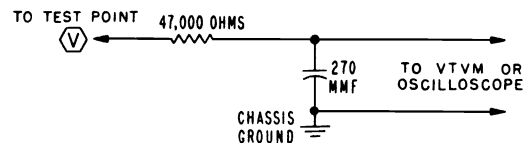

Fig. 4 DECOUPLING FILTER

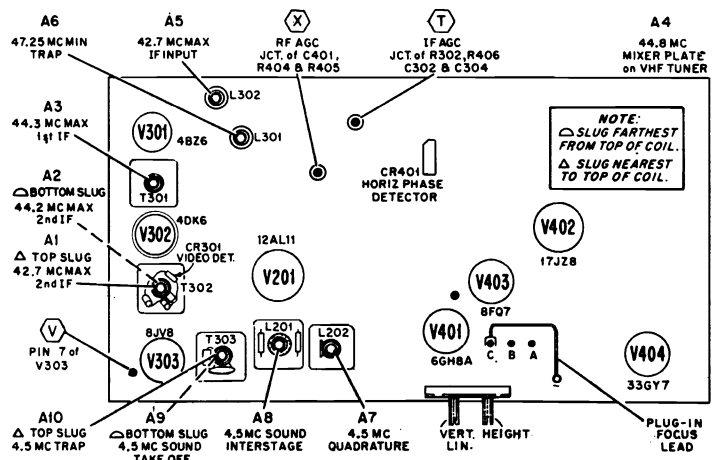

Fig. 6 TOP DRAWING OF CHASSIS SHOWING TUBE AND ALIGNMENT LOCATIONS

ADMIRAL C21 Chassis Group, Alignment Information, Continued

VHF AMPLIFIER AND MIXER ALIGNMENT

VHF tuners used in these receivers feature high stability and trouble-free operation. In general, RF and mixer alignment is permanent. However, individual channel oscillator screws or slugs are provided, should oscillator adjustment be required after replacement of VHF oscillator tube. For tuner adjustment locations, see figures 2 and 3. If it is definitely determined that complete tuner alignment is required, return tuner to your Admiral distributor for repair or replacement. Note: VHF Channel Adjustment can be made from side of set after removing VHF channel and fine tuning knobs.

OVER-ALL VHF AND IF RESPONSE CURVE CHECK

Set AGC control fully to the left. Channel Selector on channel 12. Connect negative of 3V bias supply to test points "T" (IF AGC) and "X" (RF AGC), positive to chassis. See figure 6.

Connect isolation transformer between AC line and receiver. Allow about 15 minutes for receiver and test equipment to warm up.

Connect sweep generator to antenna terminals. Set sweep to channel 12 with sweep output as low as possible. If an external marker generator is used, loosely couple high side to sweep generator lead.

Connect oscilloscope high side to test point "V" through decoupling filter, low side to chassis.

Compare response curve obtained against ideal curve shown in figure 8. If the curve is not within tolerance, adjust A4 to position video marker; adjust A1 to correct shape of curve. It should never be necessary to turn slugs more than one turn in either direction. If curve is satisfactory on channel checked, all other channels should be satisfactory. IMPORTANT: When sweep output is reduced, response curve amplitude on scope should also decrease, but curve shape should remain the same. If curve shape changes, reduce sweep output and/or scope gain until shape does not change.

ALIGNMENT OF UHF IF INPUT USING A TRANSMITTED SIGNAL

Alignment of UHF IF input coil (part of VHF tuner), should be made if UHF reception is poor and after usual causes of poor UHF reception have been checked.

To align UHF IF input coil, tune in UHF channel with normal picture and sound. Using non-metallic alignment tool very carefully adjust slug A17 for best picture, consistent with good sound. For VHF tuner adjustment locations, see figure 2.

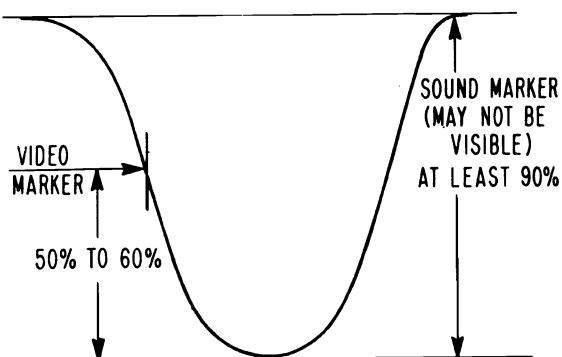

Fig. 8 OVER-ALL IF CURVE

4.5 MC SOUND IF ALIGNMENT

1. Tune in normal picture on strongest TV station. Allow about 15 minutes for set to warm up. See figure 6 for adjustment locations.
2. Using non-metallic alignment tool, slowly turn slug "A7" several turns to left until a buzz is heard in sound. Then slowly turn slug "A7" to the right for loudest and clearest sound. NOTE: There may be two points (approx. 1/2 turn apart) at which sound is loudest. The slug should be set at center of second point of loudest sound noted as slug is turned in (toward bottom of coil).
3. Reduce signal to antenna terminals until there is considerable hiss in sound. For best results, use a step attenuator, connected between antenna and antenna terminals. Signal can also be reduced by disconnecting antenna and placing it close to antenna terminals or leads.
4. Carefully adjust slug "A8" for loudest and clearest sound with minimum hiss. If hiss disappears during alignment, reduce signal to maintain hiss level. Re-adjust slug "A8". NOTE: Slug "A8" should be at end nearest bottom of coil.
5. Carefully adjust slug "A9" for loudest and clearest sound with minimum hiss. If hiss disappears during alignment, reduce signal to maintain hiss level. Re-adjust slug "A9". Caution: Slug "A9" is located nearest bottom of coil. Use care so as not to disturb slug nearest top of coil.
6. If above alignment is correctly made, no further adjustment is required. However, if sound remains distorted at normal volume level (when receiver is tuned for best sound), repeat entire procedure.

*CAUTION: Do not re-adjust slug "A7" unless sound is distorted. If "A7" is re-adjusted, all steps in alignment procedure should be repeated exactly as instructed.

ALIGNMENT OF 4.5 MC TRAP

Alignment of 4.5 MC (beat interference) trap "A10" requires use of a hexagonal non-metallic alignment tool.

To align 4.5 MC trap "A10", tune in television station with beat interference pattern in picture. While closely observing picture, adjust slug "A10" for minimum interference pattern.

Note that adjustment "A10" is top slug (slug farthest from bottom of coil). Use caution so as not to disturb bottom slug (slug nearest bottom of coil) as sound IF alignment will be affected.

VHF CHANNEL SLUGS ACCESSIBLE THROUGH HOLE IN VHF TUNER

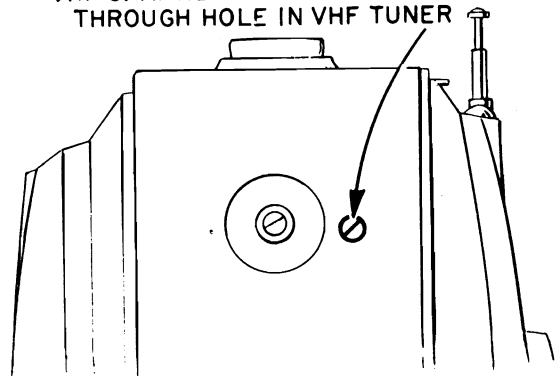
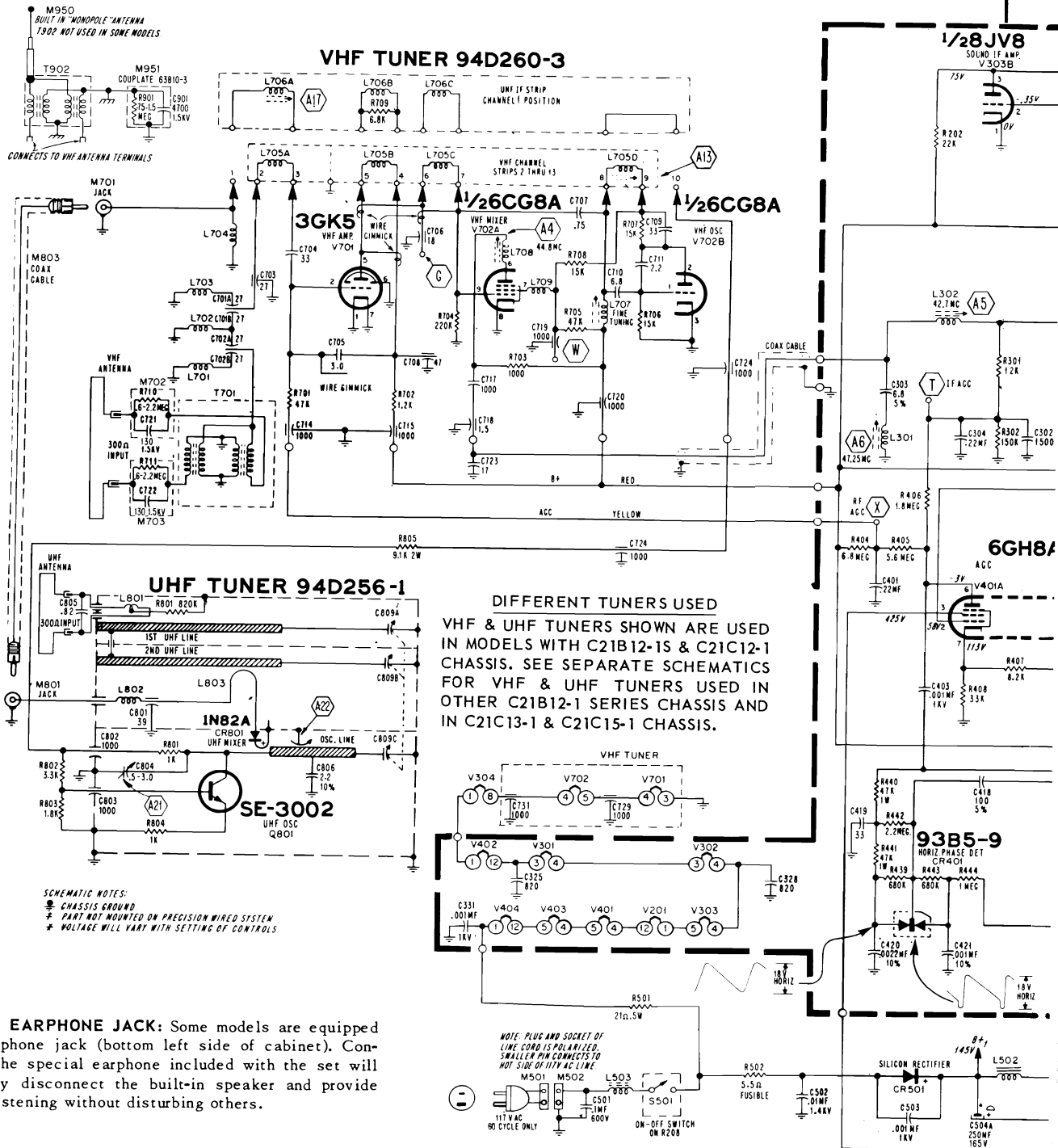

Fig. 3 DRAWING SHOWING OSCILLATOR SLUG

VOLUME TV-24, ADDITIONAL 1965 TELEVISION SERVICING INFORMATION

ADMIRAL C2i Chassis Group, Schematic Diagram



USING THE EARPHONE JACK: Some models are equipped with an earphone jack (bottom left side of cabinet). Connection of the special earphone included with the set will automatically disconnect the built-in speaker and provide "private" listening without disturbing others.

PICTURE TUBE REPLACEMENT NOTE

These receivers use a picture tube with steel bonded frame mounted around face plate of picture tube. To prevent possibility of static discharge, capristor M302 should connect from chassis ground to solder lug on steel bonded frame of picture tube. Shield braid (grounding lead) should connect from chassis to VHF tuner mounting bracket.

Do not connect steel bonded frame (around faceplate of picture tube) directly to picture tube dag or chassis ground.

CLEANING CABINET

Never operate set when washing cabinet and picture tube face. Wash cabinet and picture tube face with cloth dampened and thoroughly wrung out in mild soapy water. Never use scouring abrasives which may scratch cabinet or picture tube face. Rinse cloth in clear water and wipe thoroughly.

WARNING: Do not attempt to clean plastic cabinet and picture tube face with hydrocarbon solvents such as turpentine, benzene, naphtha or mineral spirits.

VOLUME TV-24, ADDITIONAL 1965 TELEVISION SERVICING INFORMATION

ADMIRAL C21 Chassis Group, Schematic Diagram, Continued

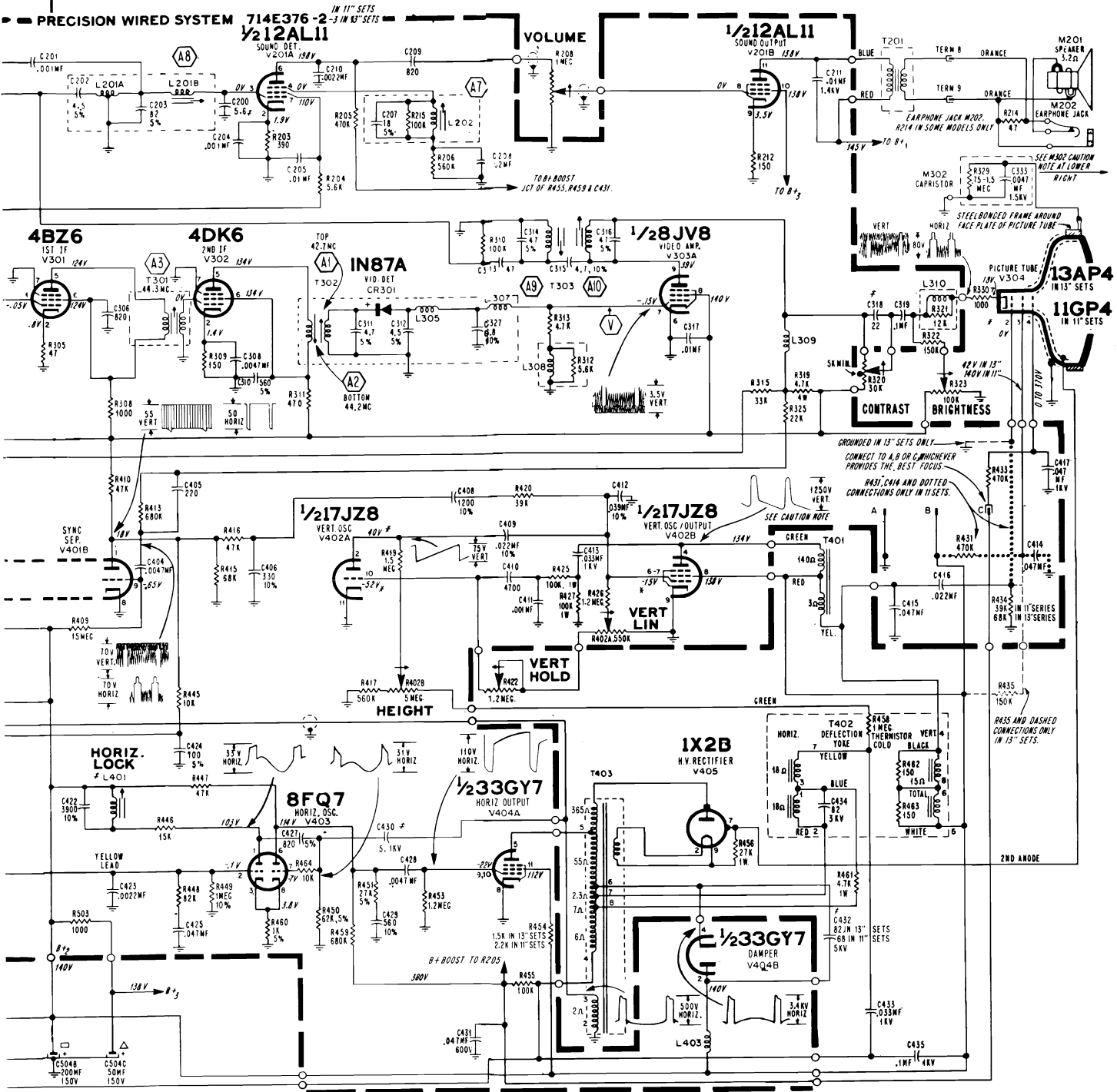

IMPROVING FOCUS

The picture tube of these receivers utilizes electrostatic focus in connection with a three position focus adjustment.

For obtaining best overall sharpness of pictures, focus adjustment should be checked at installation and when servicing. Once focus adjustment is properly made, no further need for readjustment is required.

There are three focus connection pins located near the

Height control on the etched circuit board. See figure 6. These points are shown as "A", "B" and "C" on schematic. To make adjustment, connect plug-in focus lead to either of the three focus pins, whichever provides best focus at central area of picture tube. Important: Focus adjustment should be made with controls set for picture with normal contrast and brightness.

Caution: High B+ potential is present at focus terminals. To prevent electric shock, use care to avoid accidental contact with focus terminals.

VOLUME TV-24, ADDITIONAL 1965 TELEVISION SERVICING INFORMATION

ADMIRAL C21 Chassis Group, Tuner Diagrams, Continued

VHF TUNER 94E243-12

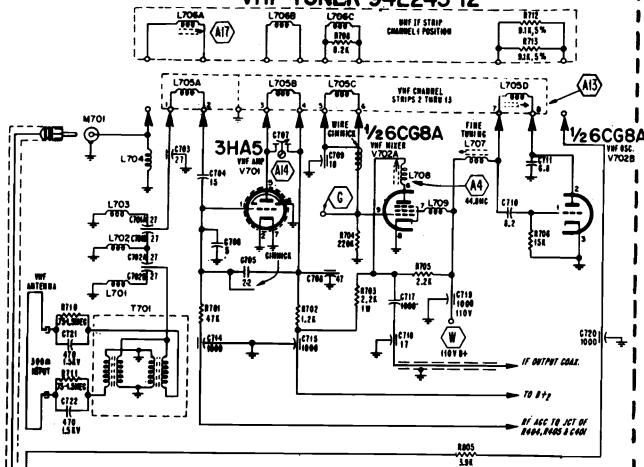

UHF TUNER 94D233-9

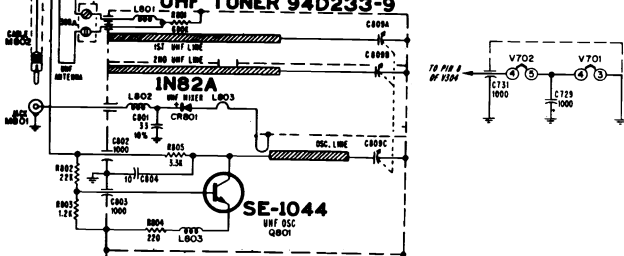

ALTERNATE TUNERS FOR C21B12-1H CHASSIS

VHF TUNER 94D260-3

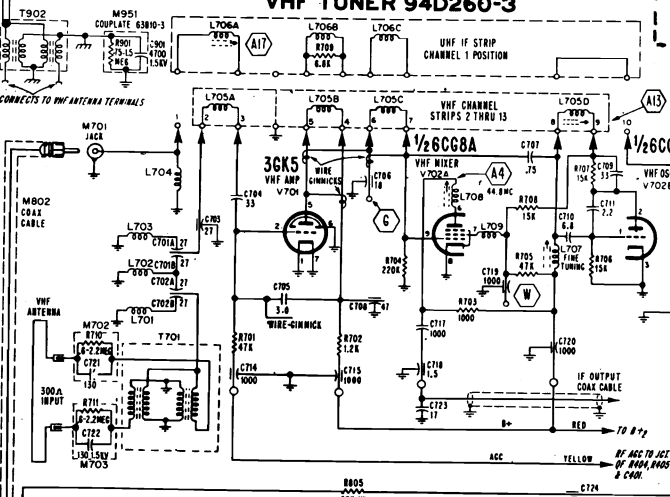

UHF TUNER 94D233-3

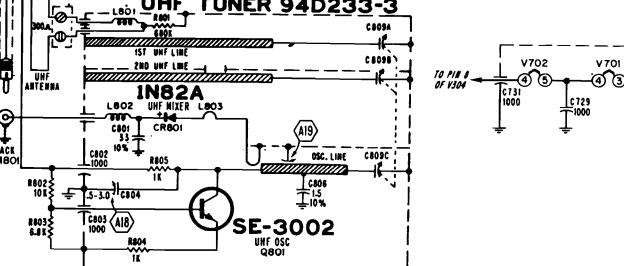

ALTERNATE TUNERS FOR C21B12-1G & C21C13-1 CHASSIS

VHF TUNER 94D260-3

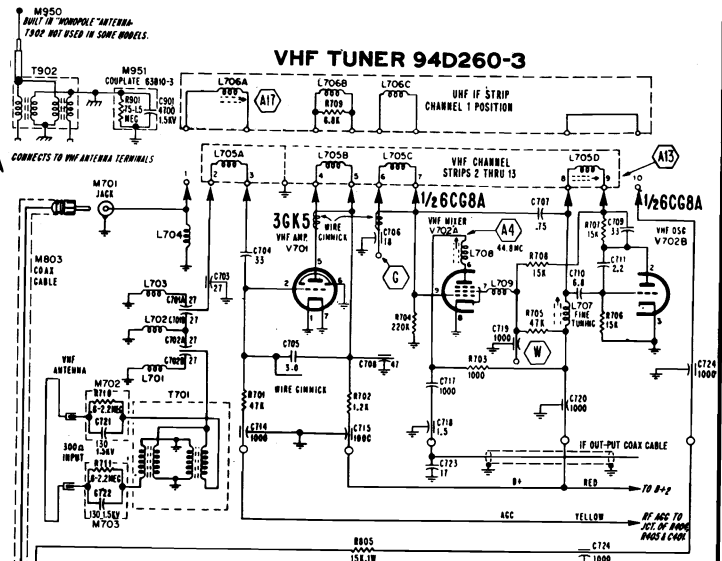

UHF TUNER 94D233-9

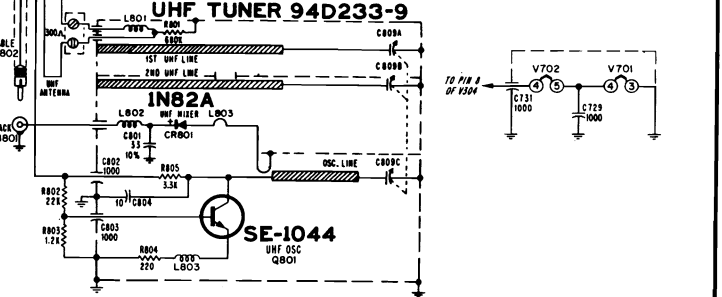

ALTERNATE TUNERS FOR C21B12-1R & C21C15-1 CHASSIS

VHF TUNER 94E243-12

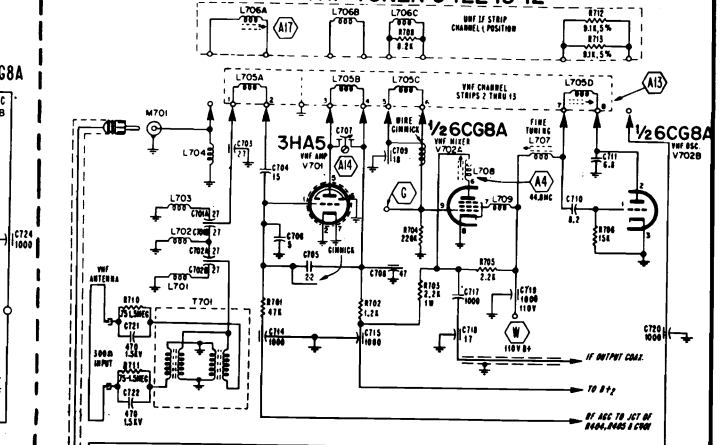

UHF TUNER 94D266-1

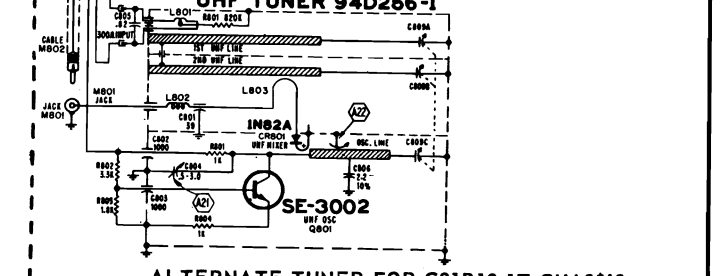

ALTERNATE TUNER FOR C21B12-1T CHASSIS

Admiral

**D7, 1D7
CHASSIS**

1D7 CHASSIS TILT-OUT ASSEMBLY REMOVAL

To remove tuners and control assembly:

1. Pull off all knobs on tilt-out panel.
2. Remove cabinet back and unplug tuner IF coax lead at chassis.
3. Disconnect the white plug connecting the tuner assembly wires to the chassis.
4. Disconnect the contrast control cable by pulling connector from end of control shaft.
5. Disconnect spring A from bracket on inside of cabinet front. (See fig. B below for the remaining steps).
6. Remove screws B & C.
7. Remove screw D located between the tuners.
8. Remove screws E & F while supporting tuner assembly. Ease tuner assembly off centering pins, then down and out. Screws G, H & I retain the control cluster bracket.

To remove tilt-out escutcheon assembly:

9. Remove the screw that fastens ground lug J to the picture tube escutcheon.
10. Remove retaining rings at pivot point K & L. Lift assembly carefully up and out from front of cabinet.

| MODEL CHART | | | | |
|-------------|--------|----------|---------|------|
| MODEL | FINISH | TILT-OUT | CHASSIS | SIZE |
| LDU3445 | Maple | No | D761-1 | 23" |
| LDU3449 | Cherry | No | D761-1 | 23" |
| LDU3461 | Walnut | No | D761-1 | 23" |
| LDU3465 | Maple | No | D761-1 | 23" |
| LD5001 | Walnut | No | 1D761-1 | 25" |
| LD5011 | Walnut | Yes | 1D760-1 | 25" |
| LD5021 | Walnut | Yes | 1D760-1 | 25" |
| LD5025 | Maple | Yes | 1D760-1 | 25" |
| LG5201 | Walnut | Yes | 1D760-1 | 25" |
| LD5205 | Maple | Yes | 1D760-1 | 25" |

GENERAL

The chassis covered by this manual are basically the same and are generally referred to as the D7 and 1D7. The other chassis numbers identify the various cluster control assemblies.

Both chassis have 3 IF stages, power transformer, preset fine tuning, width and focus adjustments. The D7 chassis uses a 23" picture tube. LD5001 and all 23" models use conventional control assemblies.

All 25" picture tube models with the exception of LD5001 use the unique tilt-out control assembly (See figure A). The tilt-out panel is pivoted out on the top edge with the finger tips for access to controls. The tilt-out assembly can then be pivoted back in allowing the illuminated channel numbers to show from the front.

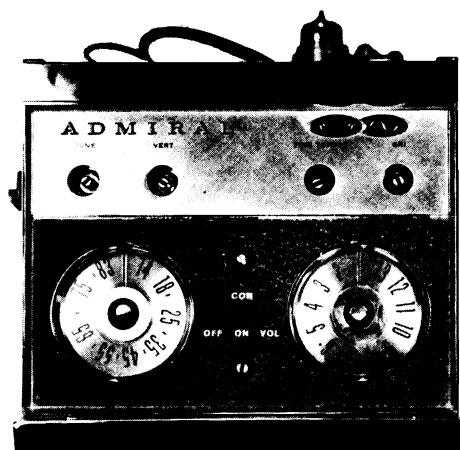

CORRECT LOCATION OF UHF INDICATOR DRUM ON TUNER SHAFT WHEN UHF TUNER IS AT END OF RANGE. CORRECT LOCATION OF VHF INDICATOR DRUM

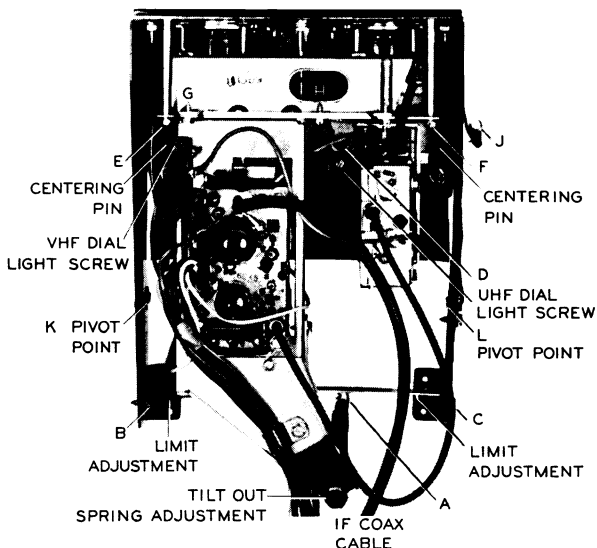
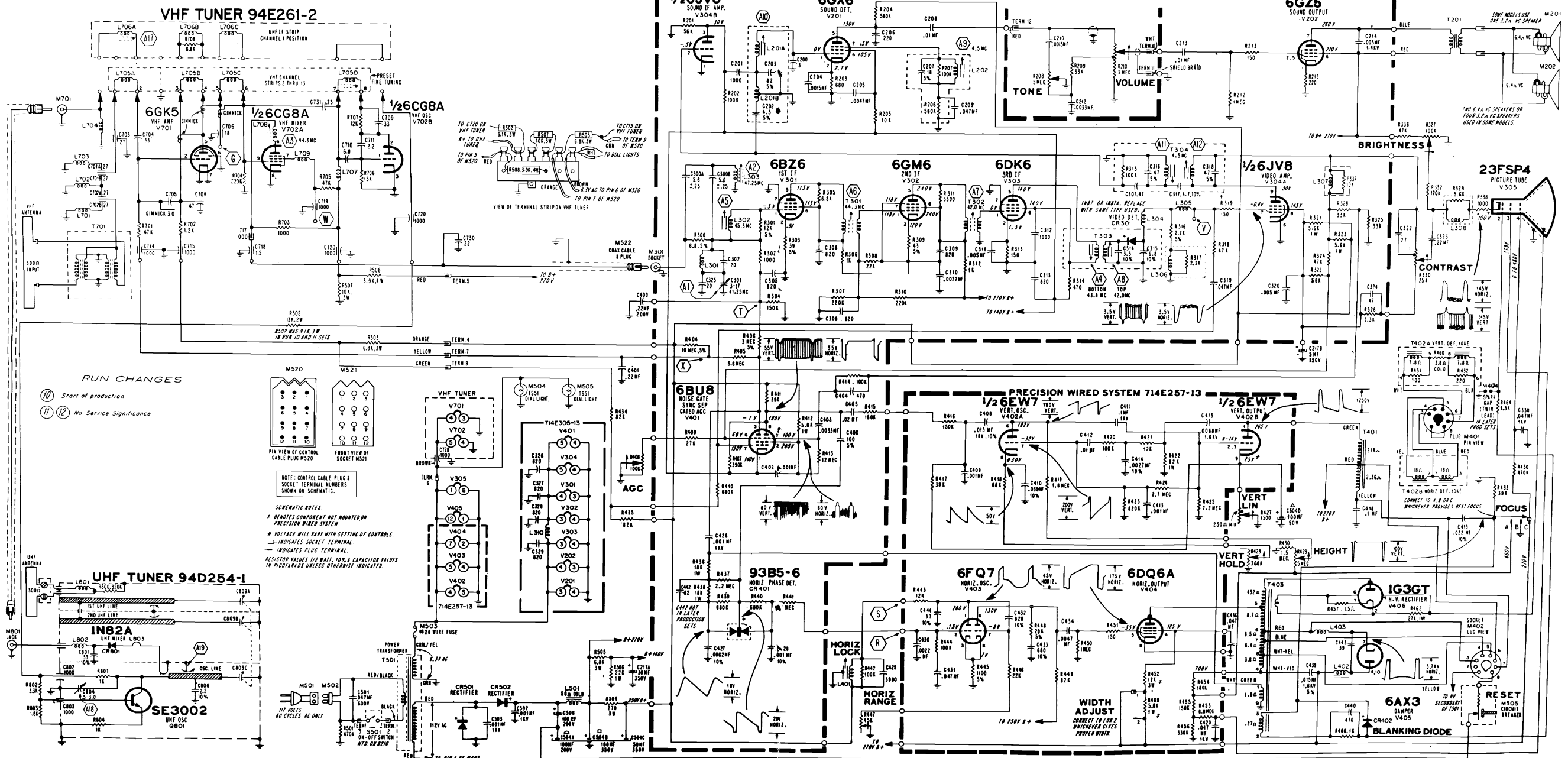

Fig. B 1D7 Tilt-Out Assembly Top View

Fig. A 1D7 Tilt-out Assembly Front View

ADMIRAL Chassis D761-1 Schematic Diagram

ADMIRAL Chassis D761-1 Schematic Diagram, Continued



D761-1 CHASSIS SCHEMATIC DIAGRAM

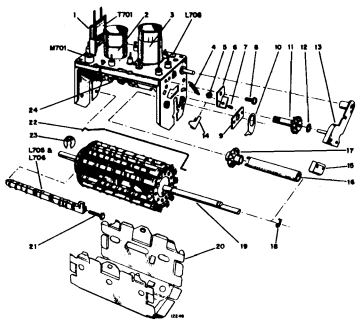

Exploded view of 94E261-2 & -3 Tuner

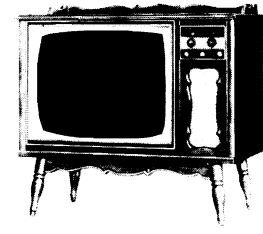

LDU3445

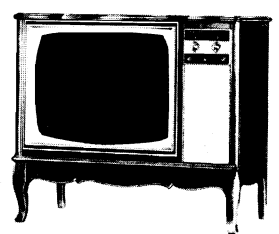

LDU3449

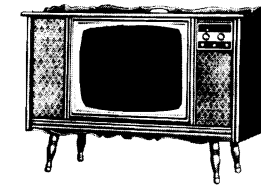

LDU3465

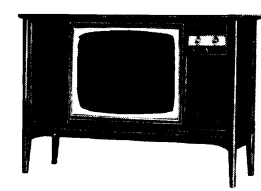

LDU3461

VOLUME TV-24, ADDITIONAL 1965 TELEVISION SERVICING INFORMATION

ADMIRAL Chassis 1D760-1, 1D761-1, Schematic Diagram

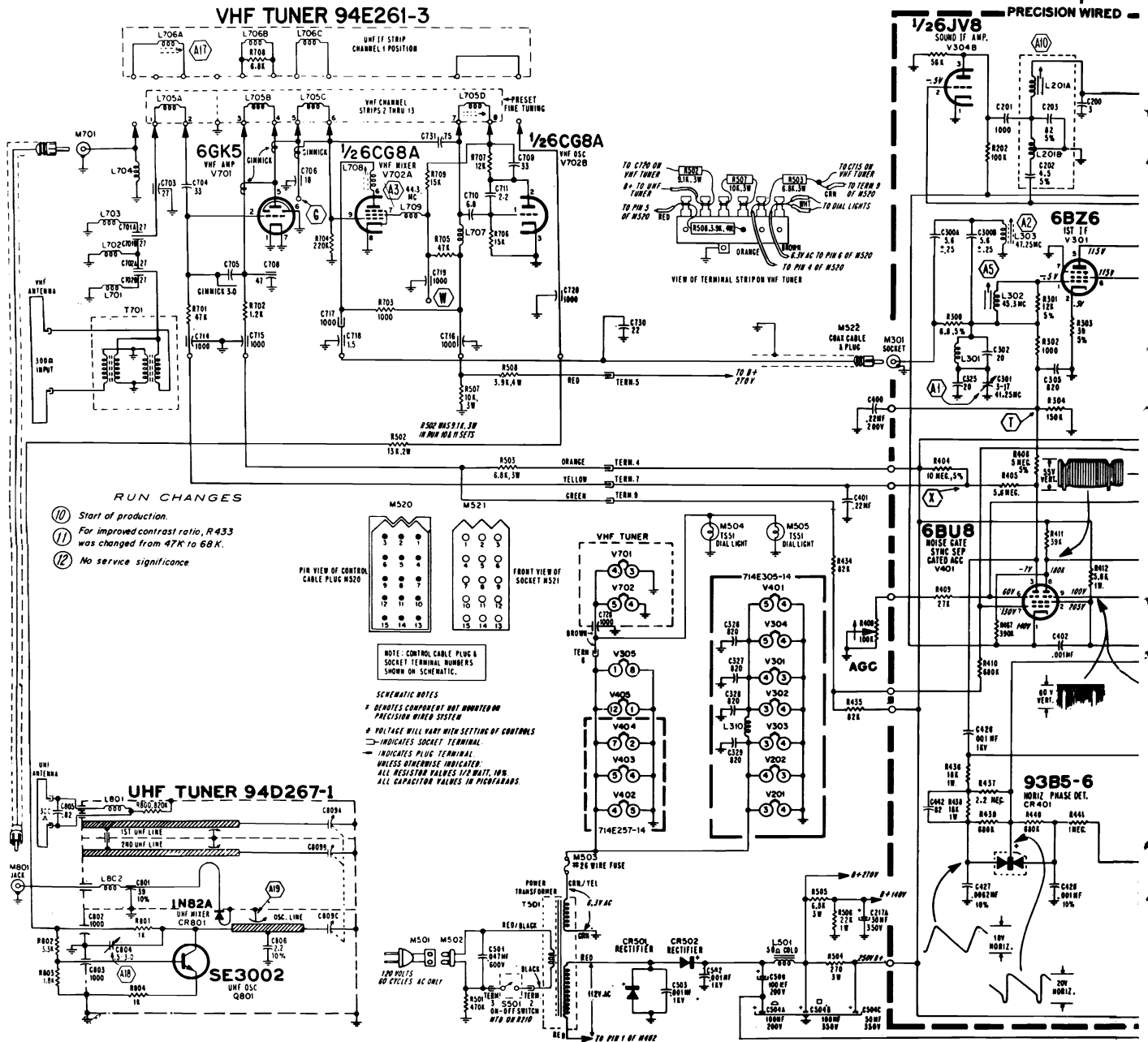

1D761-1 & 1D760-1 CHASSIS SCHEMATIC DIAGRAM

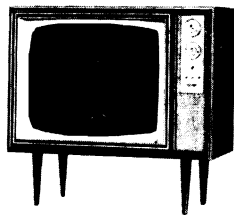

LD5001

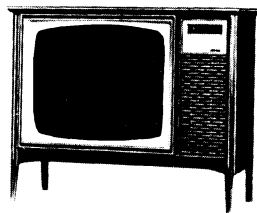

LD5011

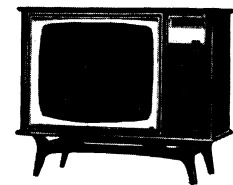

LD5021

VOLUME TV-24, ADDITIONAL 1965 TELEVISION SERVICING INFORMATION

ADMIRAL Chassis 1D760-1, 1D761-1, Schematic Diagram, Continued

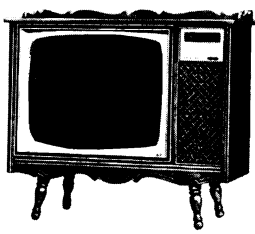
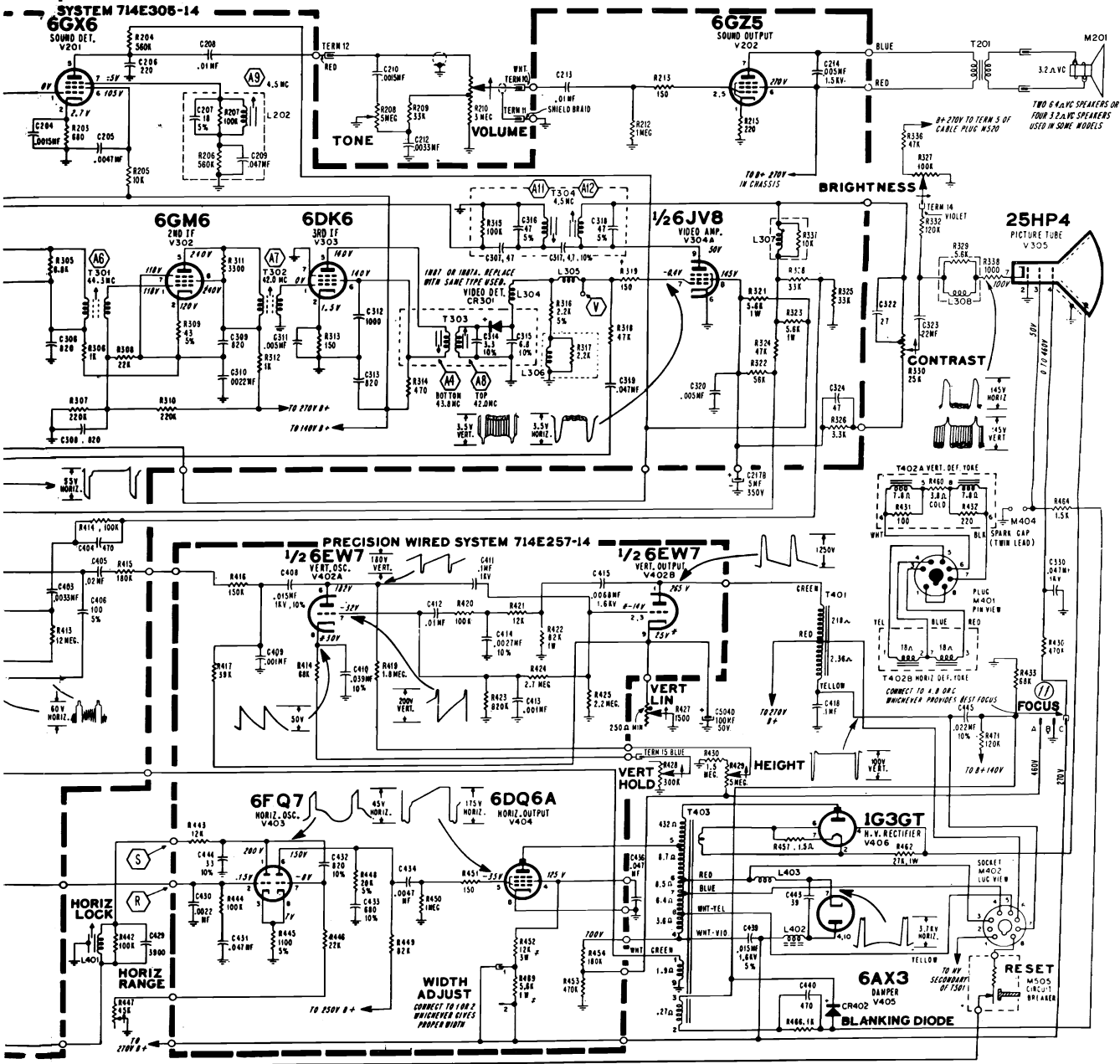

LD5025

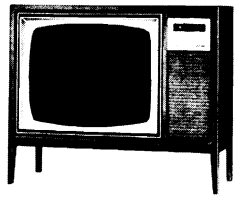

LG5201

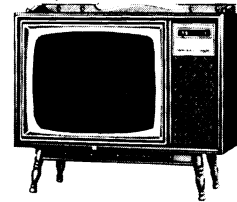

LG5205

ADMIRAL Chassis D761-1, 1D760-1, 1D761-1, Adjustments, Continued

PRESET FINE TUNING OR OSCILLATOR ADJUSTMENT

All models are equipped with a VHF tuner having preset fine tuning for each VHF channel. Adjust the fine tuning knob for best picture consistent with good sound after the set has warmed up for five minutes. Repeat this procedure for each used VHF channel. There is no other oscillator slug adjustment.

RASTER TILT ADJUSTMENT

If raster is tilted, loosen deflection yoke clamping screw at rear of yoke. Rotate yoke until raster is straight. Tighten yoke clamping screw. CAUTION: Do not allow yoke to move back or forward on neck of picture tube.

PICTURE CENTERING

The picture may be centered vertically and/or horizontally by moving the centering tabs, which are located on the back of the deflection yoke assembly.

AGC CONTROL ADJUSTMENT

The AGC control is an AGC threshold control which is used solely to adjust the receiver for optimum operation under all signal conditions.

Note: This control is set at the factory and will not normally require field readjustment.

Improper AGC control adjustment can result in picture bending, tearing (overloading) or buzz in the sound. However, these same conditions can also be caused by other troubles in the set. Make adjustment as follows:

1. Turn set on and allow 15 minutes to warm up.
2. Turn Channel Selector to strongest station in the area.
3. Turn Contrast and Brightness controls fully to the right.
4. Very slowly turn AGC control to the left, just to the point where picture is weak (loses contrast).
5. Adjust Horizontal Lock (at rear of set) and Vertical Hold control (at side of set) for steady picture, without bending of vertical lines at top of picture.
6. Very slowly turn AGC control to the right, until picture just begins to bend, tear, shift, or buzz is heard in sound. Then very slowly turn the AGC control to the left, to the point at which picture bending, tearing, shifting and buzz is removed.
7. Make final adjustment by turning AGC control an additional 10 degrees to the left.
8. Recheck at maximum contrast on all channels. Picture should not overload and should reappear immediately after changing channels.

IMPORTANT: AGC adjustment should always be made on the strongest TV station received. If adjustment is made only on a weak station, AGC overload may occur when a strong TV station is tuned in.

HORIZONTAL LOCK ADJUSTMENT

Make adjustment if picture "slips sideways" or "tears" when switching channels. Adjustment is made by rotating flexible shaft extending from rear of set. Adjust as follows:

1. Allow a few minutes for set to warm up. Tune in weakest station, set Brightness and Contrast controls for normal Picture. Important: Before proceeding, be sure that AGC control has been adjusted according to instructions in this manual.
2. Reduce Contrast to minimum. Very slowly turn Horizontal Lock adjustment to the right or left until picture is in sync. Interrupt the television signal by switching Channel Selector off and on channel. Picture should remain in sync. If picture bends or loses sync, adjust Horizontal Lock so that picture remains in sync and bending of vertical lines does not appear at top of picture. Check adjustment on all channels.

IMPORTANT: If adjustment cannot be made using the Horizontal Lock control, it will be necessary to make Horizontal Range adjustment as instructed below.

HORIZONTAL RANGE ADJUSTMENT

The Horizontal Range control is set at the factory and seldom requires readjustment. Adjustment need only be made if 6FQ7 tube (V403) has been replaced and the picture cannot be locked-in with the Horizontal Lock adjustment or if the Horizontal Lock adjustment has insufficient range (adjustment only possible at extreme end rotation). Note: Horizontal Range adjustment is accessible after removing cabinet back.

Caution: Before proceeding with adjustment, be sure that the picture will sync vertically, as lack of both vertical and horizontal sync indicates sync circuit trouble. Lack of only horizontal sync generally indicates trouble in the horizontal sync (phase detector) circuit. Adjust as follows:

1. Remove cabinet back. Connect interlock cord.
2. Allow a few minutes for set to warm up. Tune in weakest station, set Brightness and Contrast controls for a normal picture. Important: Before proceeding, be sure that the AGC control has been adjusted according to instructions in this manual.
3. Using a piece of hook-up wire, short test point "R" (pin 2 of V403, 6FQ7 tube), to chassis ground. See schematic for test point locations.
4. Connect a .22 mf 400 volt capacitor from test point "S" (junction of horizontal lock coil L401 and resistor R443, 100K) to chassis ground. Caution: To avoid B+ shock, turn receiver off when making this connection.
5. With picture in vertical sync, set Horizontal Range control at point where picture is in horizontal sync and almost remains stationary with tendency to shift to left or right.
6. Remove the .22 mf capacitor from the horizontal lock coil. Set horizontal lock coil at point where picture is in horizontal sync and almost remains stationary with tendency to shift to left or right.
7. Remove wire short from test point "R". Set Channel Selector to weakest station. Switch Channel Selector on and off channel, picture should remain in horizontal sync. If necessary, adjust horizontal lock coil slightly to bring picture in sync.

HEIGHT AND VERTICAL LINEARITY ADJUSTMENT

If the picture is of incorrect height (vertical size), adjust the Height control. This adjustment may affect the vertical linearity of the picture. If necessary, alternately adjust the Vert. Lin. control and Height control. Note: Upper portion of the picture is affected mostly by the Vertical Linearity control; lower portion by the Height control.

IMPROVING FOCUS

The picture tube of these receivers utilizes electrostatic focus in connection with a three position focus adjustment.

For obtaining best overall sharpness of pictures, focus adjustment should be checked at installation and when servicing. Once focus adjustment is properly made, no further need for readjustment is required.

From rear view of chassis (See fig. G) note that there are three focus (pin) connections at top rear of the chassis board, points shown as "A", "B" and "C". To make adjustment, connect plug-in focus lead to either of the three focus pins, whichever provides best focus at central area of picture tube. Important: Focus adjustment should be made with controls set for picture with normal contrast and brightness.

Caution: High B+ potential is present at focus terminals. To prevent electric shock, use care to avoid accidental contact with focus terminals.

WIDTH ADJUSTMENT

The figure G shows the location of 2 width pins on the rear apron of the chassis. Note: On early production chassis there are 3 pins on the terminal strip. The one to the far left is not a width pin and the pin should be taped to avoid use. Turn the set off before taping this pin.

Facing the rear of the chassis the right-hand pin gives minimum width. Plug the jumper wire on to the pin which gives a full raster with a slight horizontal over scan. Avoid touching the pin as they are at B plus potential.

ADMIRAL Chassis D761-1, 1D760-1, 1D761-1, Alignment, Continued

IF ALIGNMENT

If only touch-up on check of IF curve is needed, then start with sweep alignment.

Short the antenna terminals together and connect -5 volt bias supply to test points T and X positive to chassis (See figure G).

When adjusting IF transformers, keep reducing generator output to prevent VTVM, reading from exceeding 2 volts over the residual voltage. Use needle nose alligator clip or looped end of hookup wire, connect signal generator high side to test Point "G" low side directly to tuner (See figure E).

Connect VTVM high side to test point "V" through decoupling filter shown in figure C, low side to chassis.

Remove V404 horizontal output tube.

Allow 15 minutes for receiver and test equipment to warm up. Use non-metallic alignment tool part no. 98A30-12 & 98A30-14.

Important: Before proceeding, check signal generator against crystal frequency standard for calibration.

1. Set generator at 41.25MC and adjust A1 for **MINIMUM**. If necessary, increase generator output or reduce bias to negative 1½ volts to obtain a definite indication on VTVM when adjusting the traps.
2. Set generator at 47.25MC and adjust A2 for **MINIMUM**.
3. Connect jumper across R301.
4. Set generator at 44.3MC and adjust A3 for maximum.
5. Remove jumper used in step 3.
6. Set generator at 44.3MC and adjust A6 for maximum.
7. Set generator at 45.3MC and adjust A5 for maximum.
8. Set generator at 43.8MC and adjust A4 for maximum.
9. Set generator at 42.0MC and adjust A7 for maximum.
10. Set generator at 42.0MC and adjust A8 for maximum.
11. Proceed with necessary sweep alignment.

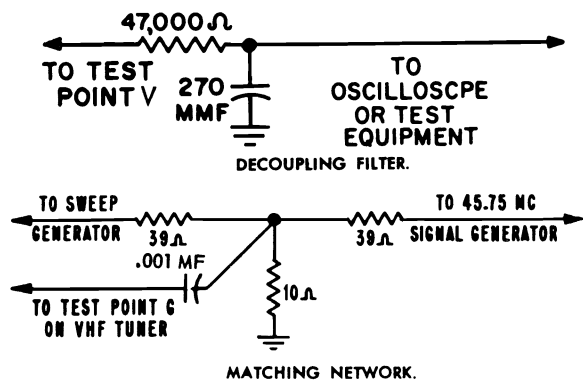

Figure C Alignment Networks

IF SWEEP ALIGNMENT

1. Disconnect RF generator from "G" and connect sweep generator high side to test point "G" through network shown in figure C, low side directly to tuner (See figure E). Set sweep frequency to 43MC, sweep width approximately 7MC. If external marker generator is used loosely couple high side to sweep generator lead, low side directly to tuner. Marker frequencies are indicated on IF Response Curve, see figure D.
2. Disconnect VTVM and connect oscilloscope high side to test point "V" through a decoupling filter (figure C), low side to chassis. Set channel selector to channel 12 or other high unused channel where the fine tuning does not affect the curve.

3. Maintain sweep voltage to provide 3 volts peak to peak on oscilloscope, check curve obtained against ideal response, see figure D. Keep marker outputs as low as possible. Slightly readjust A7 to give round nose to curve and slightly readjust A4 to properly locate 45.75MC marker.
4. Recheck and adjust if necessary 41.25MC and 45.25MC traps (A2 and A1). Decrease bias to 1 volt and increase marker output and scope gain if necessary to see marker and base line.

VHF AMPLIFIER AND MIXER ALIGNMENT

The tuners are turret types that feature high stability and trouble-free operation. The inductors of this tuner consist of individual channel strips and in general RF and mixer alignment is permanent. Individual channel oscillator slugs are adjusted by the fine tuning knob. See figure E for tuner adjustment locations. If it is definitely determined that complete tuner alignment is required, return tuner to Admiral Distributor for repair or replacement.

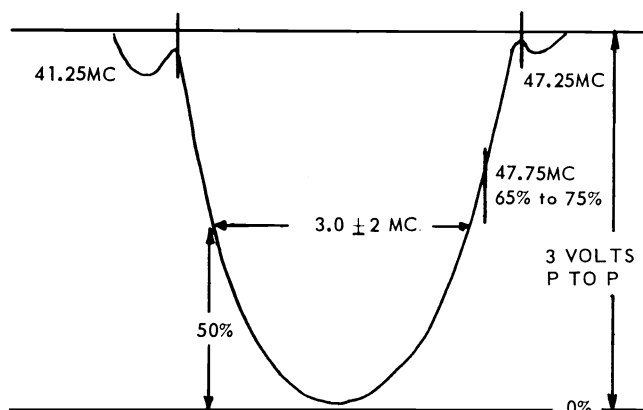

Figure D Ideal IF Response Curve

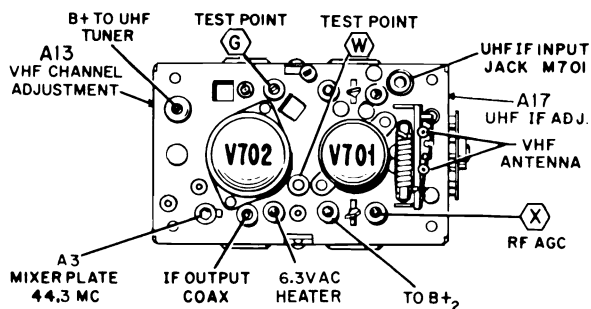

Figure E Top view of VHF Tuner

OVER-ALL VHF AND IF RESPONSE CURVE CHECK

Set AGC control fully to the left. Channel Selector on channel 12. Connect negative of 3V bias supply to test points "T" (IF AGC) and "X" (RF AGC), positive to chassis. See figure G.

Important: Before proceeding check signal generator against frequency standard for calibration.

Attach the sweep generator at the VHF tuner antenna terminals, high side through 1200 ohm resistor, low side through 1200 ohm resistor. Place a 330 ohm resistor across the antenna terminals and a 47 ohm resistor across the generator output.

ADMIRAL Chassis D761-1, 1D761-1, 1D760-1, Alignment, Continued

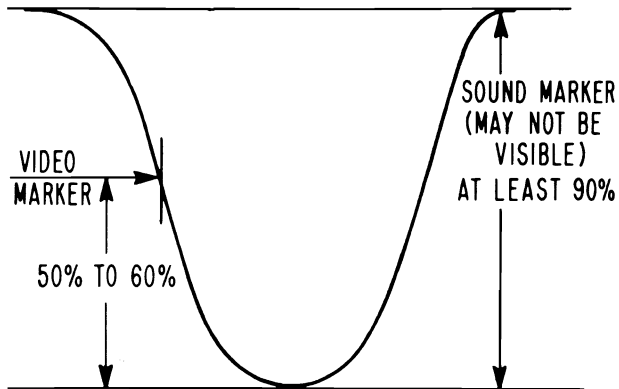

Figure F. Ideal Over-all VHF and IF Response Curve.

Connect oscilloscope high side to test point "V" through decoupling filter, low side to chassis.

Compare the response obtained to the ideal curves shown above. If curve is not within tolerance slightly adjust the IF transformers to obtain the correct curve. It should never be necessary to turn the slug more than one turn in either direction. If curve is satisfactory on channel checked, all other channels should be satisfactory. **IMPORTANT:** When sweep output is reduced, response curve amplitude on scope should also decrease, but curve shape should remain the same. If curve shape changes, reduce sweep output and/or scope gain until shape does not change.

ALIGNMENT OF UHF IF INPUT USING A TRANSMITTED SIGNAL

Alignment of UHF IF input coil (part of VHF tuner), should be made if UHF reception is poor and after usual causes of poor UHF reception have been checked.

To align UHF IF input coil, tune in UHF channel with normal picture and sound. Using non-metallic alignment tool very carefully adjust slug A17 for best picture, consistent with good sound. For VHF tuner adjustment locations, see figure E.

4.5 MC SOUND IF ALIGNMENT

1. Tune in normal picture on strongest TV station. Allow about 15 minutes for set to warm up. See figure G for adjustment locations.

*2. Using non-metallic alignment tool (part no. 98A30-12), slowly turn slug "A9", several turns to left until a buzz is heard in sound. Then slowly turn slug "A9" to the right for loudest and clearest sound. **NOTE:** There may be two points (approx. 1/2 turn apart) at which sound is loudest. The slug should be set at center of second point of loudest sound noted as slug is turned in (toward bottom of coil).

3. Reduce signal to antenna terminals until there is considerable hiss in sound. For best results, use a step attenuator, connected between antenna and antenna terminals. Signal can also be reduced by disconnecting antenna and placing it close to antenna terminals or leads.

4. Carefully adjust slug "A10" for loudest and clearest sound with minimum hiss. If hiss disappears during alignment, reduce signal to maintain hiss level. Readjust slug "A9". **NOTE:** Slug "A9" should be at end nearest bottom of coil.

5. Carefully adjust slug "A11" for loudest and clearest sound with minimum hiss. If hiss disappears during alignment, reduce signal to maintain hiss level. Readjust slug "A11". **Caution:** Slug "A11" is located nearest bottom of shield can. Use care so as not to disturb slug nearest top of coil.

6. If above alignment is correctly made, no further adjustment is required. However, if sound remains distorted at normal volume level (when receiver is tuned for best sound), repeat entire procedure.

* **CAUTION:** Do not readjust slug "A9" unless sound is distorted. If "A9" is readjusted, all steps in alignment procedure should be repeated exactly as instructed.

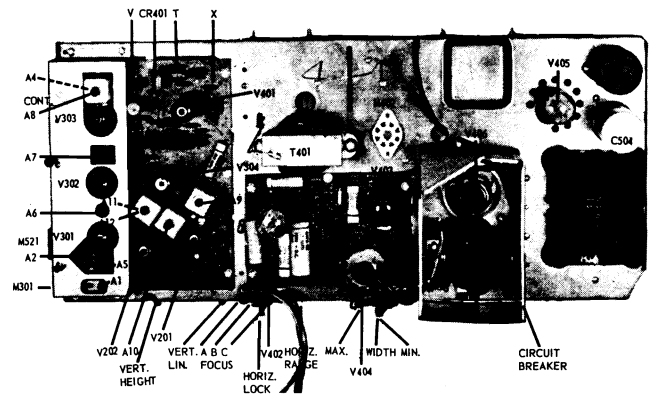

Figure G Top view of Chassis showing Alignment Locations. Dashed lines indicate adjustment nearest chassis.

ALIGNMENT OF 4.5 MC TRAP

Alignment of 4.5 MC (beat interference) trap "A12" requires use of a hexagonal non-metallic alignment tool (part number 98A30-12).

To align 4.5 MC trap "A12", tune in television station with beat interference pattern in picture. While closely observing picture, adjust slug "A12" for minimum interference pattern.

Note that adjustment "A12" is top slug (slug farthest from bottom of coil). Use caution so as not to disturb bottom slug (slug nearest bottom of coil) as sound IF alignment will be affected.

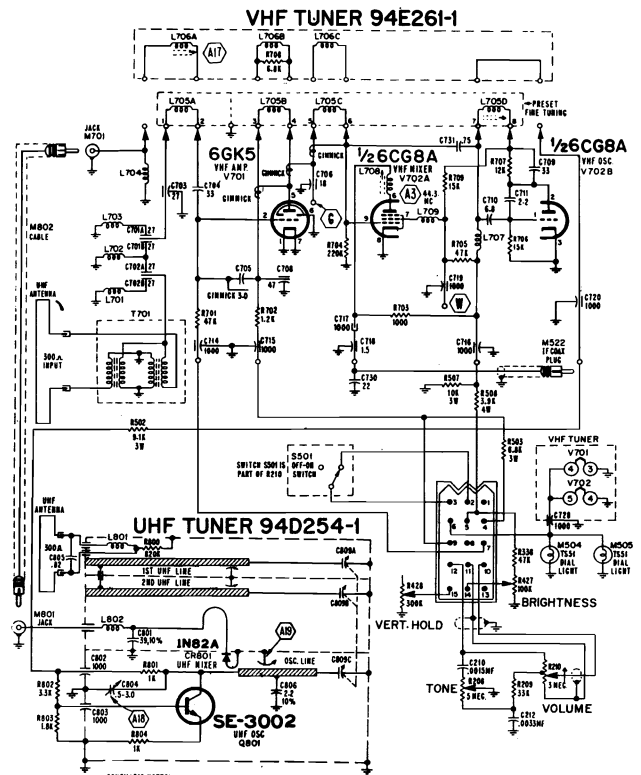

DELMONICO

MODELS TVM-11, TVM-33

(Factory service material on pages 23 through 28)

PICTURE TUBE AND PROTECTION GLASS CLEANING

Remove five screws fastening the front cover, pull the bottom part forward and raise it to take off the front cover. Always keep the picture tube and the protection glass clean.

AGC CONTROL

To adjust the AGC control, set other operating controls for normal operation. Set CHANNEL SELECTOR to the strongest channel in your area. Adjust AGC control clockwise until overload occurs. Turn the control at the back of set until overload disappears. Check other channels for overload and readjust the control if necessary.

VHF OSCILLATOR ADJUSTMENT

Set CHANNEL SELECTOR to the highest channel in the area. Pull out CHANNEL SELECTOR knob and FINE TUNING knob. Set the position of FINE TUNING knob.

Then adjust the oscillator coil's adjusting screw with a screwdriver.

After adjusting the channel for the best picture and sound, adjust lower channel successively. Do not rotate FINE TUNING knob during the adjustment.

ADJUSTMENT FOR NON-OPERATING CONTROLS

The AGC, HEIGHT and V. LIN. can be adjusted with screwdriver through the rear cover.

HORIZONTAL OSCILLATOR ADJUSTMENT

Turn the H. HOLD control to the extreme clockwise position. The picture should be out of sync. with bars slanting downwards to the right. Adjust the Hor. Freq. adjustment core which is the outside of the Hor. Osc. Transformer T401, so that about 5 diagonal black bars are obtained. With higher frequencies, the circuit may cause double triggering.

The H. HOLD control can be rotated to the extreme clockwise or counter-clockwise position.

FUSE

2 amp. fuse is used, do not use other one.

FOCUS ADJUSTMENT

The FOCUS may be varied in steps by the position of the plug P5 in the Focus Adjustment Board J5.

CENTERING ADJUSTMENT

Rotate the two magnetic rings around the neck of picture tube until picture is properly centered.

UHF DIAL ROPE WINDING METHOD

1. Rotate UHF CHANNEL INDICATOR counterclockwise and the dial cord drum at UHF tuner clockwise, until they stop.
2. Wind the dial cord $1\frac{1}{2}$ turn around the gear at VHF tuner and $2\frac{1}{2}$ turns around the dial cord drum at UHF tuner. Then fasten the dial cord to the dial cord drum by spring like Fig. 1.

CHECK WARNING

If the filaments are on and the set is in no raster failure, check quickly the pin 5 of V13 Hor. Sweep Output Tube 12DQ6A. If 25V or any negative voltage cannot be noticed, make the power off and check the preceding circuit of V13 or B line. Otherwise, serious damages may be caused.

VOLUME TV-24, ADDITIONAL 1965 TELEVISION SERVICING INFORMATION

DELMONICO Models TVM-11, TVM-33, Schematic Diagram

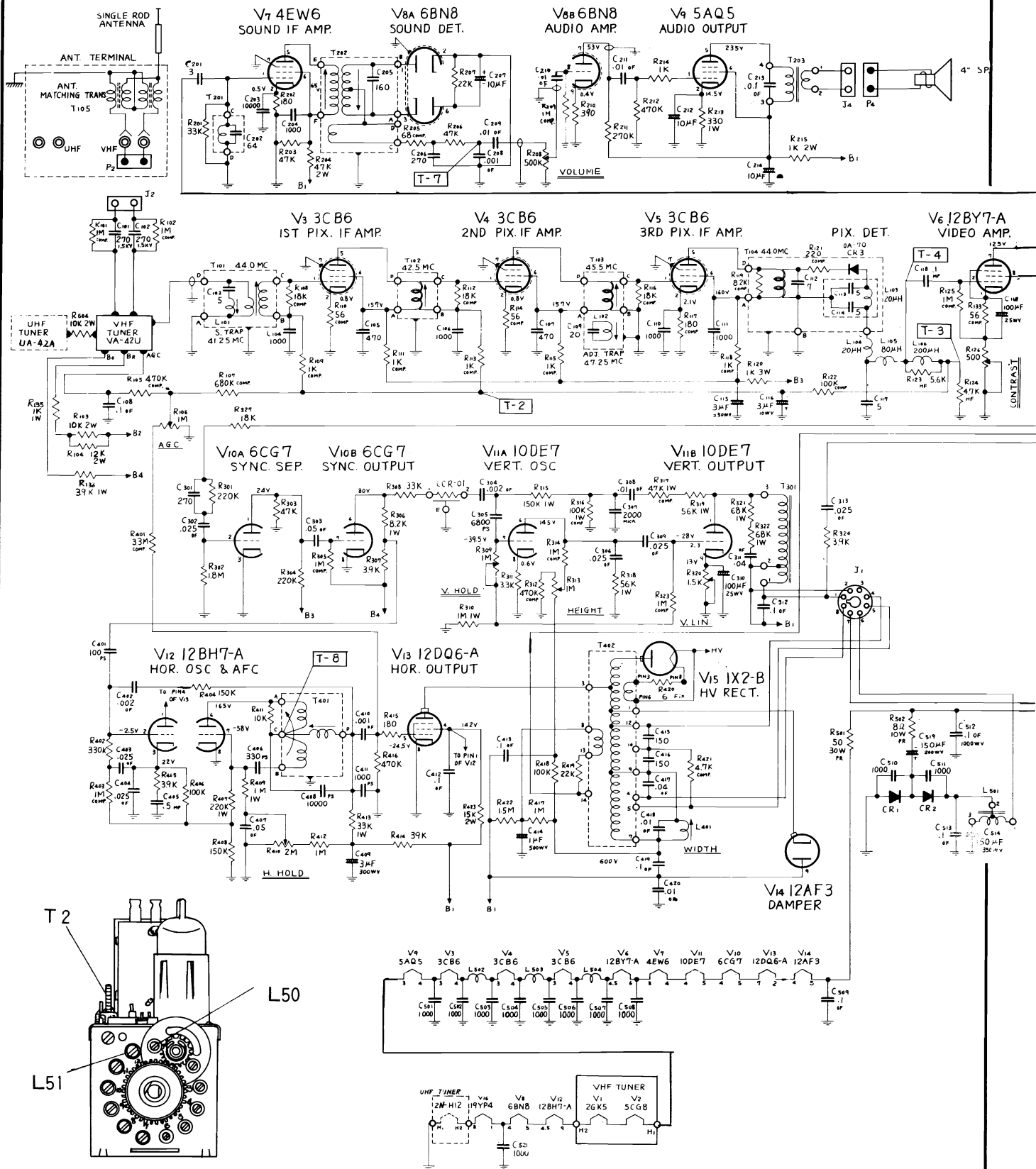

Fig. 5

VOLUME TV-24, ADDITIONAL 1965 TELEVISION SERVICING INFORMATION

DELMONICO Models TVM-11, TVM-33, Continued

DISASSEMBLY INSTRUCTIONS

CHASSIS REMOVAL

When the chassis is taken out, the cabinet is apt to fall forward. So be sure to require an adequate support for the cabinet.

1. Remove 2 single knobs and 1 dual knob on the top, and 3 knobs on the side.
2. Remove 8 screws fastening the rear cover and take it off after disconnecting antenna leads.
3. Disconnect yoke leads and picture tube socket.
4. Remove 5 screws fastening chassis from both top and bottom of cabinet.
5. After pulling out chassis a little, disconnect the anode cap of picture tube, then remove chassis.

PICTURE TUBE REMOVAL

Remove the picture tube from the front.

1. Remove 5 screws fastening front cover.
2. Pull the bottom part of front cover slightly and raise it, then front cover will be taken off.
3. Remove the rear cover.
4. Disconnect the socket of picture tube.
5. Loosen the yoke clamp and remove the yoke.
6. Remove 4 hexangular nuts and washers holding picture tube mounting-brackets.
7. Pull picture tube slightly and remove the anode cap, then picture tube can be taken off.

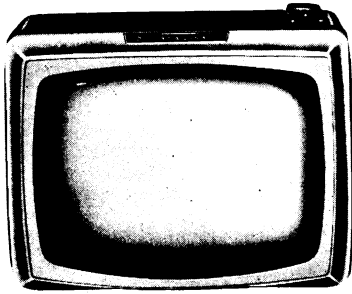

MODEL TVM-11

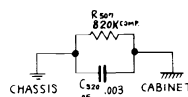
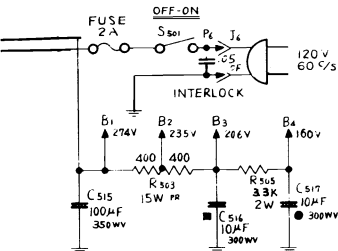
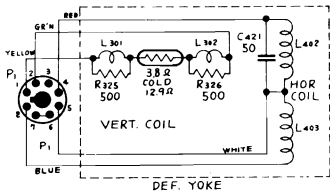
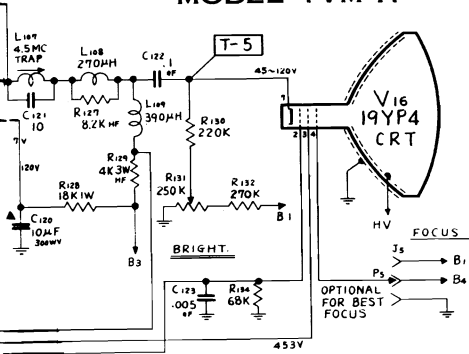

NOTES:

All DC voltages measured with VTVM and with no signal input.

All resistance values are in ohms.

K: 1,000 M: 1,000,000

All capacitance values less than 1 are in MF and above 1 are in MMF unless otherwise indicated.

Unspecified resistor are carbon resistor 1/2 Watt.

COMP.: composition resistor

PR: porcelain resistor

Unspecified capacitors are ceramic capacitors.

MP: metallized capacitor

OF: oil filled capacitor

PA: paper capacitor

PS: polystyrol capacitor

Fuse type: Regular

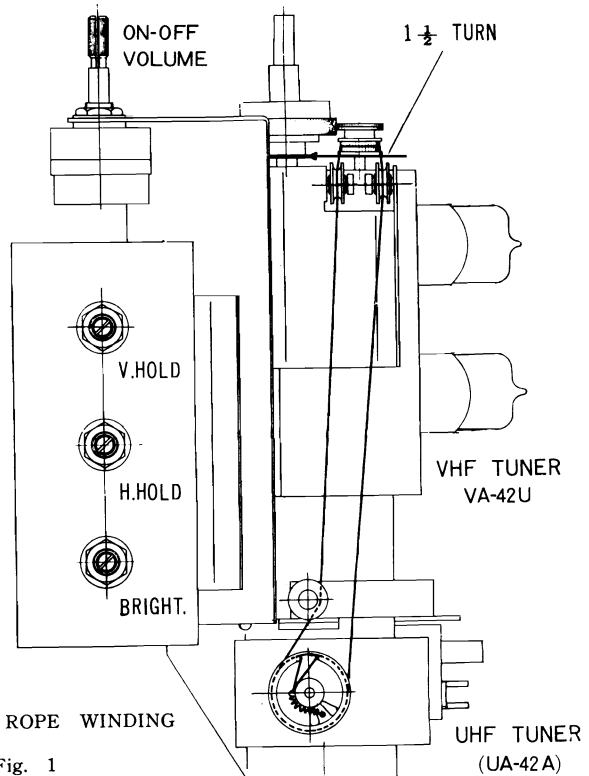

Fig. 1

DELMONICO Models TVM-11, TVM-33, Alignment Information, Continued

VIDEO IF ALIGNMENT

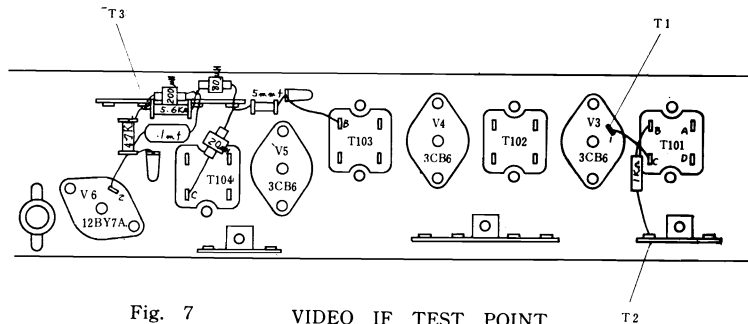

Fig. 7 VIDEO IF TEST POINT

1. Test Equipments

- Oscilloscope
- IF Sweep Generator
- Marker Generator

2. Stagger Stage Alignment

Set the channel selector of VHF tuner to channel 13.

Connect the output of sweep generator to T1, and connect oscilloscope to T3.

Apply -3 volts between T2 and the chassis and lightly couple the marker generator with the output of sweep generator. Adjust each IF transformer and coil so that the frequency will be maximum respectively and the response will be like Fig. 8 according to chart 3.

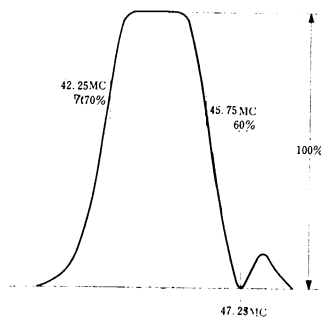

Fig. 8 STAGGER WAVE FORM

IF Transformer and coil to be adjusted

Frequency to be adjusted to maximum or minimum

| | |
|----------------|---------------|
| T102 (inside) | 39.75 Mc min. |
| T103 (inside) | 47.25 Mc min. |
| T102 (outside) | 42.5 Mc max. |
| T103 (outside) | 45.5 Mc max. |
| T104 (outside) | 44.0 Mc max. |
| T102 (outside) | 42.25 Mc 70% |
| T103 (outside) | 45.75 Mc 60% |

Chart. 3

3. IF Overall Alignment

Remove the output of sweep generator from T1 and connect this output with the VHF tuner's test point TP. Adjust the VHF tuner T2 and the IF transformer T101 according to Chart 4, so that the response will be like Fig. 9.

The VHF tuner's TP & T2 are illustrated in Fig. 5.

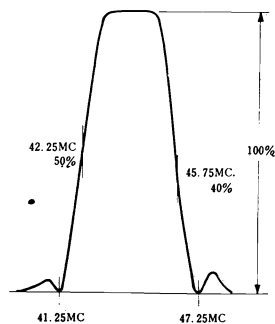

Fig. 9 OVER ALL WAVE FORM

IF Transformer and coil to be adjusted

Frequency to be adjusted

| | |
|--------------------|---------------|
| T101 (inside) | 41.25 Mc min. |
| T2 (VHF tuner) | 44.0 Mc max. |
| T101 (outside) | 44.0 Mc max. |
| T2: T101 (outside) | 42.25 Mc 50% |
| T2: T101 (outside) | 45.75 Mc 40% |

Chart 4

VOLUME TV-24, ADDITIONAL 1965 TELEVISION SERVICING INFORMATION

DELMONICO Models TVM-11, TVM-33, Alignment Information, Continued

4.5Mc TRAP ALIGNMENT

1. Test Equipments

4.5Mc Oscillator

VTVM with RF probe

2. Alignment

Connect oscillator to test point T4 on the video circuit and connect RF probe of VTVM with T5. Adjust L107 so that VTVM needle will indicate minimum. In this case, it is better that 4.5 Mc signal input is as large as possible and VTVM voltage range is as small as possible.

SOUND IF ALIGNMENT (See Fig. 10)

1. Test Equipments

4.5 Mc Oscillator

VTVM with DC probe

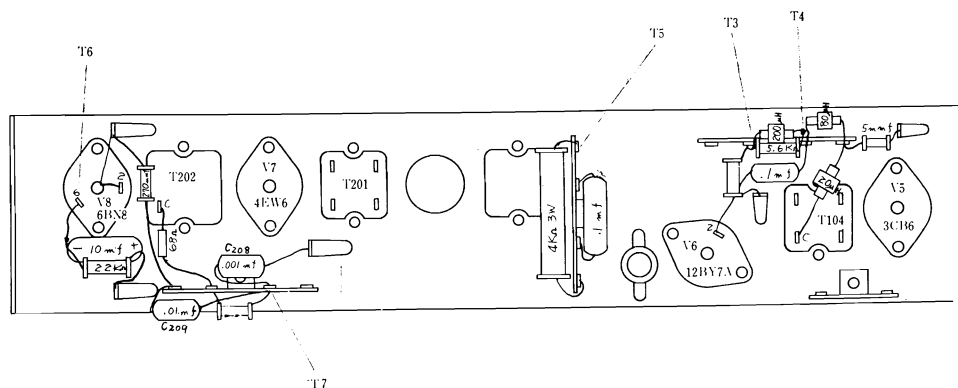

Fig. 10

2. Alignment

Connect VTVM to T-6 and connect oscillator output T-4 of video circuit. Adjust T201 and T202 (outside) so that indication of VTVM will be maximum.

Connect two 100K ohms resistors matched in series between chassis and T-6 (pin 6 of 6BN8).

Connect the ground side of VTVM to the junction of the resistors and the other side of VTVM to the junction of R206 (47KΩ) and C208 (.001mfd.), T-7.

Adjust the inside core of T202 for zero indication. (Oscillator output should be adjusted so that max. DC voltage between T-6 and chassis will indicate 4 volts.)

HORIZONTAL OSCILLATOR ADJUSTMENT

After setting the screw of Horizontal Osc. Transformer T401 at the outside length of about 3/4" and the inside length of 5/8", adjust H. HOLD control until picture is pulled into sync.

Connect the low capacity probe of oscilloscope to T8. The sine wave adjustment core (the inside of T401) should be adjusted so that the pattern on oscilloscope becomes as shown in Fig. 12. During this adjustment, the picture must be kept in sync. by reajusting the H. HOLD control if necessary.

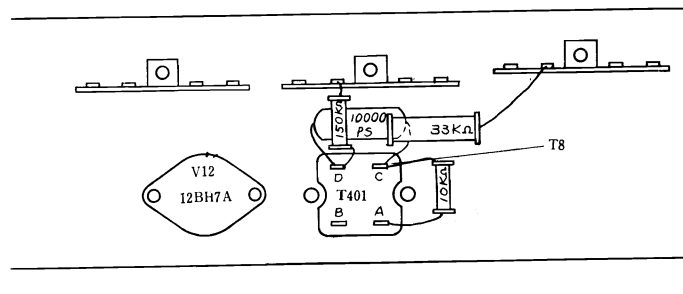

HORIZONTAL CIRCUIT TEST POINT

Fig. 11

DELMONICO Models TVM-11, TVM-33, Service Data, Continued

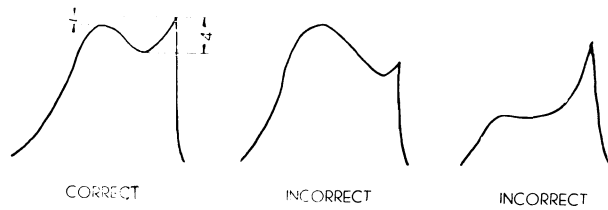

Fig. 12 HORIZONTAL WAVE FORM

Turn H. HOLD control to extreme clockwise position.

The picture should be out of sync. with bars slanting downwards to the right. Adjust the Hor. Freq. adjustment core (the outside of T401) so that about 5 diagonal black bars are obtained. With higher frequencies the circuit may cause double triggering. The H. HOLD control can be rotated to the extreme clockwise or counter-clockwise position.

HEIGHT AND VERTICAL LINEARITY ADJUSTMENTS

Adjust HEIGHT control to align the lower section of raster, and the V. LIN. to the upper section.

For the adjustment of either control will be required to readjust other controls at the same time. During this adjustment, the picture must be kept in sync. by adjusting the V. HOLD control if necessary.

FOCUS ADJUSTMENT

The focus may be varied in steps by the position of the plug P5 in the Focus Adjustment Board.

These are illustrated in Fig. 13. About 270, 140 or zero volts can be selected.

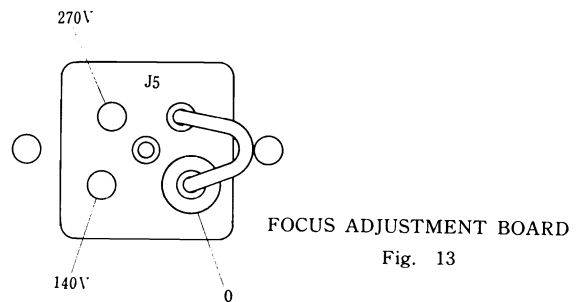
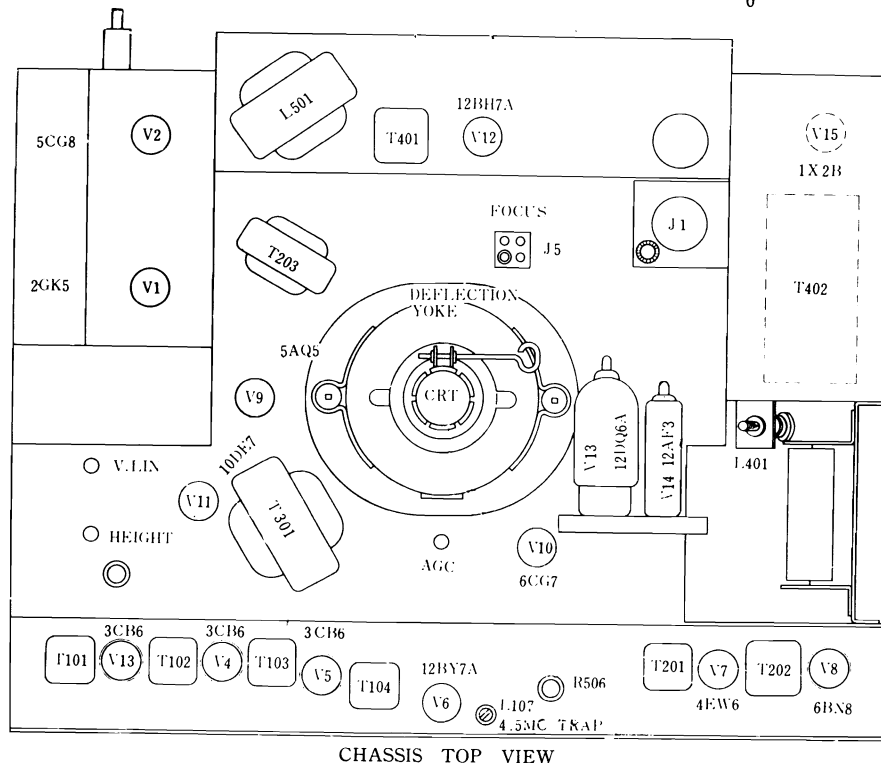

Fig. 13



CHASSIS TOP VIEW

Emerson

Models 11P01 and 11P02, use Chassis 120746, material on the next six pages. Model 11P03, uses Chassis 120788B, is very similar but utilizes type 6LX8 tube as sync separator and keyed AGC instead of type 5HA7, as shown. DuMont Model 41P01 also uses Chassis 120746.

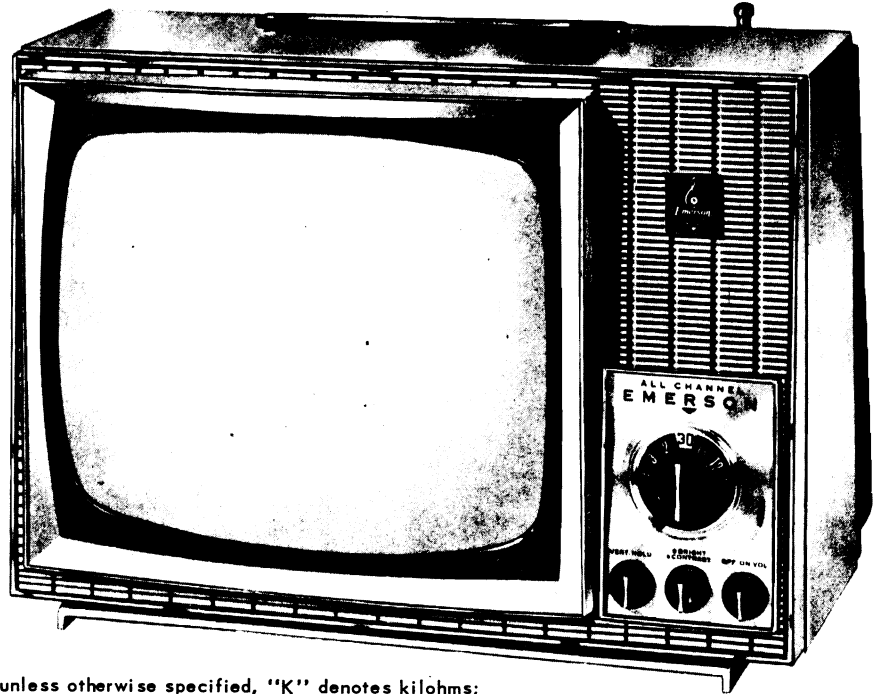

RESISTANCE READINGS

NOTES: All resistance readings are in ohms, unless otherwise specified, "K" denotes kilohms; "M" denotes megohms. "N.C." denotes no connection to terminal indicated. *Indicates measurements taken with common lead of meter connected to junction of L-15 and C-60B (B + 140V point).

| SYMBOL NO. | TUBE TYPE | PIN 1 | PIN 2 | PIN 3 | PIN 4 | PIN 5 | PIN 6 | PIN 7 | PIN 8 | PIN 9 | PIN 10 | PIN 11 | PIN 12 |
|------------|--------------|--------------|--------------------|-------------|------------|--------------------|-------|--------------|-------|-------|------------|--------|--------|
| V-1 | 6GH8 or 6LN8 | *5K | 390K | *0 | (FILAMENT) | | *22K | 2.2K | 0 | 100K | -- | -- | -- |
| V-2 | 4DT6A | 14 | 390 | (FILAMENT) | | 1.2M | *3.3K | 610K | -- | -- | -- | -- | -- |
| V-3 | 17C5/17CU5 | 180 | 100 Ω to 1M | (FILAMENT) | | 100 Ω to 1M | *540 | *700 | -- | -- | -- | -- | -- |
| V-4 | 4EH8 | 142 | 100K | 142 | (FILAMENT) | | 0 | *470 | *470 | 0 | -- | -- | -- |
| V-5 | 4EJ7 | 100 | 0 | 100 | (FILAMENT) | | 0 | *220 | *220 | 0 | -- | -- | -- |
| V-6 | 8AW8A | 0 | 500K to 2M | 5M to 6.2 M | (FILAMENT) | | 15 | 150 | *2.1K | *4K | -- | --- | -- |
| V-7 | C.R.T | (FIL) | 4.1K | 250K | 0 | -- | -- | 100K to 200K | (FIL) | -- | -- | -- | -- |
| V-8 | 5HA7 or 5HC7 | (FIL) | 200K | 5K to 34K | 0 | N.C. | N.C. | N.C. | 0 | 29M | 27K | 20K | (FIL) |
| V-9 | 33GY7 | (FIL) | *1.5 | N.C. | 600K | 600K | N.C. | (FIL) | 0 | 580K | 580K | *1.8K | (FIL) |
| V-10 | 1X2B | INF | INF | -- | INF | INF | INF | -- | INF | INF | (CAP) 580K | -- | -- |
| V-11 | 10CW5 | 2.6M to 3.3M | | 47 | (FILAMENT) | | -- | * 225 | * 225 | * 0 | -- | -- | -- |

VOLUME TV-24, ADDITIONAL 1965 TELEVISION SERVICING INFORMATION

EMERSON Chassis 120746 Schematic Diagram

CONDITIONS FOR CHASSIS READINGS

VOLTAGES AND WAVESHAPES were taken under actual operating conditions, with normal picture and sound being received. AGC voltage developed on the I-F AGC line (test point C) was minus nine volts. Input voltage to chassis under test was 120 volts, 60-cycle AC. Frequencies indicated for the waveshapes shown are approximate sweep settings for the oscilloscope being used (one-half actual frequency of signal being measured).

RESISTANCE MEASUREMENTS were taken with no power. Where readings are affected by control settings, both maximum and minimum values are shown.

ALL MEASUREMENTS were taken between points indicated and chassis ground (unless otherwise noted), using an RCA VoltOhmyst or equivalent VTVM. A low-capacity probe was used for all waveshapes shown in the schematic diagram. All readings obtained may vary $\pm 10\%$ due to normal component tolerances and strength of input signal to chassis under test.

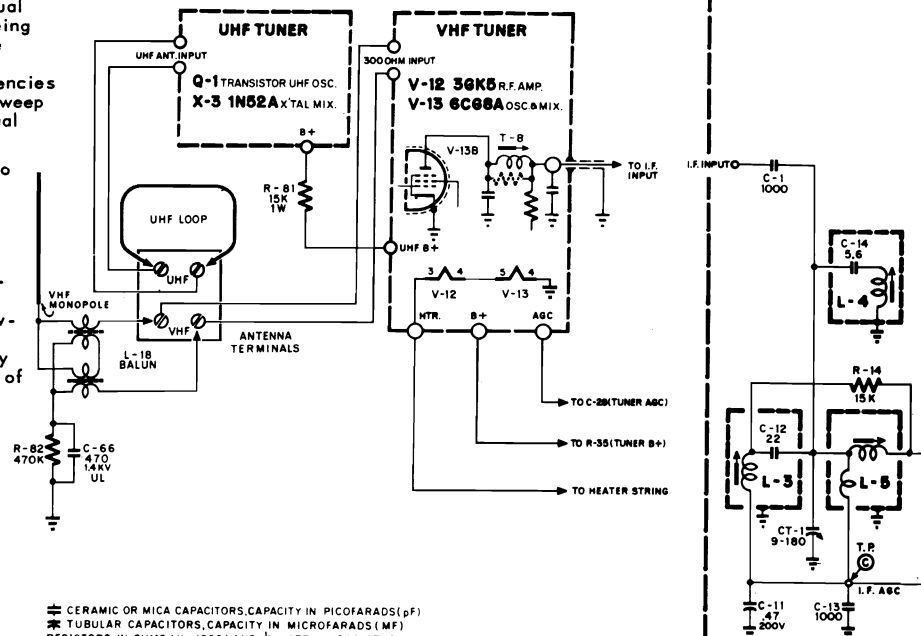

CERAMIC OR MICA CAPACITORS, CAPACITY IN PICO FARADS (PF)

 * TUBULAR CAPACITORS, CAPACITY IN MICROFARADS (MF)

 RESISTORS IN OHMS ($\times 1000$) AND $\frac{1}{2}$ WATT UNLESS OTHERWISE SPECIFIED

 ALL CERAMICS AND MICAS 500V, ALL TUBULARS 400V UNLESS NOTED

 T INDICATES TOP CORE B INDICATES BOTTOM CORE IN DOUBLE TUNED TRANSFORMERS

 ARROWS AT CONTROLS INDICATE CLOCKWISE ROTATION

 REFER TO PRODUCTION CHANGES ON BACK PAGE.

PRODUCTION CHANGES

Each of the following production changes apply to chassis 120746-B only when stamped with the corresponding coded triangle. If, however, this chassis is stamped with any higher letter-code all previous production changes also apply.

- A** 1) To eliminate the possibility of horizontal shading in the picture, a capacitor of .001 mf (pt. no. 928933) was wired across R-34 (from orange wire of CRT to ground).
- B** 1) To compensate for the possibility of vertical size variations with temperature change, a capacitor of 4700 pf (pt. no. 929042X) was added across C-50.
- 2) To ensure stable operation, a 5 ohm resistor, with a rating of 7 watts, (pt. no. 394216) was connected from the junction of R-76 and R-77 to the cold side of the ON-OFF switch (SW-1), eliminating the previous lead and placing this resistor in series with the switch.
- C** 3) To improve vertical tracking from low to high line, R-71 was changed from a resistor of 22 ohms $\frac{1}{2}$ watt $\pm 10\%$ to one of 47 ohms (pt. no. 340172).

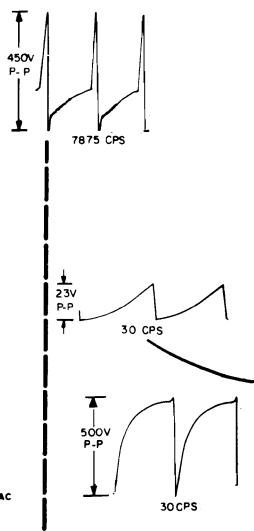
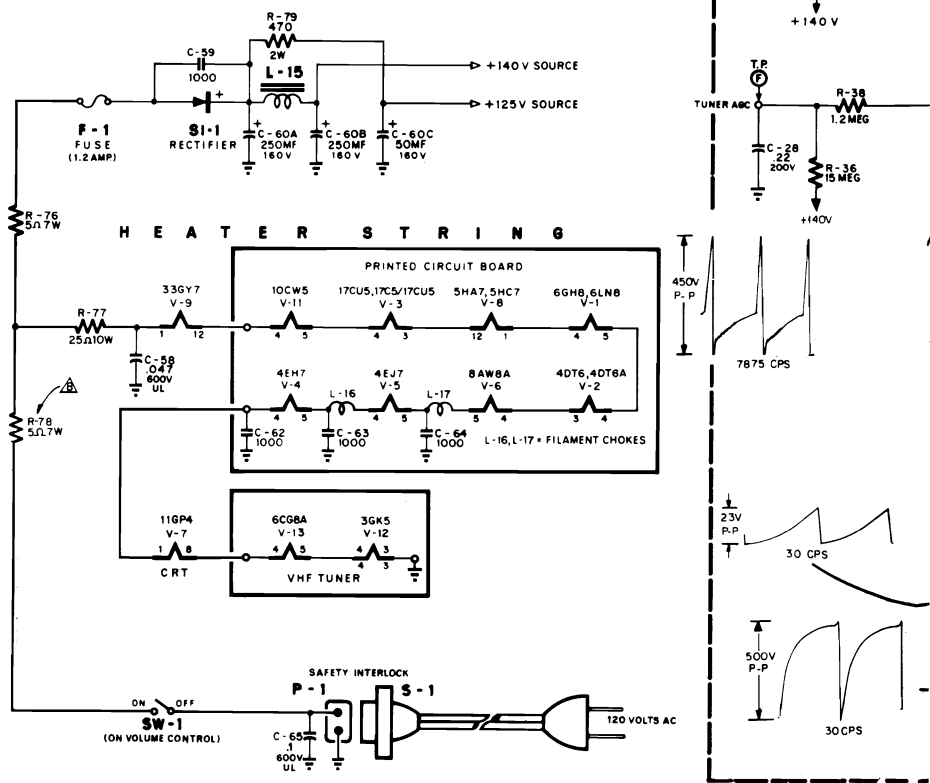

VOLUME TV-24, ADDITIONAL 1965 TELEVISION SERVICING INFORMATION

PRINTED CIRCUIT BOARD

T-2 EMERSON

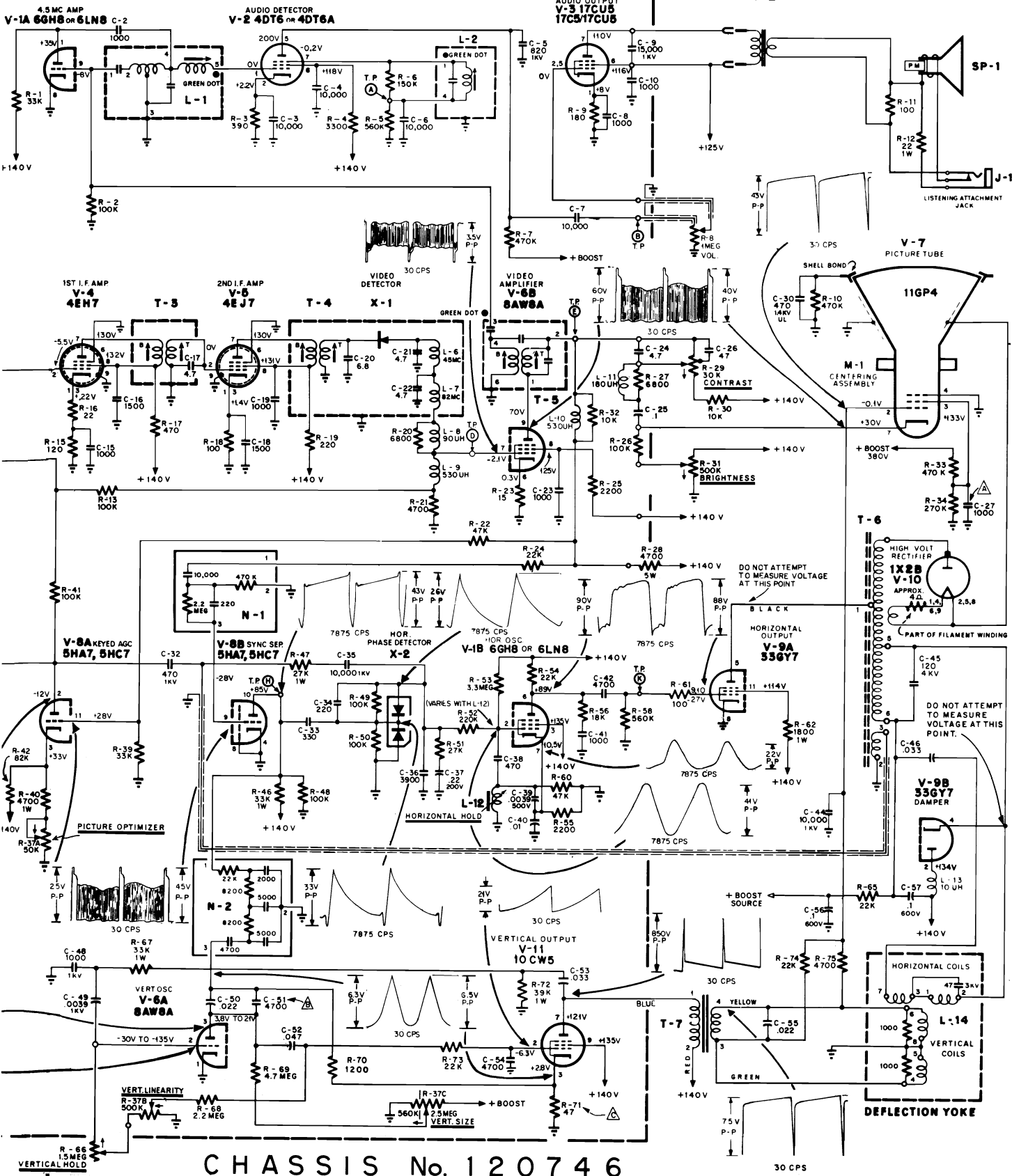

CHASSIS No. 120746

EMERSON Chassis 120746 Alignment Information, Continued

ALIGNMENT INFORMATION

ADJUSTMENT PROCEDURE - I-F STAGES, TRAPS AND TUNER OUTPUT COIL

1. Connect an oscilloscope (through a 10k isolation resistor) to pin 7 of V-6B (grid of video amplifier). Scope should be adjusted so that 2 inches of vertical deflection represents approximately 2 volts P-P output.
2. Connect -4.5 volts bias to the I-F AGC test point (Test point "C"), the junction of C-11 and C-13.
3. Connect a terminated sweep generator, adjusted to sweep between 40 and 50 mc, to pin 2 of V-5 (grid of second I-F amplifier) through a 1,000 pf isolation capacitor.
Note: If sweep generator does not have internal markers, a separate marker should be loosely coupled to the output of the sweep generator.
4. Adjust T-4 top and bottom simultaneously for maximum gain and symmetry about the 44.0 mc marker as shown in Fig. 1. (Use core positions nearest outside ends of coil.) With input signal maintained to produce 2 volts P-P output during final adjustment, bandwidth markers should fall between the tolerances indicated.
5. Disconnect generator output leads from grid of second I-F amplifier and connect them to pin 2 of V-4 (grid of first I-F amplifier).
6. Adjust T-3 top and bottom simultaneously for over-coupled response as shown in Fig. 2. (Use core positions nearest outside ends of coil.) With input signal maintained to produce 2 volts P-P output during final adjustment, bandwidth markers should fall between the tolerances indicated.
Note: The correct overcoupled response is indicated when slight rocking of T-3 core settings do not change the amplitude of the 44.0 mc marker, but cause the response to rock or slide about this marker.
7. Reduce the amount of bias applied to the I-F AGC test point (test point "C") to -1.5 volts.
8. Disconnect generator output leads from grid of the first I-F amplifier and couple them to the mixer tube (V-13) of the VHF tuner, using the signal injection shim described below. If this is impractical, connect the generator output leads to the I-F mixer point on the tuner, using the coupling network shown in Fig. 3.
Note: A signal injection shim may be easily constructed by pasting a thin piece of metal foil (approx. 1/2" x 2") on a slightly larger piece of heavy paper. Insert this shim between the mixer tube and its shield in such a manner that the foil side faces the tube, and rotate for maximum signal coupling.
9. Open trimmer CT-1 three turns from its fully closed position and adjust output of generator to produce approximately 2 volts P-P indication on 'scope.
10. Adjust the tuner output coil (T-8) for maximum gain and symmetry about the 44.0 mc marker.
11. Adjust the 41.25 mc trap (L-4) and the 47.25 mc trap (L-3) for minimum output at these frequencies (as indicated by their respective markers on the 'scope), increasing generator output as required to insure maximum effectiveness of the trap settings.
12. Reduce output of generator to produce approximately 2 volts P-P deflection on 'scope and re-adjust the tuner output coil (T-8) for maximum gain and bandwidth about the 44.0 mc marker.
13. Disconnect oscilloscope from pin 7 of V-6B and connect to pin 7 of V-4 (plate of first I-F amplifier), using a low impedance crystal detector probe as shown in Fig. 8. 'Scope should be calibrated so that 2 inches of vertical deflection now represents approximately 0.2 volts P-P.
14. Reduce output of generator until a usable display is produced on the oscilloscope and again adjust the tuner output coil (T-8), this time tuning for maximum gain midway between the peaks of the band-pass as indicated in Fig. 4. The 44.0 mc marker should fall between the tolerances indicated.
15. Maintain generator output to produce approximately 0.2 volts P-P indication on the oscilloscope (as above) and adjust the grid coil (L-5) to center the 44.0 mc marker on the peak of the response as indicated in Fig. 5, disregarding the tilt of the overall waveshape.
16. Adjust the input trimmer (CT-1) to position the 42.25 and 45.75 mc markers at equal amplitudes and center the 44.0 mc marker with the tuner output coil (T-8), if necessary.
17. With generator output increased to maximum, check the position of the 41.25 mc and 47.25 mc traps (L-4 and L-3), and re-adjust if necessary.
18. Re-adjust generator output to produce a 0.2 volt P-P indication on the 'scope and observe the response. The curve obtained should conform to Fig. 6.
19. Disconnect the crystal detector probe and connect the oscilloscope to pin 7 of V-6B (grid of the video amplifier) directly through a 10K isolation resistor.
20. Increase bias voltage to -4.5 volts and adjust the oscilloscope so that 2 inches of vertical deflection is equivalent to approximately 2 volts P-P output. Adjust output of signal generator until a 2 volt P-P indication is obtained on the 'scope. Response curve and marker positions should conform to Fig. 7.
21. Remove AGC bias from test point "C". Output signal as indicated on the 'scope should increase, and noise signal on baseline should have an amplitude of at least 1/8 inch.
CAUTION - No attempt should be made to improve a response curve which conforms to that shown in Fig. 7. Minor deviations may be corrected by slight touch-up of specific coils to make response conform to Fig. 7, as indicated below:
a) To position the 45.75 mc marker adjust T-3, bottom slug.
b) To position the 42.25 mc marker adjust T-4, bottom slug.
c) To correct tilt, adjust T-8, the tuner output coil.

VOLUME TV-24, ADDITIONAL 1965 TELEVISION SERVICING INFORMATION

EMERSON Chassis 120746 Alignment Information, Continued

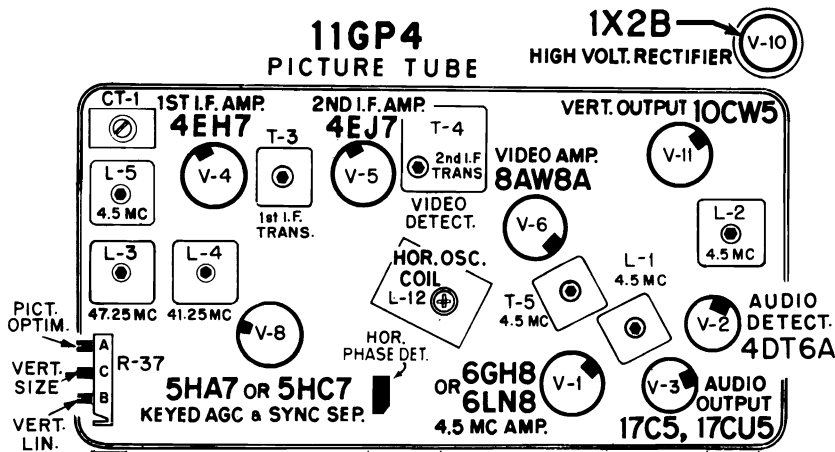
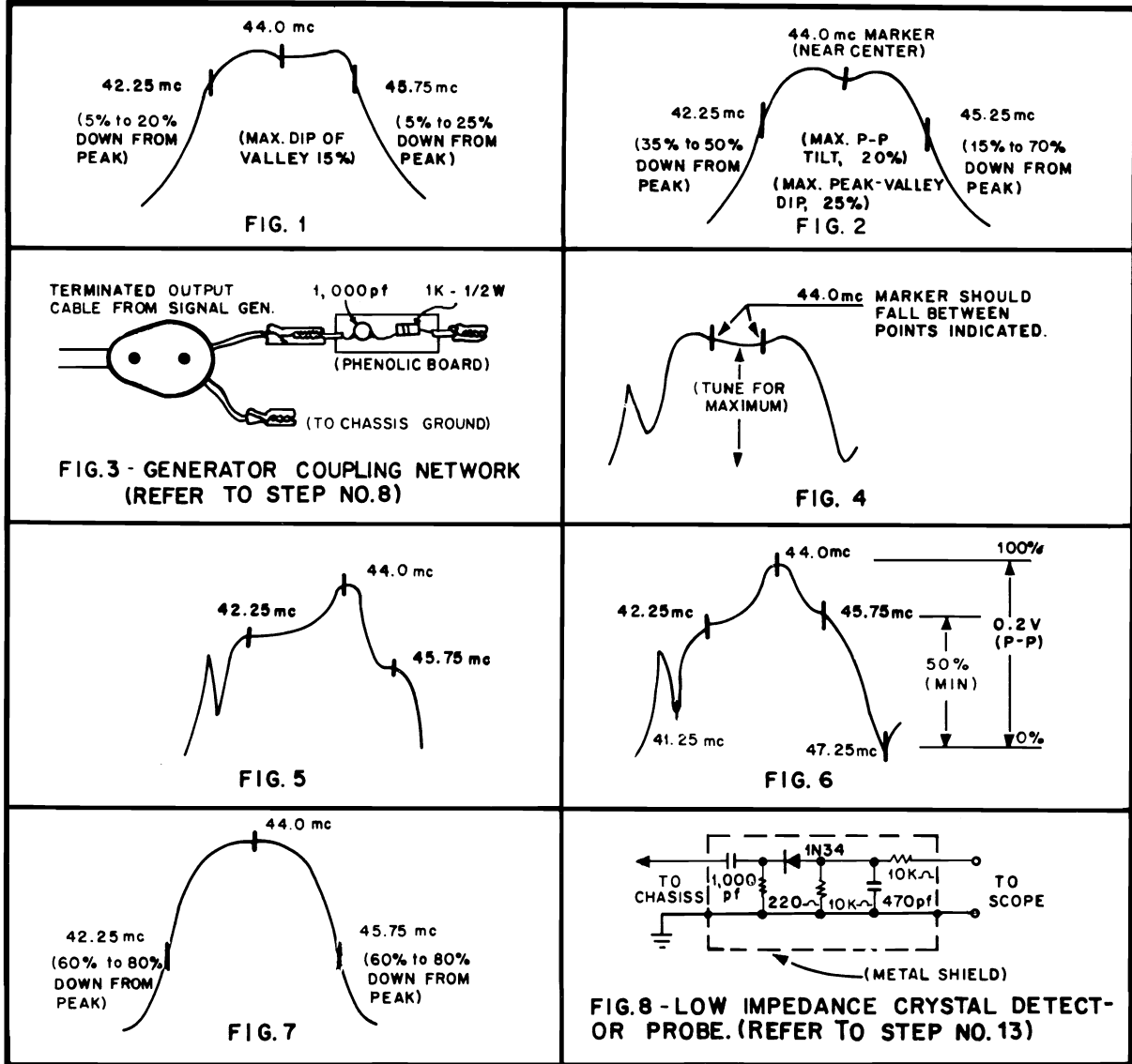

NOTES: (V-9) 33GY7-HORIZ. OUTPUT/DAMPER LOCATED OFF BOARD.

FIG. 9A, B - (A) TUBE LOCATIONS AND ALIGNMENT POINTS

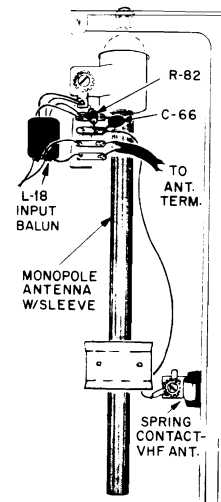

(B) VHF ANTENNA/BALUN ASSEMBLY

EMERSON Chassis 120746 Alignment Information, Continued

ADJUSTMENT PROCEDURE - SOUND TAKE-OFF, SOUND INTERSTAGE, SOUND DETECTOR & 4.5 MC TRAP

1. With antenna connected directly to VHF terminals of receiver, set the channel selector to a strong local station and adjust the fine-tuning control until a 4.5 mc beat is just visible in the picture being viewed.
2. Adjust the 4.5 mc sound trap (T-5, top slug) until the 4.5 mc beat in the picture is either at minimum or is completely eliminated.
3. Adjust the sound quadrature coil (L-2) for loudest sound consistent with minimum buzz, using the second peak from the top of the coil.
4. Using some form of attenuation between the antenna and the VHF input terminals, gradually reduce the level of the input signal until distortion is noticeable in the audio output.
5. Adjust the sound take-off transformer (T-5, bottom slug) and the sound interstage coil (L-1) for loudest and clearest sound.
6. Keep reducing the level of the input signal until sound distortion again occurs, and re-tune T-5 bottom slug and L-1 for loudest and clearest sound. Repeat this procedure until no further improvement can be noted.
7. Re-connect antenna directly to VHF terminals of receiver (attenuator removed) and touch-up quadrature coil (L-2) for minimum buzz in sound.

VHF TUNER 471534

GENERAL DESCRIPTION

VHF Tuner 471534 is a 13 position rotary turret assembly utilizing a type 3GK5 for R-F amplification and a 6CG8A as a combined mixer and local oscillator. This tuner features individually adjustable oscillator circuits for each of the receivable VHF channels, and is equipped with the conventional type of fine tuning. The 13th (channel 1) position converts this tuner to an I-F amplifier for use in conjunction with a separate UHF tuner assembly.

LOCAL OSCILLATOR ADJUSTMENTS

Adjustment of the local oscillator screws in tuner 471534 can be accomplished without removing the chassis from the cabinet. Removing the channel selector and fine-tuning knobs will expose access holes in the tuner mounting bracket, suitable for passage of an alignment tool. The individual oscillator adjustment screws, which may be adjusted in any order desired, must be tuned with an extremely thin alignment tool designed for this purpose, since the use of an alignment tool with too large a diameter will damage the coil forms and render them useless.

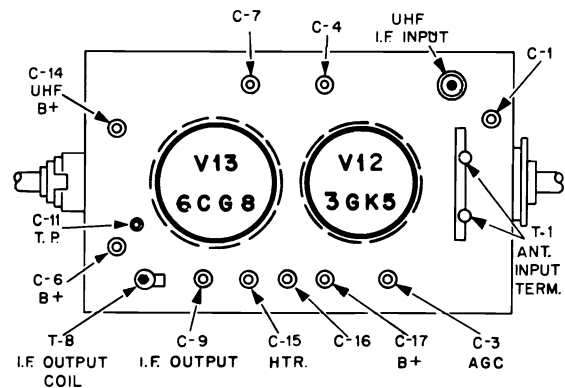

FIG. 11 - VHF TUNER 471534

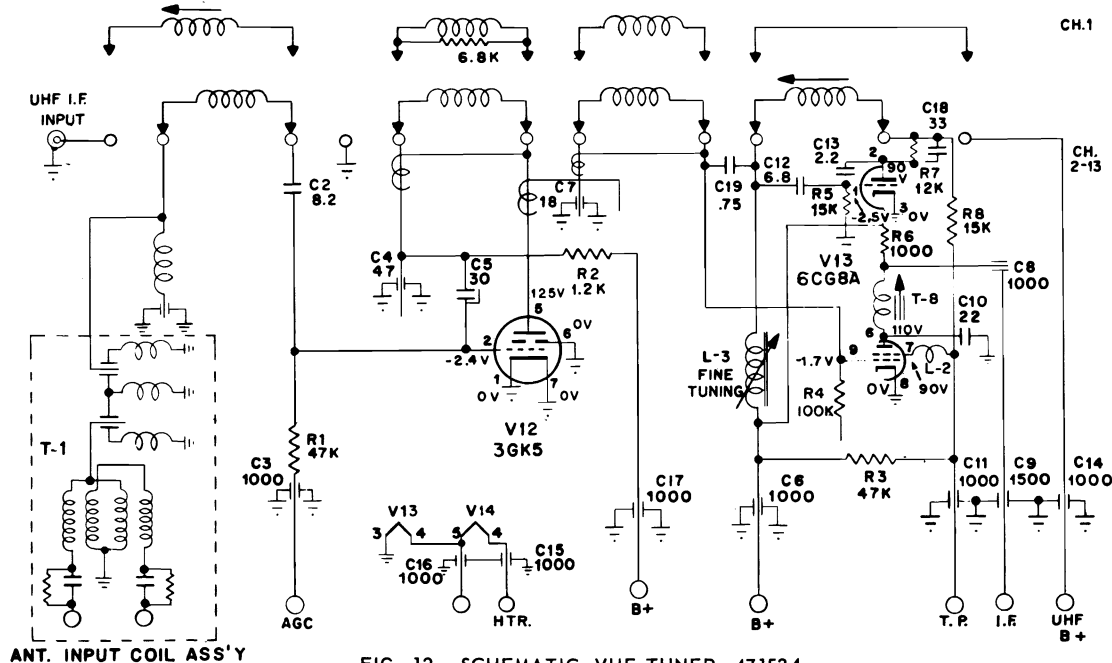

FIG. 12 - SCHEMATIC, VHF TUNER 471534

GENERAL ELECTRIC

BY CHASSIS

MODELS
 SAM334YMD
 SAM334YMP
 SAM334YWD
 SAM335YMD
 SAM335YMP
 SAM335YWD

MODELS

SAM332YMD
 SAM332YMP
 SAM332YOA
 SAM332YWD
 SAM333YMD
 SAM333YMP
 SAM333YOA
 SAM333YWD

BY CHASSIS

MODELS
 SAM360YMD
 SAM360YOA
 SAM360YWD
 SAM361YMD
 SAM361YOA
 SAM361YWD

BY CHASSIS

MODELS
 SAM362YMD
 SAM362YMP
 SAM362YWD
 SAM363YMD
 SAM363YMP
 SAM363YWD

DISASSEMBLY PROCEDURE

CABINET BACK: Disconnect any external antenna wires. Then remove the screws securing the back to the cabinet and carefully detach the back.

CHASSIS: First remove the back as described. Remove two chassis retaining 1/4-inch hex head screws from the top back corners of the chassis and slide the chassis back away from the two front chassis retaining clips. A service support bar is included on the back apron of the chassis for servicing without completely removing the chassis from the cabinet. The chassis may be tilted up at the back and with the service bar fastened to the top back of the receiver cabinet, the chassis is held in a tilted position for servicing ease. To completely remove the chassis, remove the control knobs, then the 4 retaining screws holding the control assembly to the escutcheon. Discharge the picture tube anode with a chassis grounded shorting wire and remove the anode lead. Take off the picture tube socket; yoke; disconnect the loudspeaker; and remove two 1/4-inch hex head screws retaining the antenna balun leads to the chassis. The chassis and control assembly may now be removed from the cabinet.

PICTURE TUBE: Remove the cabinet back and chassis as described; then place cabinet face down on a soft cloth-covered surface. A wood block, two inches thick, is placed under the cloth where the top middle of the cabinet front will rest. Remove one 5/16-inch hex head screw from the tube sling. The picture tube is now removed from the cabinet.

ELECTRICAL ADJUSTMENTS

HEIGHT AND VERTICAL LINEARITY: Adjust R207 and R214 simultaneously for proper vertical size and linearity. Picture should extend 1/8-inch beyond top and bottom edges of mask.

HORIZONTAL HOLD:

1. Remove the cabinet back.
2. Tune the receiver to a weak signal and adjust the controls for normal operation.
3. Using a jumper wire, short Test Point VI to chassis.
4. Connect a 1000 ohm resistor from Test Point VIII to Test Point IX (in parallel with L251).
5. Adjust HORIZONTAL HOLD potentiometer, R260, until picture just "floats" back and forth across the screen. Leave R260 set in this position.
6. Remove the 1000 ohm resistor from Test Point VIII and Test Point IX. Adjust L251 (stabilizer coil) so that the picture again just "floats" across the screen, turning the core toward the printed board. Leave L251 set in this position.
7. Remove the chassis jumper from Test Point VI. Repeat adjustments if the picture does not "lock".

PICTURE TUBE ADJUSTMENTS

PICTURE TILT: To correct picture tilt, loosen the YOKE CLAMP with long nose pliers by sliding the eye of the spring over the bend in the clamp. Adjust the yoke to correct picture tilt. Secure the yoke with the pliers by squeezing between the eye of the spring and a point below the bend in the clamp until the spring slips over the bend.

PICTURE CENTERING: Rotate the two centering rings located at the rear of the yoke assembly until picture is properly centered.

FOCUS: Three potentials are available in the receiver for focus adjustment—ground, +170 volts and B+ boost. Focus was correctly adjusted at the factory. If it becomes necessary to adjust focus, connect the orange lead from R187 and pin 4 of the picture tube base to the potential which produces best focus. Refer to the sweep circuit board diagram for the connection points.

WIDTH CONTROL: Adjust this control for largest picture necessary to fill mask.

AGC CONTROL:

Field Adjustment: Tune in the strongest available signal and adjust R186 to the point where overloading is indicated by "tearing" of the picture. Then back off the AGC control to just beyond the point where the overload condition disappears. Before adjusting the AGC control, set the contrast control to the clockwise extreme. The ABC Defeat switch should be placed in the OFF position and left there during alignment.

Instrument Adjustment:

1. Tune in a broadcast signal, preferably a monoscope signal that is monitored to assure that the percentage of sync does not exceed 25 percent.
2. Connect an oscilloscope to Test Point IV. Synchronize the scope at a vertical rate and observe at least two vertical sync pulses.
3. Adjust the fine tuning for smear and the AGC control for the point where the sync pulses begin to compress. Then back off the AGC control slightly from this point.

(Material continued on pages 36 through 40)

VOLUME TV-24, ADDITIONAL 1965 TELEVISION SERVICING INFORMATION

GENERAL ELECTRIC Chassis BY Alignment Information

VIDEO I-F SYSTEM

GENERAL: Allow receiver and test equipment at least 20 minutes warm-up.

1. Turn volume control to minimum and contrast control fully clockwise. Set channel selector to Channel 9 and fine tuning fully counterclockwise.
2. Short antenna terminals together.
3. Connect oscilloscope to Test Point III through 22,000 ohm resistor not more than 2.5 inches away from Test Point III. Connect -4.5V bias between Test Point II and chassis.
4. Inject signals from a properly terminated AM signal generator or sweep generator, through the I-F INJECTION NETWORK shown, to the I-F injection point.
5. Align the receiver to produce the response curve illustrated.
6. All cores are positioned away from printed board.

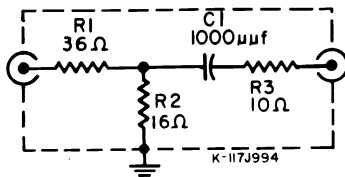

I-F INJECTION NETWORK

AM PRE-PEAKING FREQUENCIES

| | |
|------------|-----------------|
| L150 | Min. at 47.25MC |
| L135 | Max. at 45.75MC |
| L151 | Max. at 42.50MC |
| L153, L154 | Max. at 44.15MC |
| T151 | Max. at 43.00MC |
| T152 | Max. at 45.20MC |

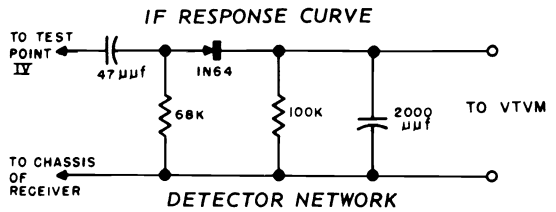
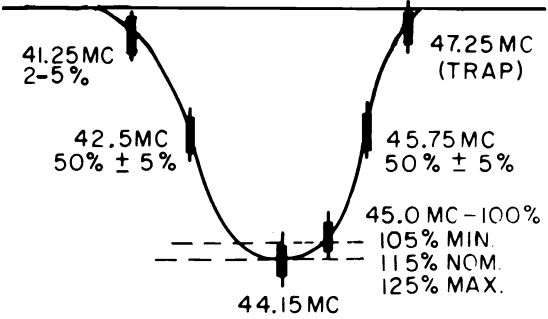

DETECTOR NETWORK

VIDEO I-F ALIGNMENT CHART

| STEP | SIGNAL FREQUENCY | ADJUST | REMARKS |
|------|--|---|--|
| 1. | 47.25 MC AM | Adjust L150 for minimum scope deflection. | Use maximum scope sensitivity and smallest possible signal for the 47.25 MC AM adjustments. |
| 2. | 44.15 MC AM | Adjust first L154, then L153 for maximum scope deflection. | Do not retouch these adjustments. (L153 core must be flush with top of coil when L154 is peaked.) |
| 3. | 38-48 MC sweep generator, with scope calibrated 3 volts peak to peak for 2 inch deflection; markers at 41.25, 42.5, 44.15, 45 & 45.75 MC | L135 (converter plate) for maximum deflection of the 45.75 MC marker. | |
| 4. | SAME | L151 (1st I-F grid) for maximum deflection of the 42.5 MC marker and proper nose shaping. | Symmetry of the nose is important. No portion of the nose should be out of symmetry by more than 3%. |
| 5. | SAME | T152 (2nd I-F Plate) to place 45.75 MC marker properly on the curve. | Repeat 4, 5 and 6 if necessary. |
| 6. | SAME | T151 (1st I-F Plate) to place 42.5 MC marker properly on the curve. | |
| 7. | SAME | L151 if necessary to shape the nose. | |

4.5 MC TRAP ALIGNMENT

1. Connect a -7.5 bias to Test Point II, with the positive bias lead grounded to chassis.
 2. Turn contrast control to maximum, volume to minimum.
 3. Connect the detector network shown on this page to Test Point IV and feed its output to an AC VTVM.
 4. Apply a 4.5 MC AM signal through a 5 µf capacitor at Test Point III.
 5. Adjust the top slug of T153 for minimum reading on the VTVM. Two core positions will give an apparent minimum indication; the correct one is nearer the top end of the coil form.
- NOTE:** Retouching of the trap adjustment may be necessary after alignment of the audio takeoff.

AUDIO ALIGNMENT WITH ON-THE-AIR SIGNALS

1. Tune in a strong local signal and set receiver volume to a low audible level.
2. Adjust L301 for maximum undistorted, buzz-free audio output. Start with the core at the outermost position away from the printed board and tune for the second "peak" encountered on the way into the coil form.
3. Connect a variable bias supply (3 to 15V) to the AGC test point with the positive lead to the chassis. Adjust bias until audio signal distorts on peaks slightly, then adjust core of T301 to curb distortion. Repeat this procedure several times at increased bias levels until maximum clarity of audio is obtained.
4. Adjust the bottom core of T153, repeating the bias advances in step 3, to achieve the optimum setting for noise-free performance at low signal levels.

ADDITIONAL

1965 TELEVISION SERVICING INFORMATION

GENERAL ELECTRIC BY Chassis

Tube and Adjustment Location Diagram.

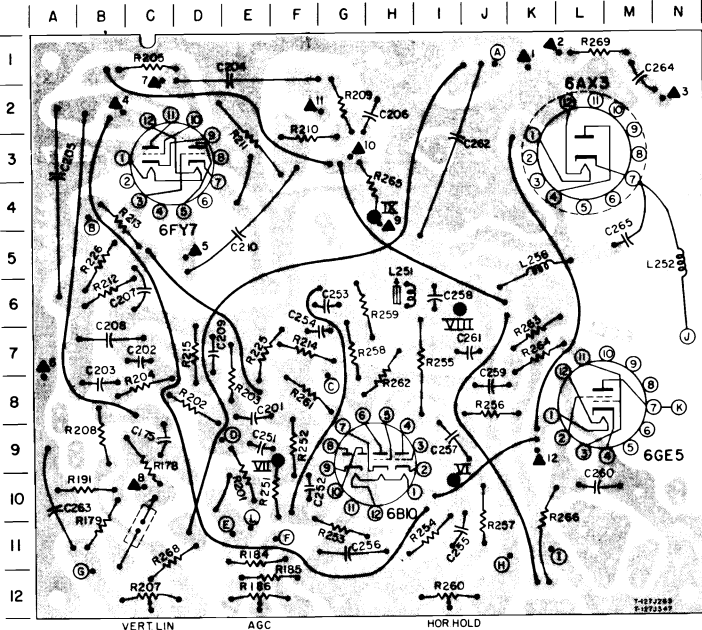
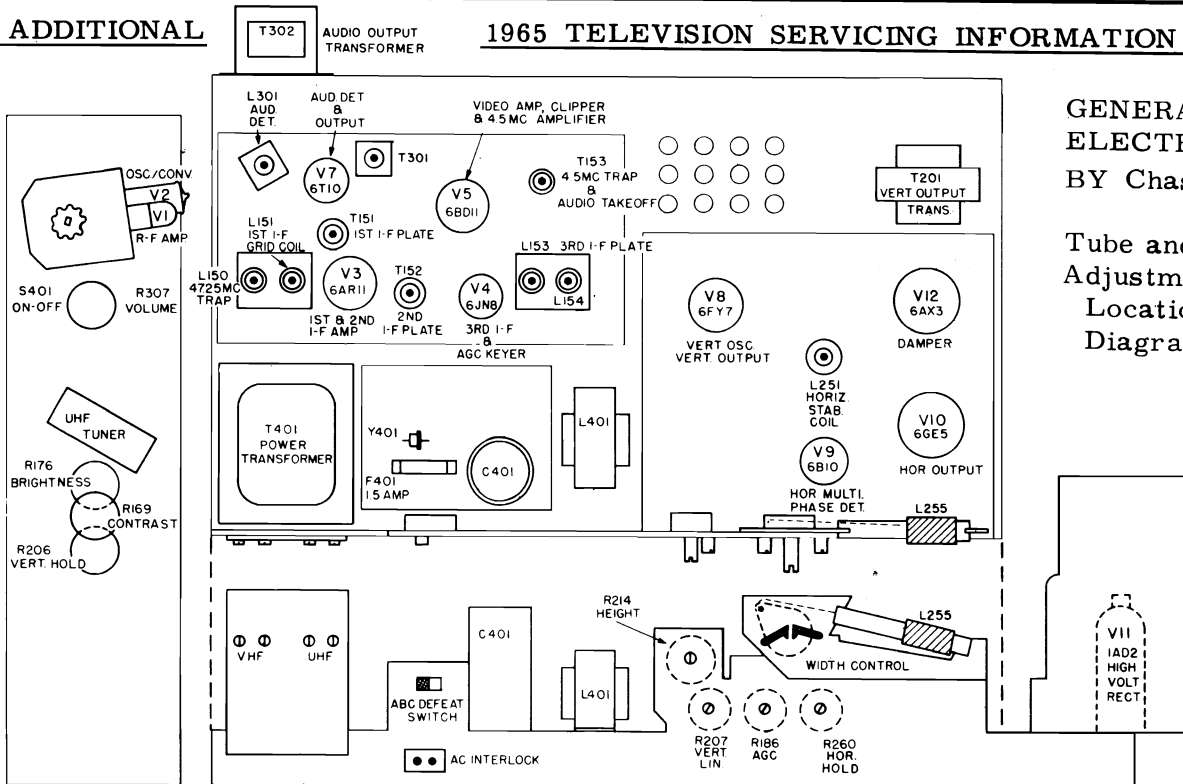

- CIRCLED (A) LETTERS**
 REPRESENT INTERCONNECTING WIRES SOLDERED INTO BOARD
 (A) TO PIN 1 OF T251
 (B) TO R214 HEIGHT CONTROL ARM
 (C) TO ▲18 ON I-F BOARD
 (D) TO ▲6 ON I-F BOARD
 (E) TO ▲8 ON POWER SUPPLY BD
 (F) TO ▲15 ON I-F BOARD
 (G) TO ▲11 ON I-F BOARD
 (H) TO ▲4 ON POWER SUPPLY BD
 (I) TO L255
 (J) TO PIN 7 OF T251
 (L) TO ▲10

- TRIANGLE (▲) NUMBERS**
 REPRESENT WIRE WRAP TERMINALS ON COMPONENT BOARD FOR CONNECTION OF WIRES TO POINTS INDICATED
 ▲1. GROUND FOR SHIELD OF CABLE FOR ▲2
 ▲2. TO ▲14 ON I-F BOARD
 ▲3. TO PIN 4 ON T251 & L255
 ▲4. TO (4) ON I-F BOARD
 ▲5. BLUE LEAD OF T201
 ▲6. BLACK LEAD (SHIELD) CRT PIN 3 & R214 HEIGHT CONTROL
 ▲7. TO VERT HOLD CONTROL END
 ▲8. PIN 3 OF CRT
 ▲9. TEST POINT IX
 ▲10. TO (1) YOKE PIN 1 & RED LEAD OF T201
 ▲11. TO YELLOW LEAD OF T201 & YOKE PIN 3
 ▲12. PIN 8 OF PIX TUBE

ROMAN (II) NUMERALS
 INDICATE TEST POINT

SWEEP BOARD COMPONENT LOCATIONS

| RESISTORS & POTENTIOMETERS | | | COILS | CAPACITORS | |
|----------------------------|----------|----------|---------|------------|----------|
| R178-C10 | R209-G2 | R255-I7 | L251-H6 | C175-C9 | C253-G6 |
| R179-B11 | R210-F3 | R256-J9 | L252-N5 | C201-E9 | C254-F7 |
| R184-E11 | R211-E3 | R257-J11 | L253-K5 | C202-C7 | C256-G11 |
| R185-E12 | R212-B6 | R258-G7 | | C203-B8 | C257-I9 |
| R186-E12 | R213-B4 | R260-I12 | | C204-E1 | C258-I6 |
| R191-A10 | R214-F7 | R261-F8 | | C205-A3 | C259-J8 |
| R201-E10 | R215-D7 | R263-K7 | | C206-H2 | C260-L10 |
| R202-D8 | R225-E7 | R264-K7 | | C207-C6 | C261-J7 |
| R203-E8 | R226-B5 | R265-H4 | | C208-B7 | C262-I3 |
| R204-C8 | R251-F10 | R266-K11 | | C209-D7 | C263-A10 |
| R205-C1 | R252-F9 | R268-C11 | | C210-E5 | C264-M1 |
| R207-C12 | R253-G11 | R269-L1 | | C251-E9 | C265-M5 |
| R208-B9 | R254-I11 | | | | |

VOLUME TV-24, ADDITIONAL 1965 TELEVISION SERVICING INFORMATION

GENERAL ELECTRIC Chassis BY Schematic Diagram

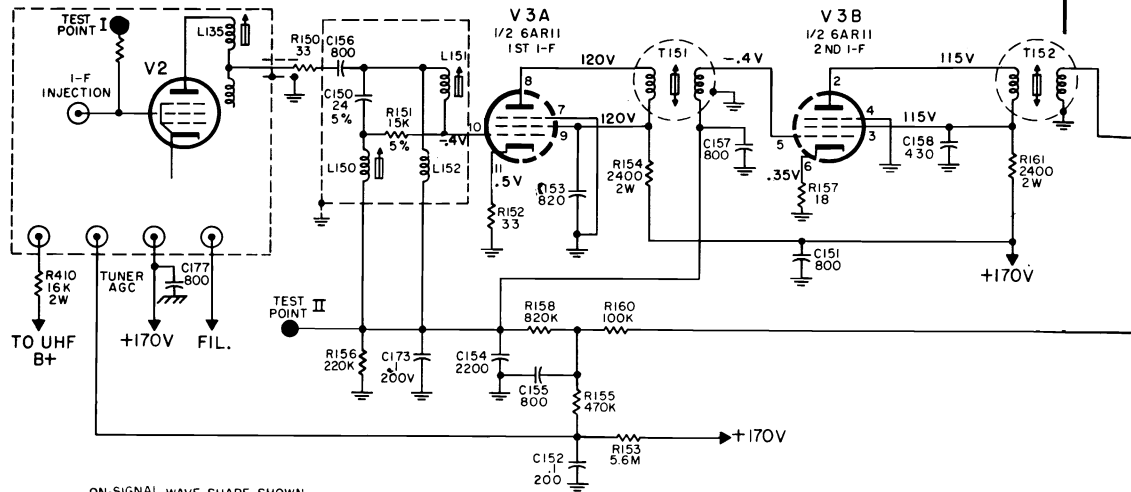

ALL VOLTAGE MEASUREMENTS MADE WITH A VACUUM TUBE VOLTMETER IN RESPECT TO CHASSIS GROUND WITH RECEIVER CONTROLS SET FOR NORMAL OPERATION

WITH LINE VOLTAGE MAINTAINED AT 120 VAC MEASUREMENTS SHOWN MAY DEVIATE $\pm 10\%$

VOLTAGES SHOWN IN BLACK MADE WITH THE SELECTOR KNOB SWITCHED TO A CHANNEL WITH NO SIGNAL AND THE ANTENNA TERMINALS SHORTED & GROUNDED

RESISTANCE MEASUREMENTS MADE WITH COMPONENTS DISCONNECTED

• VARIES WITH CONTROL SETTINGS

* VOLTAGE TAKEN WITH BRIGHTNESS CONTROL AT MAX. COUNTERCLOCKWISE SETTING.

ON-SIGNAL WAVE SHAPE SHOWN TAKEN WITH A NOISE FREE SIGNAL PRODUCING -1.5 TO -3 VOLTS AGC AT VHF TUNER FINE TUNING CONTROL ADJUSTED FOR MAXIMUM AGC.

ALL OTHER CONTROLS ARE ADJUSTED FOR NORMAL OPERATION

** SCOPE SYNCED AT 1/2 VERT. FREQUENCY

*** SCOPE SYNCED AT 1/2 HORIZ. FREQ.

UNLESS OTHERWISE NOTED
K=1000 M=1,000,000
CAPACITORS MORE THAN 1 μ F + pF
CAPACITORS LESS THAN 1 μ F
RESISTORS ARE 1/2 WATT

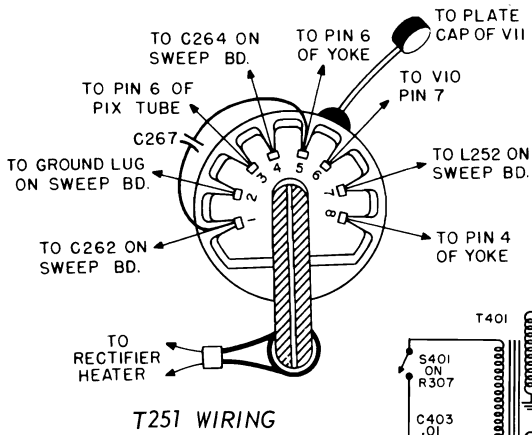
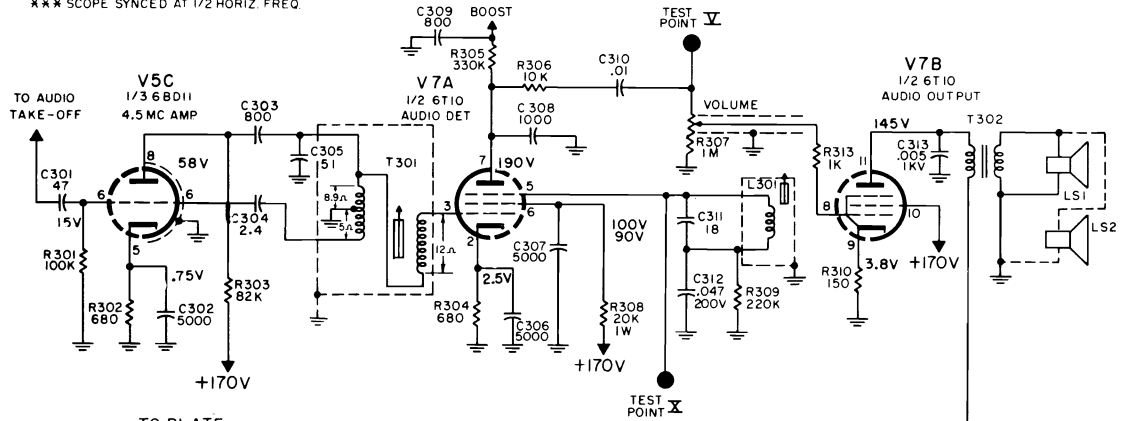

T251 WIRING

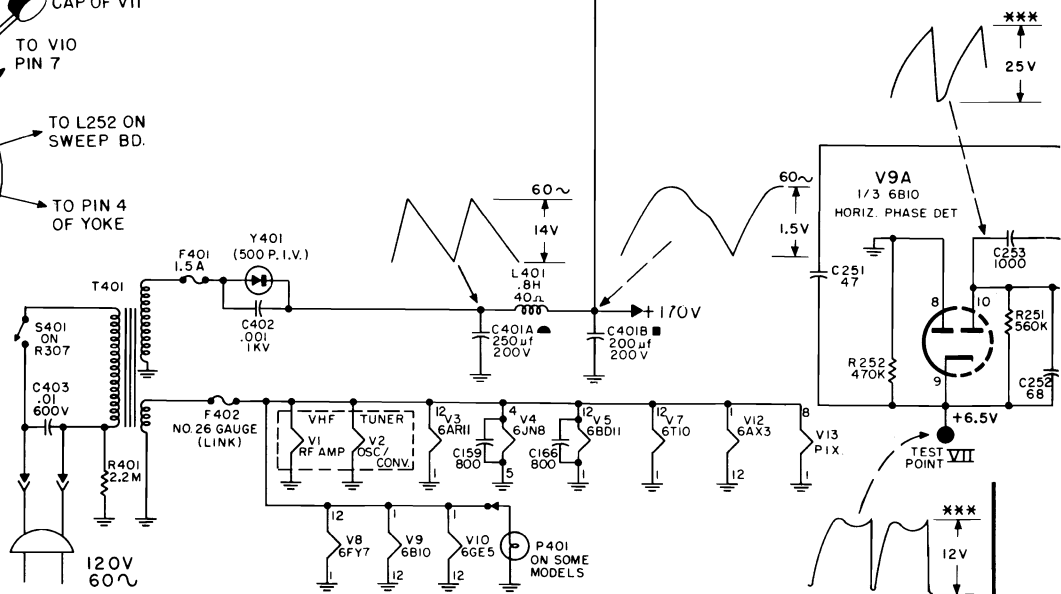

GENERAL ELECTRIC

DB CHASSIS

MODELS
M401BBG
PAM401BWD
M403BEB
M403BVB
M403BWD

MODELS
M413BBG
M413BWD
R413BBG
R413BWD
M415BVB
M415BWD

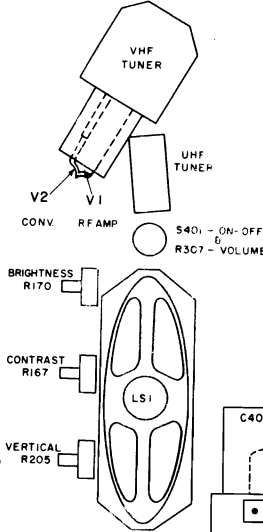
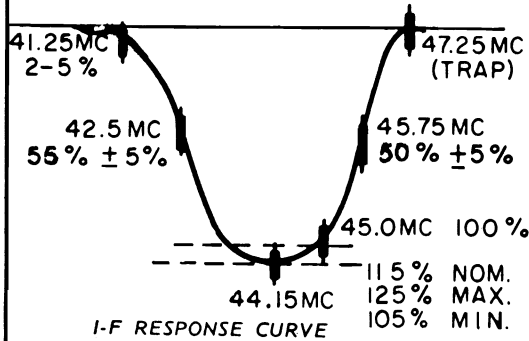

VIDEO I-F SYSTEM

Turn volume control and fine tuning counterclockwise, and contrast control fully clockwise. Set channel selector to Channel 11. Short antenna terminals together.

Connect oscilloscope to Test Point III thru 22,000 ohms resistor not more than 2.5 inches away from Test Point III. Connect a variable bias supply (0-20V) between Test Point II and chassis.

Align the receiver to produce the response curve illustrated.

Position all cores at ends of coils away from circuit board except as noted below.

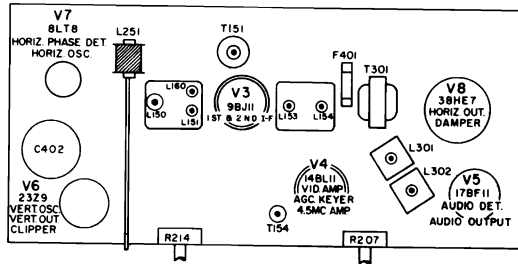
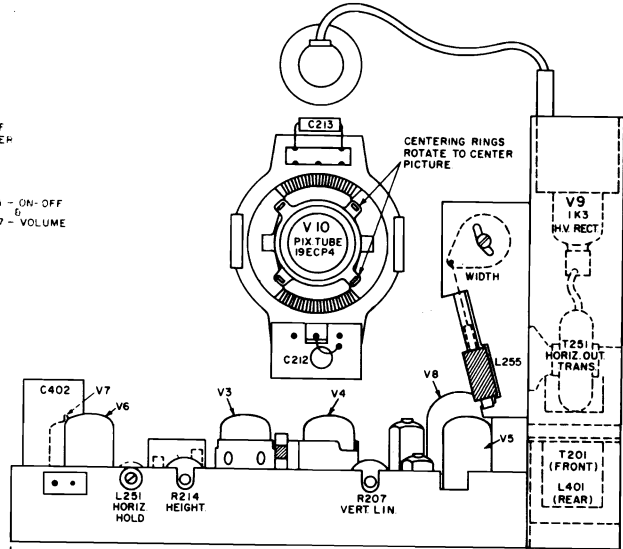

VIDEO I-F ALIGNMENT CHART

| STEP | SIGNAL FREQUENCY | ADJUST | REMARKS |
|------|---|--|--|
| 1 | 47.25 MC AM (Bias 0V) | Adjust L150 for minimum scope deflection | Use maximum scope sensitivity and smallest possible signal for the 47.25 MC AM and 41.25 MC AM adjustments. |
| 2 | 41.25 MC AM (Bias 0V) | Adjust L160 for min. deflection | |
| 3 | 43.15 MC AM (Bias 0V) | Adjust T151 for max. deflection | Position L154 core at end of coil nearer circuit board. Do not retouch these adjustments. |
| 4 | 44.15 MC AM (Bias -10V) | Adjust L154, then L153 for max. | |
| 5 | (Bias -10V) | L135 for max. at 45MC and placement of 45.75 MC marker | |
| 6 | 38-48 MC sweep generator, with scope calibrated 3 volts peak to peak for 2 inch deflection; markers at 41.25, 42.5, 44.15, 45.0 MC & 45.75 MC | T151 for max. at 43.15 MC | Symmetry of the nose is important. No portion of the nose should be out of symmetry by more than 3%. Repeat last four steps if necessary. |
| 7 | | L151 for max. at 42.5 MC and shaping of nose around 44.15 MC | |
| 8 | | L152 if 42.5 MC marker is above 55% on curve. | |

AUDIO ALIGNMENT WITH ON-THE-AIR SIGNALS

1. Tune in a strong local signal and set receiver volume to a low audible level.
2. Adjust L302 for maximum undistorted, buzz-free audio output. Start with the core at the outermost position away from the printed board and tune for the second "peak" encountered on the way into the coil form.
3. Connect a variable bias supply (3 to 15V) to the AGC test point with the positive lead to the chassis. Adjust bias until audio signal distorts on peaks slightly, then adjust core of L301 to curb distortion. Repeat this procedure several times at increased bias levels until maximum clarity of audio is obtained.
4. Adjust the bottom core of T154, repeating the bias advances in step 3, to achieve the optimum setting for noise-free performance at low signal levels.

VOLUME TV-24, ADDITIONAL 1965 TELEVISION SERVICING INFORMATION

GENERAL ELECTRIC Chassis DB Schematic Diagram

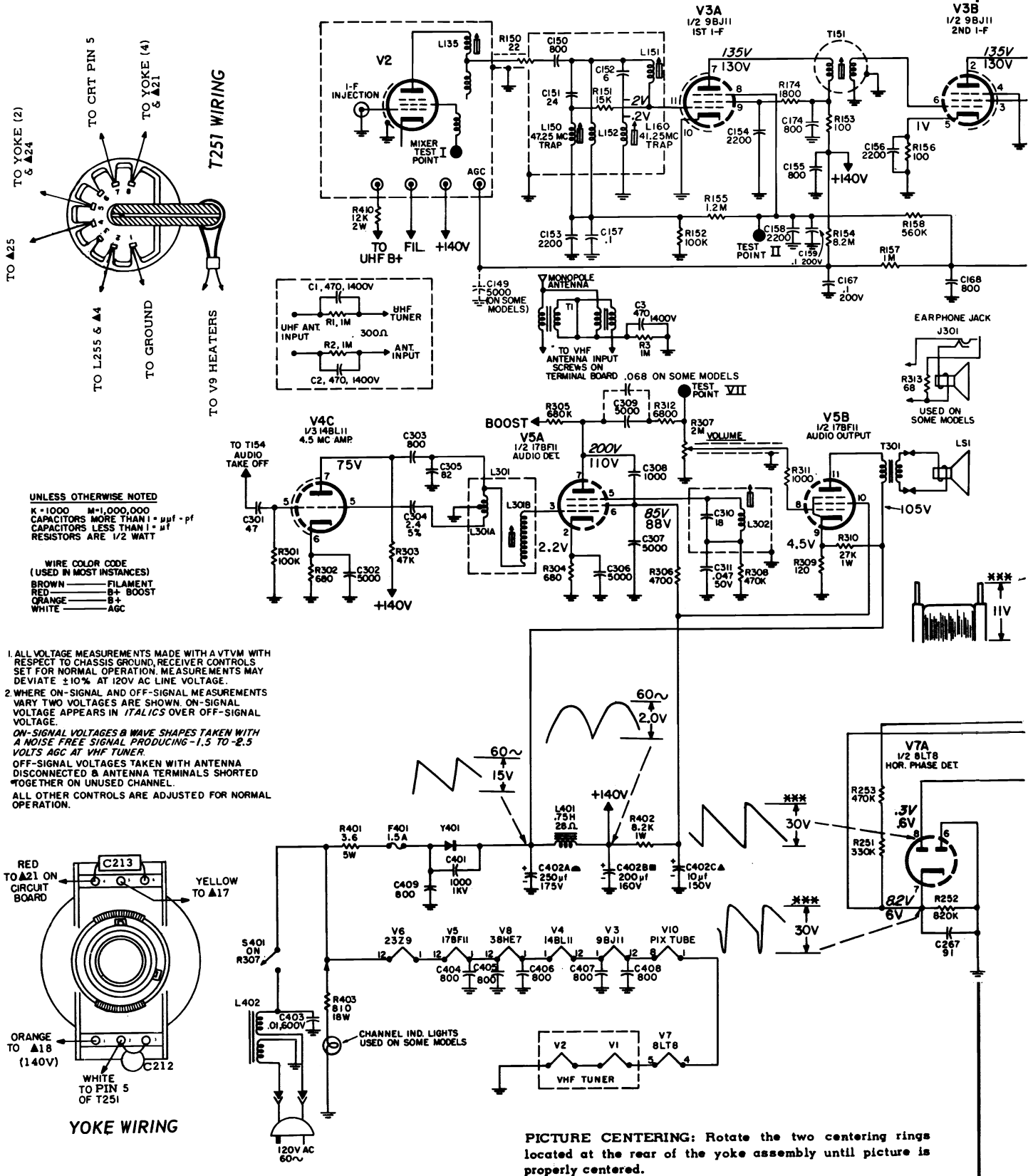

- ALL VOLTAGE MEASUREMENTS MADE WITH A VTVM WITH RESPECT TO CHASSIS GROUND, RECEIVER CONTROLS SET FOR NORMAL OPERATION, MEASUREMENTS MAY DEVIATE ± 10% AT 120V AC LINE VOLTAGE.
 - WHERE ON-SIGNAL AND OFF-SIGNAL MEASUREMENTS VARY TWO VOLTAGES ARE SHOWN, ON-SIGNAL VOLTAGE APPEARS IN *ITALICS* OVER OFF-SIGNAL VOLTAGE.
- ON-SIGNAL VOLTAGES & WAVE SHAPES TAKEN WITH A NOISE FREE SIGNAL PRODUCING -1.5 TO -2.5 VOLTS AGC AT VHF TUNER.*
OFF-SIGNAL VOLTAGES TAKEN WITH ANTENNA DISCONNECTED & ANTENNA TERMINALS SHORTED TOGETHER ON UNUSED CHANNEL.
ALL OTHER CONTROLS ARE ADJUSTED FOR NORMAL OPERATION.

PICTURE CENTERING: Rotate the two centering rings located at the rear of the yoke assembly until picture is properly centered.

VOLUME TV-24, ADDITIONAL 1965 TELEVISION SERVICING INFORMATION

GENERAL ELECTRIC Chassis DB Schematic Diagram, Continued

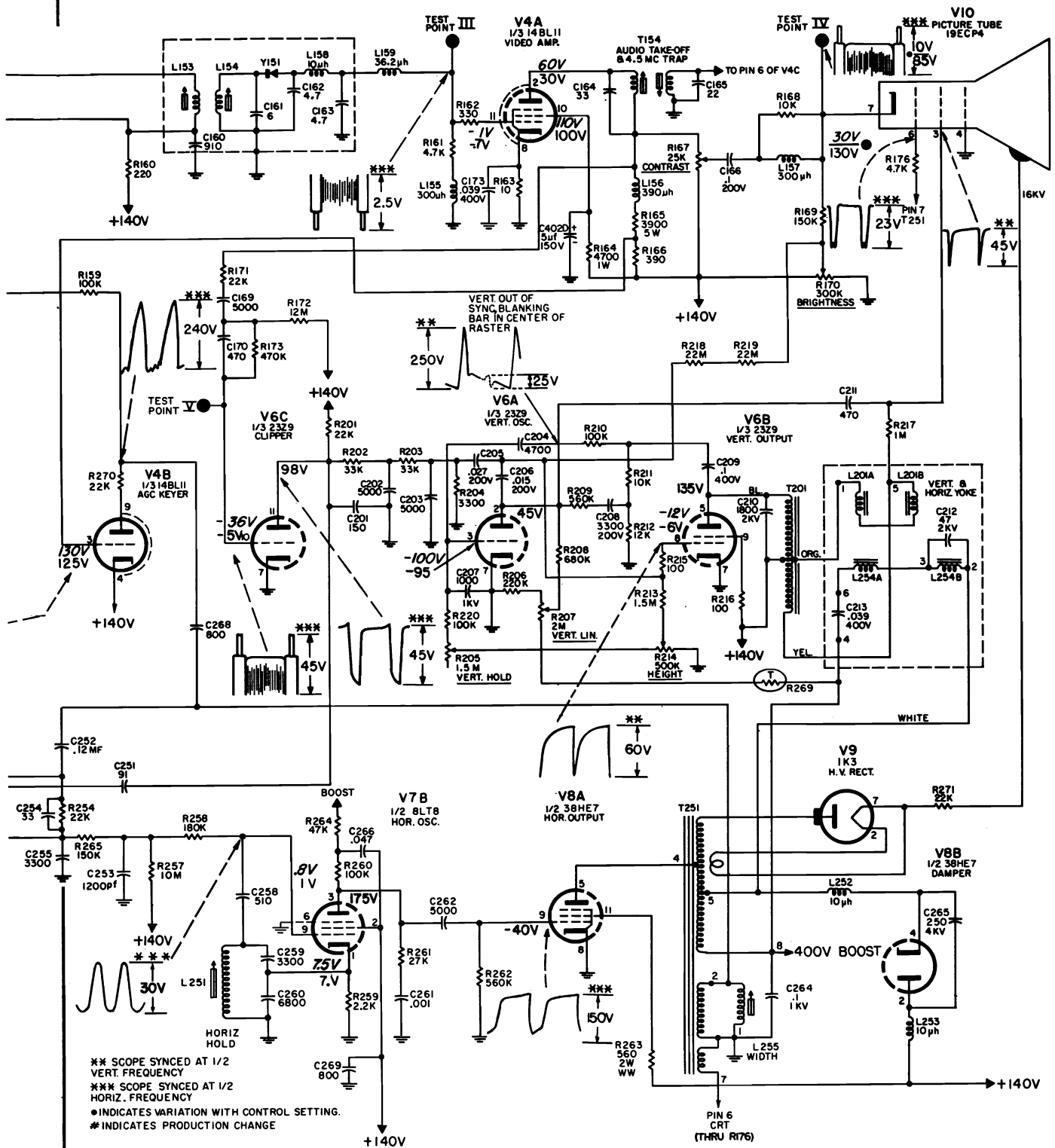

HEIGHT AND VERTICAL LINEARITY: Adjust R214 and R207 simultaneously for proper vertical size and linearity. Picture should extend 1/8-inch beyond top and bottom edges of mask.

HORIZONTAL HOLD: With controls set for normal operation, adjust L251 to the point where the picture "locks in".

PICTURE TILT: To correct picture tilt, loosen the YOKE CLAMP by sliding the eye of the spring over the bend in the clamp. Adjust the yoke to correct the tilt. Secure the yoke by sliding the eye of the spring back over the bend in the clamp.

G. E. Chassis DB, Continued

A B C D E F G H I J K L M N O P Q R S T U V W X

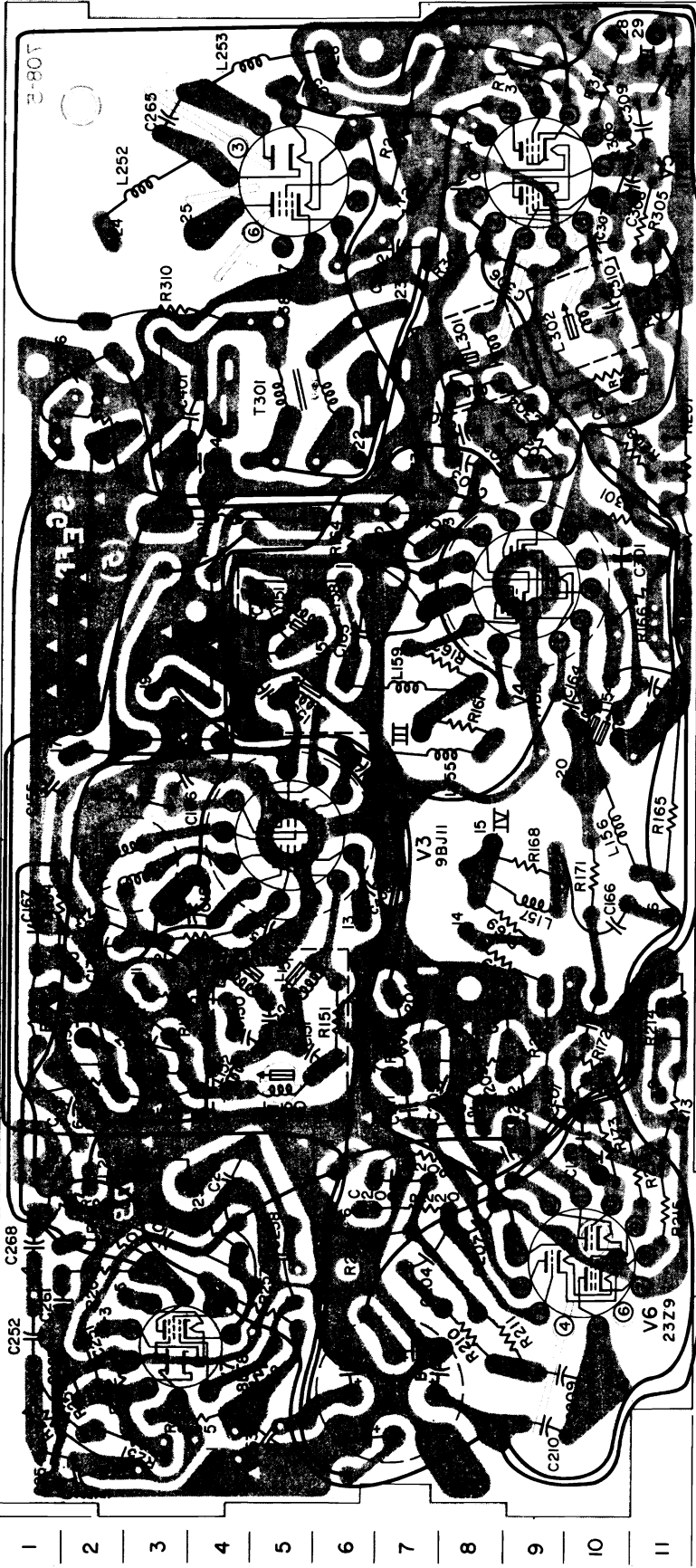

COMPONENT VIEW OF CIRCUIT BOARD

- TRIANGLE (▲) NUMBERS REPRESENT INTERCONNECTING WIRES SOLDERED INTO BOARD TO POINTS INDICATED
- ▲1 BLACK LEADS TO R170-BRIGHTNESS & L402 GND
 - ▲2 BROWN LEAD TO TUNER FILAMENT
 - ▲3 GREY LEAD TO TUNER FILAMENT
 - ▲4 BROWN LEAD TO PIN 1 OF PICTURE TUBE
 - ▲5 BROWN LEAD TO PIN 1 OF PICTURE TUBE
 - ▲6 VIOLET LEAD TO PIN 2 OF PICTURE TUBE
 - ▲7 VIOLET LEAD TO PIN 3 OF PICTURE TUBE
 - ▲8 BLACK LEAD TO PIN 4 OF PICTURE TUBE
 - ▲9 GREEN LEAD TO POS-VERT HOLD-CENTER
 - ▲10 WHITE SHIELD CABLE TO TUNER OUTPUT
 - ▲12 SHIELD GROUND
 - ▲13 BROWN LEAD TO PIN 6 OF PICTURE TUBE
 - ▲14 YELLOW LEAD TO PIN 7 OF PICTURE TUBE
 - ▲15 YELLOW LEAD TO PIN 7 OF PICTURE TUBE
 - ▲16 BLUE LEAD TO R167-CONTRAST-CENTER
 - ▲17 YELLOW LEADS TO T201 & TERM 5 OF YOKE
 - ▲18 ORANGE LEADS TO TERM 1 OF YOKE-TUNER
 - ▲19 R167-CONTRAST
 - ▲20 YELLOW LEAD TO T201-TERM 8
 - ▲21 RED LEAD TO T201-TERM 8
 - ▲22 BLACK LEAD TO SPEAKER
 - ▲23 GREEN LEAD TO SPEAKER
 - ▲24 YELLOW LEAD TO T201-TERM 5
 - ▲25 WHITE LEAD TO T201-TERM 5
 - ▲26 ORANGE LEADS TO T201 & L401
 - ▲27 AUDIO CABLE SHIELD GROUND
 - ▲28 GREEN AUDIO CABLE LEAD TO R307-VOLUME
 - ▲29 YELLOW AUDIO CABLE LEAD TO R307-VOLUME

COMPONENT LOCATION

| TEST POINTS | |
|-------------|--|
| II - H2 | |
| III - M7 | |
| IV - K8 | |
| V - F10 | |
| VII - X11 | |

COILS

| | |
|----------|---------|
| L150-G5 | L160-I4 |
| L151-I5 | L251-F3 |
| L152-H4 | L252-V2 |
| L153-M5 | L253-X4 |
| L154-O5 | L301-S8 |
| L155-L8 | L302-S9 |
| L156-K10 | |
| L157-H2 | |
| L158-M10 | |
| L159-N7 | |

MISC.

| |
|----------|
| F401-P4 |
| Y151-O5 |
| Y401-R3 |
| V3 - K5 |
| V4 - O9 |
| V5 - V9 |
| V6 - D10 |
| V7 - C3 |
| V8 - V5 |

CAPACITORS

| | | | |
|----------|----------|----------|----------|
| C150-H4 | C167-J1 | C251-C2 | C303-Q8 |
| C151-H5 | C168-G2 | C252-C1 | C304-R9 |
| C152-H5 | C169-H10 | C253-B5 | C305-R8 |
| C153-H3 | C170-G10 | C254-A1 | C306-T8 |
| C154-J5 | C173-Q7 | C255-A2 | C307-U10 |
| C155-L1 | C174-I2 | C258-E5 | C308-V10 |
| C156-L3 | C201-F8 | C259-F4 | C309-W10 |
| C157-H3 | C202-I8 | C260-E3 | C310-T10 |
| C158-J4 | C203-H8 | C261-D1 | C311-R10 |
| C159-H2 | C204-D7 | C262-U7 | C401-R3 |
| C160-N5 | C205-G8 | C264-O2 | C402-B7 |
| C161-N5 | C206-G8 | C265-W3 | C404-V8 |
| C162-O4 | C207-E8 | C266-S2 | C405-W6 |
| C163-O6 | C208-F7 | C267-C1 | C407-L6 |
| C164-M9 | C209-C10 | C268-E1 | C408-J6 |
| C165-N11 | C210-B9 | C301-P10 | C409-Q4 |
| C166-J10 | C211-G7 | C302-Q8 | |

RESISTORS

| | | | |
|----------|----------|----------|----------|
| R150-I3 | R168-K9 | R215-E11 | R264-R2 |
| R151-H6 | R169-J9 | R216-F11 | R265-B3 |
| R152-I3 | R171-K10 | R217-H7 | R267-T11 |
| R153-J2 | R172-H10 | R218-H9 | R270-E3 |
| R154-J1 | R173-G10 | R219-I8 | R301-P10 |
| R155-C3 | R174-J4 | R220-F7 | R302-O9 |
| R156-L3 | R201-G9 | R251-B3 | R303-P7 |
| R157-H2 | R202-G9 | R252-B2 | R304-T8 |
| R158-C2 | R203-H8 | R253-B2 | R305-U11 |
| R159-F1 | R204-I7 | R254-B1 | R306-V10 |
| R160-M3 | R206-P11 | R257-D5 | R308-S10 |
| R161-M8 | R208-Q10 | R258-C5 | R309-W9 |
| R162-N8 | R209-F7 | R259-E4 | R310-T3 |
| R163-P7 | R210-C8 | R260-E2 | R311-W10 |
| R164-P6 | R211-C9 | R261-D2 | R312-X11 |
| R165-L11 | R212-E6 | R262-U7 | R401-N4 |
| R166-O11 | R213-G11 | R263-V7 | R402-X8 |

GENERAL ELECTRIC

Chassis TA, used in Models TR803ABG, TR805AEB
(Service material on pages 45 through 52)

DISASSEMBLY

TO REMOVE AND REPLACE THE CABINET BACK

To remove the cabinet to service the chassis use the following procedure. Place the receiver face down on a clean soft pad or cloth on the workbench. Loosen the antenna terminal screws and disconnect the antenna leads. Remove the power cord by unplugging. Remove all of the side panel control knobs. Remove the five phillips head screws from the back and two from the bottom front corners of the mask.

CAUTION! Before attempting to remove the cabinet, be sure the carrying handle is pulled and held in the out position. Now carefully lift the cabinet up and away from the chassis and set aside. To reassemble the cabinet to the chassis reverse the procedure.

SERVICING THE CIRCUIT BOARD

The TA chassis circuit board can be lowered to a 45 degree angle for ease of service. To do this proceed as follows. Remove the two self-tapping screws which secure the circuit board to the main chassis side panels. There are five ground straps used to ground the IF shields to the chassis. Remove the four self-tapping screws that secure these straps to the left chassis side panel. The circuit board is now free to be lowered to the service position.

TO REMOVE THE PICTURE TUBE

Position the receiver so that the picture tube rests on a clean soft pad on the workbench. Remove the picture tube socket. Loosen the screw in the yoke clamp. Remove the four self-tapping screws which secure the two chassis side panels to the picture tube mask corner brackets. Discharge the picture tube anode lead to the chassis, then disconnect the anode lead. Carefully lift the chassis and the yoke up and away from the picture tube neck. Set chassis aside. Remove the self-tapping screw from the picture tube sling. Remove the four screws securing the sling tabs to the mask. Lift sling up and away from the picture tube. The tube is now free to be removed. To reassemble use the reverse procedure.

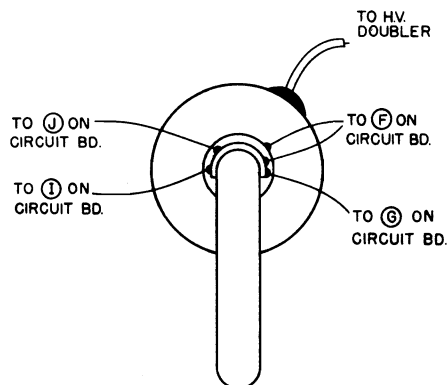

HORIZONTAL OUTPUT TRANSFORMER WIRING

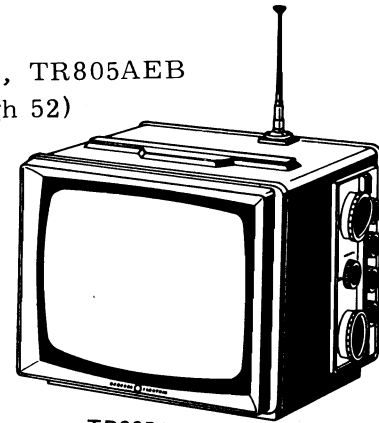

TR805AEB

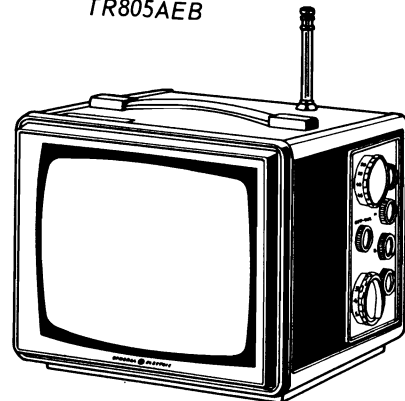

TR803ABG

CAUTION! This receiver is designed to be used in an automobile which has a 12 volt, negative ground electrical system. If the receiver is connected to the electrical system of an automobile with a positive ground, it will blow the protection fuse which is located inside the receiver.

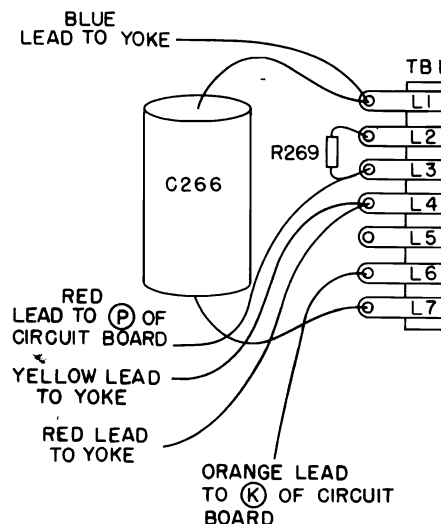

WIRING DIAGRAM FOR TERMINAL BOARD NO. 1

VOLUME TV-24, ADDITIONAL 1965 TELEVISION SERVICING INFORMATION

GENERAL ELECTRIC Chassis TA Alignment Information VIDEO IF SYSTEM

AM PRE-PEAKING FREQUENCIES

| | |
|-----------|------------------|
| L107..... | Min. at 47.25 MC |
| L106..... | Min. at 41.25 MC |
| L56..... | Max. at 45.00 MC |
| T105..... | Max. at 44.15 MC |
| T106..... | Max. at 44.15 MC |
| T107..... | Max. at 44.15 MC |
| L108..... | Max. at 44.00 MC |

Note: Allow the receiver and test equipment at least 20 minutes to warm up. Caution! The cores in the IF coils are brittle. Do not use a metal driver when adjusting these cores.

1. Set channel selector to the thirteenth position. (UHF) Set the volume control to a (fully counterclock wise) position and contrast control to a (fully clockwise) position.
2. Short the VHF antenna terminals together and leave them shorted throughout the entire video alignment.
3. Connect an oscilloscope through a 10K resistor to Test Point III. Connect the positive terminal of a 3.5 volt bias supply to the IF AGC Test Point II and the negative terminal to chassis ground. Use a battery with the appropriate potentiometer across it as an adjustable, low impedance bias voltage source.
4. Inject signals from a properly terminated AM. signal generator or from a 40-50 MC. sweep generator through the network shown to the UHF IF input point on the VHF tuner terminal strip.
5. Align the receiver to produce the response curve illustrated.

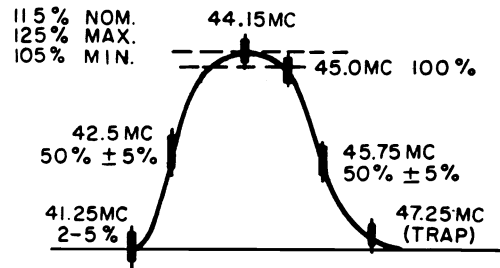

I-F RESPONSE CURVE

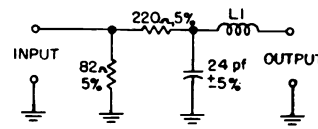

NOTE: Coil L1 is ordered from your General Electric distributor. Catalog number is ET36X733.

I-F INJECTION NETWORK

VIDEO IF ALIGNMENT CHART

| STEP | SIGNAL FREQUENCY | ADJUST | REMARKS |
|------|--|--|--|
| 1. | 47.25 MC AM | Adjust L107 for minimum scope deflection | Use maximum scope sensitivity and smallest possible signal for the 47.25 MC AM adjustments |
| 2. | 41.25 MC AM | Adjust L106 for minimum scope deflection | Use maximum scope sensitivity and smallest possible signal for the 41.25 MC AM adjustments (core should be toward outside of the coil) |
| 3. | 38-48 MC sweep Generator with scope calibrated 1.5 volts p-p for a 2 inch deflection; Markers at 41.25, 42.5, 44.15 and 45.75 MC | Adjust L156 (converter plate) for maximum output at 45.0 MC | Use sufficient signal strength to give a 2 inch scope deflection at Test Point III |
| 4. | SAME | Tune T105 and T106 for maximum scope deflection at 44.15 MC | T105 and T106 cores should be positioned away from the board |
| 5. | SAME | Adjust T107 top and bottom for maximum scope deflection at 44.15 MC marker | T107 top core should be positioned away from the board, bottom core will be near the board |
| 6. | SAME | Adjust L108 for a compromise between 45.0 MC and a round nose | L108 should rock the nose around a pivot at 44 MC |

NOTE: Symmetry of the nose is very important, no position of the nose should be asymmetrical or tilted more than 5%.

AUDIO ALIGNMENT

NOTE: Allow the chassis and test equipment at least 20 minutes to warm up. Prepare the chassis to be aligned in the following manner.

1. Connect an oscilloscope to Test Point V.
2. Connect a DC volt meter (0-1V, 1%) between Test Point VII and ground.
3. Connect a VTVM between Test Point VI and ground.
4. Place a jumper wire from Test Point II to ground.
5. Feed in a 4.5 MC AM signal at Test Point III through a 100µf capacitor.
6. Adjust T108, T300 and T301 for maximum reading of the VTVM at Test Point VI. Note: Proper core position of T300 is with the core toward the top of the can. For T301 the Ratio Detector Transformer, the cores should be away from each other. The DC voltage at Test Point VI should be kept at 1.0 volt.
7. Adjust T301 bottom slug for minimum AM output observed on the oscilloscope on Test Point V.
8. With no signal input, adjust R321 the audio bias control, for a 0.3 volt reading on the DC meter at Test Point VII.

GENERAL ELECTRIC Chassis TA Circuit Board Information

TRIANGLE (▲-O) NUMBERS

REPRESENT WIRE WRAP TERMINALS ON COMPONENT BOARD FOR CONNECTION OF WIRES TO POINTS INDICATED.

- ▲ 1. GREEN LEAD TO HORIZ. HOLD POT
- ▲ 2. BLUE LEAD TO HORIZ. HOLD POT
- ▲ 3. BLUE LEAD TO VERT. HOLD POT
- ▲ 4. ORANGE LEAD TO VERT. HOLD POT
- ▲ 5. BLUE LEAD TO L201
- ▲ 6. GREEN LEAD TO VERT. HOLD POT
- ▲ 7. GREEN LEAD TO L201
- ▲ 8. GREEN LEAD TO L202(YOKE)
- ▲ 9. YELLOW LEAD TO CONTRAST POT

CIRCLED (A) LETTERS

REPRESENT INTERCONNECTING WIRES SOLDERED INTO BOARD

- (A) GREEN LEAD TO BASE OF Q24
- (B) YELLOW LEAD TO EMITTER OF Q24
- (C) YELLOW LEAD TO PIN #2 PICTURE TUBE SOCKET
- (D) BLACK LEAD TO CHASSIS SIDE PANEL
- (E) RED LEAD WITH WHITE TRACER TO BRIGHT POT
- (F) TO T251
- (G) TO T251
- (H) WHITE LEAD TO HIGH VOLTAGE DOUBLER CIRCUIT
- (I) TO T251
- (J) TO T251
- (K) ORANGE WIRE TO TBI-L6
- (L) WHITE LEAD TO VHF TUNER (AGC)
- (M) YELLOW SHIELDED LEAD TO VOLUME POT
- (N) GREEN SHIELDED LEAD TO CENTER TERM. VOL.
- (O) SHIELD OF AUDIO CABLE TO VOL POT
- (P) RED LEAD TO TBI-L3
- (Q) RED LEAD TO BRIGHT POT
- (R) GREEN LEAD TO PIN #1 PICTURE TUBE SOCKET
- (S) ORANGE LEAD TO VHF TUNER (+12V)
- (T) GREEN LEAD TO EARPHONE JACK
- (U) VIOLET LEAD TO EARPHONE JACK
- (V) ORANGE LEAD TO COLLECTOR OF Q21
- (W) GREEN LEAD TO BASE OF Q21
- (X) YELLOW LEAD TO EMITTER OF Q21
- (Y) SHIELD OF I-F INPUT LINK CABLE
- (Z) CENTER CONDUCTOR OF I-F INPUT CABLE

TRANSISTORS

- Q4-O8
- Q5-O6
- Q6-O3
- Q7-N2
- Q8-M1
- Q9-I4
- Q10-H3
- Q11-J2
- Q12-K3
- Q13-L6
- Q14-J8
- Q15-I8
- Q16-J10
- Q17-G2
- Q18-F6
- Q19-F10
- Q20-N11
- Q22-C1
- Q23-A2

TEST POINTS

- II - P6
- III - M2
- IV - M1
- V - J7
- VI - I6
- VII - J9
- VIII - G2
- IX - E8
- X - D2
- XI - B1
- XII - B7

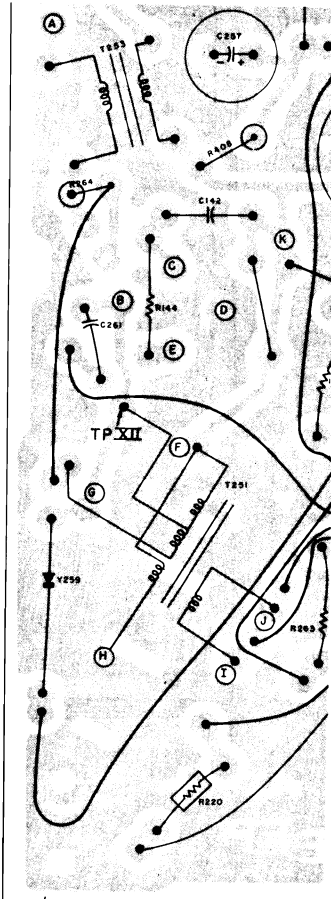

AFTER CODE DATE 445

GENERAL ELECTRIC Chassis TA Circuit Board Data, Information

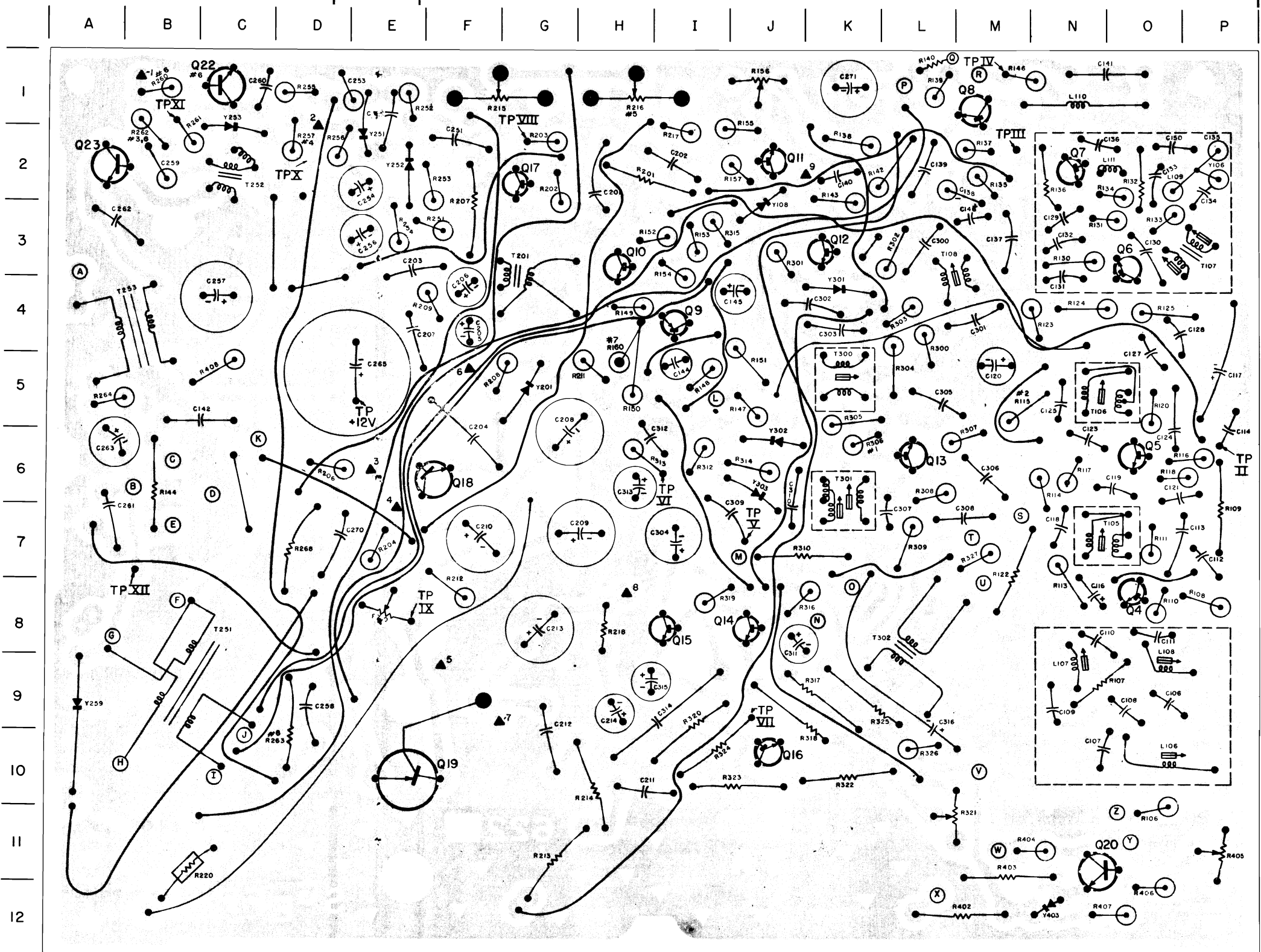

CIRCUIT BOARD VIEWED FROM COMPONENT SIDE

VOLUME TV-24, ADDITIONAL 1965 TELEVISION SERVICING INFORMATION

GENERAL ELECTRIC Chassis TA Schematic Diagram

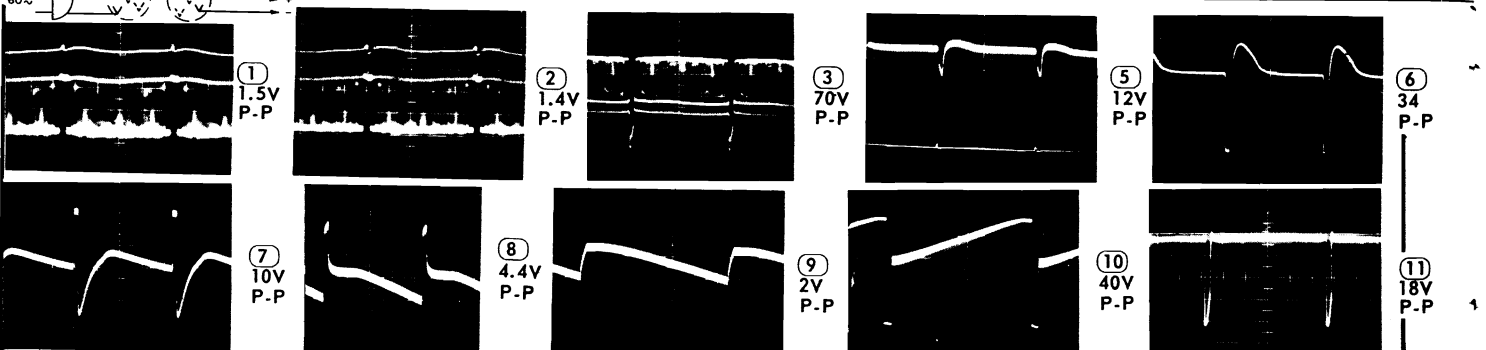
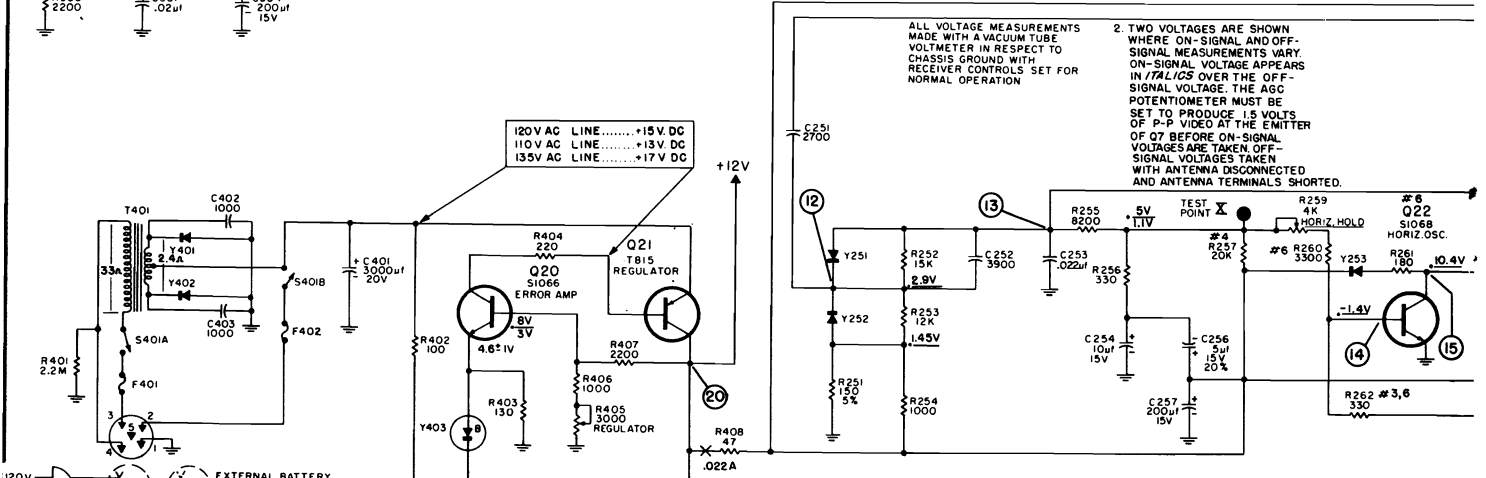
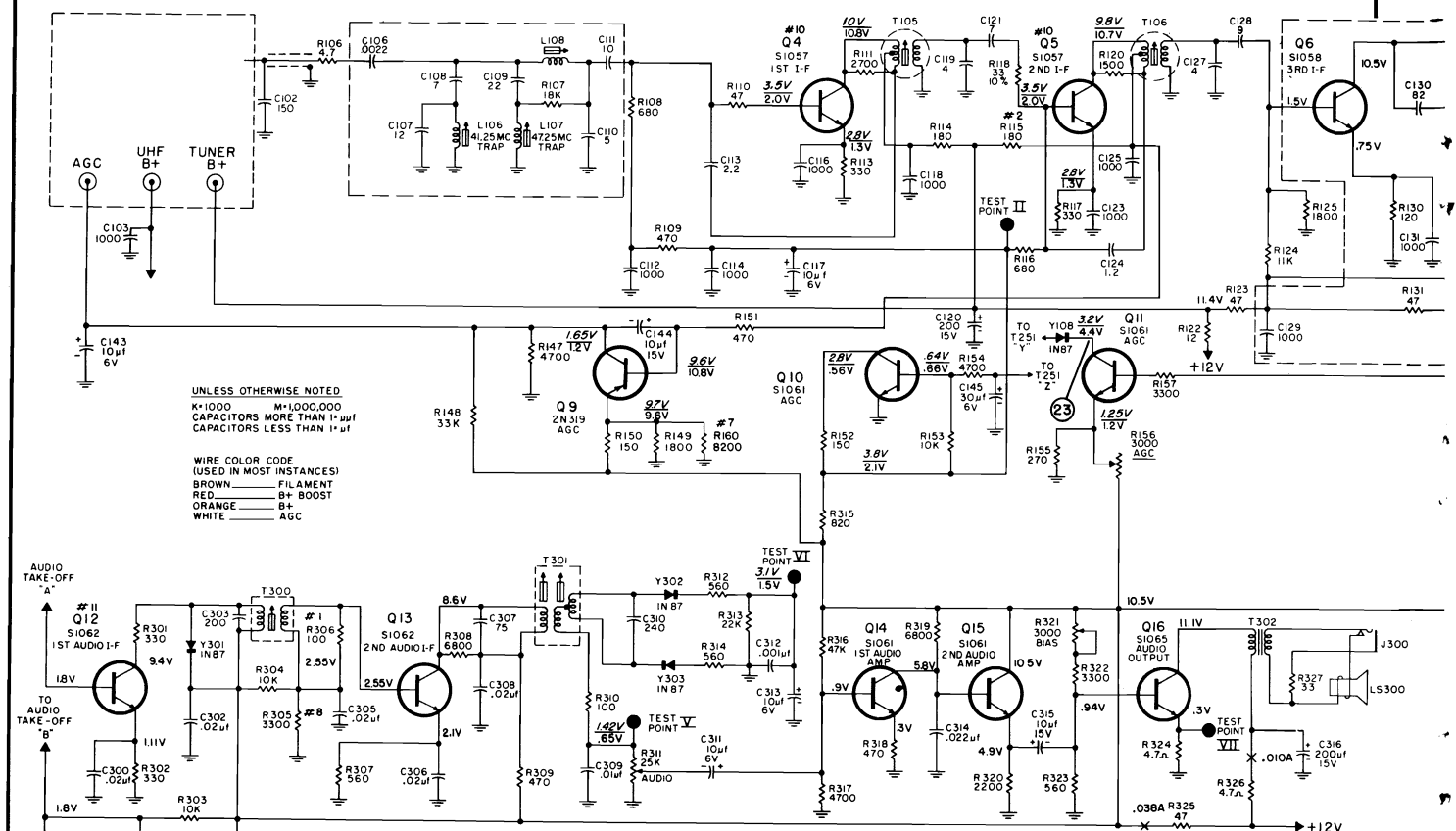

OSCILLOSCOPE AT VERTICAL RATE

VOLUME TV-24, ADDITIONAL 1965 TELEVISION SERVICING INFORMATION

GENERAL ELECTRIC Chassis TA Schematic Diagram, Continued

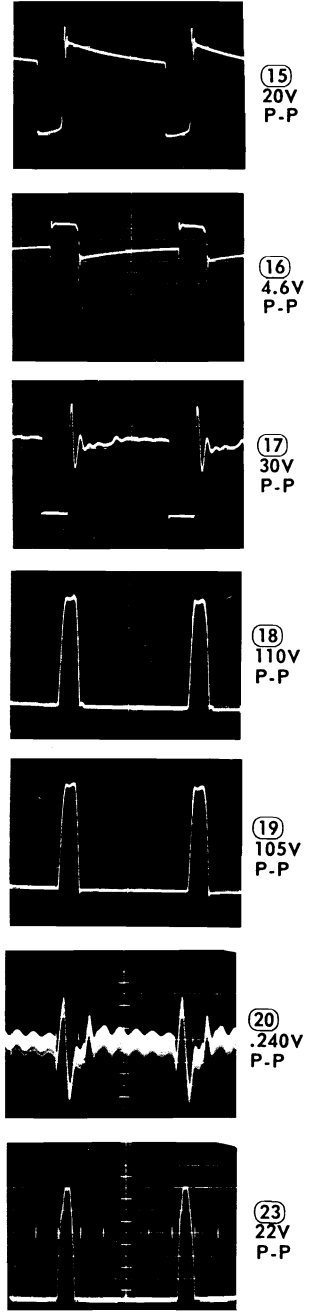
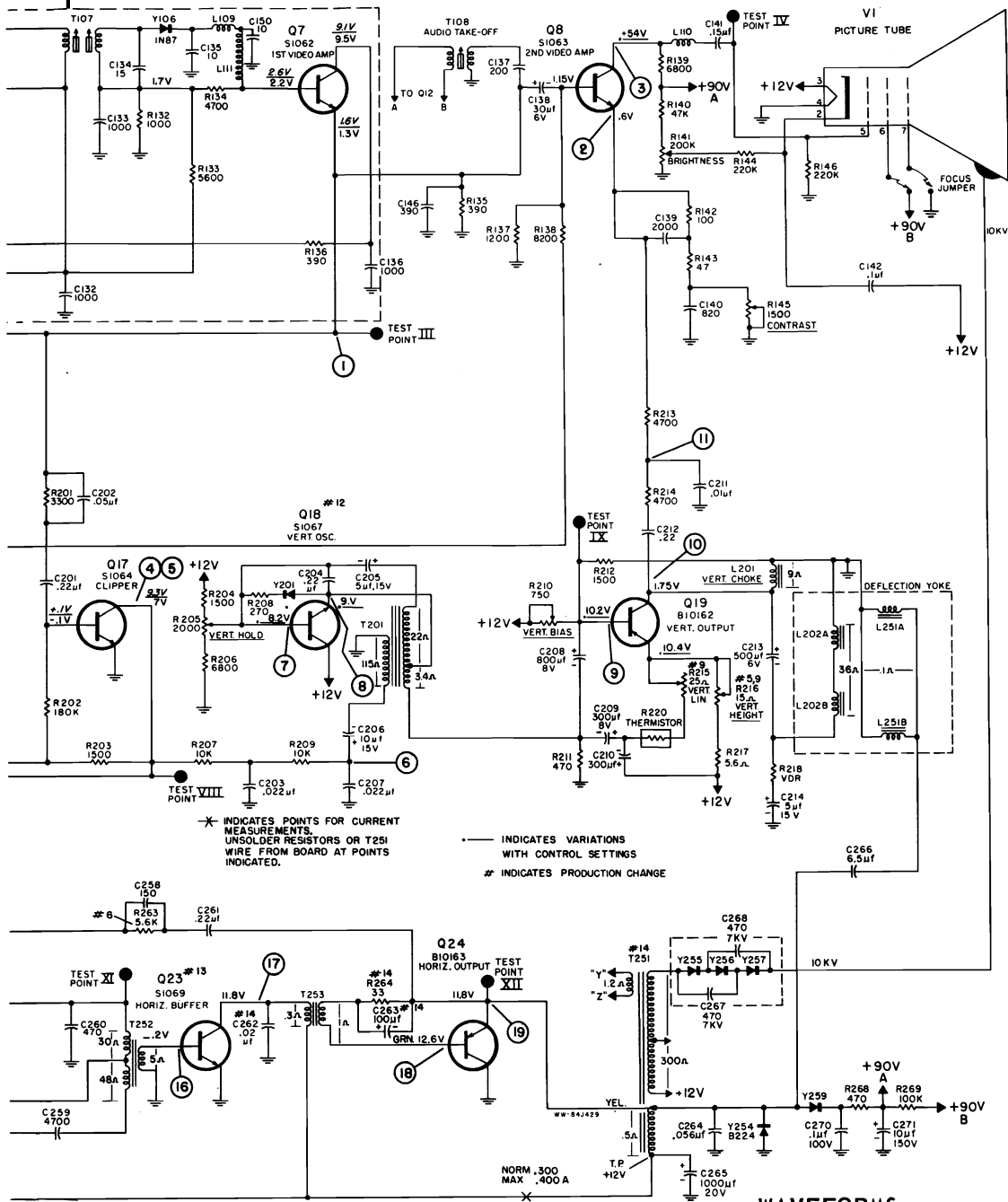

* INDICATES POINTS FOR CURRENT MEASUREMENTS. UNSOLDER RESISTORS OR T251 WIRE FROM BOARD AT POINTS INDICATED.
 — INDICATES VARIATIONS WITH CONTROL SETTINGS
 # INDICATES PRODUCTION CHANGE

WAVEFORMS

Baloon numbers ①, ②, etc., indicate points to observe waveforms shown on the schematic diagram.

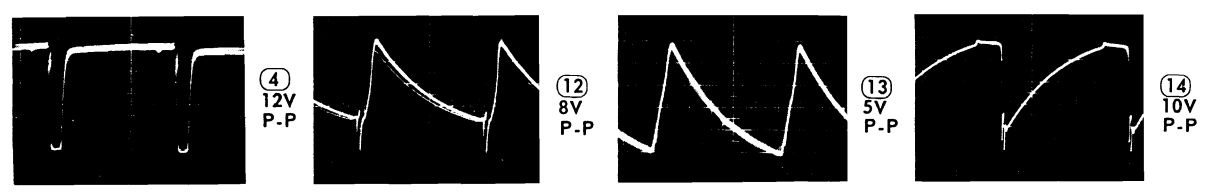

OSCILLOSCOPE AT HORIZONTAL RATE

VOLUME TV-24, ADDITIONAL 1965 TELEVISION SERVICING INFORMATION

GENERAL ELECTRIC Chassis TA Production Changes

The production code number is used to show the approximate point in production where a change occurred. The code number is stamped on the right chassis side panel adjacent to the VHF tuner shaft.

Changes are listed in the order in which they occurred in production and are keyed by a change number. This number is used as a convenient means of keying replacement parts to the proper production change.

Due to variations in component tolerance R160, a 8.2K resistor, is added in shunt with R149 in the emitter circuit of Q9 to provide a means of adjusting the required forward bias voltage necessary to cause Q9 to conduct. This resistor is primarily a factory adjustment, in that it may be clipped from the circuit or left in tact, whichever the case may be, to provide the desired operating point for Q9.

NOTE #1

When Q5, the second IF amplifier, is replaced, check the circuit board to see if both ends of R160 are connected to the copper pattern. Clipping of this resistor was a factory adjustment. If one end is not connected, connect it to the proper point by referring to the schematic diagram or circuit board layout in the service information. Apply power to the receiver, tune in the strongest signal in the area and adjust the AGC control R156 to produce 1.5 volts of composite video at TP111. Observe the picture. If the receiver exhibits an overload condition, "bending of vertical lines and a herringbone pattern", disconnect the resistor. If the receiver does not exhibit the above condition, leave R160 connected.

| CHANGE NUMBER | SYMBOL | ORIGINAL COMPONENT | CHANGE | REMARKS | AFTER CODE DATE |
|---------------|--|--|---|--|-----------------|
| # 1 | R306 | 100 ohms | 68 ohms | | 429 |
| # 2 | R115 | 180 ohms | 220 ohms | | 430 |
| # 3 | R262 | 330 ohms | 100 ohms | | 431 |
| # 4 | R257 | 20,000 ohms | 22,000 ohms | | 431 |
| # 5 | R216 | 15 ohms | 25 ohms | Vertical Height Control | 432 |
| # 6 | Q22 | S1068 | S1064 S1164 S1167 S1143 | If original transistor is marked S1068, replace with ET15X15 only. If original transistor is marked S1064, S1143, S1164 or S1167, replace with ET15X20 only. | 435 |
| | R262 R263 R260 | 100 ohms 5600 ohms 3300 ohms | 680 ohms 4700 ohms 2200 ohms | This resistor change is used with the transistors marked S1064, S1143, S1164 and S1167 only. | |
| # 7 | R160 | None | Added 8200 ohms | This resistor is placed in parallel with R149. See Note #1 below. | 435 |
| # 8 | R305 | 3300 ohms | 1500 ohms | | 437 |
| # 9 | R216 R215 | 25 ohms 25 ohms | 15 ohms 15 ohms | Vertical Height Control Vertical Linearity Control | 438 |
| #10 | Q4, Q5 | ET15X6 (S1057) | ET15X21 (S1153) | ET15X6 and ET15X21 are interchangeable. | 439 |
| #11 | Q12 | ET15X7 (S1062) | ET15X23 (S1227) | ET15X7 and ET15X23 are interchangeable. | 439 |
| #12 | Q18 | ET15X14 (S1067) | ET15X24 (S1143) | ET15X14 and ET15X24 are interchangeable. | 439 |
| #13 | Q23 | ET15X16 (S1069) | ET15X24 (S1143) | Use only ET15X24 after code date 439. | 439 |
| #14 | C262 C263 R264 T251 T253 | .02 mfd 100 mfd 33 ohm ET77X85 ET51X20 | 3900µmf Deleted 4.7 ohm 10% 1W ET77X87 ET51X22 | A copper pattern change was also incorporated with the listed component change. | 445 |

T251 WIRING AFTER CODE DATE 445

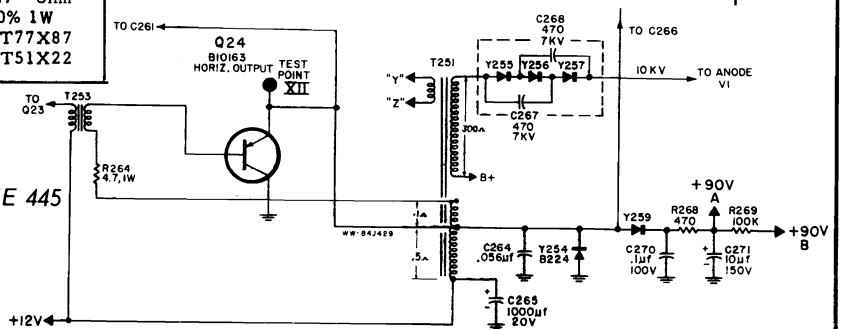

Magnavox

44 SERIES TELEVISION CHASSIS

SPECIFICATIONS

The 44 Series Television Chassis are deluxe transformer powered chassis featuring printed-wiring construction. VHF versions employ 17 tubes (VHF/UHF versions 18) and a single Silicon Diode as a Rectifier. A single rectifier is used since most of the tubes used are designed to function normally with approximately 150V on the plate.

Various types of VHF tuners are used in these chassis. Some chassis may use a "Push-to-Tune" fine-tuning arrangement. On these tuners, merely pressing in and rotating the Fine Tuning knob automatically adjusts

the oscillator slug for the channel to which the tuner is set. Other tuners also have an automatic fine-tuning feature, however, on these tuners it is not necessary to press in on the Fine-Tuning knob in order to adjust the oscillator slugs. Merely rotating the Fine-Tuning knob makes this adjustment adjustment.

Still other VHF tuners used in these chassis have a "manual" fine-tuning arrangement. On these tuners each oscillator slug must be individually adjusted. When adjusting these oscillator slugs, set the Fine-Tuning control to its mid-range position and do not disturb this setting during the adjustment on each channel.

VIDEO BOARD (ALL 31 AND 42 PRODUCTION RUNS)

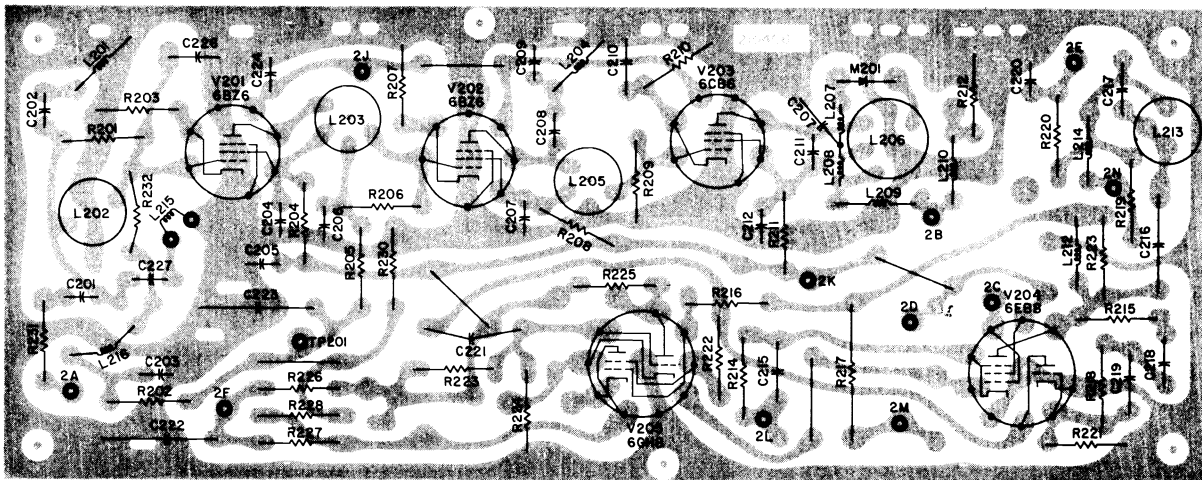

AUDIO BOARD (INTERNAL AUDIO VERSIONS)

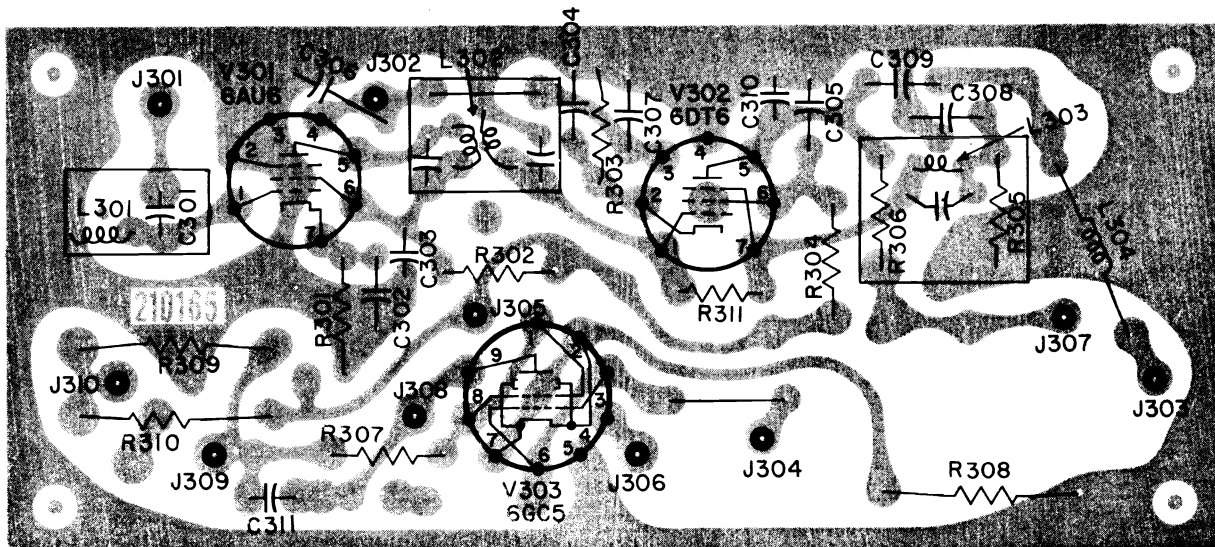

MAGNAVOX Chassis 44 Series, Service Information, Continued

ADJUSTMENTS

FOCUSING--These chassis employ electrostatic focus picture tubes. The focus is accomplished by varying the voltage applied to the focusing anode of the picture tube. On some versions this is accomplished by plugging the focus anode lead into one of three jacks provided. On others a variable Focus Control is provided.

VERTICAL LINEARITY AND HEIGHT--Adjust the height and vertical linearity so that the picture slightly overfills the mask with the linearity uniform from top to bottom. Adjustments of either of these controls may necessitate adjustment of the vertical hold.

HORIZONTAL OSCILLATOR--Turn the horizontal hold control to its mid-range position. Adjust the horizontal frequency coil "slug" until the picture falls into synchronization. Keep adjusting this slug until the picture falls out of sync. Now reverse the direction of adjustment until the picture just pulls into sync. Rotate the hold control to both extremes of rotation. The picture should either stay in sync at both extremes or fall out of sync by an equal number of bars. If either of these conditions fail to appear, repeat the procedure.

CENTERING--To center the raster properly, adjust the two centering rings on the rear of the deflection yoke. They should be rotated about the neck of the tube until proper centering is achieved.

LDR RANGE ADJUST--The following procedure assumes that the adjustment would be made under normal (a bright light) conditions where it would not be possible to darken the room.

As a preliminary step, set the LDR Range control to its maximum clockwise position. Adjust the Brightness and Contrast controls for what would be a normal picture in semi-darkness. If the room lighting cannot be subdued, a semi-darkness condition, insofar as the amount of light striking the LDR, can be assimilated by placing your hand flat over the window of the LDR. Check the contrast to brightness ratio by slowly moving your hand away from the window. If the picture appears too light under normal lighting conditions rotate the LDR Range Adjust control slightly counter-clockwise. Repeat this procedure until the contrast to brightness ratio remains the same throughout the variations in room lighting.

The entire chassis is designed for easy servicing. All tubes plus the Silicon Diode Rectifiers and detector diodes are accessible from the rear of the set. For access to the wiring side the chassis must be removed from the cabinet. There are three printed-wiring boards used, one housing the Sound I-F and Audio Circuits, the second contains Video I-F, Video, Sync and AGC Circuits and the third housing the Vertical and Horizontal Sweep Circuits. Large components such as the sweep output transformers, horizontal output tube, power transformer and electrolytic capacitors are mounted on the main chassis pan.

CHASSIS LAYOUT

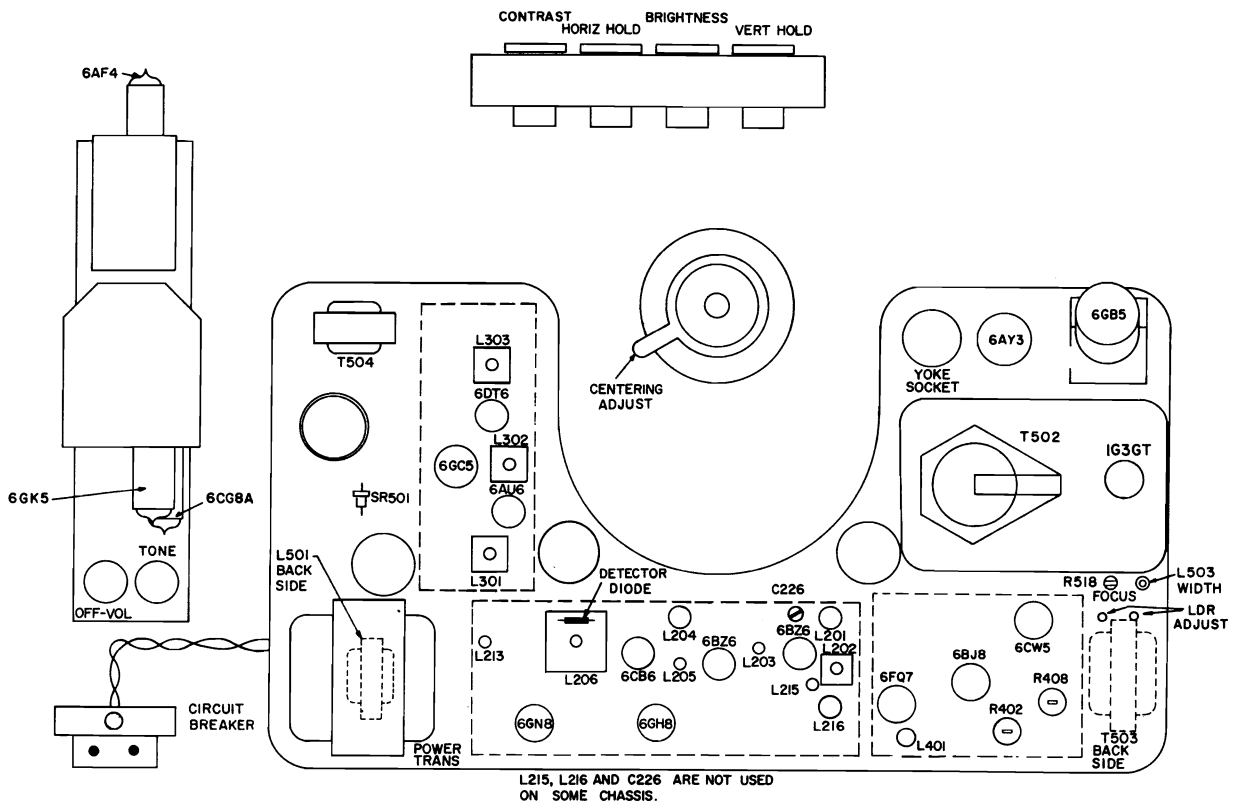

VOLUME TV-24, ADDITIONAL 1965 TELEVISION SERVICING INFORMATION

MAGNAVOX Chassis 44 Series, Alignment Information, Continued

VIDEO ALIGNMENT

- Note 1. Before proceeding with alignment allow a 10 minute warm-up for the chassis and test equipment.
- Note 2. Connect the negative lead of a -2.0 volt bias supply to J210 (RF AGC) and a -3.0 volt bias supply to J211 (IF AGC). Connect the positive leads to ground. Remove the AGC Amplifier tube, 6GH8.
- Note 3. Use only enough sweep generator output to provide a usable pattern on the scope. Set the sweep generator for 10 MC sweep.
- Note 4. All Alignment slugs are accessible from tube side of chassis. Standard Hexagonal Alignment tools are needed with 3/32" and 1/16" tip.
- Note 5. For location of Tuner Plate Coil (L9) and RF Amp Grid Coil (L13) refer to the tuner schematic.

| SWEEP GEN. COUPLING | SWEEP GEN. FREQUENCY | MARKER GEN. COUPLING | MARKER GEN. FREQUENCY | CONNECT SCOPE | ADJUSTMENTS |
|--|---|---|---|---|---|
| 1st I-F grid (Pin 1 of V201). Detune mixer plate coil by adjusting slug fully out. | 43 mc. Adjust gain so trap suckout is visible. | Converter grid (use test point indicated on tuner). | 47.25 mc. Adjust gain so pip is just visible. | I-F Test Point J205. Place 10K res. in series with probe. | Adjust trap L204 to center marker pip in suckout. See Fig. 1. Maximum attenuation is at two positions. Use one with slug farthest out. |
| " | 43 mc Note 3 | " | 42.25 mc 45.0 mc 45.75 mc | " | Check for response curve similar to Fig. 1. Tune L206 for max. gain between 42.25 mc and 45.75 mc. Tune L205 to place 45.75 mc marker at 55% response. Tune L203 to place 42.25 mc marker at 55% response. Repeat adjustments to optimize curve. Recheck 47.25 mc trap. |
| Converter grid (accessible thru hole in top of tuner). | 43 mc Note 3 | Loosely couple to converter tube. | 42.25 mc 45.0 mc 45.75 mc | " | Set VHF Tuner to channel 11*. Tune converter plate coil (L9) for max. gain between 42.25 mc and 45.75 mc markers. *Or to any channel where sweep harmonics do not cause distortion of curve. |
| " | 43 mc Adjust gain for max. with trap suckout still visible on scope. | " | 41.25 mc 47.25 mc 39.75 mc | " | SHORTOUT AGC BIAS. Set VHF Tuner between channels. Adjust trap L201 until 41.25 mc marker falls in center of trap suckout. Adjust L215 until 39.75 mc marker falls in center of trap. Adjust L216 until 47.25 mc marker falls in center of trap suckout. Adjust L202 for maximum attenuation of 47.25 mc. Recheck trap settings. (SEE NOTE A) |
| " | 43 mc Note 3 | " | 45.75 mc | " | Set VHF Tuner to Channel 11. Set Bias as in Note 2. Adjust converter plate coil (L9) and I-F trimmer C226 for max. gain & proper tilt maintaining the 45.75 marker as shown in Fig. 2. (SEE NOTE A) |
| UHF Input on VHF Tuner. Use 1K isolation resistor. | 43 mc Note 3 | " | 45.75 mc 45.0 mc 42.25 mc | " | Set VHF tuner to UHF position. Adjust R-F amp. grid coil (L13) for min. tilt. Response should conform to Figure 2. |

VHF OSCILLATOR ALIGNMENT

| | | | | | |
|--------------------|------------------------|---------------------------------------|---|---|---|
| VHF antenna terms. | Channels 2 thru 13 R-F | Loosely couple to VHF ant. terminals. | Picture and sound carrier for individual channel. | " | Check all channels for bandwidth, slope and position of carrier. Adjust Fine Tuning Control to set Osc. |
|--------------------|------------------------|---------------------------------------|---|---|---|

NOTE A--On some chassis L215, L216, and C226 will not be used. On these chassis it will be necessary to adjust L202, in conjunction with the converter plate coil for maximum gain and proper tilt maintaining the 45.75MC marker as shown in Figure 2. Refer to the schematic diagram covering the chassis being serviced to see which alignment procedure is required.

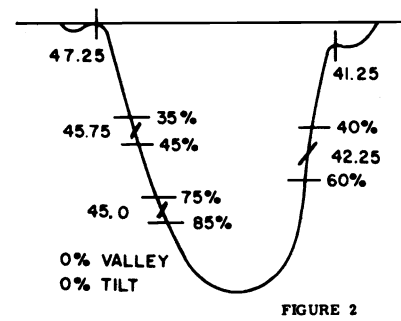
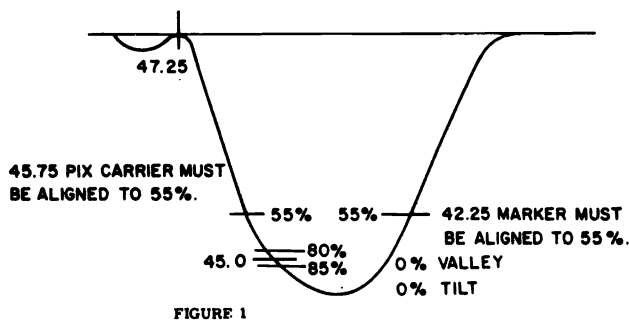

SOUND ALIGNMENT

1. Turn quadrature coil L303 to minimum inductance (core out).
2. Tune receiver to a strong local station (preferably a tone signal or music). Adjust quadrature coil L303 just past the point of maximum sound with minimum distortion.
3. Reduce signal input by removing antenna or placing an adjustable pad across the antenna terminals so that with Volume control set at near maximum, sound is at a low level. Tune the Fine Tuning control through undistorted sound. Set Fine Tuning control to the verge of distortion.
4. Adjust bottom core (grid tuning) of detector drive transformer L302 top core of L302 (plate tuning) and sound take-off coil L301 for minimum distortion.
5. Readjust Fine Tuning control as necessary during adjustment of L301 and L302 to maintain conditions as indicated in step 3 above.

VOLUME TV-24, ADDITIONAL 1965 TELEVISION SERVICING INFORMATION

MAGNAVOX Chassis 44 Series

SCHEMATIC DIAGRAM

44-01-31, 44-03-31, 44-05-31, 44-08-42, 44-09-42, & 44-10-42

NOTE:
TUNER TIE POINTS ARE SHOWN ONLY
TO COMPLETE SCHEMATIC AND DO NOT
SIGNIFY PHYSICAL LOCATIONS.

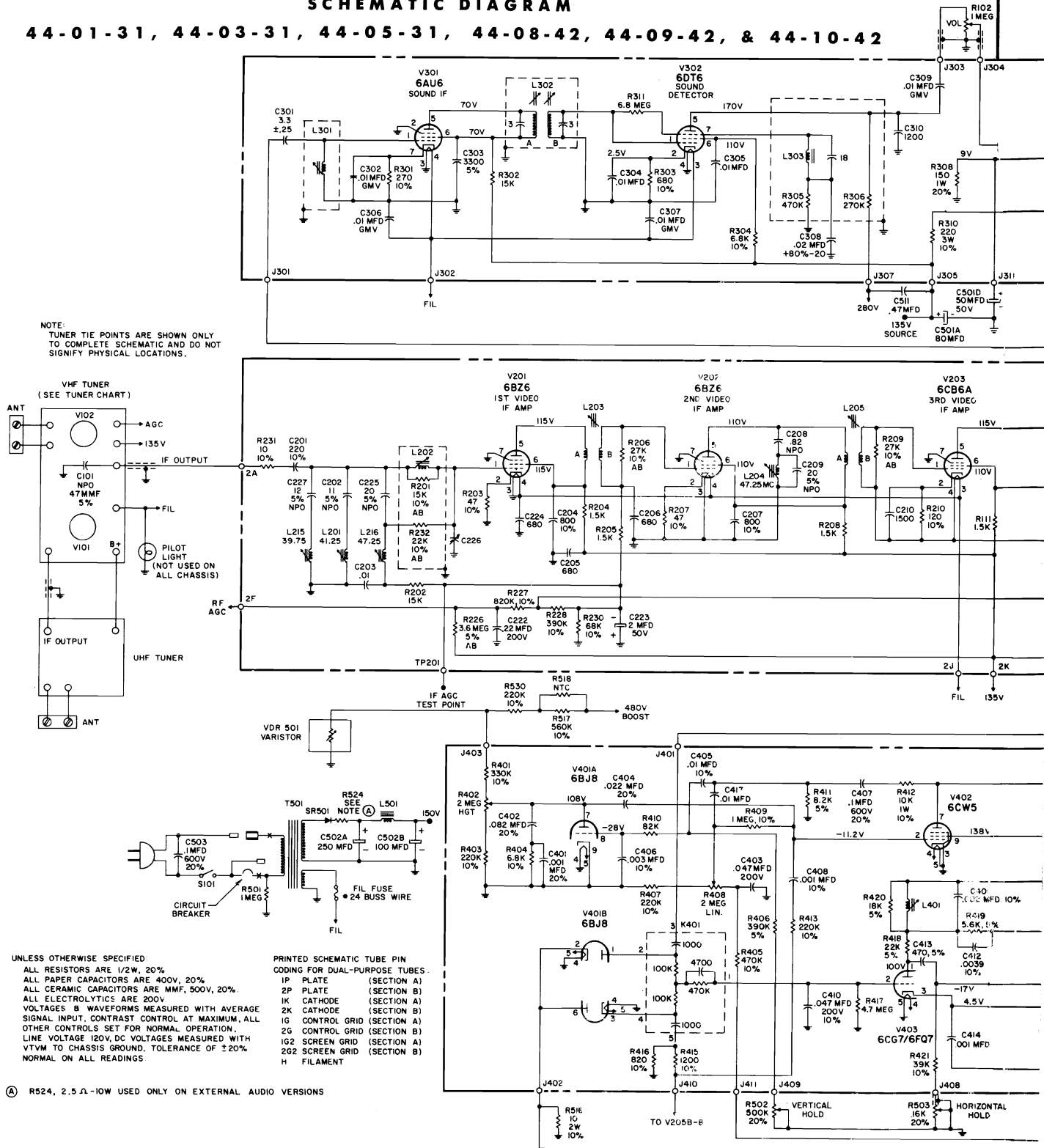

UNLESS OTHERWISE SPECIFIED
ALL RESISTORS ARE 1/2W, 20%
ALL PAPER CAPACITORS ARE 400V, 20%
ALL CERAMIC CAPACITORS ARE MMF, 500V, 20%
ALL ELECTROLYTICS ARE 200V
VOLTAGES B WAVEFORMS MEASURED WITH AVERAGE
SIGNAL INPUT, CONTRAST CONTROL AT MAXIMUM, ALL
OTHER CONTROLS SET FOR NORMAL OPERATION.
LINE VOLTAGE 120V, DC VOLTAGES MEASURED WITH
VTVM TO CHASSIS GROUND, TOLERANCE OF ±20%
NORMAL ON ALL READINGS.

PRINTED SCHEMATIC TUBE PIN
CODING FOR DUAL-PURPOSE TUBES
1P PLATE (SECTION A)
2P PLATE (SECTION B)
1K CATHODE (SECTION A)
2K CATHODE (SECTION B)
1G CONTROL GRID (SECTION A)
2G CONTROL GRID (SECTION B)
1G2 SCREEN GRID (SECTION A)
2G2 SCREEN GRID (SECTION B)
H FILAMENT

(A) R524, 2.5 Ω, -10W USED ONLY ON EXTERNAL AUDIO VERSIONS

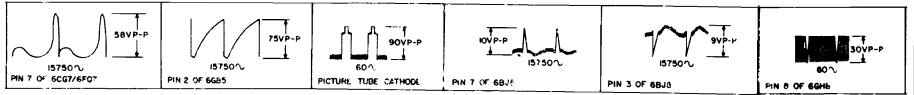

VOLUME TV-24, ADDITIONAL 1965 TELEVISION SERVICING INFORMATION

MAGNAVOX Chassis 44 Series, Schematic Diagram, Continued

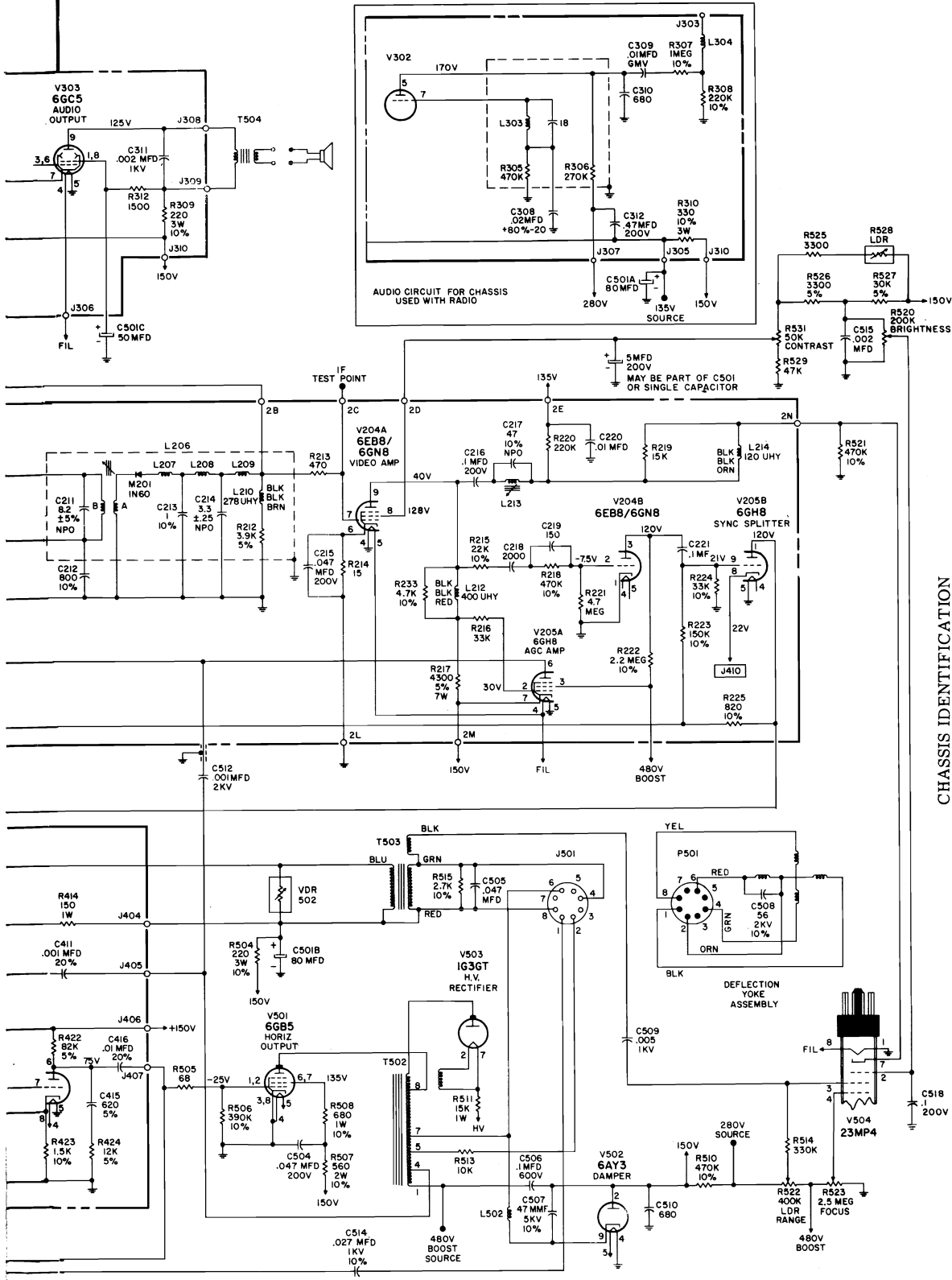

CHASSIS IDENTIFICATION

The chassis are identified by a production code which is stenciled. The first two numbers (40) indicate the basic chassis number. The next two numbers (01 or 02) identify the chassis version within the series. The last two numbers are used to identify the production changes, "00" indicating the initial production run. A change in the first number of the production run code will indicate a major electrical change in the chassis and a change in the second letter will indicate a mechanical change.

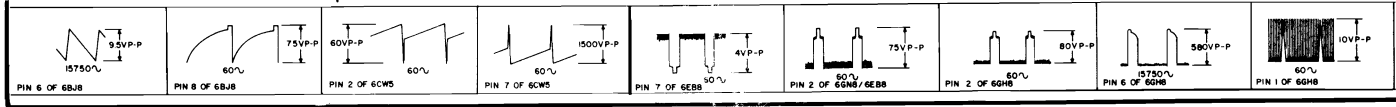

MAGNAVOX Chassis 44 Series, Board Views, Continued

AUDIO BOARD (EXTERNAL AUDIO VERSIONS)

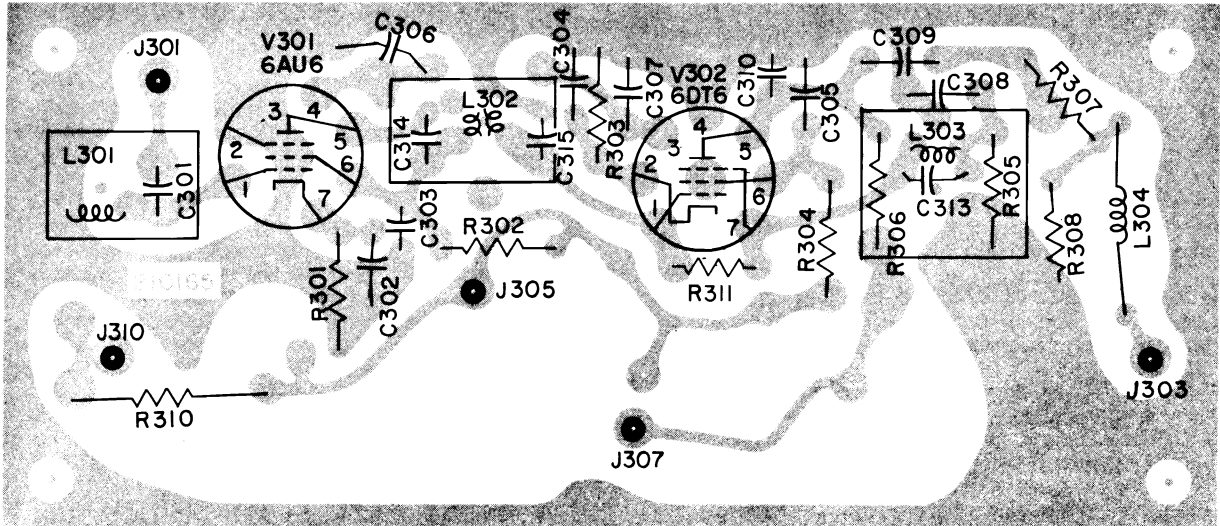

DEFLECTION BOARD (TOP VIEW)

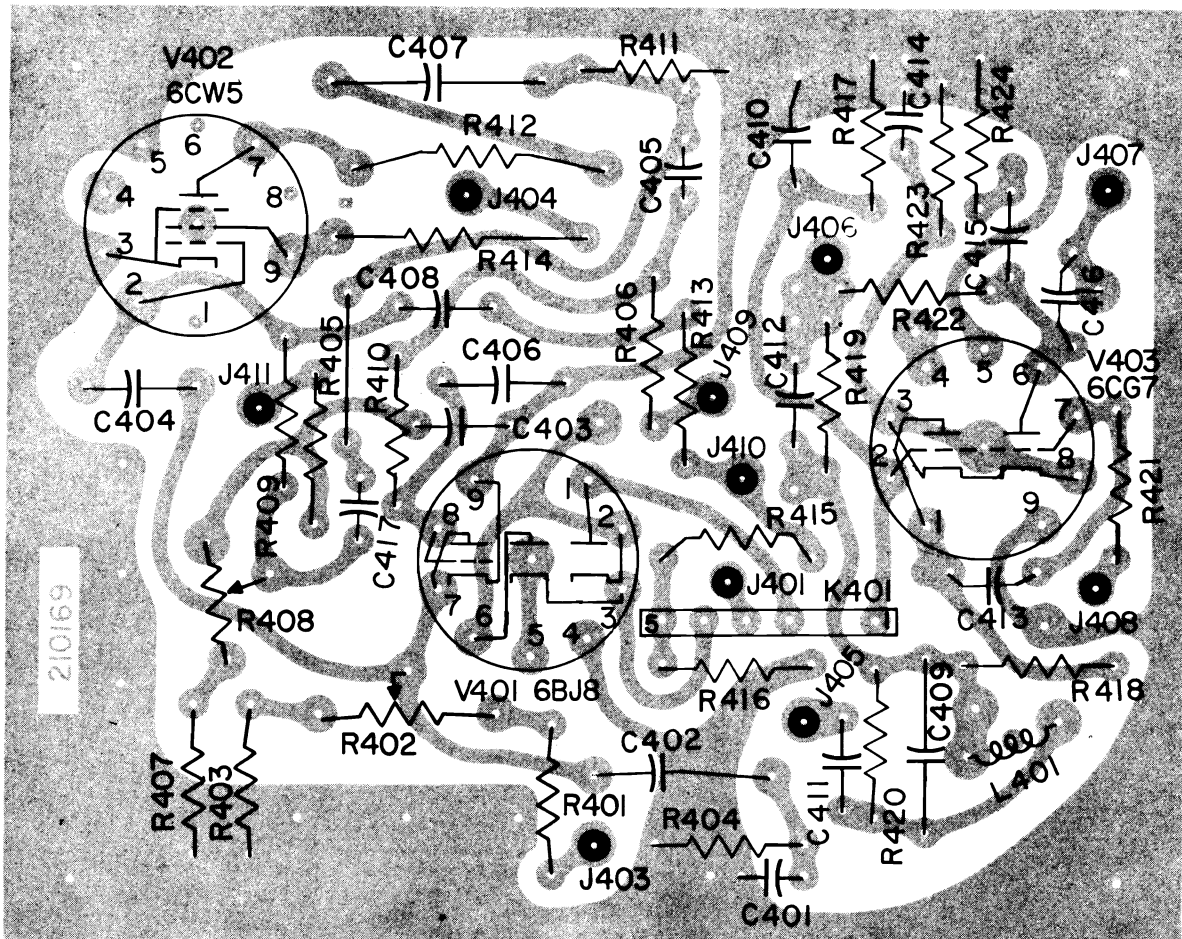

M O N T G O M E R Y W A R D

MODELS WG-4515A, WG-4545A, and WG-4555A

Also Model WG-2785A is a 19" portable with circuitry similar to above.

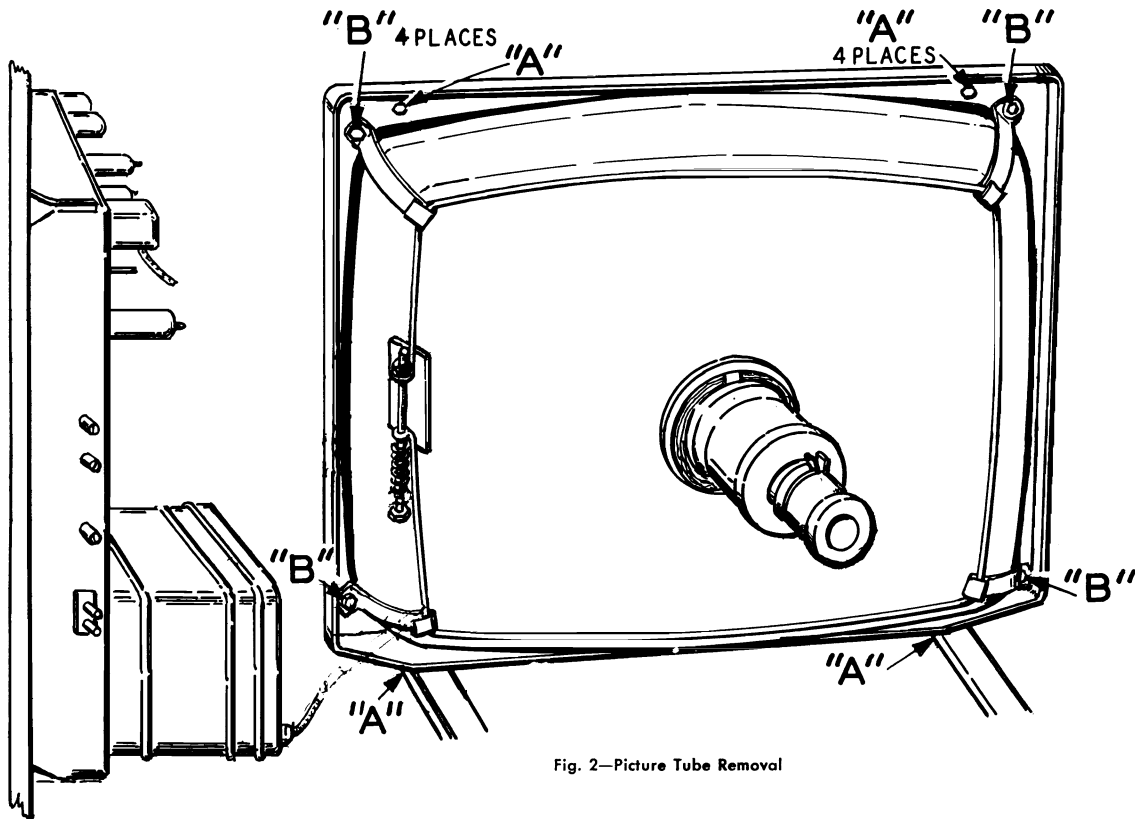

Fig. 2—Picture Tube Removal

INSTRUCTIONS CHASSIS REMOVAL

1. Remove all the knobs from front of cabinet.
2. Remove cabinet back and disconnect the yoke plug, pix tube socket, anode lead, lead from chassis to pix tube mounting ring screw and lead from secondary control mounting bracket.
3. Remove two screws holding secondary control mounting bracket to cabinet.
4. Disconnect the speaker leads.
5. Five screws are used in mounting the chassis to the cabinet. Two screws are located at the front (near the tuner), one screw at the rear, holding brace bracket to the cabinet and the other two screws are accessible through holes in the perforated bottom panel. Remove the five screws and carefully remove the chassis from the cabinet.

PICTURE TUBE REMOVAL AND REPLACEMENT

1. Remove the chassis etc. as outlined in "Instructions Chassis Removal" above.
2. Place the cabinet face down on a cushioned and clean surface so as not to scratch or mar the cabinet.

3. Remove the four (4) screws (marked "A" in illustration) holding entire picture tube frame assembly to the cabinet.
4. Remove the entire picture tube frame assembly from the cabinet and position it on four blocks of wood 2" x 4" x 4" so that each corner of the frame sets on an individual block of wood.
5. Remove the yoke assembly and centering device.
6. Loosen the nut part way on picture tube ring.
7. Remove the four (4) screws (marked "B" in illustration) holding tube clamps in place and lift off the entire mounting ring.
CAUTION — There are tinnerman clips at the rear of the frame. When re-assembling the tube clamps be sure that the tinnerman clips are replaced.
8. Carefully lift the pix tube out.
9. Install the new pix tube.
10. Reverse steps 7 thru 1 to re-assemble all items to the frame and then to the cabinet.
11. WARNING — DO NOT TIGHTEN THE PIX TUBE MOUNTING RING NUT UNTIL YOU ARE SURE THAT THE FOUR (4) PLASTIC INSULATORS ARE IN PLACE BETWEEN THE BRACKET AND THE FRAME. If this precaution is not observed, severe shock may result.

(Continued on pages 60 through 64)

VOLUME TV-24, ADDITIONAL 1965 TELEVISION SERVICING INFORMATION

MONTGOMERY WARD Models WG-4515A, WG-4545A, WG-4555A, Continued

CHECK OF HORIZONTAL OSCILLATOR ALIGNMENT—

Turn the horizontal hold (Fine R-418) control clockwise. The picture should be out of sync with a minimum of 5 or 6 bars slanting downward to the left. Turn the control slowly counter-clockwise. The number of diagonal bars will be gradually reduced and when only 2 to 3 bars sloping downward to the left are obtained, the picture will pull into sync upon slight additional counter-clockwise rotation of the control. Continue turning counter-clockwise until the picture pulls to the right. Turn the control clockwise until the picture is centered and steady. Momentarily remove the signal by switching off channel and then back. The picture should remain in sync. If the receiver passes the above checks and the picture is normal. However, if the conditions described above do not occur, it will be necessary to check the "Horizontal Osc. Coil Adjustment" on this page.

HORIZONTAL OSC. COIL ADJUSTMENT — Short sync out by shorting grid (pin #2) of sync separator (V-301A) to chassis base. Short out horizontal oscillator coil (L-401). Adjust horizontal hold control (Fine R-418) to mechanical center. Then adjust horizontal hold control (Coarse R-417) so that picture is trying to lock in. Remove short across L-401 and adjust core in L-401 so that picture is trying to lock in. Remove short on grid of V-301A. Picture should lock in. The horizontal oscillator coil should never need adjustment after being aligned. If picture does not lock in, check the dual selenium diode and associated circuitry.

HORIZONTAL DRIVE ADJUSTMENT—While receiving a signal from a station with picture locked in sync, turn the horizontal drive control counter-clockwise or clockwise to the point where maximum picture width is obtained.

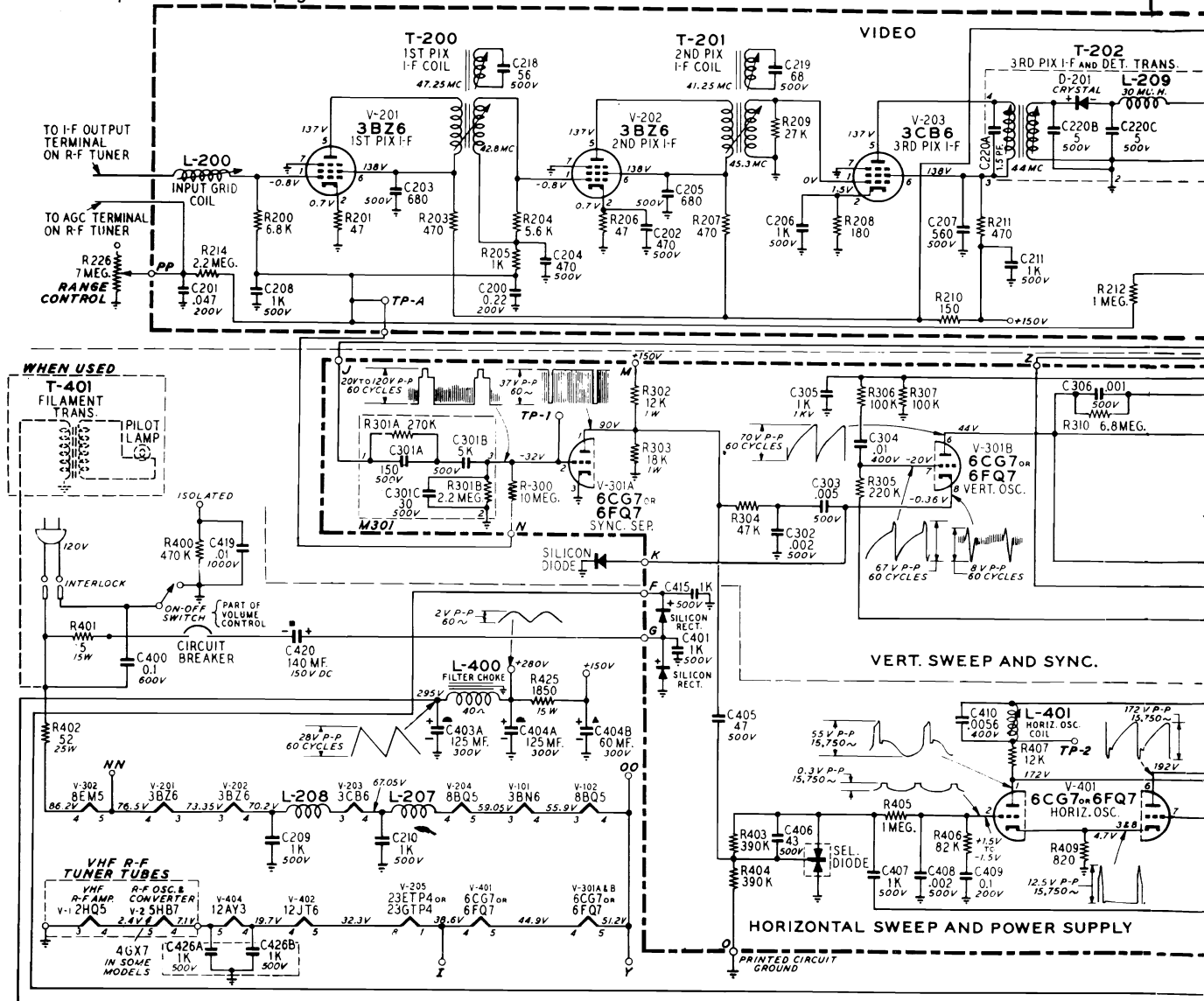

VOLUME TV-24, ADDITIONAL 1965 TELEVISION SERVICING INFORMATION

MONTGOMERY WARD Models WG-4515A, WG-4545A, WG-4555A, Continued

OSCILLOSCOPE WAVEFORM PATTERNS

The waveforms shown on the schematic diagram are as observed on a Tektronix type 524D wide band television oscilloscope with the receiver tuned to a reasonably strong signal and a normal picture. The voltages shown on each waveform are the approximate peak to peak amplitudes. The frequency accompanying each waveform indicates the repetition rate of the waveform not the sweep rate of the oscilloscope. If the waveforms are observed on the oscilloscope with a poor high frequency response, the corners of the pulses will tend to be more rounded than those shown on the schematic diagram and the amplitude of any high frequency pulse will tend to be less.

SCHEMATIC IS DIVIDED INTO FOUR SECTIONS WITH EACH SECTION HAVING ITS OWN SERIES OF REFERENCE NUMBERS.

ALL RESISTANCE VALUES IN OHMS AND HALF WATT UNLESS OTHERWISE SPECIFIED.

ALL CAPACITANCE VALUES LESS THAN 1.0 IN MF. AND ABOVE 1.0 IN PF. UNLESS OTHERWISE NOTED.

COIL RESISTANCE VALUES LESS THAN 1.0 OHM ARE NOT SHOWN.
K=1000 MEG.=1,000,000

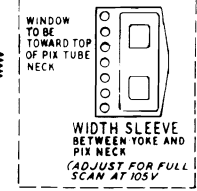
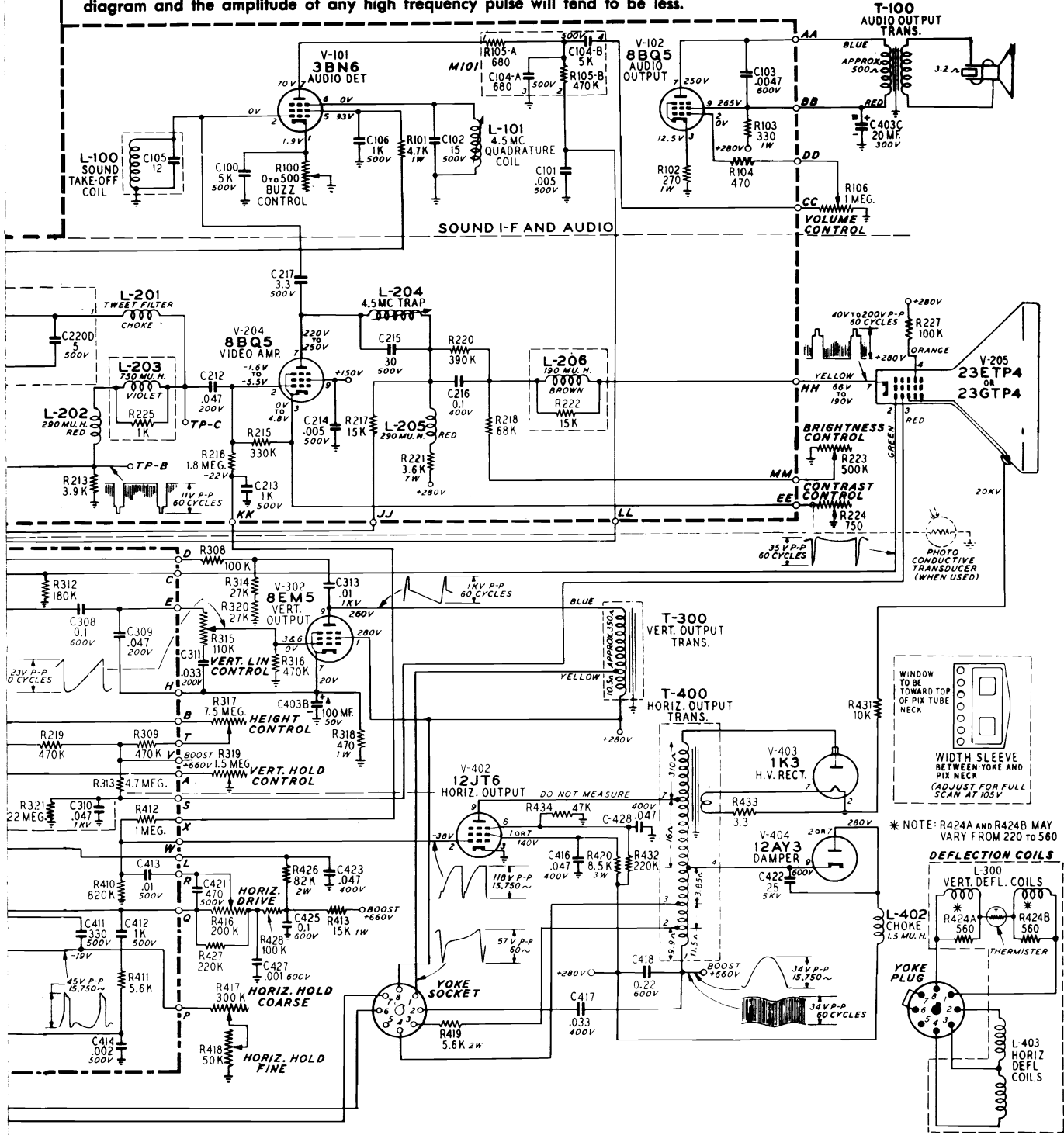

* NOTE: R424A AND R424B MAY VARY FROM 220 TO 560

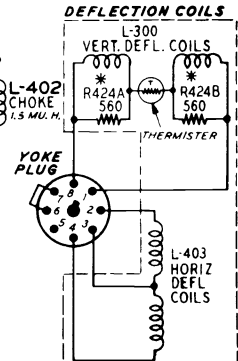

SERVICE ADJUSTMENTS

DEFLECTION YOKE ADJUSTMENT—The deflection yoke should be positioned as far forward on the neck of the tube as the bell will allow. Then, if the lines of the raster are not horizontal or squared with the picture mask, rotate the deflection yoke until this condition is obtained. Upon completion of this adjustment, tighten the clamp at the rear of the deflection yoke.

CENTERING ADJUSTMENT—If horizontal or vertical centering is required this should be done at 105V line (if possible) to obtain normal setting. Adjust each ring in the centering device until proper centering is determined. If centering is not adjusted properly, focus may be poor.

WIDTH SLEEVE ADJUSTMENT—The width sleeve should be adjusted so that the picture just fills the screen at 105V.

PICTURE ADJUSTMENT—For further adjustments, obtain a test pattern on the receiver. When a test pattern is obtained, it may be necessary to slightly re-adjust the fine tuning control for clearest picture.

ADJUSTMENT OF RANGE CONTROL—Tune the receiver to the strongest station in the area in which the receiver will be used. While observing the picture and listening to the sound, turn the control clockwise until signs of overloading (buzz in sound, washed-out picture, sync instability) appear. Then turn the control a few degrees counter-clockwise from the point at which overloading occurs. (The stronger the signal input, the more counter-clockwise this setting will be.) In areas where the strongest signal does not exceed 1000 MV the setting will usually be maximum clockwise. With the control set correctly, the AGC will automatically adjust the bias on the R-F and I-F amplifiers so that the best possible signal to noise ratio (minimum snow) will be obtained for any signal input to the receiver.

SERVICE SUGGESTIONS

NO RASTER ON PICTURE TUBE — If raster cannot be obtained, check below for the possible causes:

1. No +B voltage. Check fusible resistor. Replace if defective. If fusible resistor continually burns out, check:
 - A. For short in +B.
 - B. Silicon rectifiers.
 - C. Check DC resistance of horizontal output transformer.
2. No high voltage. Check V-401, V-402, V-403 and V-404 tubes and circuits. If horizontal deflection circuits are operating as evidenced by the correct voltage (660V) measured on terminal number 1 of the horizontal output transformer, the trouble can

be isolated to the high voltage rectifier circuit. Either the high voltage winding to the V-402 plate and the V-403 plate is open or pix tube elements shorted internally.

3. Defective picture tube Cathode return circuit open.

HORIZONTAL DEFLECTION ONLY — If only horizontal deflection is obtained as evidenced by a straight line across the face of the picture tube, it can be caused by the following:

1. V-301A & B or V-302 inoperative. Check socket voltages.
2. Vertical output transformer open or shorted.
3. Yoke vertical coils open or shorted.
4. Vertical hold, height or linearity controls may be defective.

POOR VERTICAL LINEARITY — If adjustment of the height and linearity controls will not correct this condition, any of the following may be the cause:

1. Check variable resistors R-315 and R-317.
2. Vertical output transformer defective.
3. V-301A & B or V-302 defective, check voltages.
4. Excess leakage or incorrect value of capacitors C-306, C-308, C-309 or open or incorrect value of resistors R-306, R-307 and R-310.
5. Low plate voltages. Check power supply.
6. Vertical deflection coils defective.

POOR HORIZONTAL LINEARITY

1. Check or replace V-402 & V-404.
2. Check capacitors C-413, C-417 and C-421 for defects.
3. Horizontal deflection coils defective.
4. Check horizontal drive setting.

WRINKLES ON LEFT SIDE OF RASTER — This condition can be caused by:

1. Defective yoke:
2. V-404 defective.
3. R-416 defective.

I-F ALIGNMENT PROCEDURE

SIGNAL INFORMATION AND TEST EQUIPMENT

Cathode - Ray Oscilloscope with good low frequency response and an input calibrating source.

40 MC Sweep Generator

V.T.V.M.

Bias supply adjustable from 2 to 10 volts DC.

CRYSTAL MARKERS REQUIRED

| | |
|----------|----------|
| 41.25 mc | 45.3 mc |
| 42.4 mc | 45.75 mc |
| 42.8 mc | 47.25 mc |
| 44.0 mc | |

CONDITIONS

Line voltage—117 V.—60 cps.

Tuner set to Channel 13 position.

Contrast maximum.

Range control fully counter clock-wise.

ALIGNMENT PROCEDURE—(continued)

OUTPUT STAGE ALIGNMENT

1. Connect oscilloscope to top of 2nd detector load resistor (T.P."B").
2. Connect sweep generator to grid of third I-F tube (V-203).
3. Adjust sweep output to give 4 volts peak to peak on oscilloscope.
4. Adjust bottom (primary) and top (secondary) of 3rd I-F transformer (T202) for maximum height and symmetry at 44.0 mc. See Figure 3.

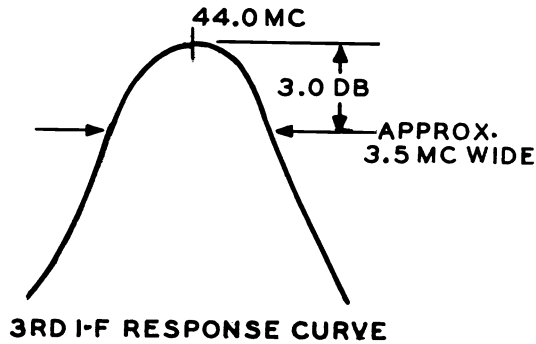

Fig. 3

PIX I-F ALIGNMENT—When the output stage is aligned:

1. Connect sweep generator to grid of 1st I-F tube (V-201).
2. Connect bias supply to AGC terminal (TP-"A") and adjust sweep output to give 4 volts peak to peak on oscilloscope.
3. Adjust first I-F transformer (T200 bottom) for maximum height of 42.8 mc marker.
4. Adjust 47.25 mc (T200 top) I-F trap for minimum height of 47.25 mc marker.
5. Adjust 2nd I-F transformer (T201 bottom) for maximum height of 45.3 mc marker.
6. Adjust 41.25 mc (T201 top) I-F trap for minimum height of 41.25 mc marker.

If necessary, re-adjust 3rd I-F transformer primary (T202 bottom) for symmetry of the top of curve.

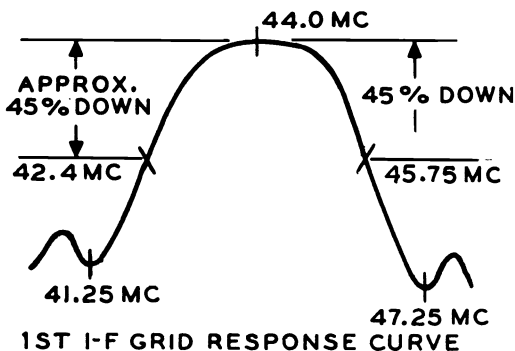

Fig. 4

After these adjustments are made, re-check the peak to peak output on the oscilloscope.

Re-set sweep output if necessary. If the shape of the curve is not as shown in Figure 4, it will be necessary to re-touch the adjustments. A small fraction of a turn is all that is necessary if the I-F strip is operating correctly. The 44.0 mc transformer (3rd I-F — T202) controls the symmetry of the top.

The 45.3 mc transformer (2nd I-F — T201) controls the height of the 45.75 mc marker. The 42.8 transformer (1st I-F—T200) controls the height of the 42.4 mc marker.

OVERALL I-F ALIGNMENT

1. Connect output of sweep generator to tuner mixer grid (I-F test point on tuner) and re-adjust output to give 4 Volts peak to peak.
2. Adjust converter plate coil (L-9) and I-F input coil (L200) to give response shown in Figure 5.

Several adjustments back and forth between the converter plate coil and 1st I-F input coil will be required to obtain the response shown in Figure 5.

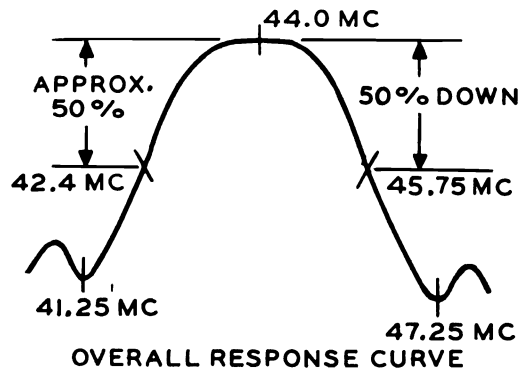

Fig. 5

VIDEO

With 4.5 Mc unmodulated signal into grid of the video amplifier tube and VTVM on picture tube cathode, tune 4.5 Mc trap for minimum response. VTVM on 0-10 V AC scale. This adjustment can also be made while observing a picture from a station. Tune trap for least 4.5 Mc beat (grainy appearance) in picture.

AUDIO

1. Tune in a high signal level TV station and adjust the Quadrature Coil (L-101) and the Buzz Control (R-100) for maximum undistorted sound and minimum buzz.
2. Reduce signal strength at antenna terminals by means of an attenuator or similar device until a "hiss" accompanies the sound.
3. Adjust Sound Take-Off Coil for maximum sound.
4. If "hiss" strength disappears during step 3, further reduce signal strength.

VOLUME TV-24, ADDITIONAL 1965 TELEVISION

MONTGOMERY WARD

Models WG-4515A, WG-4545A, WG-4555A

Service Information, Continued

**25A1246-001 VHF TUNER
STANDARD KOLLSMAN PART NO. ARS-034**

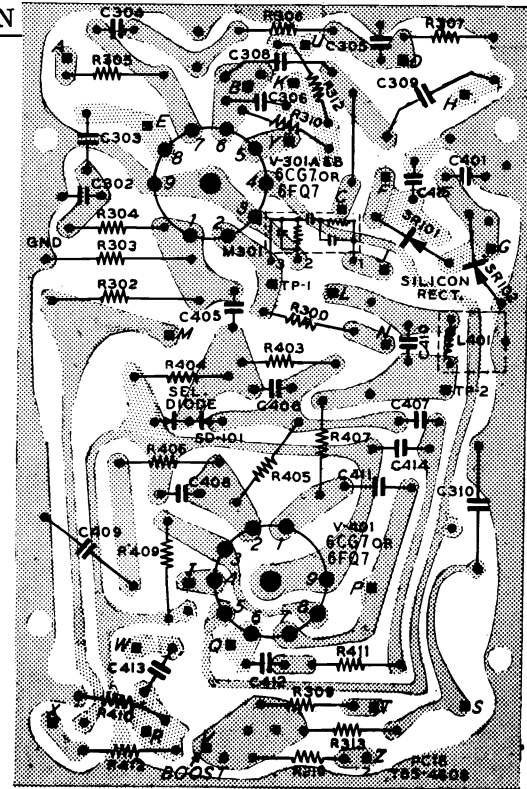
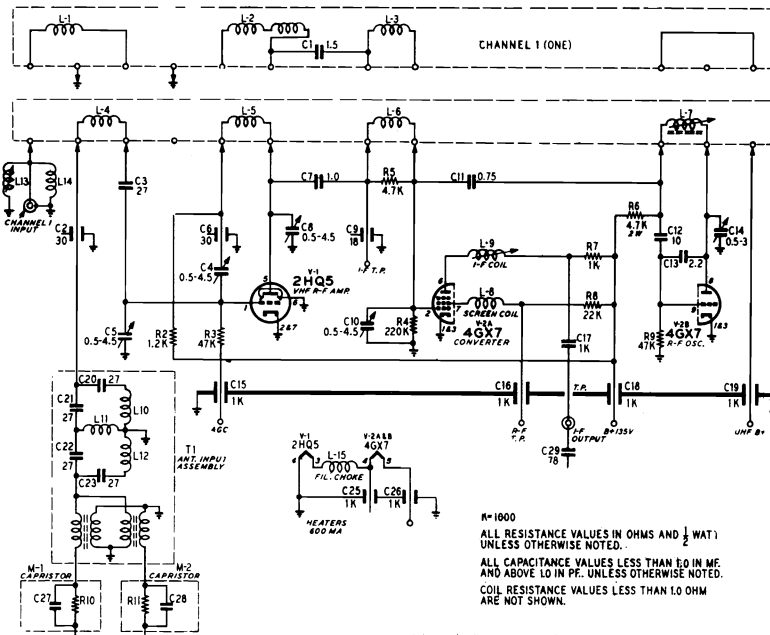

38A2973-000 PRINTED CIRCUIT BOARD ASSEMBLY (SWEEP)

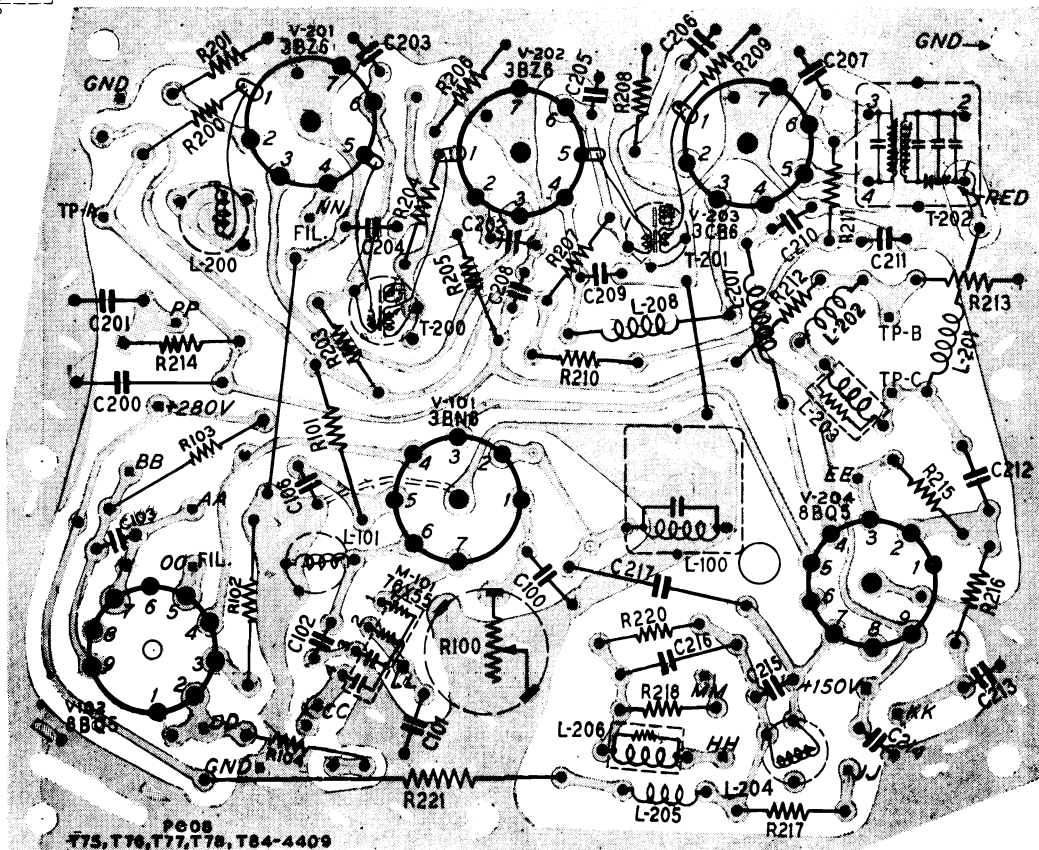

38A2722-000 PRINTED CIRCUIT BOARD ASSEMBLY (I-F)

MOTOROLA CHASSIS VTS-454, WTS-454

MODEL BREAKDOWN CHART

| MODEL | CHASSIS | VHF TUNER | UHF TUNER | CRT |
|------------------|---------|-----------|------------------------|--------|
| 12BP70AA | VTS-454 | CMTT-376Y | TT-617 or TT-622 | 12BGP4 |
| 12BP71AL,N,R & Y | WTS-454 | CMTT-376Y | TT-617 or TT-622 | 12BGP4 |

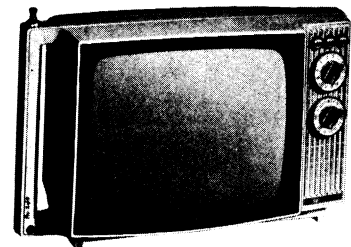

MODEL 12BP71

The receivers in this manual employ 2 horizontally mounted chassis containing 11 tubes; 5 multi-purpose tubes, two of which are of the compactron type and a 110⁺, 12" shell-bond picture tube. The main chassis (lower) is of the etched board type and contains the major portion of the tubes and circuitry. The upper chassis contains the heavy components such as the vertical and horizontal transformers, filter choke, etc.

FOCUSING ADJUSTMENT

To provide for differences in the picture tube gun structure, a focus adjustment is provided by three (3) lugs located on the chassis. They provide a ground potential point, a B+ voltage point and a bootstrap voltage point. Connect the blue lead from the picture tube socket to the lug which provides the best over-all focus, center to edge of screen.

FINE TUNING ADJUSTMENT

The low and high band of the VHF tuner may be adjusted externally from the front of the receiver (see Figure #1). The low band adjustment is made with the channel #6 oscillator adjustment screw located to the right of the tuning shaft (see Figure #1). The high band adjustment is made with the channel #13 oscillator adjustment screw located to the left of the tuning shaft.

Individual oscillator adjustments are provided and are available with the tuner removed from the tuner mounting bracket. If individual oscillator adjustment is necessary, the highest available channel should be adjusted first and the remaining available channels should be adjusted in descending order.

PICTURE TUBE REPLACEMENT

Use extreme care in handling the picture tube as rough handling may cause it to implode due to atmos-

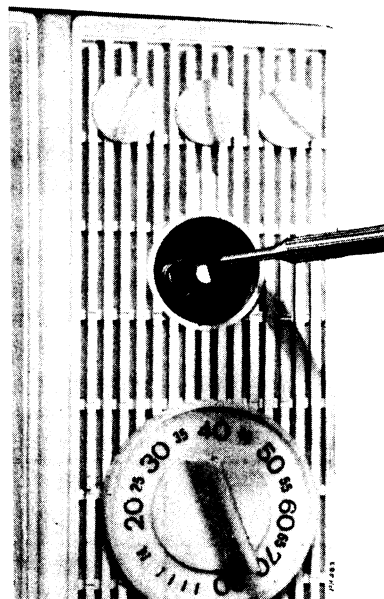

FIGURE 1. OSCILLATOR ADJUSTMENT

pheric pressure. Do not nick or scratch glass or subject it to any undue pressure in removal or installation. Use goggles and heavy gloves for protection.

By removing the upper and lower chassis retaining screws (6), the two chassis may be positioned as shown in Figure #2 for CRT removal.

CHASSIS REMOVAL

The upper chassis is retained by two (2) screws and a bottom support bracket (see Figure #4).

The lower chassis is retained by 3 screws accessible from the bottom of the receiver.

CONTROL BRACKET REMOVAL

To service tuners or front controls, remove the four (4) control bracket retaining screws (see Figure #3).

Position as shown in Figure #5 which provides accessibility to the three front controls and UHF tuner removal.

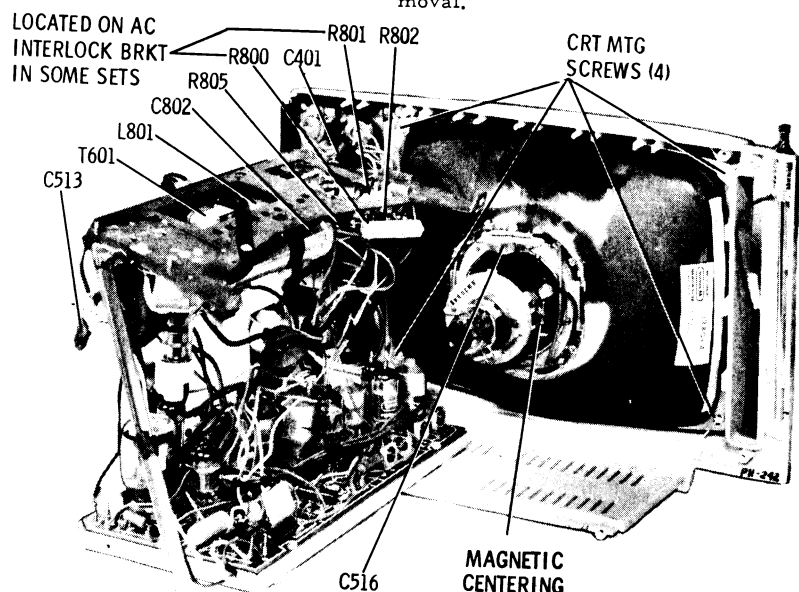

FIGURE 2. CHASSIS POSITIONED FOR CRT REMOVAL

VOLUME TV-24, ADDITIONAL 1965 TELEVISION SERVICING INFORMATION

MOTOROLA Chassis VTS-454, WTS-454 Service Information, Continued

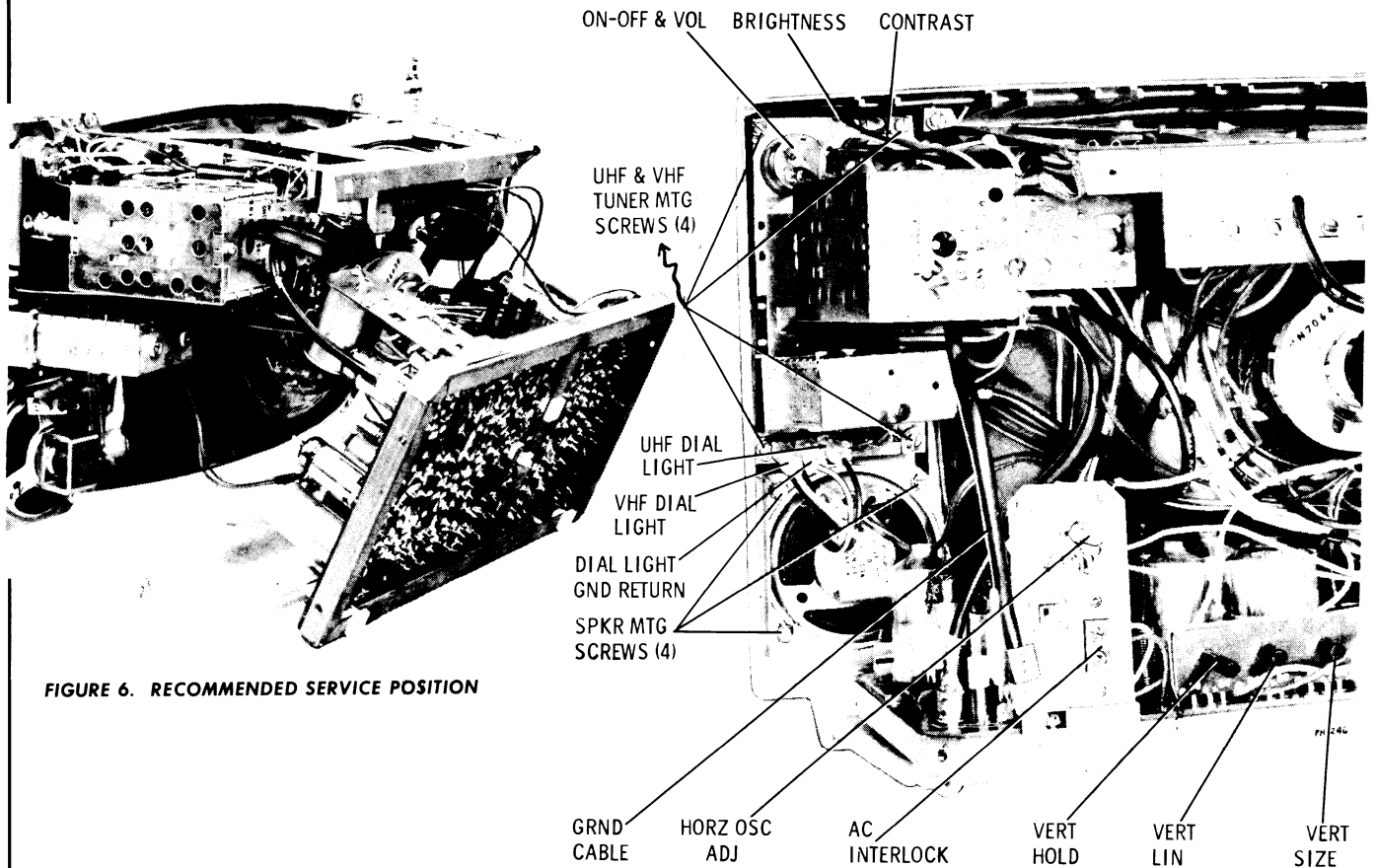

FIGURE 6. RECOMMENDED SERVICE POSITION

FIGURE 3. TUNER, CONTROL BRACKET & SPEAKER REMOVAL

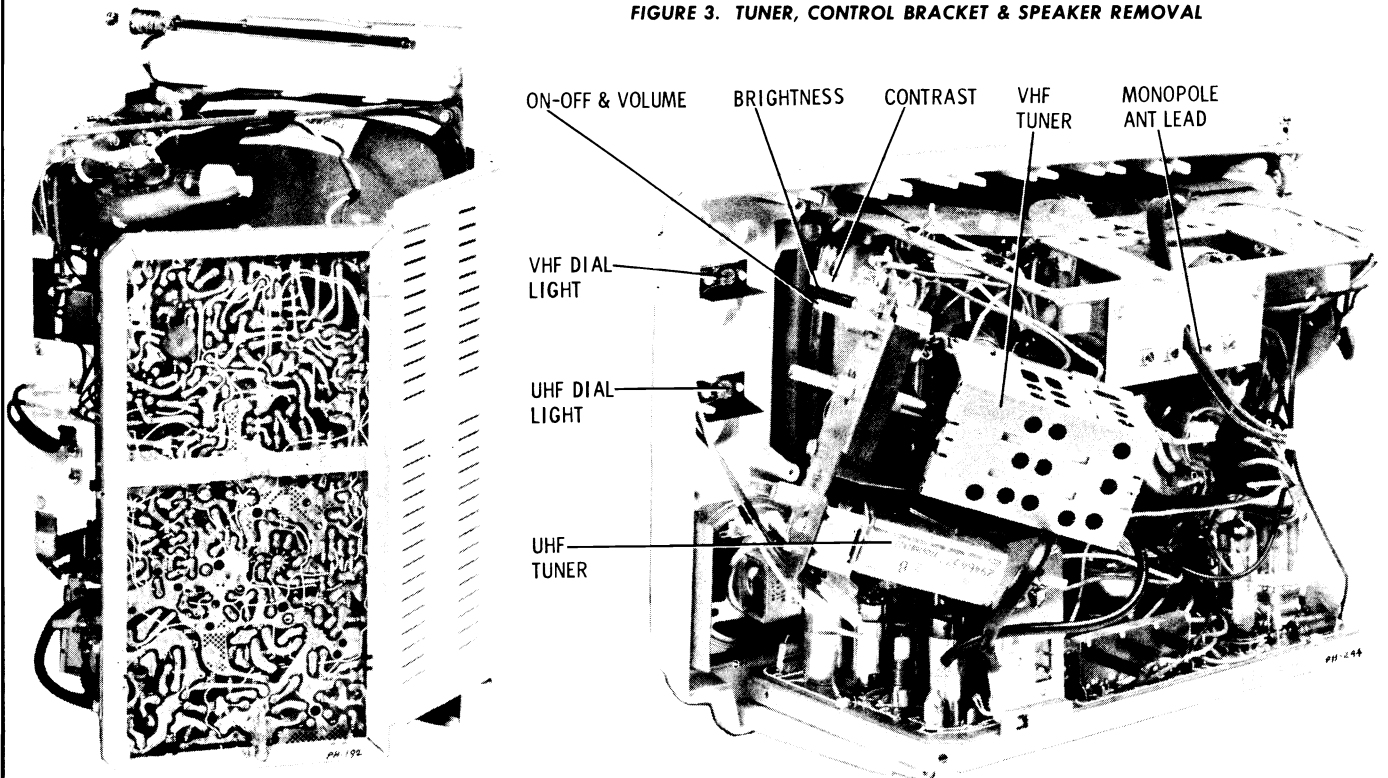
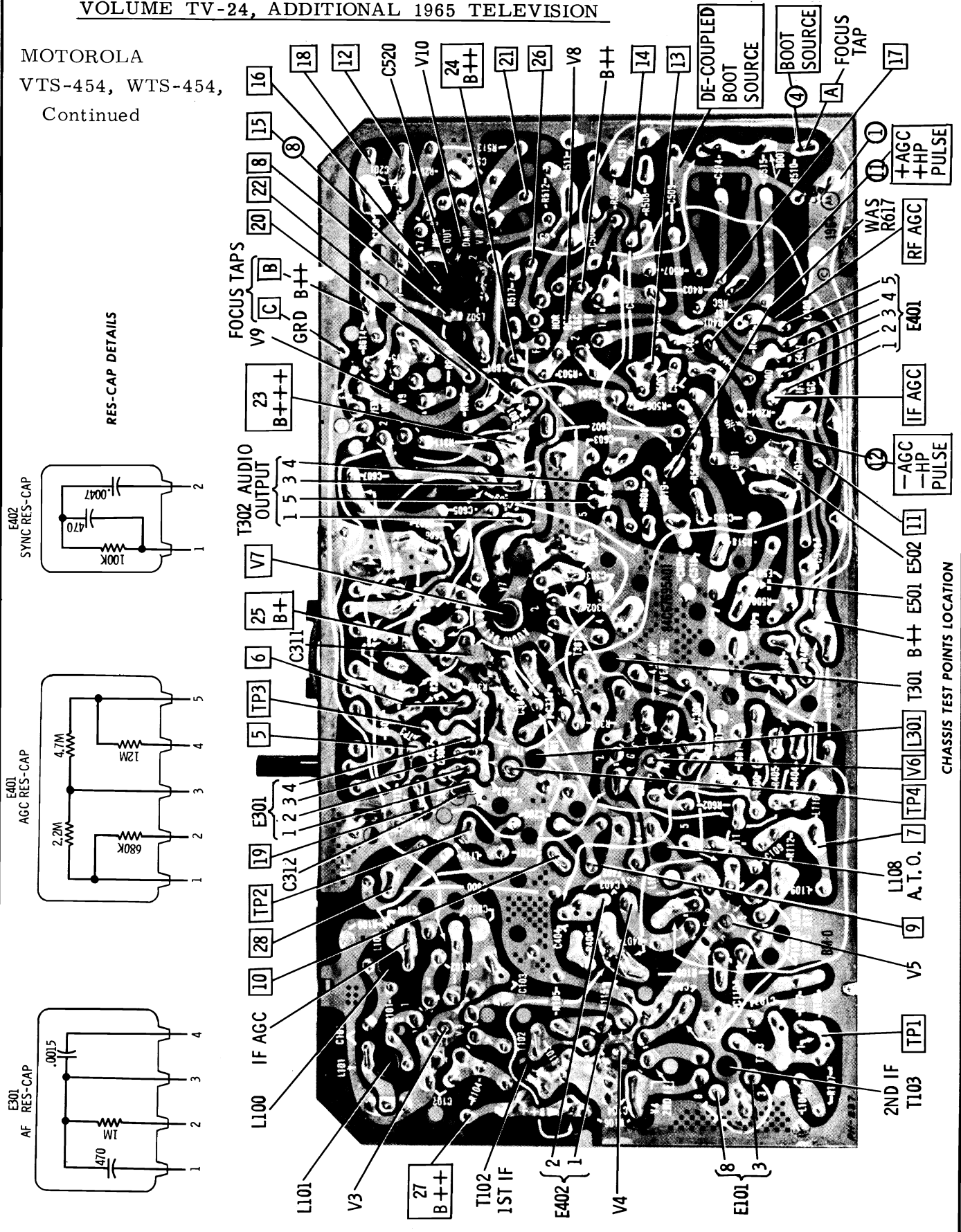

FIGURE 7. RECOMMENDED SERVICE POSITION

FIGURE 5. CONTROL BRACKET REMOVED FOR CONTROLS, AND TUNER SERVICING

VOLUME TV-24, ADDITIONAL 1965 TELEVISION

MOTOROLA
VTS-454, WTS-454,
Continued



RES-CAP DETAILS

CHASSIS TEST POINTS LOCATION

VOLUME TV-24, ADDITIONAL 1965 TELEVISION SERVICING INFORMATION

MOTOROLA Chassis VTS-454, WTS-454 Alignment Information

ALIGNMENT PROCEDURE

Pre-Alignment Instructions

Before alignment of the video I.F. section is attempted, it is advisable to thoroughly check the system. If alignment is attempted on an I. F. section in which a faulty component exists, successful alignment will probably be impossible and the entire procedure will have to be repeated when the real cause of the trouble is corrected. Preliminary tests of the system should include voltage and resistance measurements, routine checks for bad soldering connections and visual inspection of the circuits for overheated components as well as for obvious wiring defects.

VIDEO IF & MIXER ALIGNMENT

Pre-Alignment Steps

1. Maintain line voltage at 120 with variac.
2. Remove the two yellow leads from yoke to eliminate RF interference radiation.
3. Disable local oscillator. Ground oscillator grid of mixer-oscillator tube with a piece of bare wire to the tube shield thru hole provided in shield.
4. Apply the negative lead of a 6.0 volt bias supply to I.F. AGC buss, pin #1 of AGC res-cap, E-401, and positive lead to chassis ground.
5. Connect a 750 ohm, 60 watt voltage normalizing resistor from B++ to chassis.

6. Set the contrast control at minimum (extreme counter-clockwise position).
7. Short across tuner input terminals.
8. Maintain 2 volts peak-to-peak at the grid of video amp except when specific values are given in the procedure chart.
9. Refer to "Chassis Alignment Detail" for component and test point locations.

NOTE: To reduce the possibility of inter-action between the two tuning cores in a double tuned transformer or coil, each core should be adjusted for optimum response in the tuning position nearest its respective end of the coil form.

VIDEO IF & MIXER ALIGNMENT PROCEDURE

| STEP | SWEEP GENERATOR AND MARKER | INDICATOR | ADJUST | ADJUST FOR AND/OR REMARKS |
|------|---|---|--|---|
| 1. | To grid of 2nd I.F. thru .001mf capacitor. Set sweep to approx 44Mc, markers as required. | Scope to grid of video amp thru 47K ohm resistor. | Both cores of 2nd I.F. transformer (T-103). | Equal peaks and marker placement as shown in curve #1. |
| 2. | To grid (pin #1) of 1st I.F. amp thru .001mf capacitor. Set sweep to 44Mc, markers as required. | Same as Step #1. | 1st I. F. transformer (T-102). | Symmetrical curve and proper 45.75Mc marker placement. See curve #2. The 41.75Mc marker should fall between the 10% to 60% of curve as shown. |
| 3. | To mixer T. P. (M) thru .001mf capacitor. Set sweep to 44Mc, markers as required. | Same as Step #1. | 47.25Mc trap (L-100). | Minimum response at proper trap frequency. See curve #3. NOTE: Temporary removal of bias and an increase of generator output may be required to see trap clearly. |
| 4. | Same as Step #3. | Same as Step #1. | Mixer plate coil (L-1 on tuner and 1st I.F. grid coil (L-101). | To do in curve #4. The mixer coil affects the low side and the grid coil affects the high side. Tune coils simultaneously for proper tuning and band-width consistent with maximum gain. If necessary, the 1st I.F. transformer can be touched-up to obtain proper response as shown in curve #4. |

SOUND ALIGNMENT (STATION SIGNAL METHOD)

The sound system used in this receiver consists of an audio I.F. amplifier stage, a quadrature grid detector and an output stage. Since this type of sound system is extremely sensitive, relatively small input signal voltage will cause grid current to flow in both the I.F. amplifier and the detector stages. Grid

current through the tuned coils will load them down making the adjustment extremely broad and alignment impossible. For this reason, it is necessary to use a very weak signal when aligning the driver and the detector input coils. Actually, the signal should be well down into the noise level for proper tuning action.

Preliminary Steps

1. Tune in a strong TV station.
2. Adjust all controls for normal picture and sound.
3. Refer to "Chassis Alignment Detail" for coil and test point locations.

VOLUME TV-24, ADDITIONAL 1965 TELEVISION SERVICING INFORMATION

MOTOROLA Chassis VTS-454, WTS-454 Alignment Data, Continued

SOUND ALIGNMENT PROCEDURE

| STEP | STATION | INDICATOR | ADJUST | ADJUST FOR AND/OR REMARKS |
|------|----------------|---|---------------------------|---|
| 1. | Strong signal. | VTVM to point T. P. 4 on quad. coil L-301. (See schematic diagram.) | L-301 (quad. coil). | Maximum deflection (coarse adjustment) of two possible maximum tuning points, use that giving largest voltage reading.* |
| 2. | " | Listening test. | " | Maximum sound with minimum distortion (fine adjustment). |
| 3. | Weak signal. | " | T-301 (inter-stage coil). | Maximum sound with minimum distortion (maintain hiss level).** |
| 4. | " | " | L-108 (take-off coil). | Maximum sound with minimum distortion. |

If sound is not clear at this point, repeat the above procedure as necessary.

*The purpose of the top pre-set core is to enable the adjustable core to make the tuning range required while reducing the physical length. If the pre-set core should be mis-adjusted by previous service work, merely re-set near top end of coil and tune for maximum.

**The signal must be weakened considerably either by disconnecting one side of the antenna lead or connecting low value resistors across the antenna terminals until a pronounced hiss appears in the sound. The hiss level must be maintained for proper alignment.

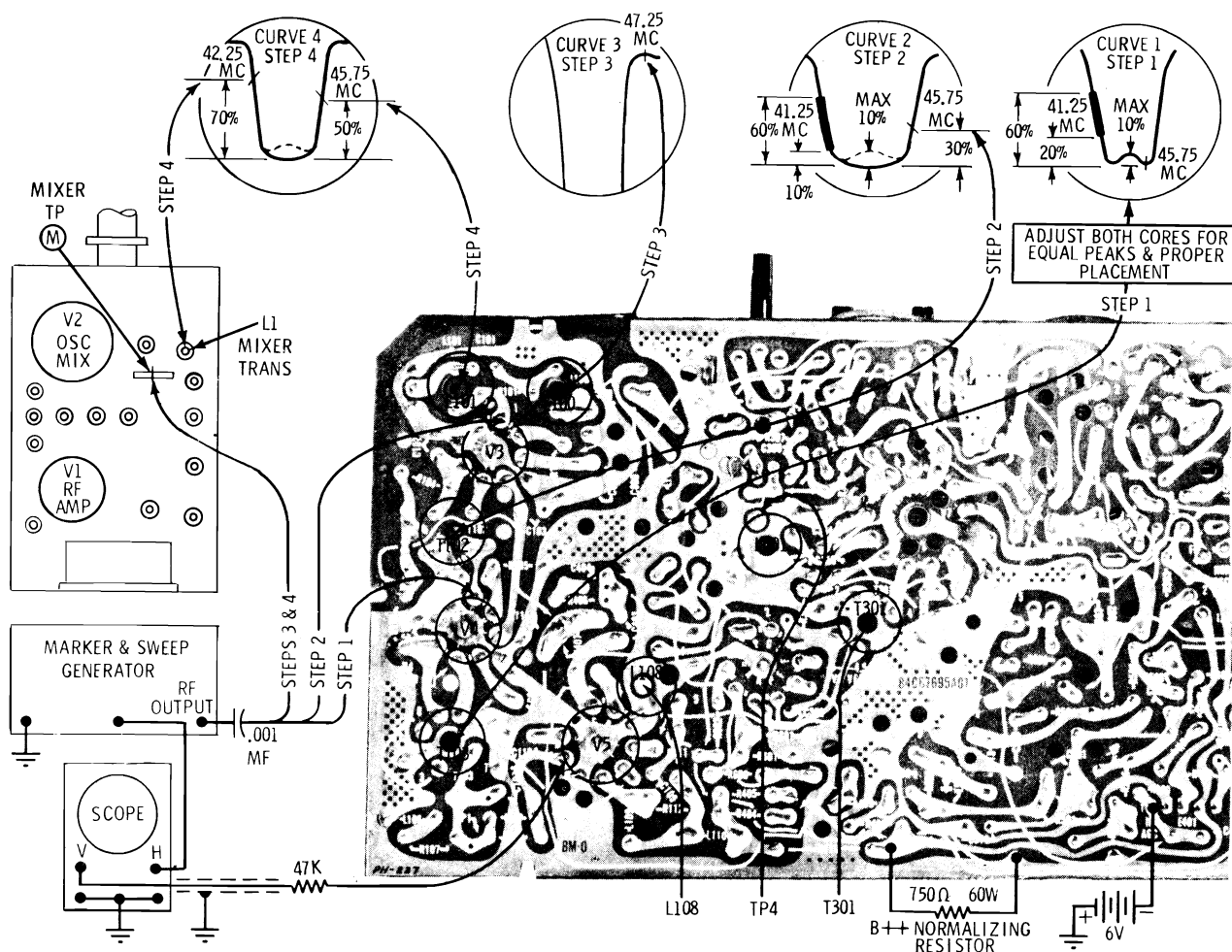

CHASSIS ALIGNMENT DETAIL

VOLUME TV-24, ADDITIONAL 1965 TELEVISION

MOTOROLA Chassis VTS-454, WTS-454 Diagram

NOTES:

VOLTAGE MEASUREMENTS

1. TAKEN FROM POINT INDICATED TO CHASSIS WITH A VTVM. $\pm 2\%$
2. LINE VOLTAGE MAINTAINED AT 120V AC.
3. TAKEN WITH CONTRAST CONTROL AT MINIMUM AND ALL OTHER CONTROLS IN NORMAL OPERATING POSITION WITH NO SIGNAL INPUT.
4. TUNER ON CHANNEL 13 OR CHANNEL OF LEAST NOISE WITH ANTENNA TERMINALS SHORTED.

WAVEFORM MEASUREMENTS

1. TAKEN FROM POINT INDICATED TO CHASSIS WITH A WIDE-BAND OSCILLOSCOPE.

2. OSCILLOSCOPE SYNCED NEAR SWEEP RATE INDICATED.
3. TAKEN WITH STRONG SIGNAL, CONTRAST CONTROL AT MAXIMUM; ALL OTHER CONTROLS IN NORMAL OPERATING POSITION.

* INDICATES VOLTAGE VARIES WITH CONTROL SETTINGS.
 ** INDICATES SPECIAL COMPONENTS.
 UNLESS OTHERWISE SPECIFIED: CAPACITORS ARE DISC CERAMIC 500V DC, TOLERANCE & CHARACTERISTIC AS NOTED; IF TOLERANCE IS NOT GIVEN CAPACITORS ARE 40V (GUARANTEED MIN. VALUE) TYPE. TUBULAR CAPACITORS ARE 20% 400V DC. DECIMAL VALUES IN MF ALL OTHERS IN PP. RESISTORS ARE ALL 10% 1/2 WATT UNLESS SPECIFIED.

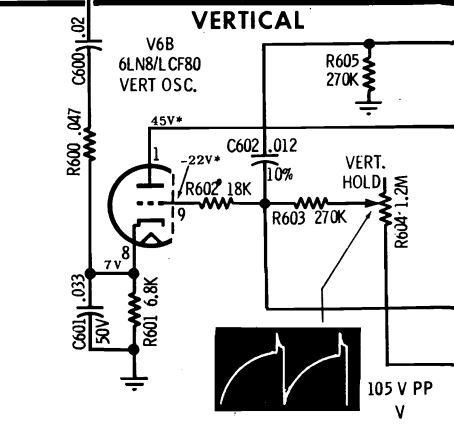
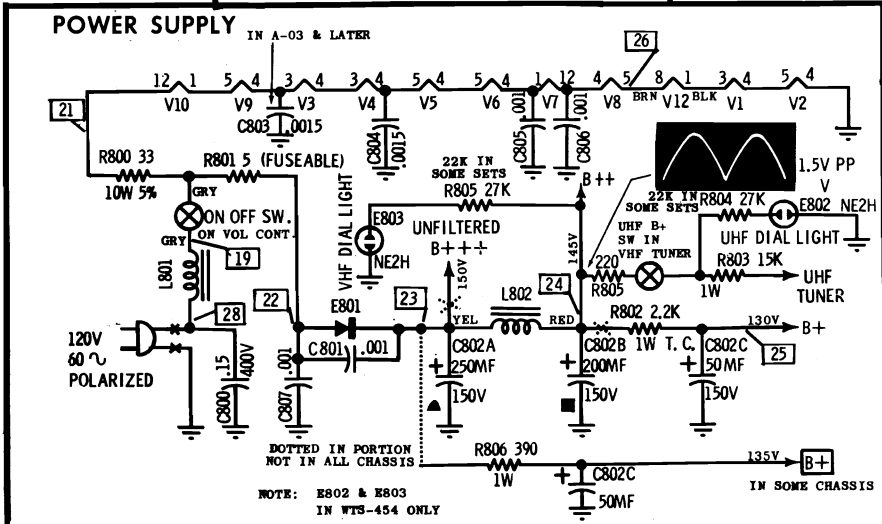
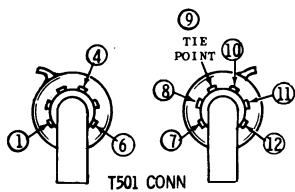
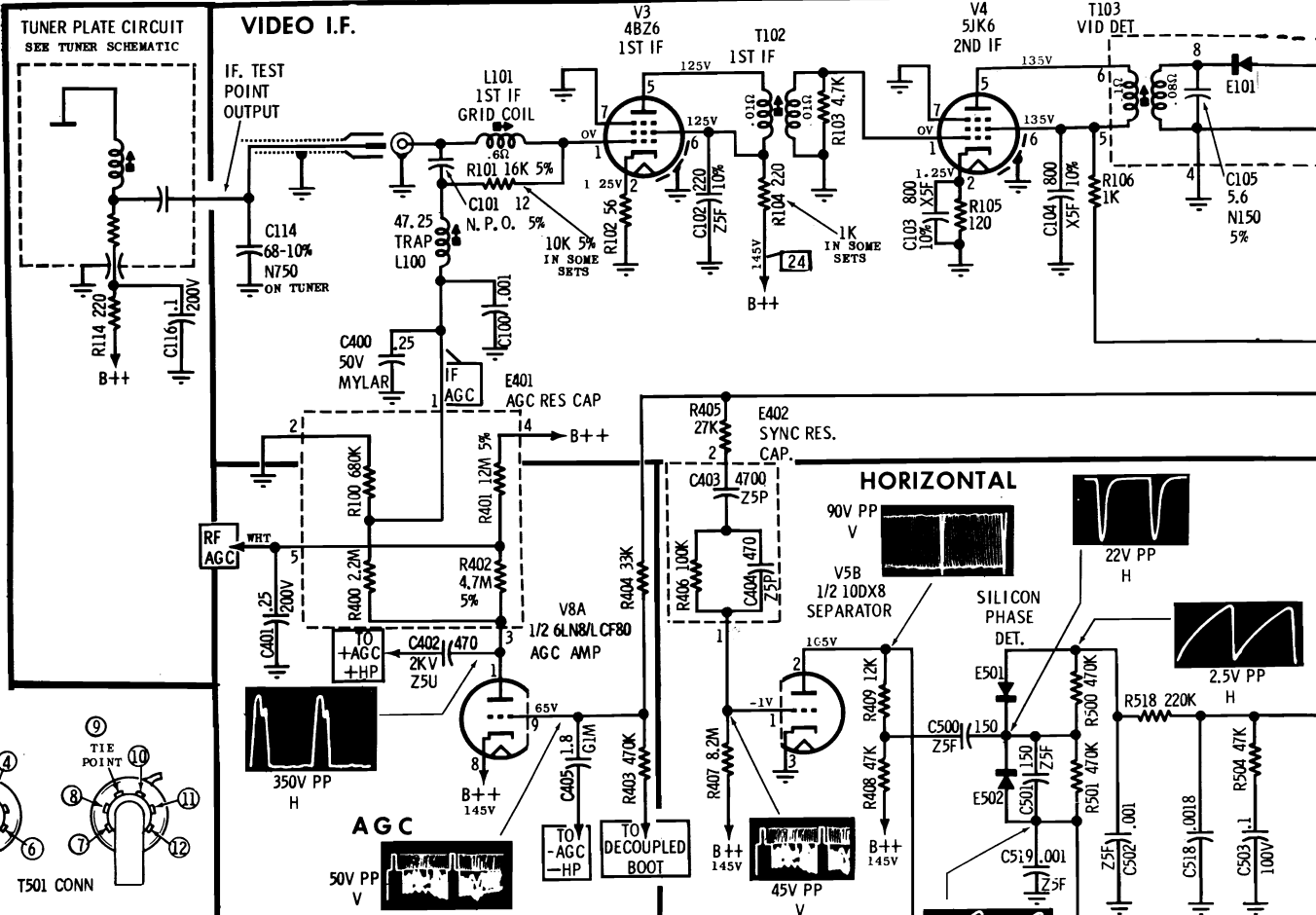
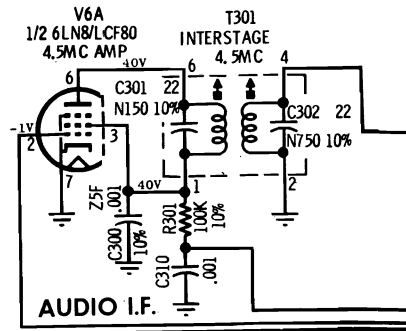

MOTOROLA
Chassis VTS-454,
WTS-454, Continued

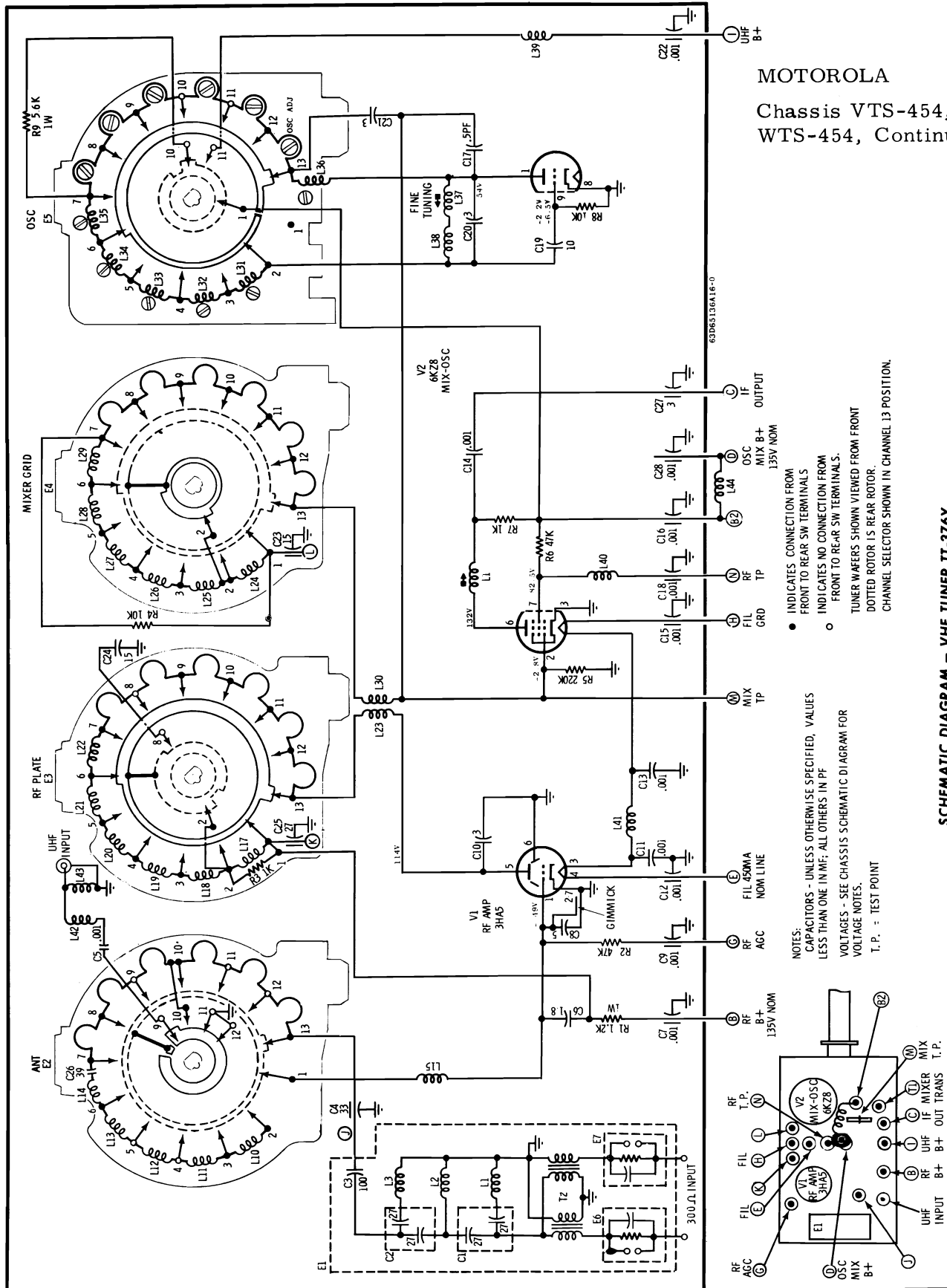

- INDICATES CONNECTION FROM FRONT TO REAR SW TERMINALS
- INDICATES NO CONNECTION FROM FRONT TO REAR SW TERMINALS.
- TUNER WAFERS SHOWN VIEWED FROM FRONT
- DOTTED ROTOR IS REAR ROTOR.
- CHANNEL SELECTOR SHOWN IN CHANNEL 13 POSITION.

NOTES:
CAPACITORS - UNLESS OTHERWISE SPECIFIED, VALUES LESS THAN ONE IN MF, ALL OTHERS IN PF
VOLTAGES - SEE CHASSIS SCHEMATIC DIAGRAM FOR VOLTAGE NOTES.
T. P. : TEST POINT

SCHEMATIC DIAGRAM - VHF TUNER TT-376Y

VOLUME TV-24, ADDITIONAL 1965 TELEVISION SERVICING INFORMATION

CHASSIS

MOTOROLA

TDTS-586Y, WNDTS-586Y, WZDTS-586Y, ZDTS-586Y

MODELS 19BP101A, 103A, 104A, 105A

(Service material on pages 73 through 78)

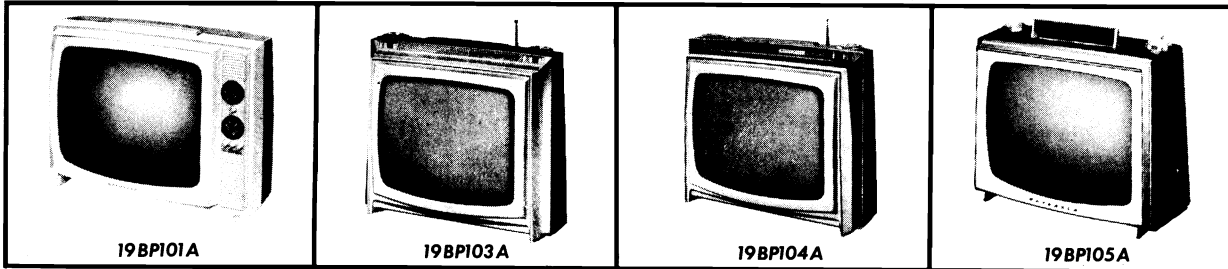

MODEL BREAKDOWN CHART

| MODEL | CHASSIS | VHF TUNER | UHF TUNER | CRT |
|---------------|-------------|------------|-----------|------------------|
| 19BP101AA | TDTS-586Y | SCMTT-365Y | ZTT-600 | 19CHP4 |
| 19BP101AA | TDTS-586Y-2 | SCMTT-365Y | ZTT-600SP | 19CHP4 |
| 19BP103AN | ZDTS-586Y | SCMTT-365Y | ZTT-600 | 19DSP4 or 19EFP4 |
| 19BP104AN,R | WZDTS-586Y | SCMTT-365Y | ZTT-600 | 19DSP4 or 19EFP4 |
| 19BP105AW,C,T | WNDTS-586Y | SCMTT-365Y | TT-609 | 19DSP4 or 19EFP4 |

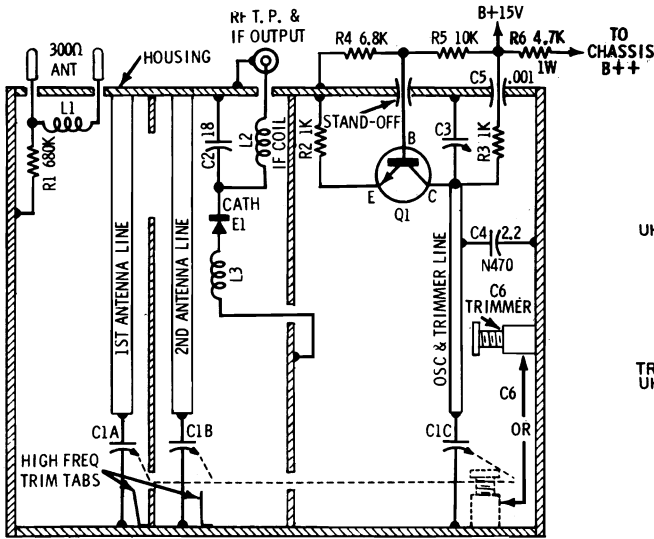

**UHF TUNER SCHEMATIC
DIAGRAM - ZTT-600SP**

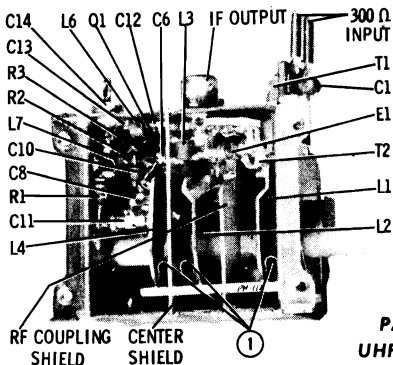

**PARTS LOCATION
UHF TUNER - TT-609**

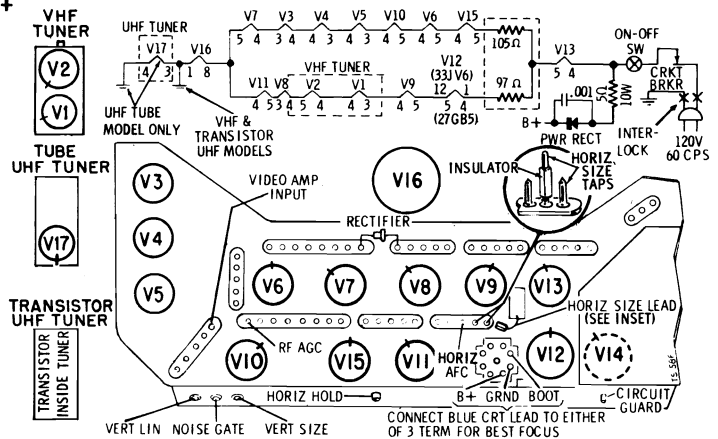

| REF. NO. | TUBE TYPE | FUNCTION | REF. NO. | TUBE TYPE | FUNCTION |
|----------|------------|----------------------|----------|--------------|----------------------------------|
| V1 | 4GK5 | RF AMP (TT312 & 365) | V10 | 9A8/PCF80 | NOISE INV & AGC AMP |
| | 4HA5 | RF AMP (TT361) | V11 | 9A8/PCF80 | SYNC CLIP & HORIZ OSC |
| V2 | 9A8 | MIXER-OSC (TT365) | V12 | *33U V6 | HORIZ OUTPUT |
| | 7HG8 | MIXER-OSC (TT312) | | *27GB5/PL500 | HORIZ OUTPUT |
| | 9KZ8 | MIXER-OSC (TT361) | V13 | 12BE3 | DAMPER |
| V3 | 6BZ6A | 1ST IF AMP | V14 | *3A3/3AW3 | HV RECT |
| V4 | 6BZ6 | 2ND IF AMP | | *1S2 | HV RECT |
| V5 | 6DK6 | 3RD IF AMP | V15 | 15CW5/PL84 | VERT OUTPUT |
| V6 | 16CK6 | VIDEO AMP | V16 | 19CHP4 | PICT TUBE |
| V7 | 9A8/PCF80 | SOUND IF & VERT OSC | | *19EFP4/ | PICT TUBE |
| V8 | 6DT6 | AUDIO DET | | *19DSP4 | PICT TUBE |
| V9 | 15CW5/PL84 | AUDIO OUTPUT | V17 | 2AF4/2DZ4 | UHF OSC (TRANSISTOR SOME MODELS) |

* REPLACE WITH SAME TYPE AS ORIGINALLY IN SET

TUBE LOCATION & COMPLEMENT

VOLUME TV-24, ADDITIONAL 1965 TELEVISION SERVICING INFORMATION

MOTOROLA Chassis ++TS-586Y Alignment Information

ALIGNMENT FOR CHASSIS ZDTS, WZDTS-586-TDTS-586C-00, WNDTS-586C-00 & LATER

(FOR CHASSIS TDTS & WNDTS CODED PRIOR TO C-00 REFER TO
Most-Often-Needed 1964 TV manual, TV-22, page 77)

Pre-Alignment Instructions

Before alignment of the video I.F. section is attempted, it is advisable to thoroughly check the system. If alignment is attempted on an I.F. section in which a faulty component exists, successful alignment will probably be impossible and the entire procedure will have to be repeated when the real cause of the trouble is corrected. Preliminary tests of the system should include voltage and resistance measurements, routine checks for bad soldering connections and visual inspection of the circuits for overheated components as well as for obvious wiring defects.

VIDEO IF & MIXER ALIGNMENT

Pre-Alignment Steps

1. Maintain line voltage at 120 with variac.
2. Remove the yellow lead from yoke to eliminate RF interference radiation.
3. Disable local oscillator. Ground oscillator grid of mixer-oscillator tube with a piece of bare wire to the tube shield.
4. Apply the negative lead of a 6.0 volt bias supply to I.F. AGC buss and positive lead to chassis ground. See "Alignment Detail".
5. Connect a 750 ohm, 60 watt voltage normalizing resistor from B+ to chassis.
6. Set the contrast control at mini-

mum (extreme counter-clockwise position).

7. Short across tuner input terminals.

8. Maintain 2 volts peak-to-peak at the grid of video amp except when specific values are given in the procedure chart.

9. Refer to "Video I.F. And Sound Alignment Detail" for component and test point locations.

NOTE: To reduce the possibility of inter-action between the two tuning cores in a double tuned transformer or coil, each core should be adjusted for optimum response in the tuning position nearest its respective end of the coil form.

VIDEO IF & MIXER ALIGNMENT PROCEDURE

| STEP | SWEEP GENERATOR AND MARKER | INDICATOR | ADJUST | ADJUST FOR AND/OR REMARKS |
|------|--|---|---|--|
| 1. | To grid of 3rd I.F. thru .001mf capacitor. Set sweep to approximately 44Mc, markers as required. | Scope to grid of Video Amp thru 47K ohm resistor. | Both cores of 3rd I.F. transformer (T-103). | Equal peaks and marker placement as shown in curve #1. |
| 2. | To grid (pin #1) of 1st I.F. amp thru .001mf capacitor. Wrap a wire around grid pin of tube and connect generator to wire. Set sweep to 44Mc, markers as required. | Same as Step #1. | 1st I.F. transformer (T-101) - 2nd I.F. transformer (T-102). | Proper 42.25Mc marker placement. See curve #2. Proper 45.75Mc marker placement. See curve #2. NOTE: Mixer plate coil (L-1) may cause suck-out in I.F. response. Detune transformer if desired. |
| 3. | To mixer T. P. (M) thru .001mf capacitor. Set sweep to 44Mc, markers as required. | Same as Step #1. | 47.25Mc trap (L-101 bottom core). | Minimum response at proper trap frequency. See curve #3. NOTE: Temporary removal of bias and an increase of generator output may be required to see traps clearly. |
| 4. | Same as Step #3. | Same as Step #1. | Mixer plate coil (L-1 on tuner and 1st I.F. grid coil (L-103 - top core). | To obtain curve #4. The mixer coil affects the center peak and the grid coil affects the two outside peaks. Tune coils simultaneously for proper tuning and band-width consistent with maximum gain. If necessary, the 1st and 2nd I.F. transformers can be touched-up to obtain proper response as shown in curve #4. NOTE: The 41.25Mc marker must fall at the 90% level of this response curve or higher as shown in curve #4. If necessary, the 42.25Mc marker placement may deviate slightly to properly place the 41.25Mc marker. |

VOLUME TV-24, ADDITIONAL 1965 TELEVISION SERVICING INFORMATION

MOTOROLA TS-586B-02 SCHEMATIC DIAGRAM INCLUDES PDTs, WDTs & TDTs

VOLTAGE MEASUREMENTS

1. TAKEN FROM POINT INDICATED TO CHASSIS WITH A VTVM. $\pm 20\%$
2. LINE VOLTAGE MAINTAINED AT 120V AC.
3. VOLTAGES INDICATED BY AN ASTERISK WILL VARY WITH ASSOCIATED CONTROL SETTINGS.
4. TAKEN WITH CONTRAST CONTROL AT MINIMUM AND ALL OTHER CONTROLS IN NORMAL OPERATING POSITION WITH NO SIGNAL INPUT.
5. TUNER ON CHANNEL 13 OR CHANNEL OF LEAST NOISE WITH ANTENNA TERMINALS SHORTED.

WAVEFORM MEASUREMENTS

1. TAKEN FROM POINT INDICATED TO CHASSIS WITH A WIDE-BAND OSCILLOSCOPE.
2. OSCILLOSCOPE SYNCED NEAR SWEEP RATE INDICATED.
3. TAKEN WITH STRONG SIGNAL, CONTRAST CONTROL AT MAXIMUM, ALL OTHER CONTROLS IN NORMAL OPERATING POSITION.

CAPACITORS UNLESS OTHERWISE SPECIFIED, VALUES LESS THAN ONE IN MF; ALL OTHERS IN MMF.

** INDICATES SPECIAL COMPONENTS.

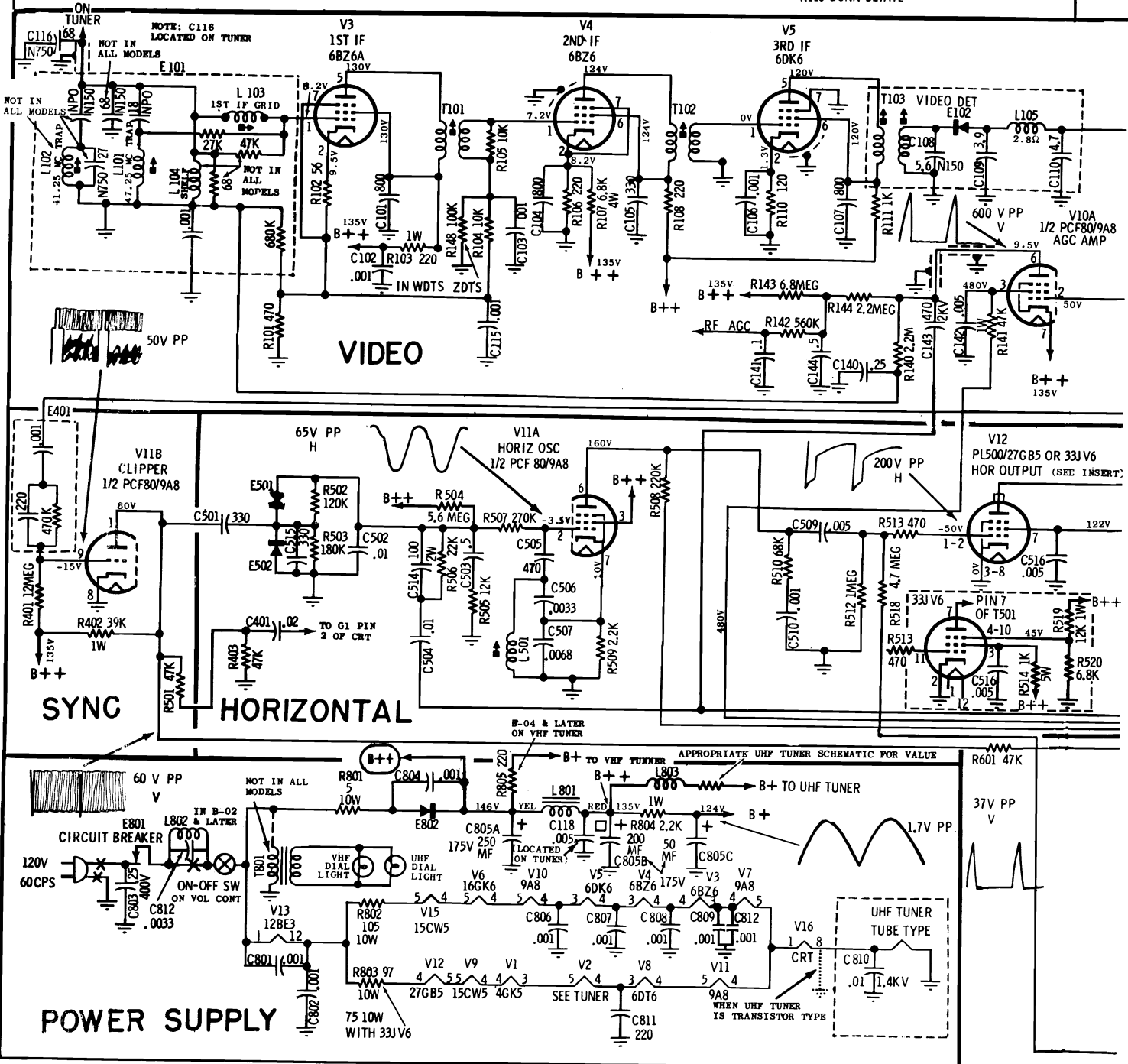
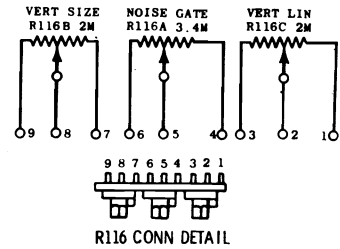
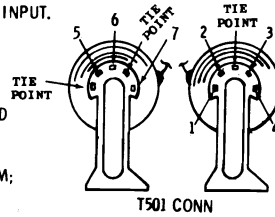

VOLUME TV-24, ADDITIONAL 1965 TELEVISION SERVICING INFORMATION

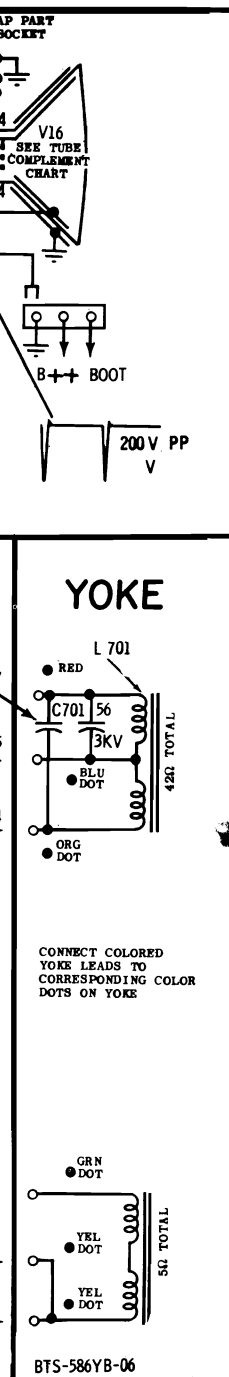
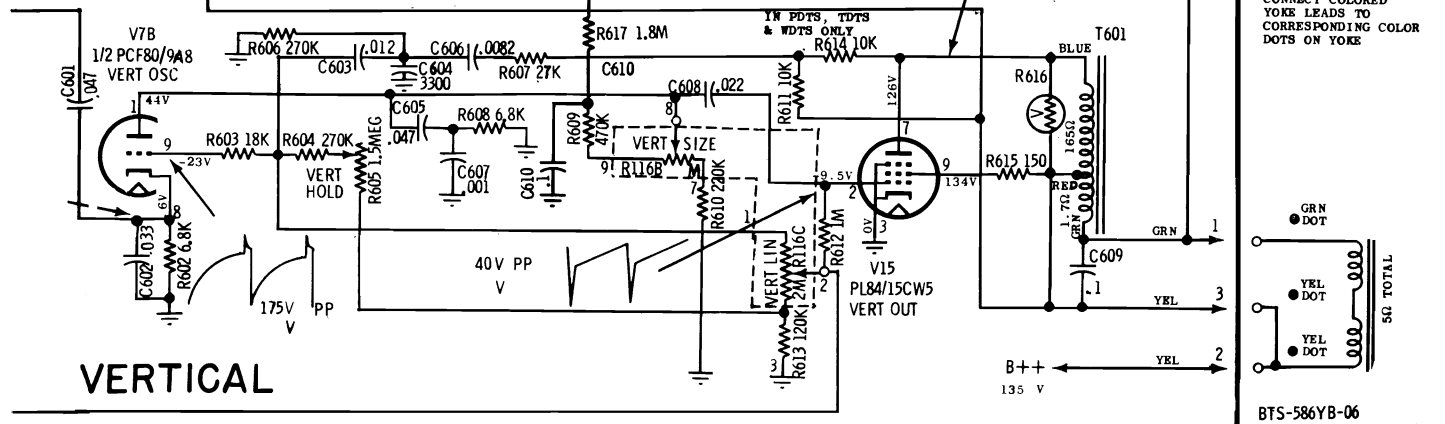
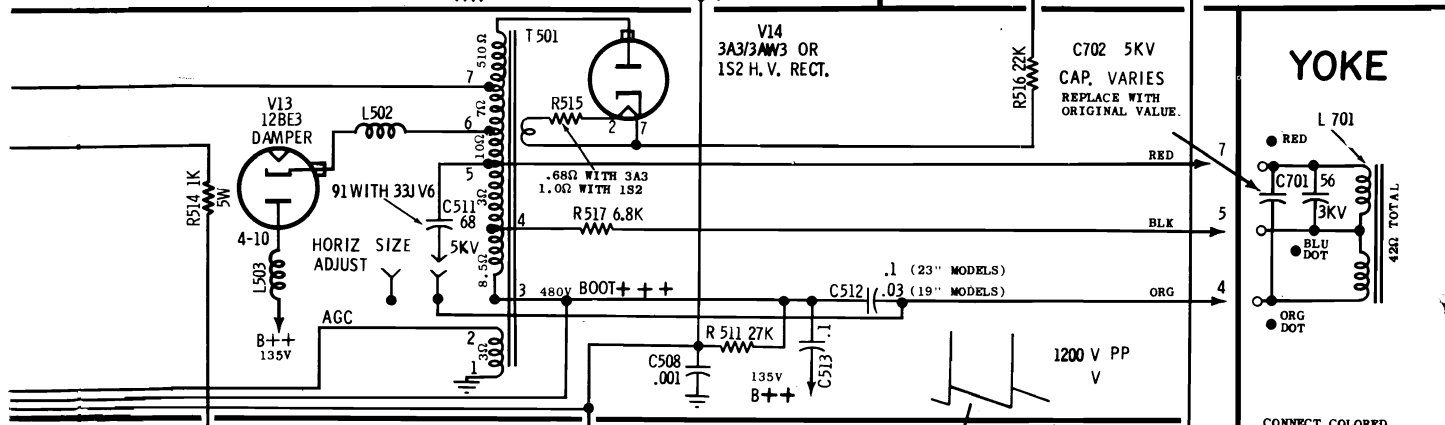
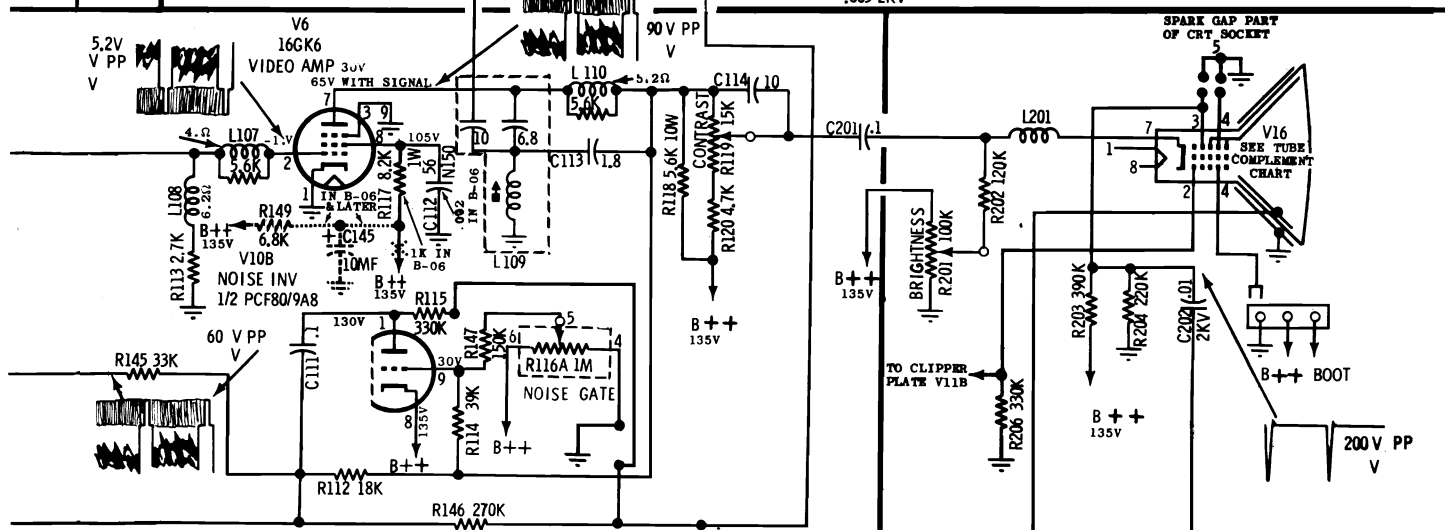
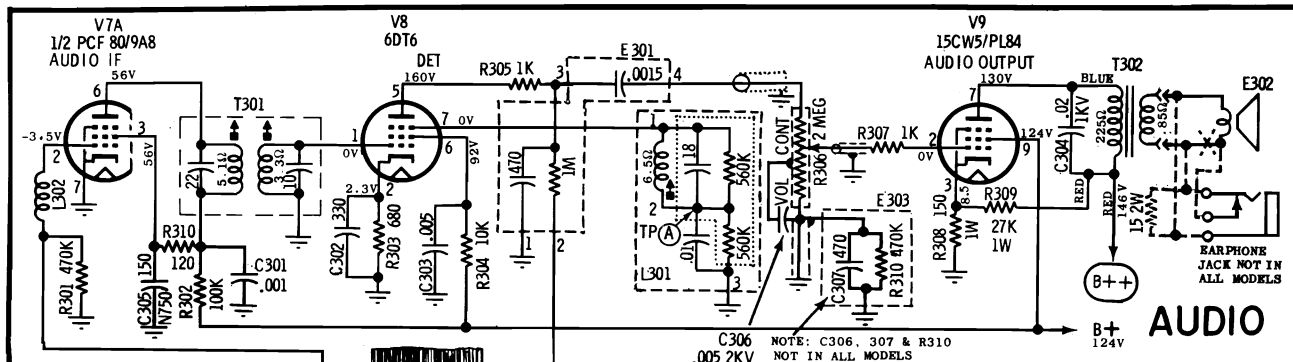

VOLUME TV-24, ADDITIONAL 1965 TELEVISION SERVICING INFORMATION

MOTOROLA Chassis ++TS-586Y Tuner Information, Continued

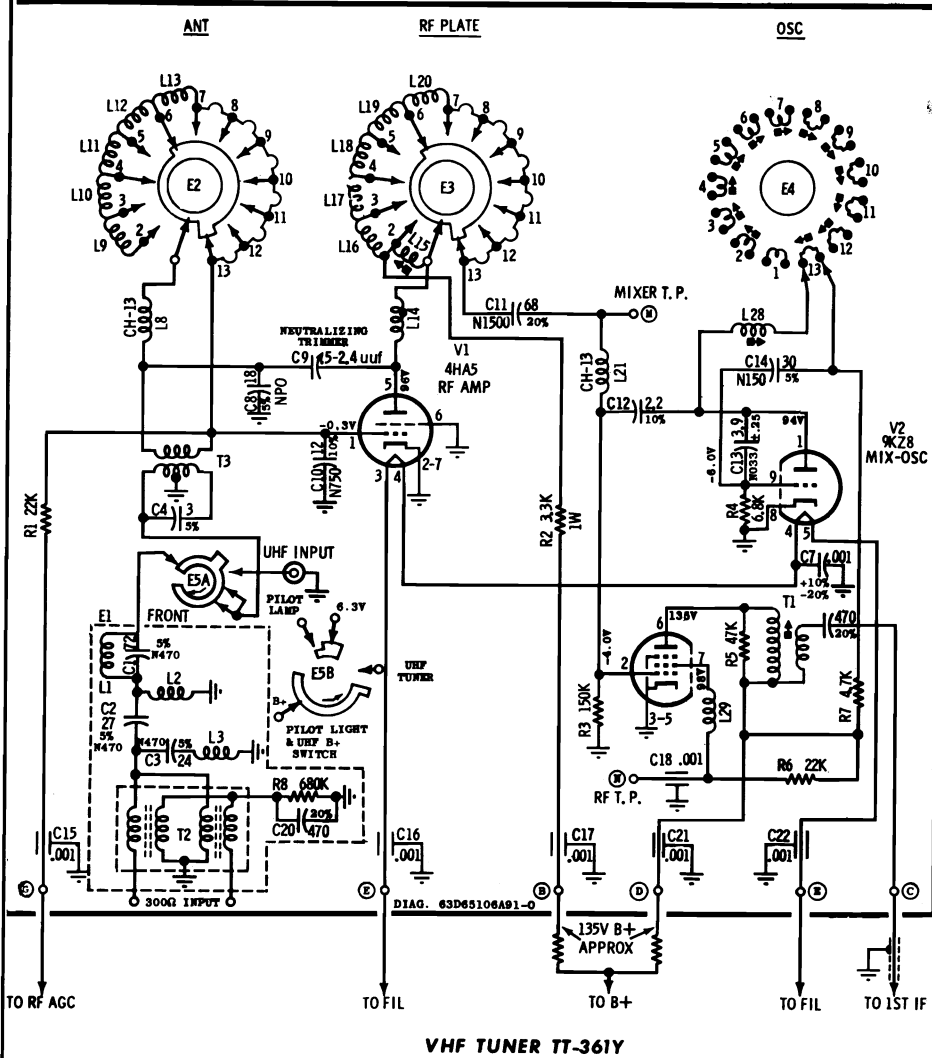

VHF TUNER TT-361Y

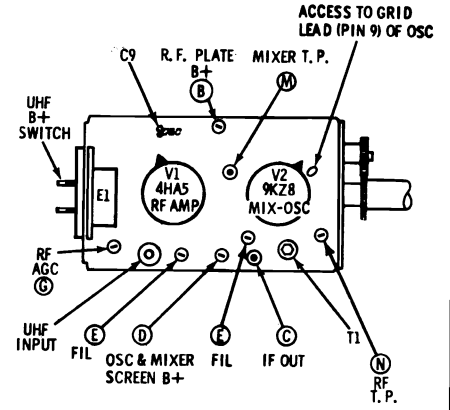

NOTES:
UNLESS OTHERWISE SPECIFIED;
CAPACITORS ARE DISC CERAMIC 500V DC, TOLERANCE & CHARACTERISTIC AS NOTED; IF TOLERANCE IS NOT GIVEN CAPACITORS ARE GMV (GUARANTEED MIN. VALUE) TYPE, DECIMAL VALUES IN MF, ALL OTHERS IN MMF. RESISTORS ARE ALL 10% 1/2 WATT.

VOLTAGES - SEE CHASSIS SCHEMATIC DIAGRAM FOR VOLTAGE NOTES.
CHANNEL SELECTOR IN CHANNEL 13 POSITION
T, P.=TEST POINT
CH=CHANNEL

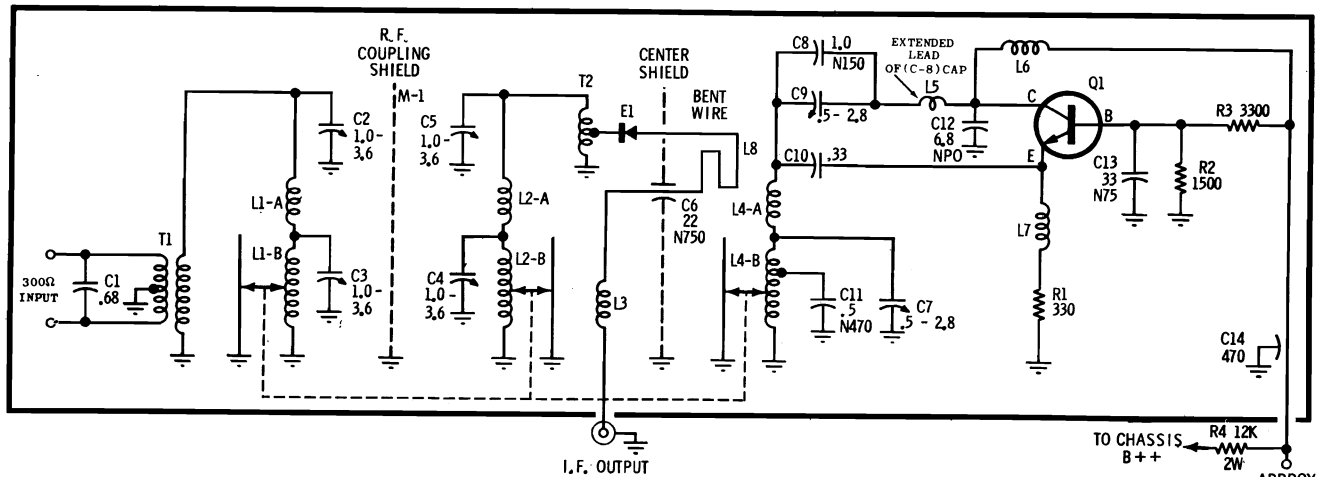
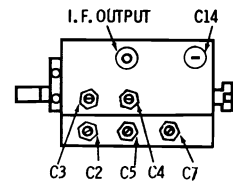

UHF TUNER SCHEMATIC DIAGRAM TT-609



Models 3210, 3211, 3311, 3411, 3519, 3520, 3521, 3522, 3523, 3525, 4310, 7310, 7410, 7510. Material on pages 79 through 84.

T.V. CHASSIS REMOVAL

1. Remove all knobs.
2. Remove screws holding cabinet back.
3. Disconnect H-V lead to CRT.
4. Disconnect socket to CRT.
5. Disconnect black colored grounding wire to CRT tube band.
6. Disconnect speaker wires at the output transformer.
7. Remove yoke from CRT by loosening screw on 'yoke mounting spring'.
8. Remove 4 tuner & control panel mounting screws.
9. Remove 4 chassis mounting bolts from the bottom of the cabinet and slip chassis out of the cabinet.

CLEANING PICTURE TUBE SAFETY GLASS (If so equipped)

1. Remove plastic trim strip on top of safety glass by first removing Phillips screws.
2. Remove and clean glass with soft cloth and cleaner.

TILT ADJUSTMENT

If the picture is tilted, loosen the screw on yoke spring. Rotate the yoke until the tilt is eliminated. Be sure the yoke is seated as far forward on the neck of the tube as possible.

FUSE

The -B circuit is protected with a SLO BLO Type N (3/4 Ampere) fuse. It is located on top of the chassis as seen in Figure 3.

Heater voltage is fused with a 2-1/2" length of #24AWG bare copper wire located under the chassis.

CENTERING ADJUSTMENT

The centering assembly is built into the yoke housing. This assembly is made of two magnetic rings which can be rotated by means of tabs. Centering is accomplished by gradually rotating each tab separately and/or rotating both tabs simultaneously.

HEIGHT AND VERTICAL LINEARITY

These controls are available when the cabinet back is removed. Adjust the height control (R50) as shown in Figure #3 until the picture fills the mask vertically. Adjust the Linearity control (R60) as shown in Figure #3 until the picture is symmetrical from top to bottom. Adjustment of any control will require re-adjustment of the other control. The LINEARITY control has the greatest effect on the upper portion of the picture; the HEIGHT control has the greatest effect on the lower portion of the picture. Adjust the centering device to align picture to mask.

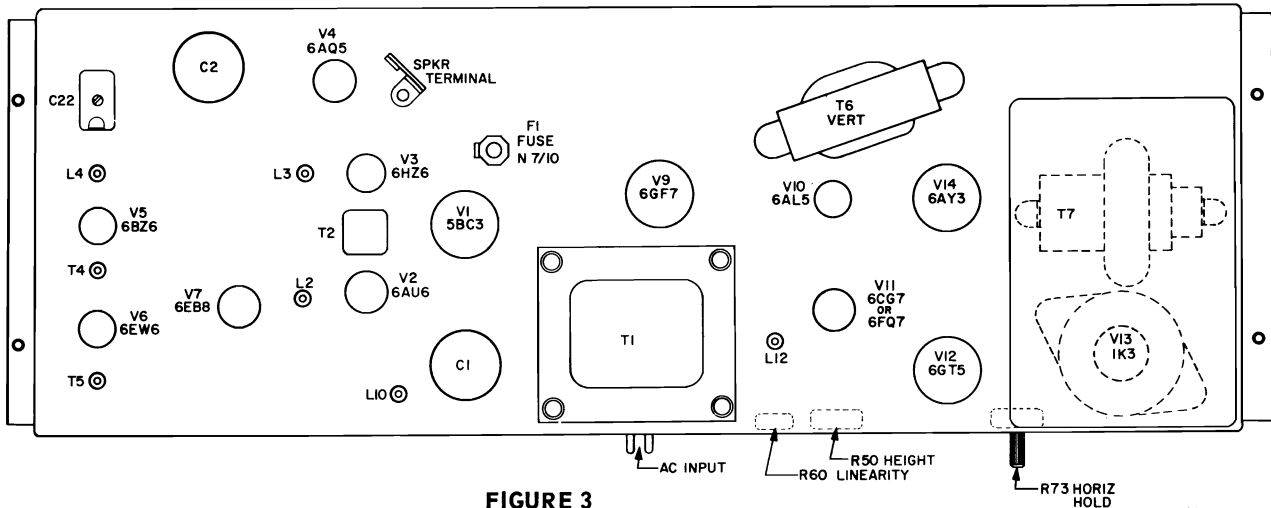
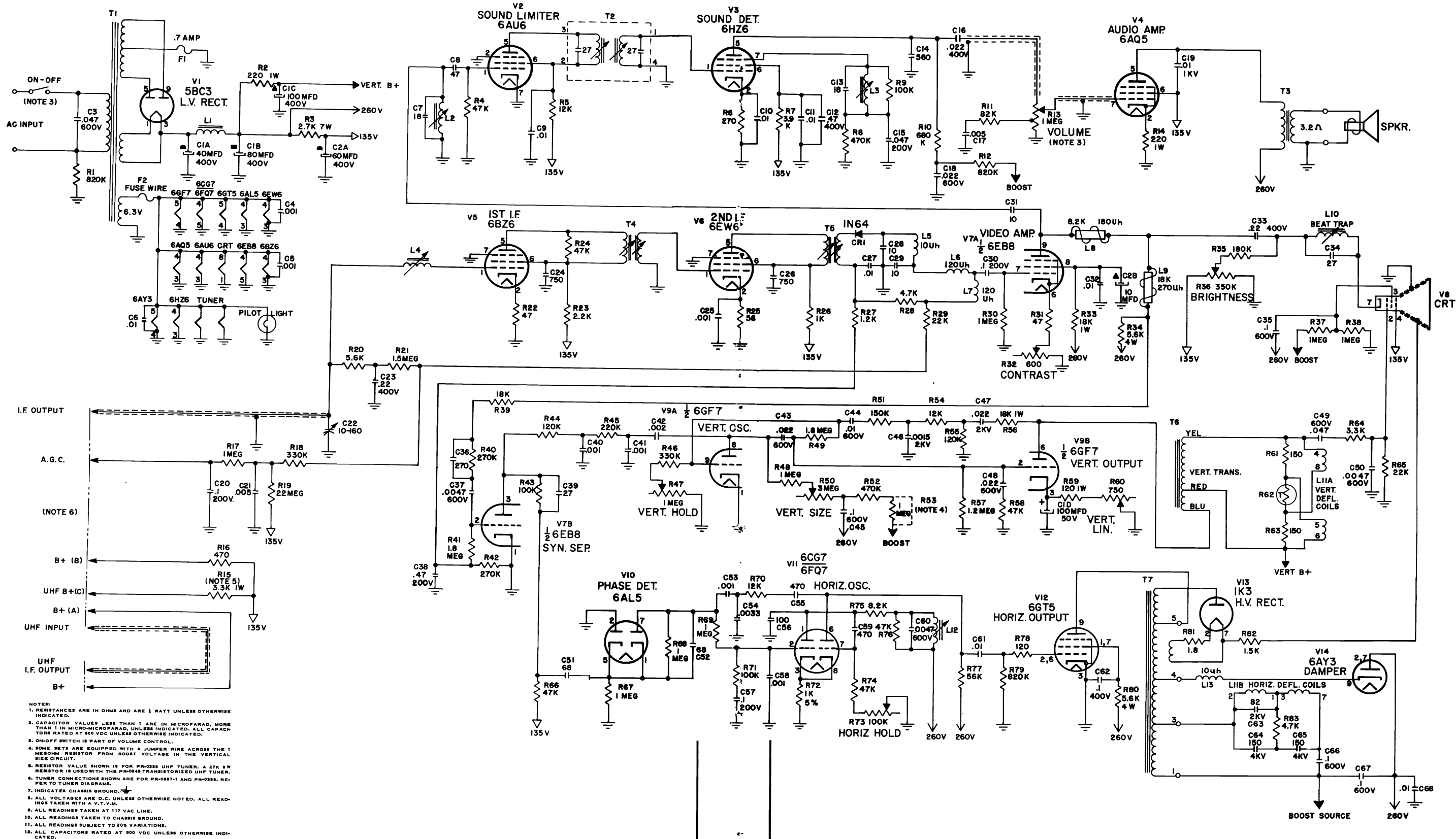

FIGURE 3

MUNTZ TV Models 3210, 3211, 3311, etc. Schematic Diagram



MUNTZ TV Models 3210, 3211, 3311, etc. Schematic Diagram, Continued

- NOTES:
1. RESISTANCE VALUES ARE IN OHMS AND ARE 1/2 WATT UNLESS OTHERWISE INDICATED.
 2. CAPACITOR VALUES LESS THAN 1 ARE IN MICROFARAD, MORE THAN 1 IN MICRO-MICROFARAD, UNLESS INDICATED. ALL CAPACITORS RATED AT 500 VDC UNLESS OTHERWISE INDICATED.
 3. ON-OFF SWITCH IS PART OF VOLUME CONTROL.
 4. SOME SETS ARE EQUIPPED WITH A JUMPER WIRE ACROSS THE 1 MEGOHM RESISTOR FROM BOOST VOLTAGE IN THE VERTICAL SIZE CIRCUIT.
 5. RESISTOR VALUE SHOWN IS FOR PRO-888 UHF TUNER, A 27K 3W RESISTOR IS USED WITH THE PR-0848 TRANSISTORIZED UHF TUNER.
 6. TUNER CONNECTIONS SHOWN ARE FOR PR-0837-1 AND PR-0838. REFER TO TUNER DISGRAME.
 7. INDICATES CHASSIS GROUND.
 8. ALL VOLTAGES ARE D.C. UNLESS OTHERWISE NOTED. ALL READINGS TAKEN WITH A V.T.V.M.
 9. ALL READINGS TAKEN AT 117 VAC LINE.
 10. ALL READINGS TAKEN TO CHASSIS GROUND.
 11. ALL READINGS SUBJECT TO 20% VARIATIONS.
 12. ALL CAPACITORS RATED AT 500 VDC UNLESS OTHERWISE INDICATED.

MUNTZ TV Models 3210, 3211, 3311, etc. Alignment Information

ALIGNMENT OF HORIZONTAL OSCILLATOR

Tune in a good signal and allow the receiver to warm up for a few minutes. Then follow the procedures listed. Refer to chassis layout Figure #3.

1. Tune in the receiver properly and adjust the picture below an over-contrast condition.
2. Short out ringing coil (L12) with a jumper directly across the coil.
3. Short to ground, Pin #2 of V11 (6CG7 or 6FQ7).
4. After receiver is warmed up, adjust Horizontal Hold Control for a single picture.
5. Remove short from Ringing Coil and adjust the core entering the coil from the under chassis side, until a single picture is attained. Then turn approximately 1/4 of a turn clockwise for final adjustment of this coil.
6. Remove short from Pin #2 of V11 to ground and the picture will snap into sync.

FIELD SOUND IF ALIGNMENT

1. Tune up the receiver to any local station. Disconnect the antenna and couple it loosely for acceptable picture and sound level below limiter action level.
2. Connect VTVM diode probe (Figure 4) to pin 7 of the 6HZ6 (V3).
3. Adjust sound IF coil (L2) (peak closer to chassis) and sound IF interstage transformer (T2) (cores from extreme outer positions) for maximum deflection on VTVM being careful that all these adjustments are made below limiting action of limiter.
4. Disconnect diode probe and connect the antenna to the terminals. Tune up to the strongest stations for the best picture and with the volume control set for normal reception. Adjust Quadrature Coil (L3) for the loudest sound peak with minimum distortion.
5. Check the quality of sound alignment by tuning to weak and strong stations. The level of sound should stay the same. If not, repeat the procedure.

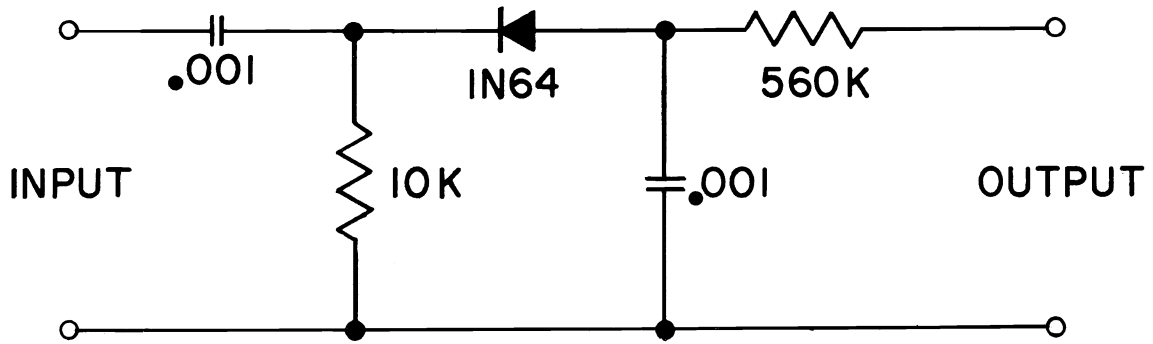

FIGURE 4

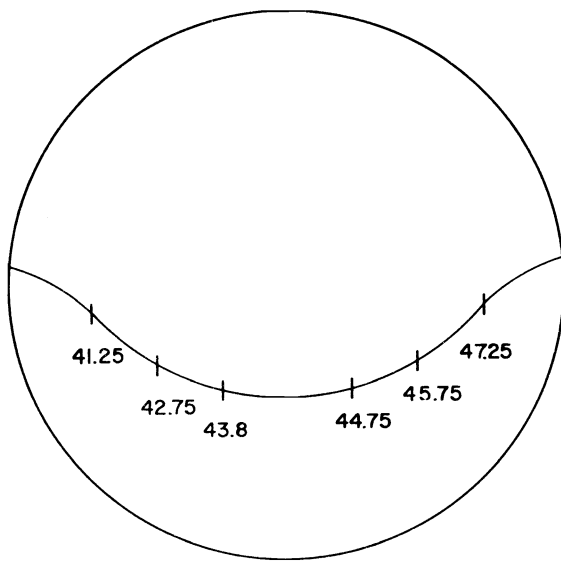

FIGURE 5

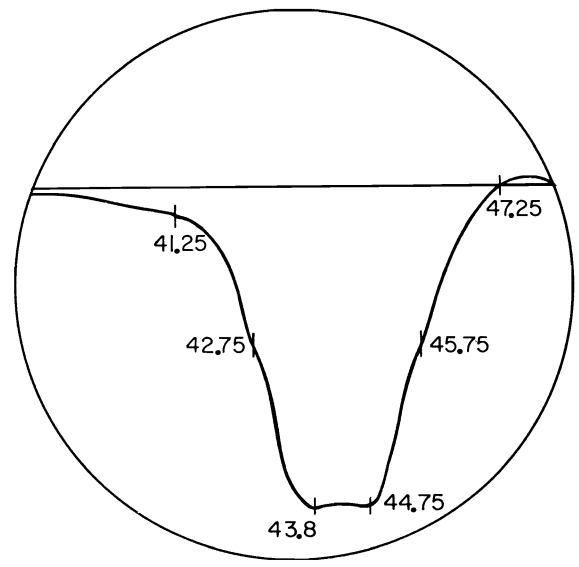

FIGURE 6

VOLUME TV-24, ADDITIONAL 1965 TELEVISION SERVICING INFORMATION

MUNTZ TV Models 3210, 3211, 3311, etc. Alignment Data, Continued

ALIGNMENT INSTRUCTIONS

Connect the negative lead of a 4½ volt battery to the junction of R20 and C23, and the positive lead to the chassis ground. Avoid excessive signal input when using a V.T.V.M. as alignment indicator. This bias is necessary for video IF and sound alignment.

| OVERALL VIDEO I.F. RESPONSE EMPLOYING I.F. CURVE | | | | | | |
|--|--|---------------------------|-------------------------------|--|--|---|
| | SWEEP GENERATOR COUPLING | SWEEP GENERATOR FREQUENCY | CHANNEL NUMBER | MARKER GENERATOR FREQUENCY | ADJUST | SCOPE CONNECTIONS |
| 1. | High side to grid of 2nd IF pin 1 of V6, 6EW6 tube. | 44.00 MC (10 M.C. sweep) | 13 or highest unused channel. | 41.25 MC 42.75 MC 43.80 MC 44.75 MC 45.75 MC 47.25 MC | DET. coil PRI & SEC T5 | Thru a 15K resistor in series with a high Freq. Scope Lead to junctions L6, L7 & C30. Adjust to resemble pattern of Fig. #5. |
| 2. | Thru floating tube shield over converter tube *6CG8. | | | | Interstage coil PRI & Sec T4 1st IF Grid coil L4 IF Output on tuner IF coupling trimmer C22 | Adjust to resemble pattern of Fig. #6. |

*An alternate method is to cut a strip of thin metal ¼ inch wide and 2 inches long, insulating it with one layer of plastic tape and inserting it between the mixer tube and shield. Connect the sweep generator to portion extending above tube shield.

SOUND IF ALIGNMENT PROCEDURE

| | CALIBRATED SIGNAL GENERATOR | SIGNAL GENERATOR FREQUENCY | CHANNEL NUMBER | V.T.V.M. | ADJUST | REMARKS |
|----|--|----------------------------|--|--|--------|---|
| 1. | Connect high side to pin 1 of V7A 6EB8 tube. | 4.5 megacycle modulated. | Any signal free unused channel on VHF. | Connect high side to pin 1 of (V3) 6HZ6 tube using diode probe shown in Fig. #4. | L2 | Volume control set at half way point. Top core. |
| | | | | | T2 | Top & bottom core. |
| 2. | | | | Connect diode probe to pin 7 of 6HZ6 (V3) | T2 | Repeak top slug keeping minimum input signal. This is a very critical adjustment. |
| 3. | | | | Disconnect probe and connect watt-meter to audio output trans. T3 | L3 | Adjust for min. reading using 1/2 watt scale on watt meter. |
| 4. | | | | Loosely couple VTVM using diode probe to cathode lead of CRT socket pin 7 (V8). | L10 | Adjust for minimum reading of deflection. |

VOLUME TV-24, ADDITIONAL 1965 TELEVISION SERVICING INFORMATION

MUNTZ TV Models 3210, 3211, 3311, etc. Service Material, Continued

VOLTAGE CHART

1. ALL VOLTAGES D.C. UNLESS OTHERWISE NOTED. READING TAKEN WITH A V.T.V.M.
2. ALL READINGS TAKEN AT 117 VAC LINE.
3. ALL READINGS TAKEN TO CHASSIS GROUND.
4. ALL READINGS SUBJECT TO 20% VARIATIONS.

| V # | TUBE TYPE | PIN 1 | PIN 2 | PIN 3 | PIN 4 | PIN 5 | PIN 6 | PIN 7 | PIN 8 | PIN 9 | PIN 10 |
|-----|-----------|-------|-------|-------|-------|-------|-------|-------|---------------|-------|--------|
| 1 | 5BC3 | 253 | | 253 | | 289AC | | | T.P. 289AC | 289AC | |
| 2 | 6AU6 | -.25 | GND | GND | FIL. | 60 | 60 | GND | | | |
| 3 | 6HZ6 | 0 | 1.7 | GND | FIL | 160 | 88 | -1.9 | | | |
| 4 | 6AQ5 | N/C | 4.2 | GND | FIL | 245 | 135 | 0 | T.P. | | |
| 5 | 6BZ6 | 0 | +.56 | GND | FIL | 83 | 83 | GND | | | |
| 6 | 6EW6 | 0 | .7 | GND | FIL | 94 | 94 | GND | | | |
| 7 | 6EB8 | GND | 2.2 | 74 | FIL | GND | 5.2 | 0 | 175 | 173 | T.P. |
| V9 | 6GF7 | GND | -21 | 14 | GND | FIL | 207 | -11 | 182 | -51 | |
| V10 | 6AL5 | 4.3 | GND | GND | FIL | 4.3 | GND | -.75 | | | |
| V11 | 6FQ7/6CG7 | 203 | -.75 | 7.5 | FIL | GND | 187 | -12 | 7.5 | GND | N/C |
| 12 | 6GT5 | 132 | -37 | GND | GND | FIL | | | | 920* | |
| 14 | 6AY3 | N/C | N/C | N/C | GND | FIL | N/C | 260 | N/C | 845* | |

* MEASURE WITH A HIGH VOLTAGE METER T.P. = TIE POINT

SARKES TARZIAN TUNER NUMBER PR-0334

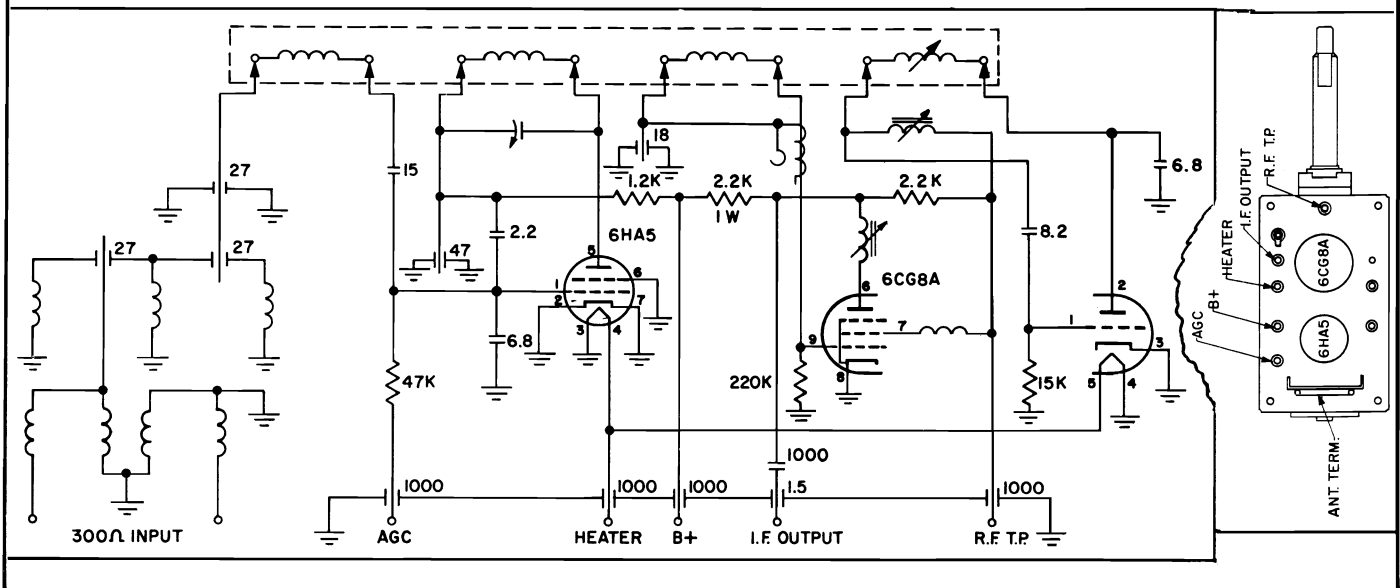

VOLUME TV-24, ADDITIONAL 1965 TELEVISION SERVICING INFORMATION

OLYMPIC Models 9P39U, 9P40, U, Alignment Information

ALIGNMENT INSTRUCTIONS

ALIGNMENT INSTRUCTIONS—READ CAREFULLY BEFORE ATTEMPTING ALIGNMENT

The High Voltage lead should be securely taped and kept away from the chassis.
Allow a 20 minute warm-up period for the receiver and test equipment.

VIDEO IF ALIGNMENT

Connect the synchronized sweep voltage from the sweep generator to the horizontal input of the oscilloscope for horizontal deflection. The generator output lead should be terminated with its characteristic impedance, usually 50 ohms. Use only enough generator output to provide a usable indication on VTVM. Use only enough sweep generator output to provide a usable pattern on scope. Connect variable bias to IF AGC line. Adjust bias to obtain response curve which shows no indication of overloading.

| SWEEP GENERATOR COUPLING | SWEEP GENERATOR FREQUENCY | MARKER GENERATOR FREQUENCY | CHANNEL | CONNECT SCOPE | ADJUST | REMARKS |
|--|---------------------------|----------------------------|-----------------------------|---|---------------------|--|
| High side to IF test point ON Tuner. Low side to chassis. | Not Used | 44.5MC (Unmod.) | Any non-interfering channel | Use VTVM DC probe thru 10K to point. A. Common to chassis. (Across Video Det. Load) | T203 | Adjust for maximum deflection. |
| " | " | 43MC | " | " | T202 | " |
| " | " | 45MC | " | " | T201 | " |
| " | " | 47.25MC | " | " | T205 (TOP) | Adjust for minimum deflection. |
| " | 44MC (10MC sweep) | 43.5MC 45MC | " | Vert. Amp. thru 27K to point. A. Low side to chassis (Across Video Det. Load) | L1 T205 (Bottom) | Check for response similar to Fig 1. If necessary retouch T201 thru T203 and L1 T205(BOTTOM) as required for desired response. |

SOUND IF ALIGNMENT

Turn the set on disconnecting the antenna and if necessary, insert an attenuator in series with the antenna to provide a weak signal. (a weak signal is necessary to make the peaks distinguishable.)
Adjust T206(top) and T204(bottom) for maximum volume. Adjust T204(top) for maximum undistorted sound.

4.5MC TRAP ALIGNMENT

Connect the antenna directly for a strong signal and set picture at maximum.
Adjust the Fine Tuning until a beat pattern is visible.
Adjust T206(bottom) for minimum beat interference.

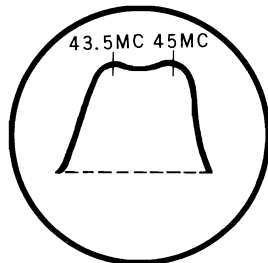
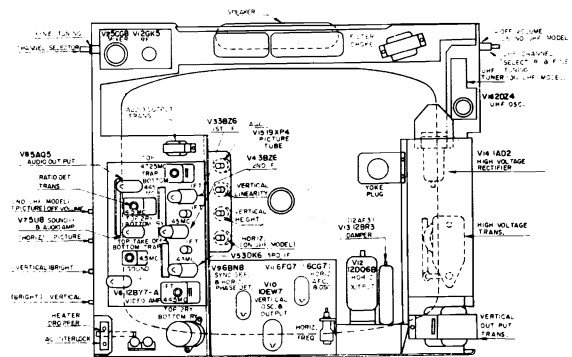

FIG. 1

TUBE SOCKET LAYOUT



HORIZONTAL SWEEP CIRCUIT ADJUSTMENTS

1. Turn the set on and allow it warm up for 2 minutes.
2. Tune in a TV station, preferably with a test pattern.
3. Turn the Horizontal Hold Volume fully in clock wise direction.
4. Rotate Horizontal Frequency control coil in Clock-wise direction until picture falls out of horizontal sync. (if picture is not out of sync at the end of the control range, momentarily switch tuner to "free" channel and then return to original.)
5. Reverse rotation of Frequency Control slowly until picture falls into sync.

VOLUME TV-24

OLYMPIC
9P39U, 9P40, U
(Continued)

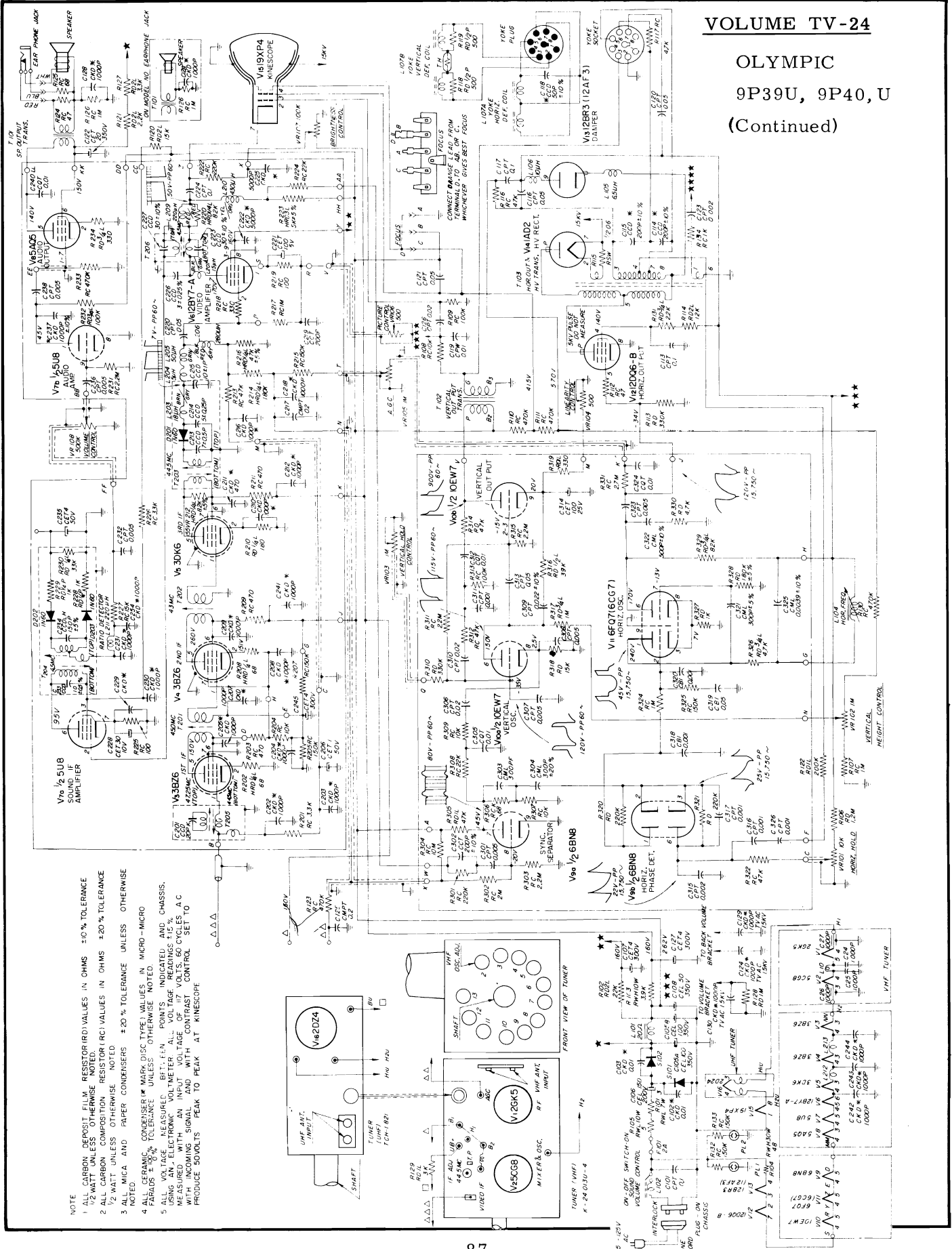

- NOTE
- 1 ALL CARBON DEPOSIT FILM RESISTOR (R) VALUES IN OHMS ±10% TOLERANCE
 - 2 1/2 WATT UNLESS OTHERWISE NOTED
 - 3 ALL CARBON COMPOSITION RESISTOR (RC) VALUES IN OHMS ±20% TOLERANCE
 - 4 1/2 WATT UNLESS OTHERWISE NOTED
 - 5 ALL CERAMIC CONDENSER (C) VALUES IN MICRO-MICRO FARADS ±10% TOLERANCE UNLESS OTHERWISE NOTED
 - 6 ALL CERAMIC CONDENSER (C) VALUES IN MICRO-MICRO FARADS ±10% TOLERANCE UNLESS OTHERWISE NOTED
 - 7 ALL VOLTAGE MEASURED BFT. F.N. POINTS INDICATED AND CHASSIS. USING AN ELECTRONIC VOLTMETER. ALL VOLTAGE READINGS ±1% MEASURED WITH SIGNAL AND WITH TAGS IN POSITION. ALL A.C. PRODUCE SIGNALS PEAK TO PEAK AT KINESCOPE

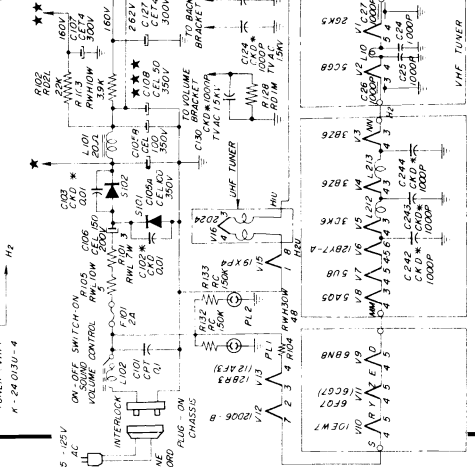
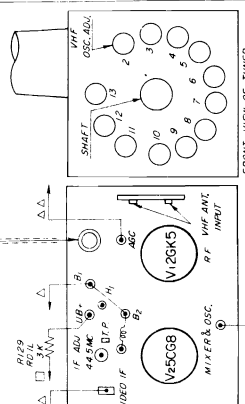
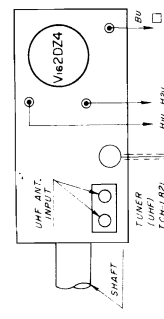

VOLUME TV-24, ADDITIONAL 1965 TELEVISION SERVICING INFORMATION

OLYMPIC Models .9P39U, 9P40, U, Service Information, Continued

RESISTANCE MEASUREMENTS

| ITEM | TUBE | Pin 1 | Pin 2 | Pin 3 | Pin 4 | Pin 5 | Pin 6 | Pin 7 | Pin 8 | Pin 9 |
|------|----------------|------------|-------|-------|-------|-------|-------|-------------|-------|------------|
| V1 | 2GK5 | 0Ω | 700KΩ | — | — | 60KΩ | 0Ω | 0Ω | | |
| V2 | 5C68 | 10KΩ | 60KΩ | 0Ω | — | — | 60KΩ | 0Ω | 0Ω | 250KΩ |
| V3 | 3BZ6 | 60KΩ | 50KΩ | — | — | 60KΩ | 60KΩ | 0Ω | | |
| V4 | 3BZ6 | 60KΩ | 60KΩ | — | — | 60KΩ | 60KΩ | 60KΩ | | |
| V5 | 3DK6 | 0Ω | 180KΩ | — | — | 60KΩ | 60KΩ | 0Ω | | |
| V6 | 12BY7-A | *1 100Ω | 1MΩ | 0Ω | — | — | — | 65KΩ | 80KΩ | 0Ω |
| V7 | 5U8 | 160KΩ | 4Ω | 80KΩ | — | — | 80KΩ | 100Ω | 0Ω | 5MΩ |
| V8 | 5AQ5 | 470KΩ | 330Ω | — | — | 65KΩ | 68KΩ | 470KΩ | | |
| V9 | 6BN8 | 500KΩ | 250KΩ | 250KΩ | — | — | 50KΩ | 70KΩ | 2MΩ | 0Ω |
| V10 | 18DE7 18EW7 | 60KΩ | 2MΩ | 2MΩ | — | — | 2.5MΩ | *2 500KΩ | 15KΩ | *3 600Ω |
| V11 | 6E67 6FQ7 | 65KΩ | 1.5MΩ | 1KΩ | — | — | 140KΩ | 180KΩ | 1KΩ | 0Ω |
| V12 | 12DQ6-B | NC | — | NC | 70KΩ | 330KΩ | NC | — | 0Ω | |
| V13 | 12BR3 | — | — | — | — | — | — | — | — | — |
| V14 | 1AD2 | ∞ | ∞ | ∞ | ∞ | ∞ | ∞ | ∞ | ∞ | *4 390Ω |
| V15 | 19XP4 | 0Ω | 100KΩ | 600KΩ | 600KΩ | NC | NC | *5 200KΩ | — | |
| ITEM | TUBE | Pin 1 | Pin 2 | Pin 3 | Pin 4 | Pin 5 | Pin 6 | Pin 7 | Pin 8 | Pin 9 |

NC NO CONNECTION

* 1 THIS READING WILL VARY DEPENDING UPON THE CONDITION OF PICTURE.

* 2 THIS READING WILL VARY DEPENDING UPON THE CONDITION OF VERTICAL HOLD.

* 3 THIS READING WILL VARY DEPENDING UPON THE CONDITION OF VERTICAL LINEA.

* 4 MEASURED FROM PLATE PIN OF V12.

* 5 THIS READING WILL VARY DEPENDING UPON THE CONDITION OF BRIGHT.

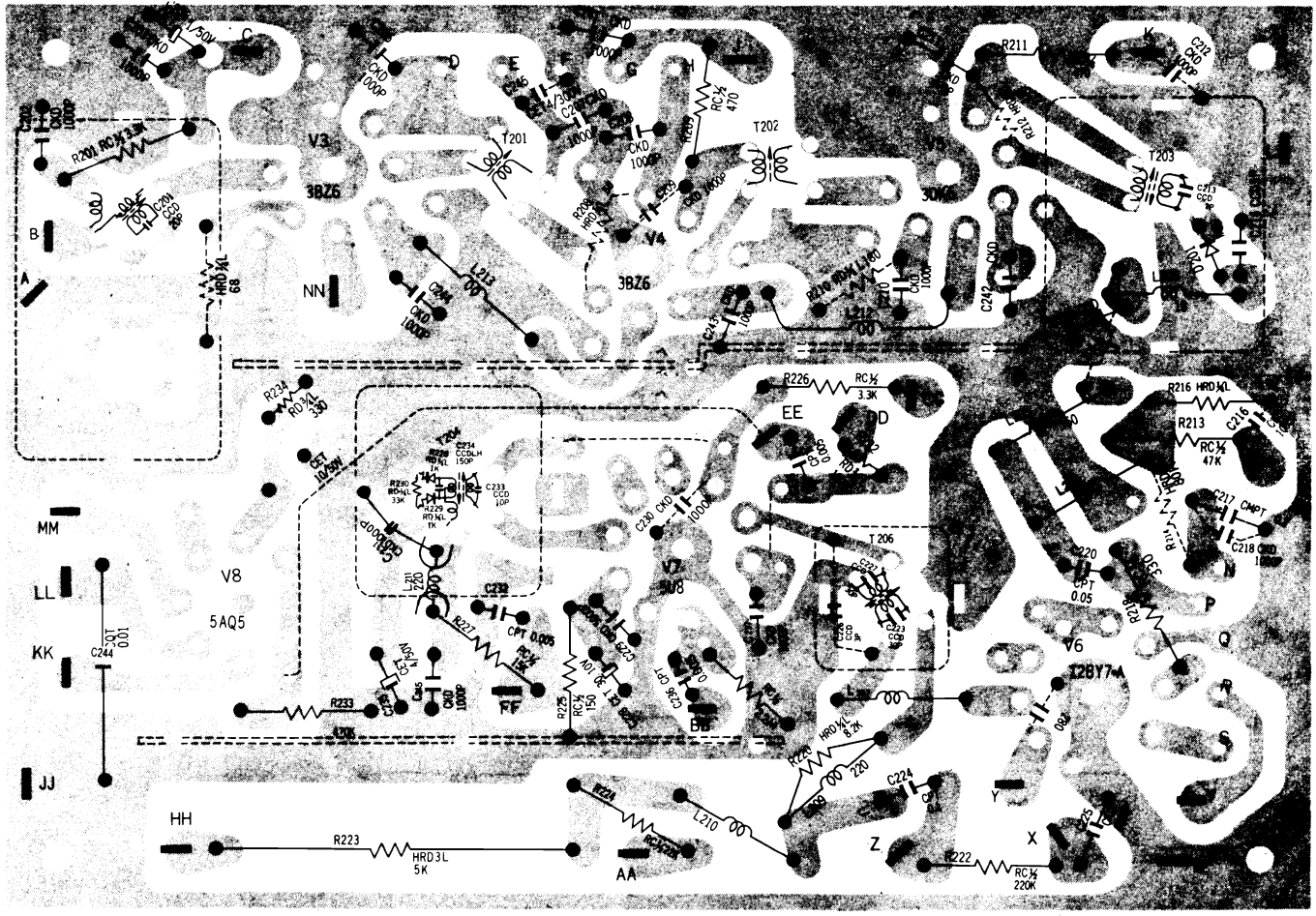
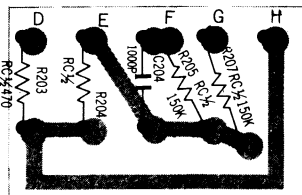
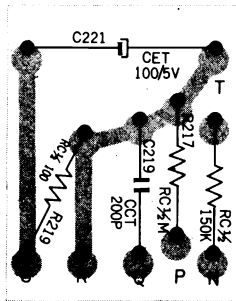

VOLUME TV-24, ADDITIONAL 1965 TELEVISION SERVICING INFORMATION

PHILCO Chassis N1200 & N1204 Service Information, Continued

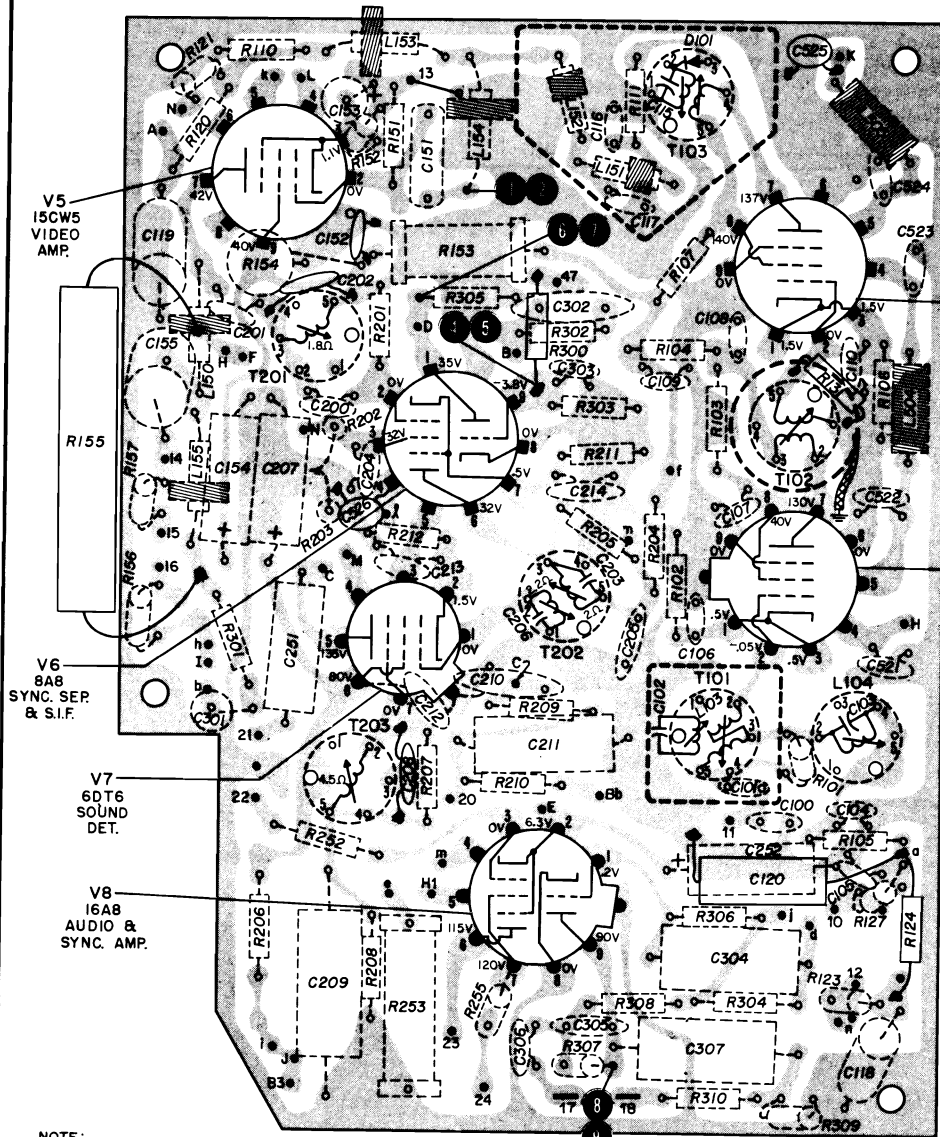

N1200 IF-AUDIO PANEL CONNECTIONS

| LEAD COLOR | FROM | TO |
|------------|---------|----------------------------|
| White | A | n(R123) |
| Yellow | B | b |
| Brown | Bb | R418 |
| Orange | B3 | C506A |
| Red | C | c |
| Red | D | d |
| Green | E | e |
| Orange | F | f |
| Orange | H(F) | h |
| White | H(V3-4) | R502 bottom lug |
| Blue | H1 | C17T on VHF Tuner |
| Orange | J | i |
| Orange | J | j |
| Blue | K | k |
| Blue | L | l |
| Blue | M | m |
| Brown | N | n(R205) |
| Green | N(R121) | VR101 pin 3 (contrast) |
| White | N(R123) | C5T on VHF Tuner (AGC) |
| Brown | 10 | R202 & R203 junction |
| White | 10 | SW2 (AGC switch) |
| IF cable | 11 | C10T (Tuner) |
| Yellow | 12 | R129 & R130 junction |
| Green | 14 | L101 (4.5MC trap) |
| Brown | 15 | VR102 pin 2 (brightness) |
| Red | 16 | VR102 pin 1 (brightness) |
| Yellow | 17 | 41 on Horiz. osc. panel |
| Green | 18 | 31 on Vert. osc. panel |
| Red | 20 | Focus panel |
| Blue | 21 | VR201 pin 3 (volume) |
| Grey | 22 | VR201 pin 2 (volume) |
| Red | 23 | T204 Audio transf. |
| Brown | 24 | C506C |
| White | VR101-2 | R123, R124 & C118 junction |

NOTE:

VOLTAGE MEASURED WITH VTVM FROM GROUND WITH NO SIGNAL AND ALL CONTROLS SET FOR NORMAL OPERATION. RESISTANCES MEASURED IN CIRCUIT.

Bottom View, IF-Audio Perma-Circuit Panel Component Layout

N1200 RESISTANCE CHART

| SYMBOL | TUBE | | PIN NUMBERS | | | | | | | | |
|--------|-------|----------------------|-------------|-------|------|-----|-------|--------|-------|------|-------|
| | | | 1 | 2 | 3 | 4 | 5 | 6 | 7 | 8 | 9 |
| V3 | 6EH7 | 1ST VIF | 33Ω | 2.5MΩ | 33Ω | FIL | FIL | 0Ω | 17KΩ | 40KΩ | 0Ω |
| V4 | 6EJ7 | 2ND VIF | 82Ω | 0Ω | 82Ω | FIL | FIL | 0Ω | 13KΩ | 13KΩ | 0Ω |
| V5 | 15CW5 | VID. OUT. | | 820KΩ | 47Ω | FIL | FIL | 1NF. | 20KΩ | 1NF. | 125KΩ |
| V6 | 8AB | 1ST IF AND SYNC. SEP | 18KΩ | 39KΩ | 15KΩ | FIL | FIL | 12.5KΩ | 270Ω | 0Ω | 1.2MΩ |
| V7 | 6DT6 | SND. DET. | 1.5Ω | 560Ω | FIL | FIL | 900KΩ | 38KΩ | 600KΩ | | |

PIN NUMBERS

| SYMBOL | TUBE | | PIN NUMBERS | | | | | | | | |
|--------|-------|----------------------|-------------|-------|--------|------|-------|--------|-------|--------|--------|
| | | | 1 | 2 | 3 | 4 | 5 | 6 | 7 | 8 | 9 |
| V8 | 16AB | AUD. OUT & SYNC SEP. | 350KΩ | 170Ω | 1.2KΩ | FIL | FIL | 16.5KΩ | 18KΩ | 0Ω | 30KΩ |
| V9 | 18GV8 | VERT. OSC. & OUT. | 4.2MΩ | 1MΩ | 0Ω | FIL | FIL | 12KΩ | 12KΩ | 100Ω | 1.4MΩ |
| V10 | 17A8 | HORIZ. OSC. & AFC | 45KΩ | 302KΩ | 15.5KΩ | FIL | FIL | 15.5KΩ | 220KΩ | 0Ω | 280KΩ |
| V11 | 50Y6 | HOR. OUT | | FIL | 24KΩ | 15KΩ | 680KΩ | FIL | 0Ω | 0Ω | |
| V12 | 34R3 | DAMPER | | | FIL | FIL | | | | 15.5KΩ | 15.5KΩ |

VOLUME TV-24, ADDITIONAL 1965 TELEVISION SERVICING INFORMATION

PHILCO Chassis N1200 & N1204 Alignment Information, Continued

N1200 VIDEO I-F AM AND SWEEP ALIGNMENT PROCEDURE

The following video if alignment procedure is based upon a tuner, with proper bandpass alignment, connected to the TV chassis.

1. Apply -4.5 volts dc to if agc point at junction of R105, C105 and R127.
2. Connect oscilloscope through 10K isolating resistor to video detector output at pin 2 of V5 (15CW5).
3. Preset top and bottom cores of T101 halfway out of transformer; set tuner on channel 13.
4. Inject 40 mc sweep to pin 2 of V4 (6EJ7). Make sure sweep is not in overload. Marker level should be such that output level is not affected.

Note: 3 & 4 above are for if sweep alignment only.

5. Remove 40 mc sweep.
Caution: Do not attempt to adjust T103 top or bottom cores after they have been 40 mc sweep-aligned.
6. Connect am signal generator through .002mf capacitor to tuner mixer grid (test point on tuner); also connect -3-volt, dc bias through 220K resistor to tuner test point.
7. Connect sweep generator through 72- to 300-ohm matching network to antenna input terminals on tuner for rf alignment.

I-F SWEEP ALIGNMENT CHART

| STEP | SWEEP GEN. APPROX. 8 MC SWEEP WIDTH | MARKER GEN. UNMOD. RF | ADJUST | REMARKS |
|------|-------------------------------------|-----------------------|----------------|---|
| 1 | 44 MC | 42.5 MC AND 45.75 MC | T103 TOP CORE | ADJUST TO PLACE 42.5 MC AND 45.75 MC MARKER BETWEEN INDICATED LIMITS SHOWN IN FIGURE A. |
| 2 | 44 MC | 42.5 MC AND 45.75 MC | T103 BOT. CORE | ADJUST BY ROCKING CURVE TO PLACE 42.5 MC AND 45.75 MC MARKERS BETWEEN INDICATED LIMITS SHOWN IN FIGURE A. |

AM ALIGNMENT

| STEP | AM MOD. 400~ AT 50% | ADJUST | REMARKS |
|------|---------------------|------------------------------|---|
| 3 | 44.5 MC | T102 FOR MAXIMUM | ADJUST INPUT LEVEL TO PREVENT OVERLOADING. |
| | 42.5 MC | L7T (ON TUNER) FOR MAXIMUM | |
| 4 | 44.5 MC | T101 BOTTOM CORE FOR MAXIMUM | ADJUST BIAS AS NECESSARY TO PRODUCE SUFFICIENT SCOPE AMPLITUDE. |
| | 41.25 MC | T101 TOP CORE FOR MINIMUM | |
| | 45.25 MC | L104 FOR MINIMUM | |

NOTE: TO PROPERLY POSITION FINE TUNING FOR SWEEP ALIGNMENT, SET CHANNEL SELECTOR TO CHANNEL 4 AND INJECT 65.75 MC MODULATED 30% AT ANTENNA TERMINALS. ADJUST FINE TUNING CONTROL FOR MINIMUM SCOPE INDICATION. DO NOT TOUCH FINE TUNING CONTROL OR CHANNEL SELECTOR FOR BALANCE OF ALIGNMENT.

R-F SWEEP ALIGNMENT

| STEP | SWEEP GEN. APPROX. 8 MC SWEEP WIDTH | MARKER GEN. UNMOD. RF | ADJUST | REMARKS |
|------|-------------------------------------|-----------------------|----------------------|---|
| 5 | 69 MC | 42.5 MC | L7T (TUNER I-F COIL) | ADJUST L7T TO PLACE 42.5 MC MARKER BETWEEN INDICATED LIMITS ON SOUND SIDE OF CURVE FIG. B. KEEP RESPONSE LEVEL WITH T102. |
| 6 | 69 MC | 45.75 MC | T101 BOTTOM CORE | ADJUST T101 BOTTOM CORE TO PLACE MARKER 45.75 MC BETWEEN INDICATED LIMITS ON CURVE FIG. B. KEEP RESPONSE LEVEL WITH T102. |
| 7 | 69 MC | 42.5 MC AND 45.75 MC | T102 | T102 TILTS OR LEVELS CURVE. |

VOLUME TV-24, ADDITIONAL 1965 TELEVISION SERVICING INFORMATION

PHILCO Chassis N1200 & N1204 Alignment Information, Continued

4.5 MC TRAP, SOUND TAKE-OFF AND INTERSTAGE ALIGNMENT

PRELIMINARY

1. Set contrast control to maximum.
2. Set volume control to minimum.
3. Connect -4.5 volts, agc bias, to junction of R105, C105 and R127.
4. Connect jumper across T203 detector coil for

steps A and B. Remove for steps C and D.

EQUIPMENT

1. Rf sweep generator
2. Am-rf marker generator
3. Vtvm with 4.5 mc detector probe

| STEP | SIGNAL INPUT TO PIN 2 OF V5 15CW5 | OUTPUT CONNECTION | ADJUST | REMARKS |
|------|-----------------------------------|---|---------------------------|--------------------------------------|
| A | 4.5 MC AM OR STATION SIGNAL | CONNECT VTVM WITH 4.5 MC DETECTOR PROBE TO PIN 6 OF V6A(8A8) | T201 FOR MAXIMUM OUTPUT | |
| B | SAME AS STEP A | CONNECT VTVM WITH 4.5 MC DETECTOR PROBE TO PIN 5 OF V7(6DT6) | T202 FOR MAXIMUM OUTPUT | ADJUST TOP AND BOTTOM CORES OF T202. |
| C | SAME AS STEP A | CONNECT VTVM TO PIN 5 OF V7(6DT6) (WITHOUT DETECTOR PROBE) | T203 FOR MAX. SND. OUTPUT | REMOVE JUMPER FROM T203 |
| D | SAME AS STEP A | CONNECT VTVM WITH 4.5 MC DETECTOR PROBE TO PIN 7 (CATHODE) OF CRT | L101 FOR MINIMUM OUTPUT. | 4.5 MC TRAP |

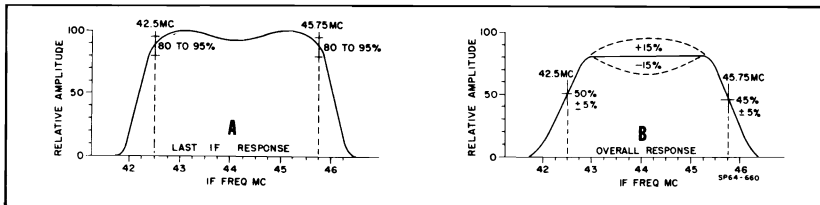

IF Response Curves

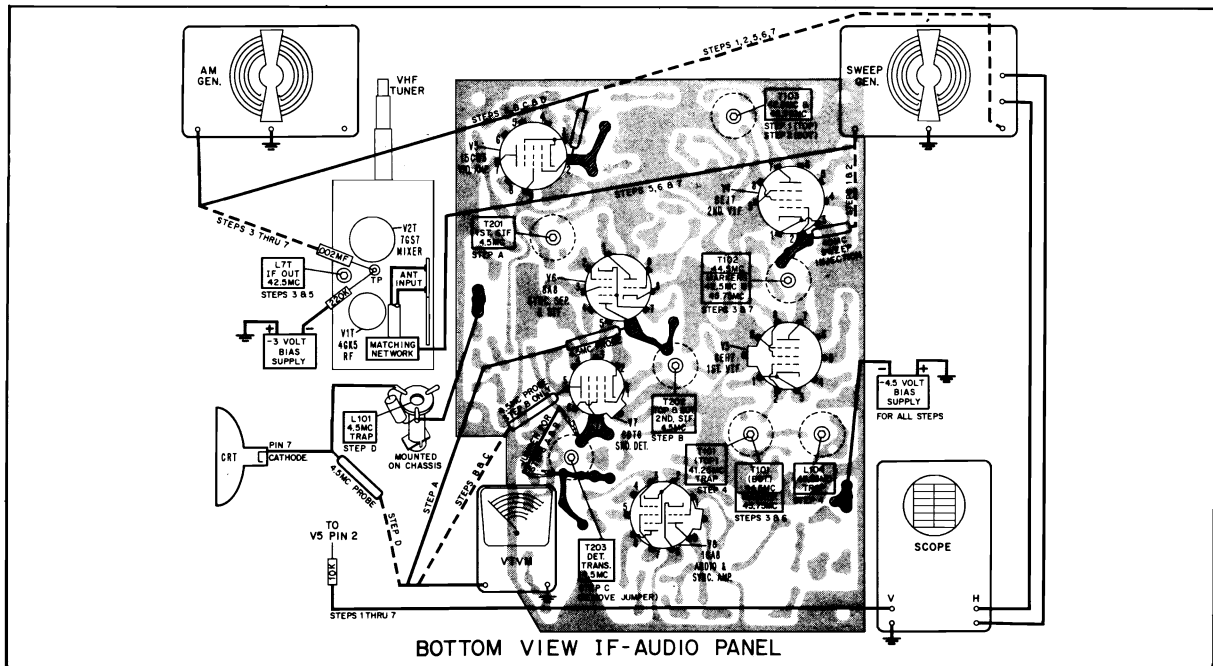

Test Equipment Setup & Alignment Points

RCA VICTOR

VHF LOCAL OSCILLATOR ADJUSTMENT (In Cabinet Procedure)

Turn tuner to the highest channel that can be received in the high VHF band (Channels 7-13). Rotate fine tuning control 3 turns clockwise, then 1 turn counterclockwise. Adjust Channel 13 oscillator screw (L32) for best reception. Next turn to highest local channel in the low VHF range (Channel 2-6) and set fine tuning at approximate center of its range (3 turns cw then 1 turn ccw). Adjust Channel 6 oscillator screw (L39) for best reception.

AGC CONTROL ADJUSTMENT

Perform the following, routine test: Adjust the receiver and antenna to obtain the best picture from a strong, local station. Quickly switch off channel and back, and if the picture distorts and bends, or does not reappear at once, rotate the agc control (R501) counterclockwise and then clockwise until slight picture bend occurs. Then slowly retard the control until the bend is gone. Check again by switching off and on strong signal.

WIDTH

The width adjustment is made with L101. The picture may be adjusted to fill the mask with a line voltage of 108 volts; and with normal line voltage, the raster should overscan the mask about 5/8 inch on each side. "Normal" line voltage is 120 volts.

| MODEL | CHASSIS | NAME |
|---------------|----------|-------------|
| AF-045J | KCS142AC | "BONANZA" |
| AF-049E, H, T | KCS142AA | "HEADLINER" |
| AF-095H, J, T | KCS142R | "TALISMAN" |

Service material below and on the next four pages. For alignment see data on pages 134-136, of TV-23, Early 1965 TV Manual. Also Chassis KCS-142U, used in Models AF-090E, H, and KCS-142XA, Models AG-095ER, WR, YR, are similar to sets in this section.

HORIZONTAL OSCILLATOR

The horizontal sine wave coil is adjusted by temporarily attaching a short jumper across the coil (L501A) and another jumper from Pin 2 of the 8LC8 to ground. Carefully adjust the horizontal hold for least sideways drift of the picture and remove the coil jumper. Again stop the sideways drift (if any) by adjusting the sine wave coil slug with nonmetallic tool. Remove all jumpers. See Zone 3A, PW500 Board for location of L501.

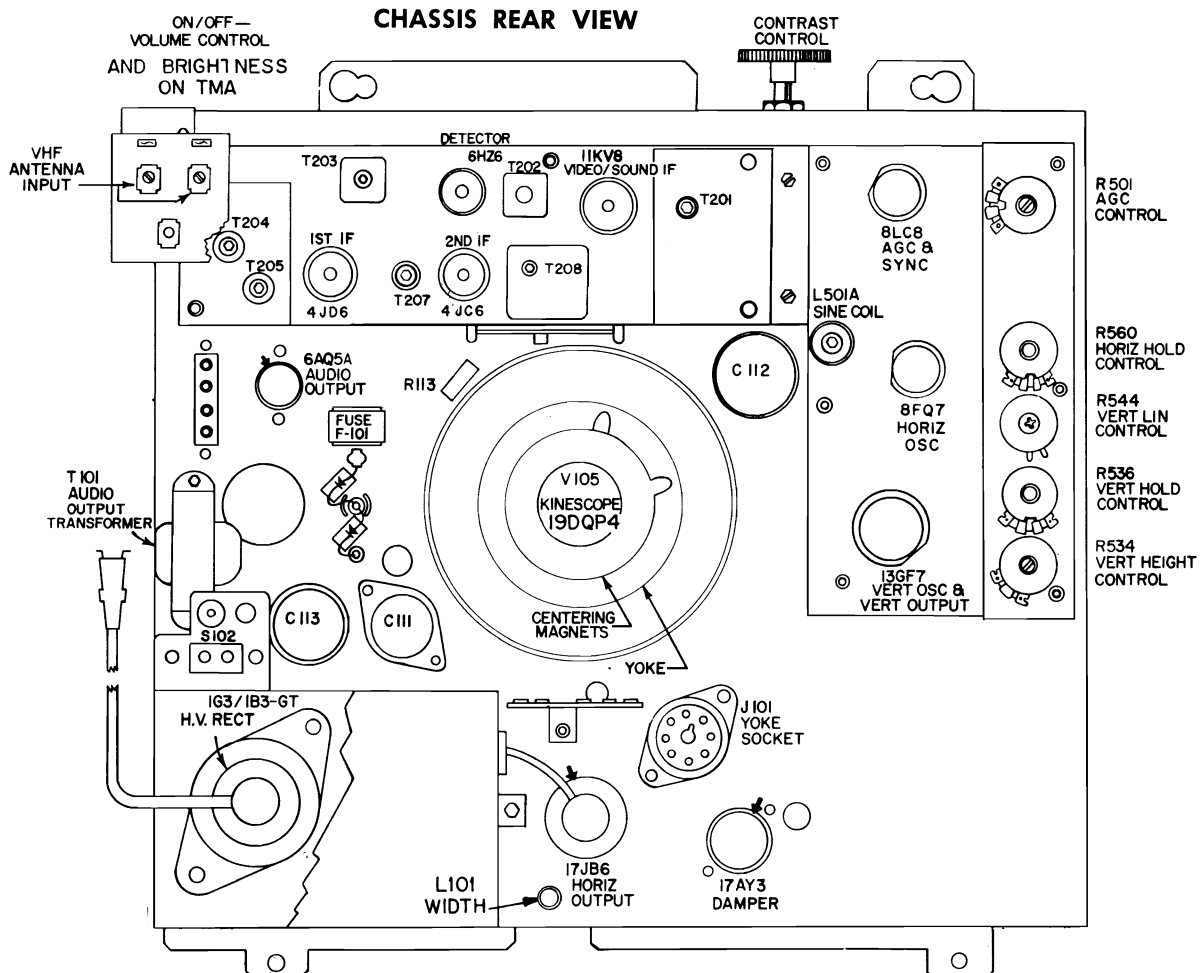

VOLUME TV-24, ADDITIONAL 1965 TELEVISION SERVICING INFORMATION

RCA Victor Chassis KCS-142AA, AC, R, Board Views

PW200—I-F, VIDEO BOARD

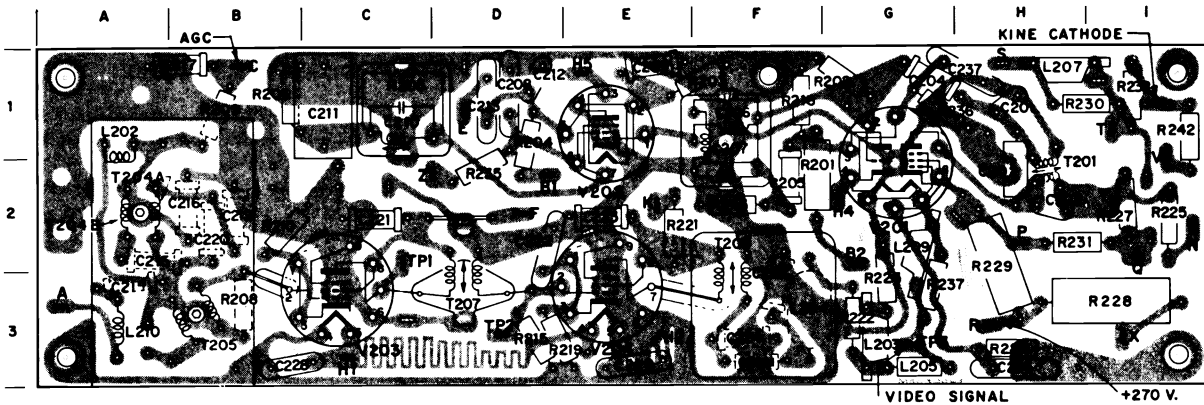

PW200 LOCATION GUIDE

| | | | | | | | |
|------|----------|-------|----------|-------|----------|-----|----------|
| C201 | 1H | C237 | 1H | R224 | 3H | B1 | 2D |
| C202 | 2H | | | R225 | 2I | B2 | 2G |
| C203 | 2H | CR201 | 3F | R227 | 2I | C | 1B |
| C204 | 1G | | | R228 | 3I | E | 1D |
| C205 | 2F | L202 | 1A | R229 | 2H | F | 2D |
| C206 | 1F | L203 | 3G | R230 | 1I | H1 | 3C |
| C207 | 1F | L204 | 3F | R231 | 2H | H2 | 3E |
| C208 | 1D | L205 | 3G | R232 | 1I | H4 | 2G |
| C209 | 1E | L207 | 1H | R235 | 2D | H5 | 1E |
| C210 | 1C | L209 | 2G | R236 | 1H | K | 2E |
| C211 | 1C | L210 | 3A | R237 | 3G | N | 2I |
| C212 | 1D | | | R242 | 1I | P | 2H |
| C213 | 1D | R201 | 2F | R243 | 2F | Q | 2I |
| C214 | 3A | R202 | 1G | | | R | 3H |
| C215 | 2A | R203 | 1F | T201 | 2H | S | 1H |
| C216 | 2B | R204 | 1D | T204A | 2A | T | 1I |
| C217 | 1B | R205 | 1C | T204B | 2A | TP1 | 2C |
| C219 | 2B | R206 | 1B | T205 | 3B | TP2 | 3D |
| C220 | 2B | R208 | 3B | T207 | 3D | TP3 | 3G |
| C221 | 2C | R209 | 1B | T208 | 2F | U | 1I |
| C222 | 2D | R210 | 2B | | | V | 2I |
| C223 | 2E | R215 | 3D | V201 | 2G | X | 3I |
| C224 | 3F | R216 | 1F | V202 | 2E | Y | 2I |
| C225 | 3F | R219 | 3D | V203 | 3C | Z | 2C |
| C226 | 3H | R221 | 2E | V204 | 3E | | |
| C228 | 3B | R222 | 3G | | | | |
| C229 | 3E | R223 | 3G | A | 3A | | |

PW500 DEFLECTION BOARD

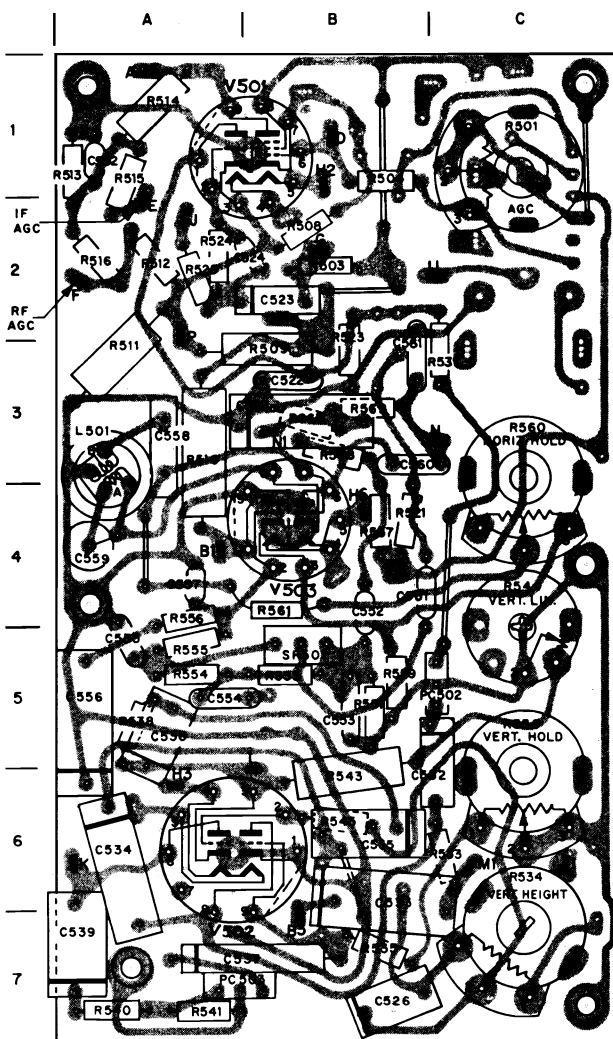

PW500 LOCATION GUIDE

| | | | | | | | |
|------|----------|-------|----------|------|----------|-------|----------|
| C502 | 1A | C556 | 5A | R511 | 3A | R543 | 6B |
| C521 | 3B | C557 | 4A | R512 | 2A | R544 | 4C |
| C522 | 3B | C558 | 3A | R513 | 1A | R545 | 6B |
| C523 | 3B | C559 | 4A | R514 | 1A | R551 | 5B |
| C524 | 2B | C560 | 3B | R515 | 1A | R553 | 5B |
| C526 | 7B | C562 | 3B | R516 | 2A | R554 | 5A |
| C532 | 6C | | | R521 | 4B | R555 | 5A |
| C533 | 6B | L501 | 3A | R523 | 2B | R556 | 4A |
| C534 | 6A | | | R524 | 2A | R557 | 4B |
| C535 | 6B | PC502 | 5C | R525 | 2A | R558 | 3B |
| C536 | 5A | PC503 | 7B | R531 | 3C | R559 | 5B |
| C537 | 7A | | | R533 | 6C | R560 | 3C |
| C539 | 7A | R501 | 1C | R534 | 6C | R561 | 4B |
| C551 | 4B | R503 | 2B | R535 | 7B | R562 | 3B |
| C552 | 4B | R504 | 1B | R536 | 5C | R563 | 3B |
| C553 | 5B | R508 | 2B | R538 | 5A | | |
| C554 | 5A | R509 | 3B | R540 | 7A | SR501 | 5B |
| C555 | 5A | R510 | 3A | R541 | 7A | | |

VOLUME TV-24, ADDITIONAL 1965 TELEVISION SERVICING INFORMATION

RCA Victor Chassis KCS-142AA, AC, R, Service Information, Continued

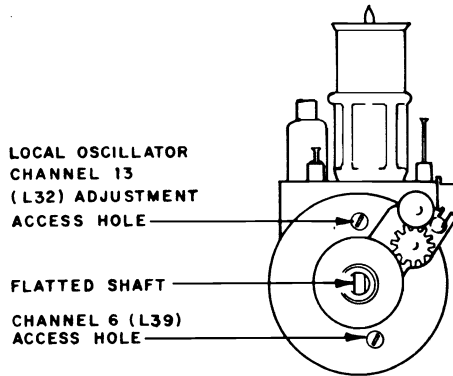

KRK114 VHF Oscillator Adjustment
(in Cabinet Procedure)

CABINET DISASSEMBLY NOTES

With AF095 Series instruments be certain to attach the back screw for the antenna block through the ground lug. This ground lug is required to properly terminate the monopole antenna.

To re-install the UHF knobs, the shaft must be in the extreme clockwise position and the inner (indicator) knob oriented so the line between number 83 and number 14 is adjacent the channel indicator mark on the cabinet. Then replace the outer knob.

A threaded stud is provided at the left edge of the chassis and may be used to mount the tuner assembly attaching it with one of the 1 1/32" nuts used to mount the assembly to the panel. For convenient servicing and for safety in transporting the chassis, it is recommended that this service position for the tuner assembly be utilized.

The picture tube is dismounted by completely loosening the Phillips head tension bolt located below the kinescope.

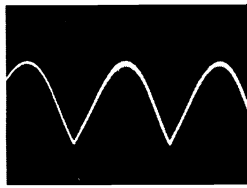

1 VERT. RATE 3.5 V P-P
TERM. B1-PW500
270V B+ BUS

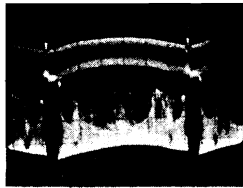

5 VERT. RATE 25 V P-P
TERM. N PW200
SYNC TAKE-OFF

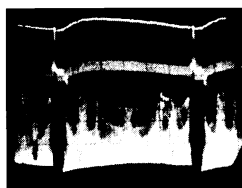

9 VERT. RATE 32 V P-P
TERM. D PW500
AGC GRID

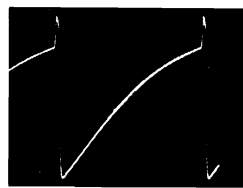

13 VERT. RATE 100 V P-P
V502A PIN 9
VERTICAL OSCILLATOR GRID

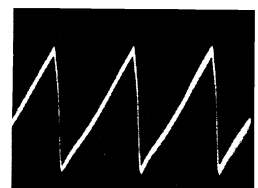

17 HORIZ. RATE 1 V P-P
ANODE SR501-C555
HORIZ. PHASE DETECTOR

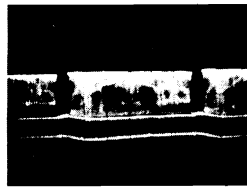

2 VERT. RATE 1.5 V P-P
2ND DETECTOR
TP3

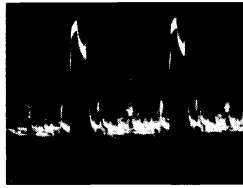

6 HORIZ. RATE 25 V P-P
TERM. N PW200
SYNC TAKE-OFF

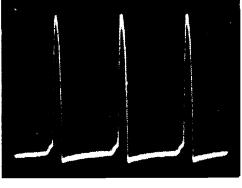

10 HORIZ. RATE 650 V P-P
TERM. A PW500
AGC PLATE

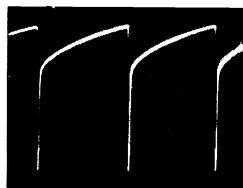

14 VERT. RATE 365 V P-P
V502B PIN 2
VERTICAL OUTPUT GRID

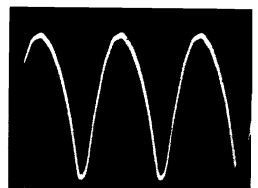

18 HORIZ. RATE 325 V P-P
PIN 4 J101 (YOKE SOCKET)
(B BOOST) HORIZ. YOKE WINDINGS



3 VERT. RATE 80 V P-P
V201B PIN 9
VIDEO AMPLIFIER PLATE

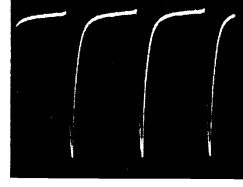

7 HORIZ. RATE 65 V P-P
V501B PIN 1
SYNC AMPLIFIER PLATE



11 HORIZ. RATE 165 V P-P
V101 PIN 6
HORIZONTAL OUTPUT GRID



15 VERT. RATE 110 V P-P
PIN 1 J101 (YOKE SOCKET)
VERT. OUTPUT TRANS. SEC.

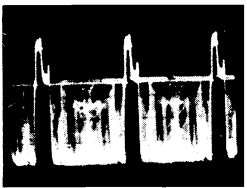

4 HORIZ. RATE 80 V P-P
V201B PIN 9
VIDEO AMPLIFIER PLATE

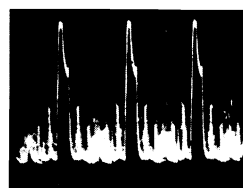

8 HORIZ. RATE 32 V P-P
TERM. D PW500
AGC GRID

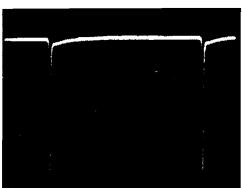

12 VERT. RATE 80 V P-P
PIN 2 V105
KINESCOPE GRID

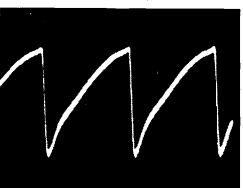

16 HORIZ. RATE 10 V P-P
CATHODE JUNCTION SR501
HORIZONTAL PHASE DETECTOR

Waveforms taken with Normal Signal Level Input, and 120V AC Power Supply

RCA Victor Chassis KCS-142R Schematic Diagram

KRK114/120 CIRCUIT SCHEMATIC DIAGRAM

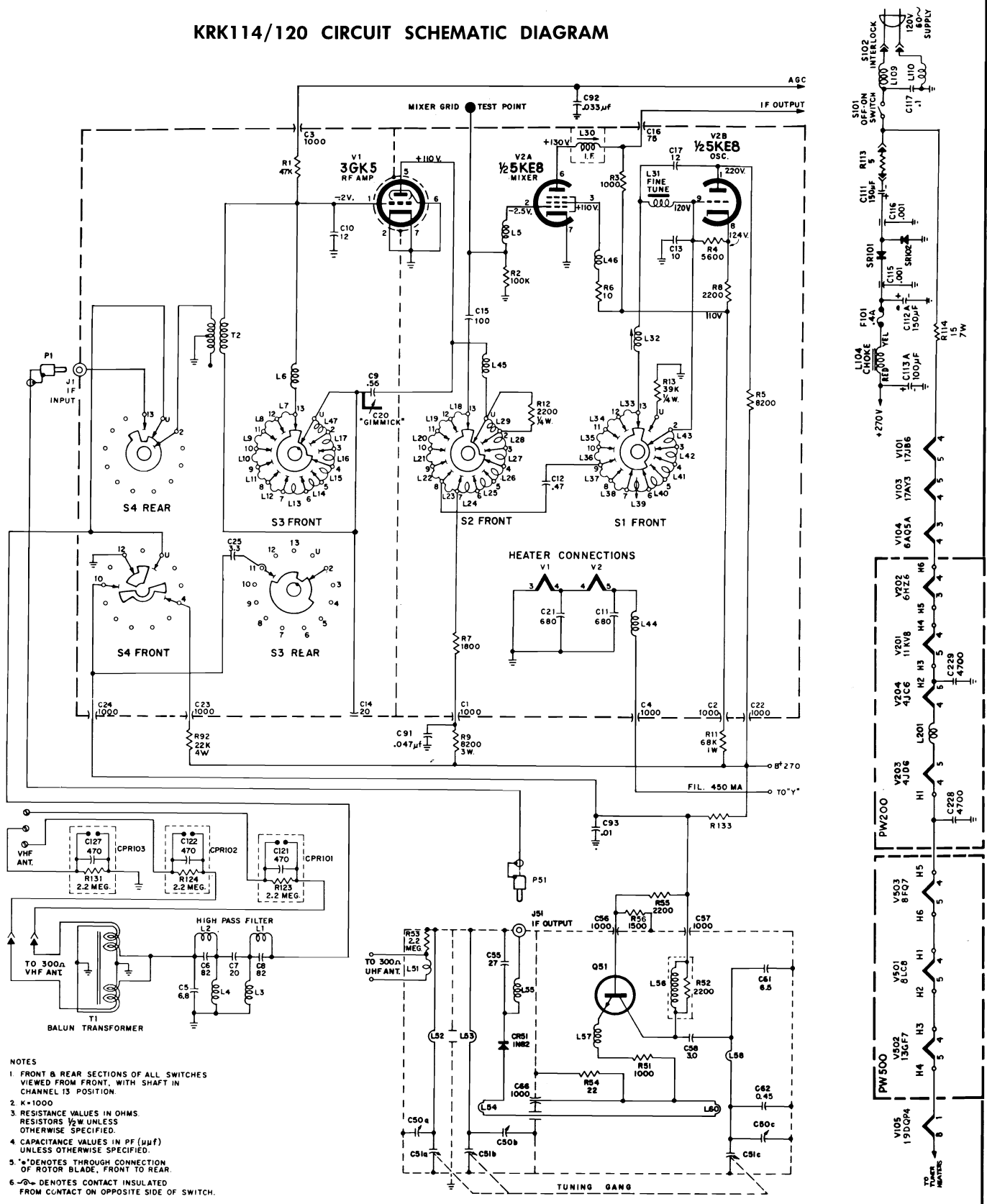

- NOTES
1. FRONT & REAR SECTIONS OF ALL SWITCHES VIEWED FROM FRONT, WITH SHAFT IN CHANNEL 13 POSITION.
 2. K=1000
 3. RESISTANCE VALUES IN OHMS. RESISTORS 1/2 W UNLESS OTHERWISE SPECIFIED.
 4. CAPACITANCE VALUES IN PF ($\mu\mu\text{f}$) UNLESS OTHERWISE SPECIFIED.
 5. * DENOTES THROUGH CONNECTION OF ROTOR BLADE, FRONT TO REAR.
 6. --- DENOTES CONTACT INSULATED FROM CONTACT ON OPPOSITE SIDE OF SWITCH.

VOLUME TV-24, ADDITIONAL 1965 TELEVISION SERVICING INFORMATION

RCA Victor Chassis KCS-142R Schematic Diagram, Continued

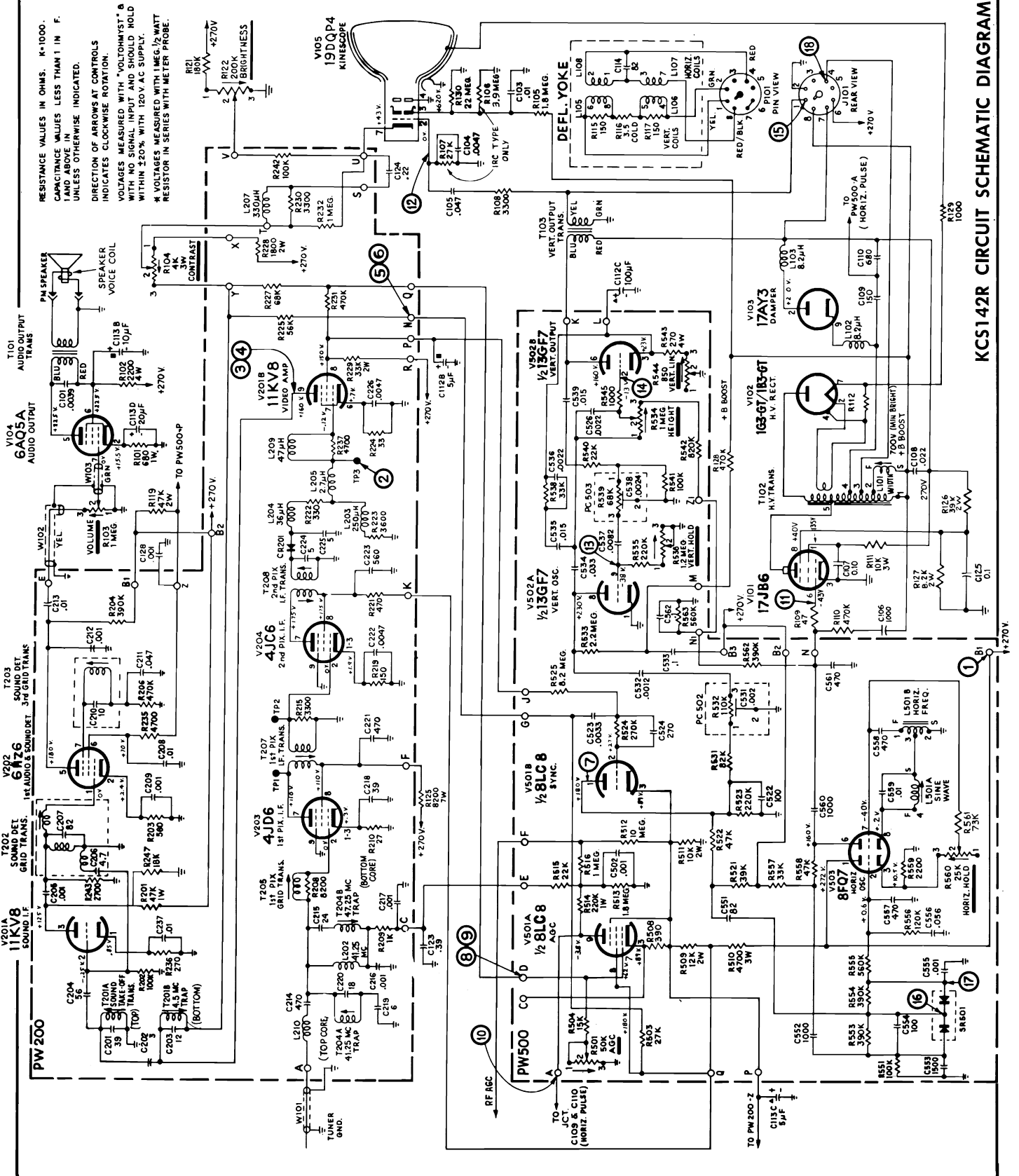

RESISTANCE VALUES IN OHMS. K=1000.
CAPACITANCE VALUES LESS THAN 1 IN F.
1 AND ABOVE IN P.
UNLESS OTHERWISE INDICATED.
DIRECTION OF ARROWS AT CONTROLS
INDICATES CLOCKWISE ROTATION.
VOLTAGES MEASURED WITH "VOLTOHMST" &
WITH NO SIGNAL INPUT AND SHOULD HOLD
WITHIN 10% WITH 120V AC SUPPLY.
* VOLTAGES MEASURED WITH 1MEG. 1/2 WATT
RESISTOR IN SERIES WITH METER PROBE.

KCS142R CIRCUIT SCHEMATIC DIAGRAM

RCA VICTOR

Chassis KCS 136X Series

MODEL AND CHASSIS REFERENCE

| MODEL | CHASSIS | TUNER MOUNTING ASSEMBLY | VHF/UHF TUNER | KINESCOPE | NAME |
|------------------|-----------|-------------------------|--------------------------|-----------|--------------|
| BF-211E, M, W, Y | KCS136XC | 60A | KRK118C/KRK120JP, KP, LP | 23ENP4 | "DAVIS" |
| BF-211MR, WR | KCS136XE* | 61A | KRK116B/KRK120JP, KP, LP | 23ENP4 | "DAVIS" |
| BF-213E, M, W, Y | KCS136XD | 60C | KRK118C/KRK120JP, KP, LP | 23ENP4 | "GARVEY" |
| CF-265M, W, Y | KCS136XC | 60A | KRK118C/KRK120JP, KP, LP | 23ENP4 | "BLAINE" |
| CF-265MR, WR, YR | KCS136XE* | 61A | KRK116B/KRK120JP, KP, LP | 23ENP4 | "BLAINE" |
| CF-270M, W, Y | KCS136XD | 60C | KRK118C/KRK120JP, KP, LP | 23ENP4 | "ARLEN" |
| CF-273W | KCS136XD | 60C | KRK118C/KRK120JP, KP, LP | 23ENP4 | "NORSTAD" |
| CF-274L | KCS136XD | 60C | KRK118C/KRK120JP, KP, LP | 23ENP4 | "TAUNTON" |
| CF-276V, W | KCS136XD | 60C | KRK118C/KRK120JP, KP, LP | 23ENP4 | "ORSINI" |
| CF-277C, F, V | KCS136XD | 60C | KRK118C/KRK120JP, KP, LP | 23ENP4 | "NORMAN" |
| CF-315M, W | KCS136XD | 60C | KRK118C/KRK120JP, KP, LP | 23ENP4 | "EVEREST" |
| CF-335M, W, Y | KCS136XD | 60C | KRK118C/KRK120JP, KP, LP | 23ENP4 | "CLEMENT" |
| CF-341M, W | KCS136XD | 60C | KRK118C/KRK120JP, KP, LP | 23ENP4 | "SULLIVAN" |
| CF-343M, W | KCS136XD | 60C | KRK118C/KRK120JP, KP, LP | 23ENP4 | "PORTLAND" |
| CF-345W | KCS136XD | 60C | KRK118C/KRK120JP, KP, LP | 23ENP4 | "OSLO" |
| CF-347L | KCS136XD | 60C | KRK118C/KRK120JP, KP, LP | 23ENP4 | "CHARTER" |
| CF-349V, W | KCS136XD | 60C | KRK118C/KRK120JP, KP, LP | 23ENP4 | "TORINO" |
| CF-351C, F, V | KCS136XD | 60C | KRK118C/KRK120JP, KP, LP | 23ENP4 | "BARBIZON" |
| CF-355M, W | KCS136XD | 60C | KRK118C/KRK120JP, KP, LP | 23ENP4 | "HUNTLEY" |
| CF-356W | KCS136XD | 60C | KRK118C/KRK120JP, KP, LP | 23ENP4 | "LINDON" |
| CF-357L | KCS136XD | 60C | KRK118C/KRK120JP, KP, LP | 23ENP4 | "HANCOCK" |
| CF-359M, W | KCS136XD | 60C | KRK118C/KRK120JP, KP, LP | 23ENP4 | "BRIERHURST" |
| CF-369M, W | KCS136XH | 70A | KRK118C/KRK120JT, KT, LT | 23FBP4 | "ABERDEEN" |
| CF-371W | KCS136XH | 70A | KRK118C/KRK120JT, KT, LT | 23FBP4 | "ELLESMERE" |
| CF-373L | KCS136XH | 70A | KRK118C/KRK120JT, KT, LT | 23FBP4 | "DARTMOUTH" |
| CF-375F, V | KCS136XH | 70A | KRK118C/KRK120JT, KT, LT | 23FBP4 | "LEMAIRE" |

*Remote Models use Remote Amplifier KRS28A and Remote Control Transmitter KRT4B.

| MODEL | NAME | CHASSIS | TMA | VHF/UHF TUNER | KINESCOPE |
|--------------|------------|----------|-----|---------------|-----------|
| CF263M, W | "BLENHEIM" | KCS136XD | 60C | KRK118C/120 | 23ENP4 |
| CF336M, W, Y | "HATHAWAY" | KCS136XD | 60C | KRK118C/120 | 23ENP4 |
| CF339M, W | "ASHTON" | KCS136XD | 60C | KRK118C/120 | 23ENP4 |

Service material below and on the next four pages. For alignment see material on pages 124-126 of TV-23, Early 1965 TV Manual.

CIRCUIT BREAKER

The B+ supply for this instrument is protected by a circuit breaker rather than a fuse. The reset button is located on the rear of the chassis and is accessible to the user. The circuit resets when the button is depressed and becomes operative when the button is released.

AGC AND SYNC STABILIZER

Turn the sync stabilizer control completely counterclockwise and adjust a.g.c. while tuned to a strong, local station. Turn the a.g.c. clockwise until picture begins to distort, and then counterclockwise slightly below the point where the distortion is eliminated. Advance the sync stabilizer fully clockwise and rotate the horizontal hold counterclockwise until horizontal sync is lost. Then slowly sync the picture again. If the picture tends to distort or "hang-up" before locking in, retard the sync stabilizer control until this condition is corrected.

ANTENNA

All models covered in this data are provided with 300 ohm balanced antenna input for both VHF and UHF. If a combined VHF/UHF antenna is to be used with a single transmission line, prepare a matching stub as illustrated in Figure 1, below.

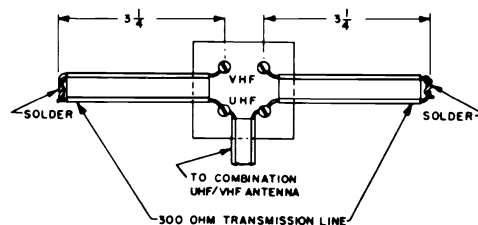

SERVICING PRECAUTIONS

WARNING: Operation of these receivers outside the cabinet or with the covers removed, involves a shock hazard from the receiver power supplies. Work on the receivers should not be attempted by anyone who is not thoroughly familiar with precautions necessary when working on high voltage equipment.

CAUTION: Do not install, remove, or handle the kinescope in any manner unless shatter-proof goggles are worn. People not so equipped should be kept away while handling kinescopes. Keep kinescope away from the body while handling.

Do not operate the receiver with the high voltage compartment shield open.

RCA Victor Chassis KCS-136X Tuner Diagram, Continued

KRK118/120 TUNER SCHEMATIC DIAGRAM

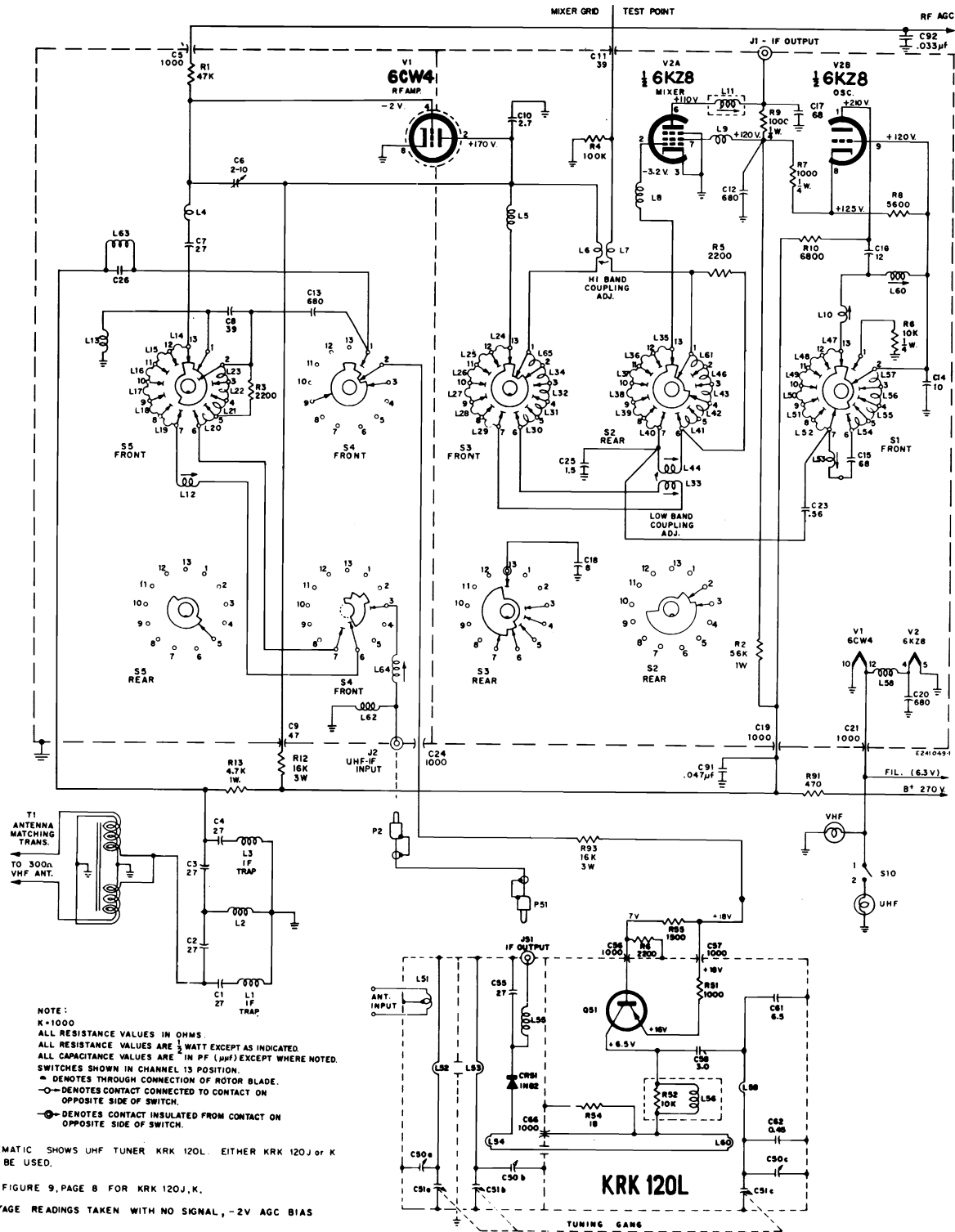

NOTE:
 K=1000
 ALL RESISTANCE VALUES IN OHMS.
 ALL RESISTANCE VALUES ARE 1/2 WATT EXCEPT AS INDICATED.
 ALL CAPACITANCE VALUES ARE IN PF (pF) EXCEPT WHERE NOTED.
 SWITCHES SHOWN IN CHANNEL 13 POSITION.
 — DENOTES THROUGH CONNECTION OF ROTOR BLADE.
 —○— DENOTES CONTACT CONNECTED TO CONTACT ON OPPOSITE SIDE OF SWITCH.
 —○— DENOTES CONTACT INSULATED FROM CONTACT ON OPPOSITE SIDE OF SWITCH.

SCHEMATIC SHOWS UHF TUNER KRK 120L. EITHER KRK 120J OR K BE USED.
 FIGURE 9, PAGE 8 FOR KRK 120J, K.
 *AGE READINGS TAKEN WITH NO SIGNAL, -2V AGC BIAS

KRK118/120 Tuner Schematic Diagram

VOLUME TV-24, ADDITIONAL 1965 TELEVISION SERVICING INFORMATION

RCA Victor Chassis KCS-136X Servicing Information, Continued

CENTERING

If the picture does not fill the screen, it may be necessary to center the picture with the 2 disc magnets mounted behind the yoke cover. Both horizontal and vertical centering are accomplished at once by rotating the discs together or separately. Perform this adjustment along with vertical height, vertical linearity, and width, as they are all interdependent.

TESTING PICTURE PROPORTIONS

Rotate the vertical blank control to roll the picture slowly downward and study the blanking bar. If it is not level, or if the bar varies in thickness as it moves down the screen, make adjustments as prescribed.

HEIGHT AND VERTICAL LINEARITY

If the blanking bar changed size while moving down, alternately adjust the height and vertical linearity controls for best vertical proportions. Final vertical size should allow the raster to overlap the mask about $\frac{3}{8}$ inch at top and bottom with normal (120 volts) line voltage.

WIDTH

The width adjustment is made with L101. With normal line voltage, the raster should overscan the mask about $\frac{3}{8}$ inch on each side. The raster should fill the mask at 108 volts.

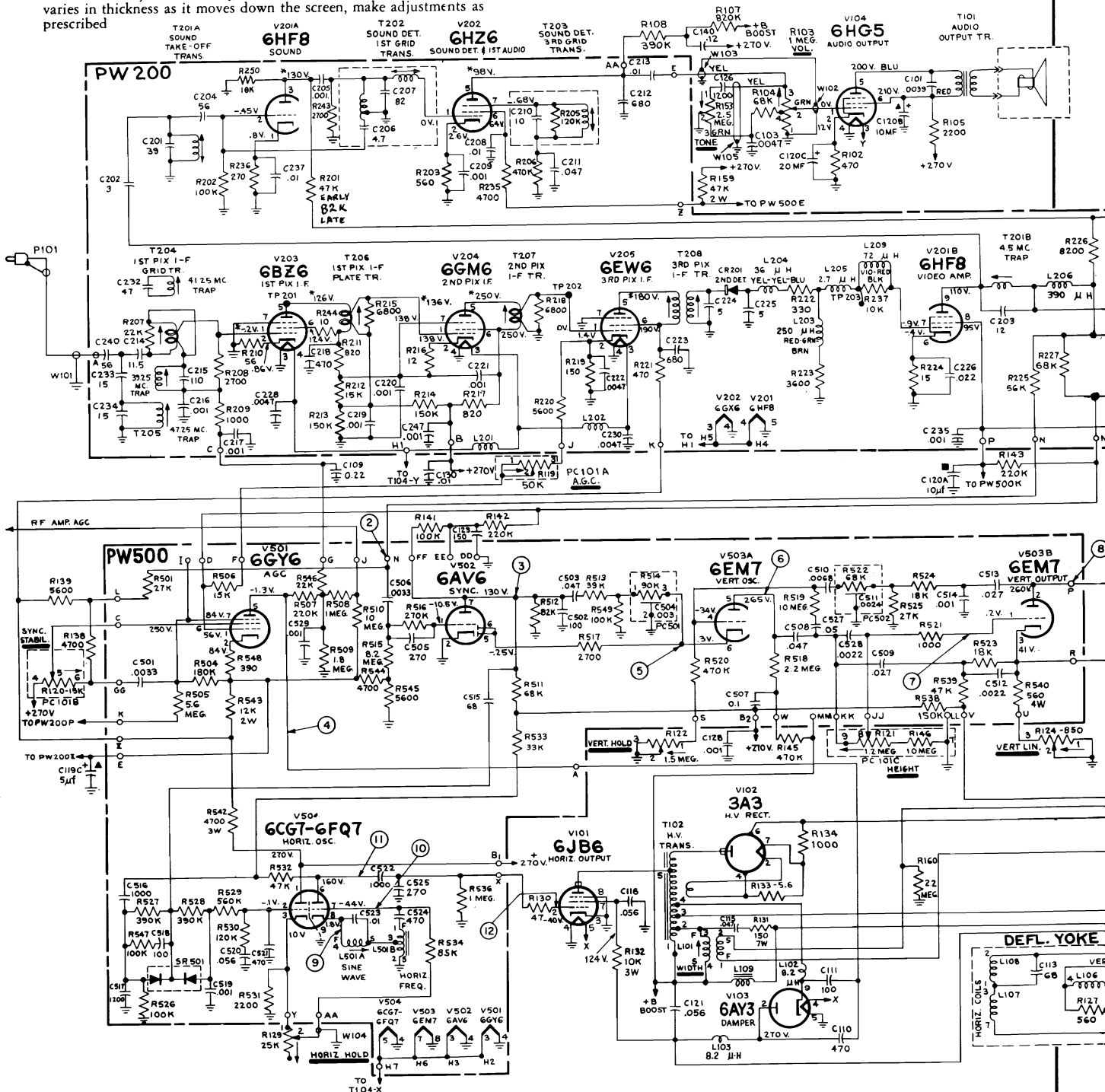

SCHEMATIC DIAGRAM FOR KCS136X CHASSIS

VOLUME TV-24, ADDITIONAL 1965 TELEVISION SERVICING INFORMATION

RCA Victor KCS-136X Board Views, Continued

PW200 SECURITY SEALED CIRCUIT ASSEMBLY

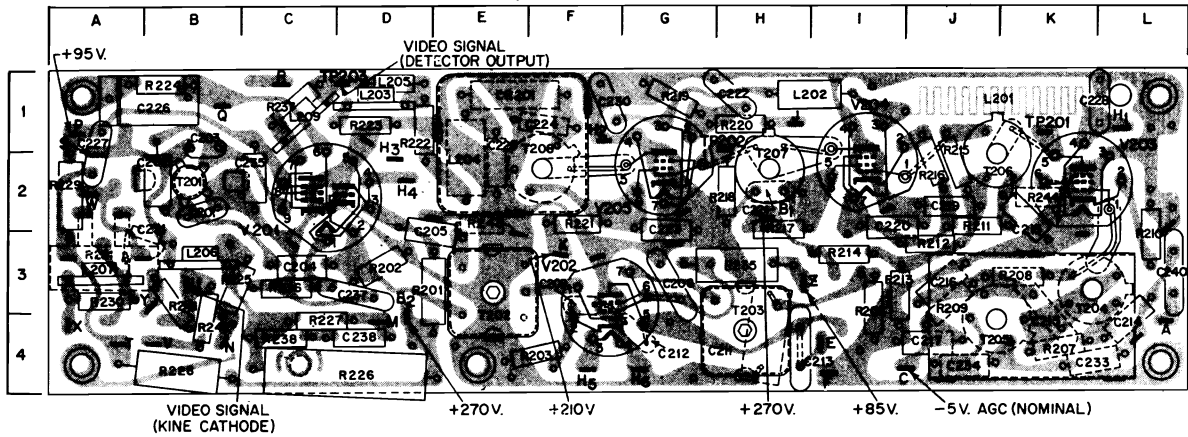

PW200 Sealed Circuit I-F and Video Assembly Composite Diagram

PW200 COMPONENT LOCATION GUIDE

| | | | | | | | |
|--------------|--------------|---------------|--------------|--------------|--------------|--------------|--------------|
| C2012B | C2163J | C2281L | L2021I | R2083K | R2191G | R2313A | T2034H |
| C2022B | C2174J | C2301F | L2031D | R2093I | R2201H | R2353H | T2043K |
| C2031B | C2182K | C2313B | L2042E | R2103L | R2212F | R2363C | T2054K |
| C2043C | C2192J | C2334L | L2051D | R2112J | R2221D | R2371C | T2062K |
| C2052D | C2202I | C2344J | L2063B | R2123J | R2231D | R2384C | T2072H |
| C2083G | C2212H | C2352C | L2073A | R2133I | R2241B | R2413B | T2082F |
| C2093F | C2221H | C2373D | L2091C | R2143I | R2253B | R2424B | |
| C2114H | C2232G | C2384D | R2013E | R2152J | R2264D | R2432E | |
| C2124G | C2241F | C2403L | R2023D | R2162J | R2274C | R2442K | |
| C2134H | C2252E | | R2034F | R2173H | R2284B | | |
| C2144L | C2261B | CR2011E | R2063I | R2182H | R2292A | T2012B | |
| C2154K | C2271A | L2011J | R2074K | | R2303A | T2023E | |

PW500 SECURITY SEALED CIRCUIT ASSEMBLY

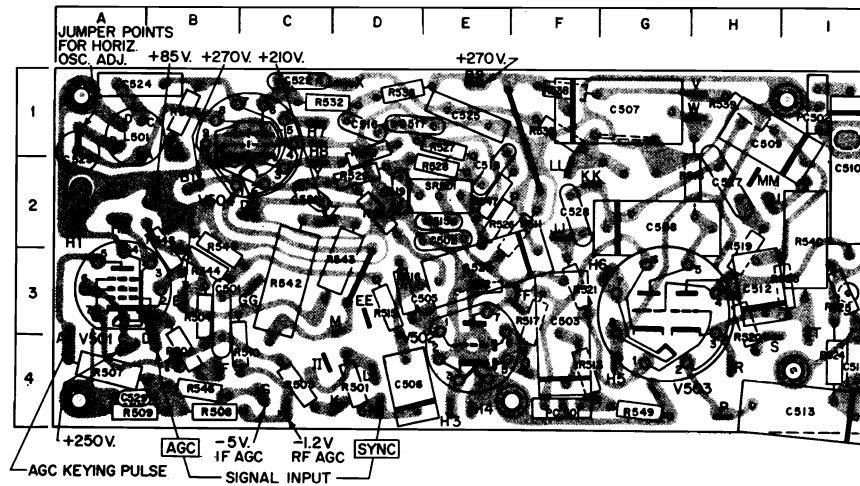

PW500 Sealed Circuit Deflection Assembly Composite Diagram

PW500 COMPONENT LOCATION GUIDE

| | | | | | | | |
|--------------|--------------|---------------|---------------|--------------|--------------|--------------|---------------|
| C5013B | C5134I | C5231A | PC5021I | R5112F | R5233I | R5331D | R5464B |
| C5022E | C5144I | C5241A | | R5123E | R5244I | R5341B | R5472E |
| C5033F | C5152E | C5251E | R5014D | R5134F | R5253I | R5361F | R5482B |
| C5053D | C5161D | C5272H | R5043B | R5153D | R5262E | R5381F | R5494G |
| C5064D | C5171D | C5282F | R5054C | R5163D | R5271E | R5391H | |
| C5071G | C5182E | C5294A | R5064B | R5173F | R5282E | R5402I | SR5012E |
| C5082G | C5192D | | R5074A | R5182H | R5292D | R5423C | |
| C5091H | C5203E | L5011A | R5084B | R5192H | R5302D | R5433D | |
| C5102I | C5212C | | R5094A | R5203H | R5311D | R5443B | |
| C5123H | C5221C | PC5014F | R5104C | R5213F | R5321C | R5452B | |

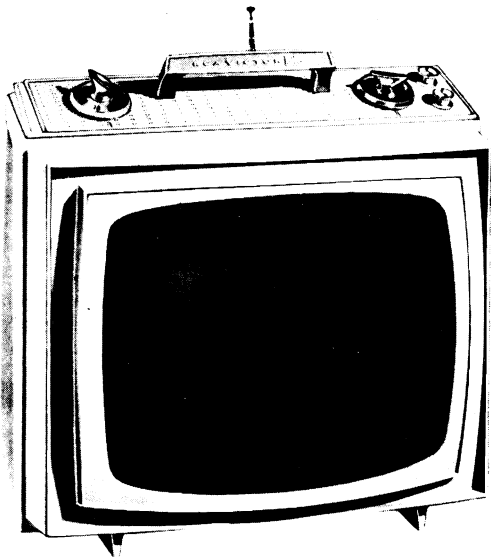

RCA VICTOR

| MODEL | CHASSIS |
|------------------|---------|
| AF-020J | KCS152A |
| AF-021E, H, T | KCS152A |
| AG-029A, B, E, N | KCS152C |

(Material on the next ten pages)

TESTING PICTURE PROPORTIONS

Rotate the vertical hold control to roll picture slowly downward and study the blanking bar. If it is not level, or if the bar varies in thickness as it moves down the screen, make adjustments as prescribed in the next two paragraphs.

DEFLECTION YOKE

If the picture is tilted, loosen the yoke clamp screw and rotate the yoke to level the picture. Retighten the yoke clamp.

WIDTH AND LINEARITY ADJUSTMENTS

Adjust the Vertical Height and Linearity controls for approximately symmetrical raster.

IMPORTANT: *Width adjustment must be made with low line, 108 VAC, supply voltage.*

Set brightness and contrast controls at maximum. Adjust R108, width control, until the raster just fills the screen horizontally $+0, -\frac{1}{8}$ ". Turn centering magnets individually and together to center the raster.

Turn contrast control to minimum, then center the raster vertically. After vertical height and linearity adjustments are completed at 108 VAC supply voltage, the raster should fill the screen $+0, -\frac{1}{4}$ " at the top and bottom.

If the vertical height and linearity controls are correctly set, the raster will fill the screen the proper amount at 120 VAC supply voltage and the blanking bar will not change in width as the picture is rolled vertically.

AGC AND SYNC

The AGC and SYNC are dependent upon the proper width control adjustment.

The width control should not be changed from correct width adjustment in order to influence AGC.

HORIZONTAL SINE WAVE ADJUSTMENT

Remove sync by shorting Terminal "AE" (Zone A-6, PW200) to chassis ground. Short sine wave coil L207 by connecting a jumper wire between TP4 and Terminal "W" (Both in Zone F-6, PW200).

Adjust horizontal hold control until picture sides are vertical. Remove short from sine wave coil (TP-4 and Terminal "W"), then adjust L207 sine wave coil so that the picture remains stationary with sides vertical. Remove short from sync (Terminal "AE").

From CCW direction of horizontal hold control, pull in from out of sync condition should be from 1 to 3 bars. From the CW direction from 1 to 8 bars. There should be no loss of raster on either extreme of control rotation.

SET DETENT
TO CHANNEL 13

LOCAL OSCILLATOR
CHANNEL 13
ADJUSTMENT
ACCESS
HOLE

FLATTED
SHAFT

CHANNEL 6
ACCESS
HOLE

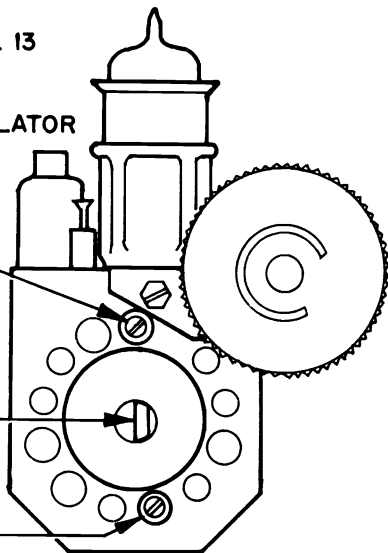

VHF LOCAL OSCILLATOR ADJUSTMENT (In-Cabinet Procedure)

Set fine tuning to approximate center of its range, turn tuner to highest channel that can be received in the high VHF band (Channels 7-13). Remove VHF tuning knob, and adjust L32 for best picture and sound. Without disturbing fine tuning, turn to highest channel available locally in the low band (Channels 2-6). Adjust L39 for best sound and picture. Fine tuning range is broad enough so that all local stations can be tuned with the local oscillator set for the highest channel in the respective bands.

CENTERING

If the picture is not positioned correctly on the screen, it may be necessary to center the picture with the two disc magnets mounted behind the yoke cover. Both horizontal and vertical centering are accomplished at once by rotating the discs together or separately. Perform this adjustment along with vertical height, vertical linearity, and width, as they are all interdependent.

RCA Victor KCS-152A Printed Board View, Continued

PW200 SECURITY SEALED CIRCUIT ASSEMBLY

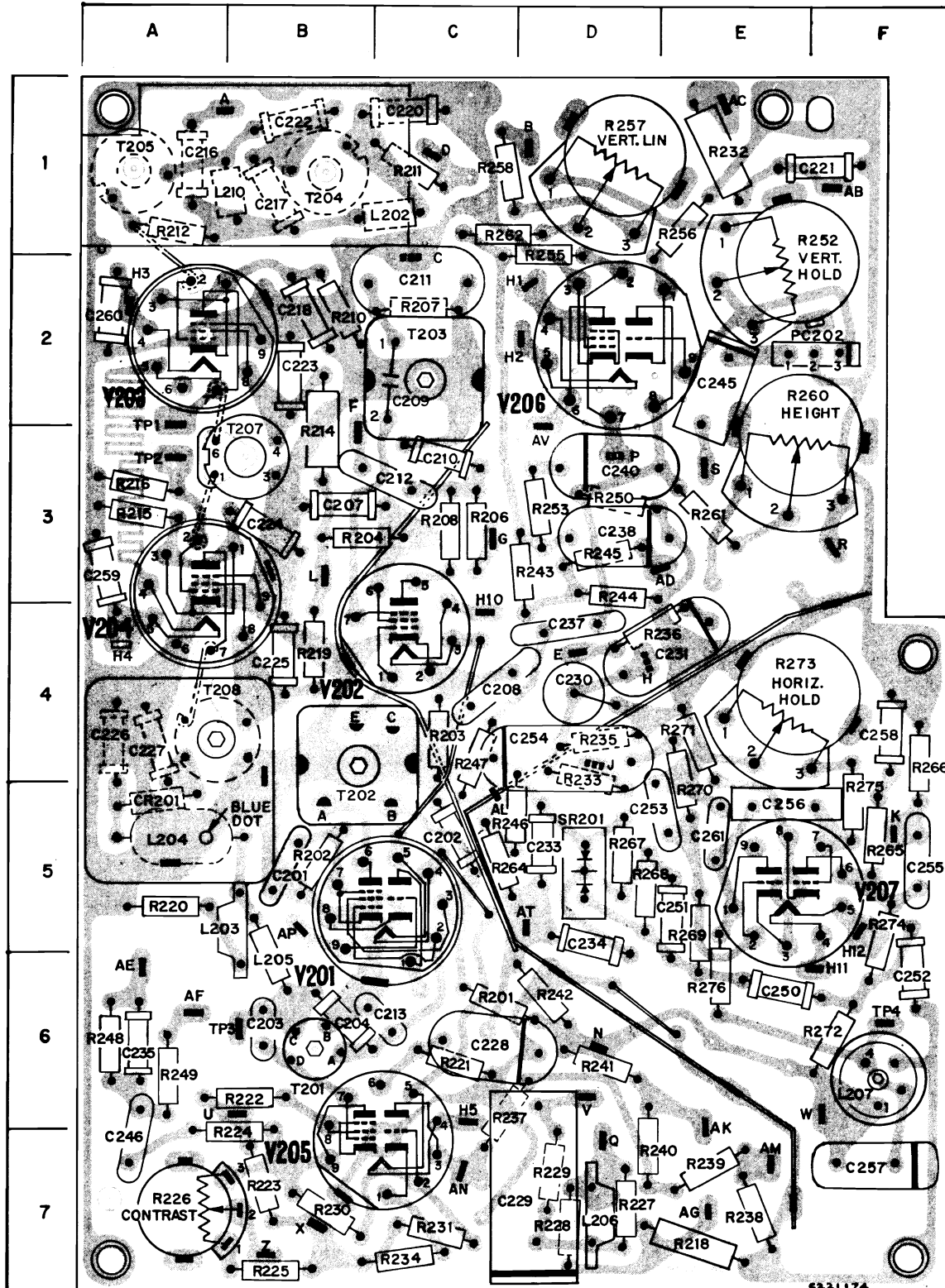

VOLUME TV-24, ADDITIONAL 1965 TELEVISION SERVICING INFORMATION

KCS152 CHASSIS LAYOUT

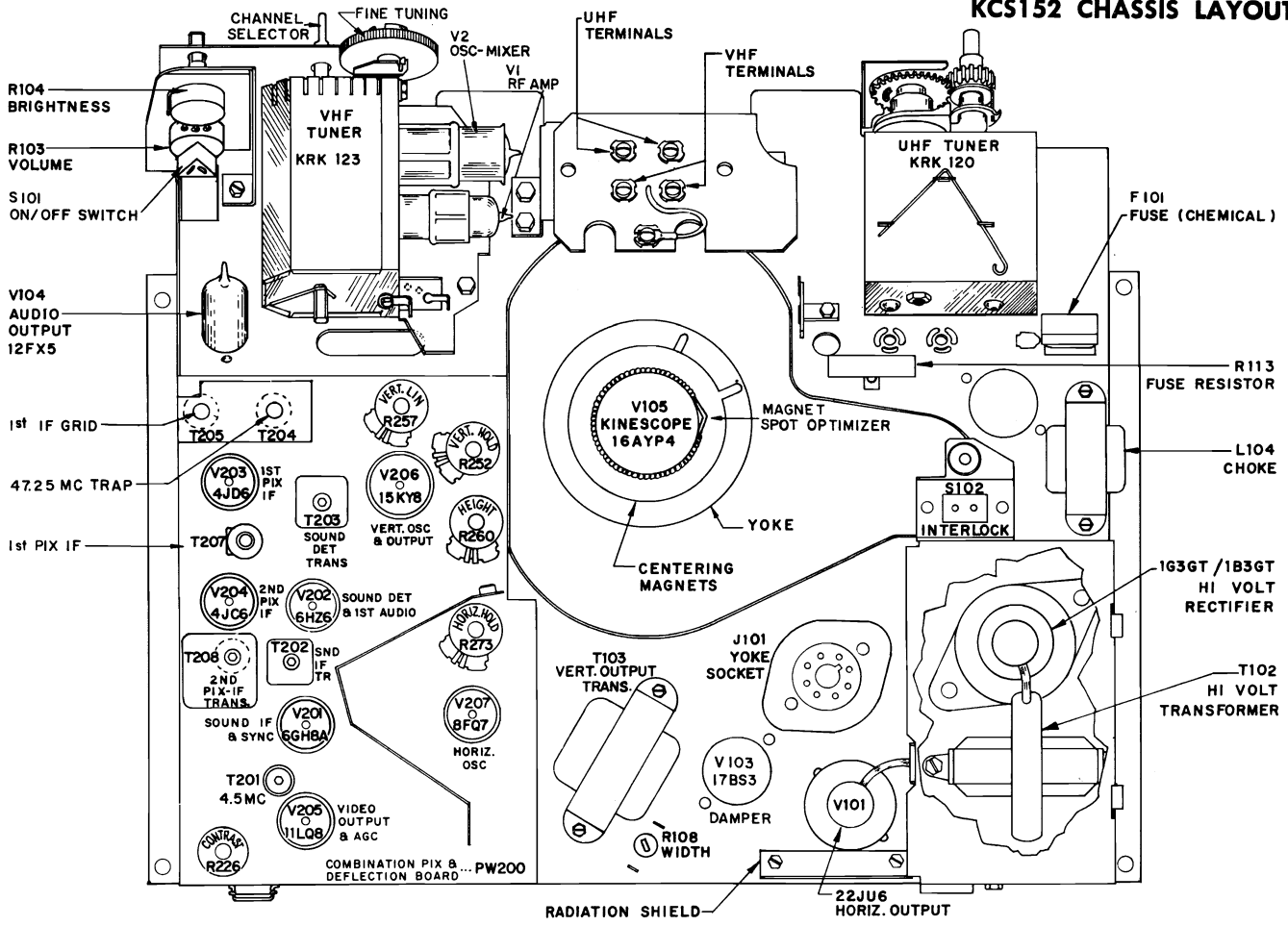

PW200—COMPONENT LOCATION GUIDE

| | | | | | | | | | | | | | | | |
|------|----|------|----|-------|----|-------|----|------|----|------|----|------|----|-------|----|
| C201 | B5 | C221 | F1 | C241 | F2 | L202 | C1 | R212 | A1 | R231 | C7 | R248 | A6 | R268 | D5 |
| C202 | C5 | C222 | B1 | C244 | F2 | L203 | A5 | R214 | B3 | R232 | E1 | R249 | A6 | R269 | E5 |
| C203 | B6 | C223 | B2 | C245 | E2 | L204 | A5 | R215 | A3 | R233 | D4 | R250 | D3 | R270 | E5 |
| C204 | B6 | C224 | B3 | C246 | A7 | L205 | B6 | R216 | A3 | R234 | C7 | R252 | F1 | R271 | E4 |
| C205 | B5 | C225 | B4 | C250 | E6 | L206 | D7 | R218 | E7 | R235 | D4 | R253 | D3 | R272 | F6 |
| C207 | B3 | C226 | A4 | C251 | E5 | L207 | F6 | R219 | B4 | R236 | E4 | R254 | F2 | R273 | E4 |
| C208 | C4 | C227 | A4 | C252 | F6 | L210 | B1 | R220 | A5 | R237 | C6 | R255 | D2 | R274 | F5 |
| C209 | C2 | C228 | C6 | C253 | D5 | PC202 | F2 | R221 | C6 | R238 | E7 | R256 | E1 | R275 | F5 |
| C210 | C3 | C229 | C7 | C254 | D4 | R201 | C6 | R222 | A6 | R239 | E7 | R257 | D1 | R276 | E6 |
| C211 | C2 | C230 | D4 | C255 | F5 | R202 | B5 | R223 | B7 | R240 | D7 | R258 | C1 | SR201 | D5 |
| C212 | C3 | C231 | E4 | C256 | E5 | R203 | C4 | R224 | A7 | R241 | D6 | R260 | F2 | T201 | B6 |
| C213 | C6 | C233 | D5 | C257 | E7 | R204 | B3 | R225 | B7 | R242 | D6 | R261 | E3 | T202 | B5 |
| C214 | B5 | C234 | D5 | C258 | F4 | R206 | C3 | R226 | A7 | R243 | D3 | R262 | C1 | T203 | C2 |
| C216 | A1 | C235 | A6 | C259 | A3 | R207 | C2 | R227 | D7 | R244 | D3 | R264 | C5 | T204 | B1 |
| C217 | B1 | C237 | D4 | C260 | A2 | R208 | C3 | R228 | D7 | R245 | D3 | R265 | F5 | T205 | A1 |
| C218 | B2 | C238 | D3 | C261 | E5 | R210 | B2 | R229 | D7 | R246 | C5 | R266 | F4 | T207 | B3 |
| C220 | C1 | C240 | D3 | CR201 | A5 | R211 | C1 | R230 | B7 | R247 | C4 | R267 | D5 | T208 | A4 |

PW200—TEST POINT LOCATION GUIDE

| | | | | | | | | | | | | | | | |
|----|----|----|----|----|----|---|----|-----|----|-----|----|-----|----|-----|----|
| A | A1 | AG | E7 | AV | D2 | E | B4 | H1 | D2 | H11 | F6 | P | D3 | TP3 | A6 |
| A | B5 | AK | E7 | B | D1 | E | D4 | H2 | D2 | H12 | F5 | Q | D7 | TP4 | F6 |
| AB | F1 | AL | C5 | B | C5 | E | B7 | H3 | A2 | J | D4 | R | F3 | U | B6 |
| AC | E1 | AM | E7 | C | C2 | F | B2 | H4 | A4 | K | F5 | S | E3 | V | C6 |
| AD | E3 | AN | B7 | C | B4 | G | C3 | H5 | C6 | L | B3 | TP1 | A3 | W | F6 |
| AE | A6 | AP | B5 | D | C1 | H | E4 | H10 | C4 | N | C6 | TP2 | A3 | X | B7 |
| AF | A6 | AT | D5 | | | | | | | | | | | | |

VOLUME TV-24, ADDITIONAL 1965 TELEVISION SERVICING INFORMATION

RCA Victor KCS-152A Waveform Information, Continued

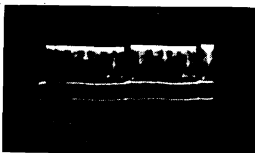

VERT. RATE 1.5V P-P
SECOND DETECTOR
TP-3

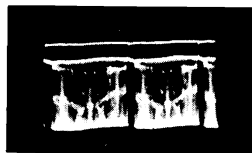

VERT. RATE 90V P-P
V205B PIN 9
VIDEO AMPLIFIER PLATE

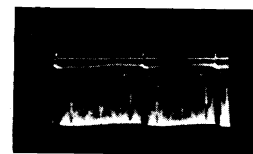

VERT. RATE 90V P-P
R224 & C246 JUNCTION
(ZONE 7A PW200 BOARD)

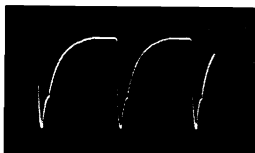

HORIZ. RATE 110V P-P
V101 PINS 2 & 6
HORIZONTAL OUTPUT GRID

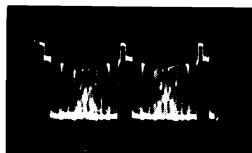

HORIZ. RATE 90V P-P
V205B PIN 9
VIDEO AMPLIFIER PLATE

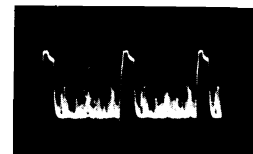

HORIZ. RATE 90V P-P
R224 & C246 JUNCTION
(ZONE 7A PW200 BOARD)

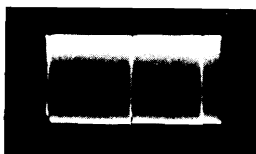

VERT. RATE 65V P-P
V201B PIN 1
SYNC PLATE



VERT. RATE 40V P-P
V205A PIN 2
AGC GRID

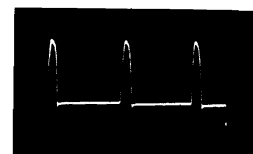

HORIZ. RATE 360V P-P
V205A PIN 3
AGC PLATE



HORIZ. RATE 65V P-P
V201B PIN 1
SYNC PLATE



HORIZ. RATE 40V P-P
V205A PIN 2
AGC GRID

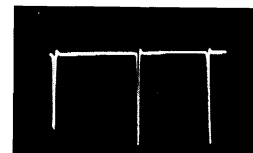

VERT. RATE 60V P-P
V105 PIN 2
KINESCOPE GRID

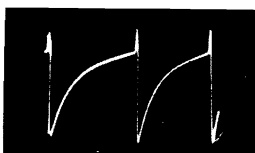

VERT. RATE 140V P-P
V206B PIN 9
VERTICAL OSCILLATOR GRID



VERT. RATE 12V P-P
SR201 CATHODE JUNCTION
HORIZONTAL PHASE DETECTOR



VERT. RATE 12V P-P
SR201 ANODE
HORIZONTAL PHASE DETECTOR

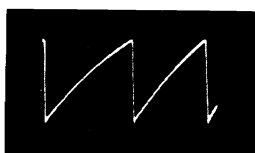

VERT. RATE 25V P-P
V206A PIN 2
VERTICAL OUTPUT GRID

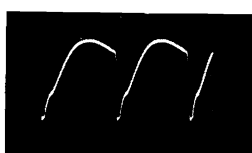

HORIZ. RATE 12V P-P
SR201 CATHODE JUNCTION
HORIZONTAL PHASE DETECTOR

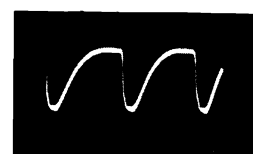

HORIZ. RATE 12V P-P
SR201 ANODE
HORIZONTAL PHASE DETECTOR

KCS152 WAVEFORMS

VOLUME TV-24, ADDITIONAL 1965 TELEVISION SERVICING INFORMATION

RCA Victor KCS-152A, Tuner Circuit, Continued

KRK123A/120JU CIRCUIT SCHEMATIC DIAGRAM

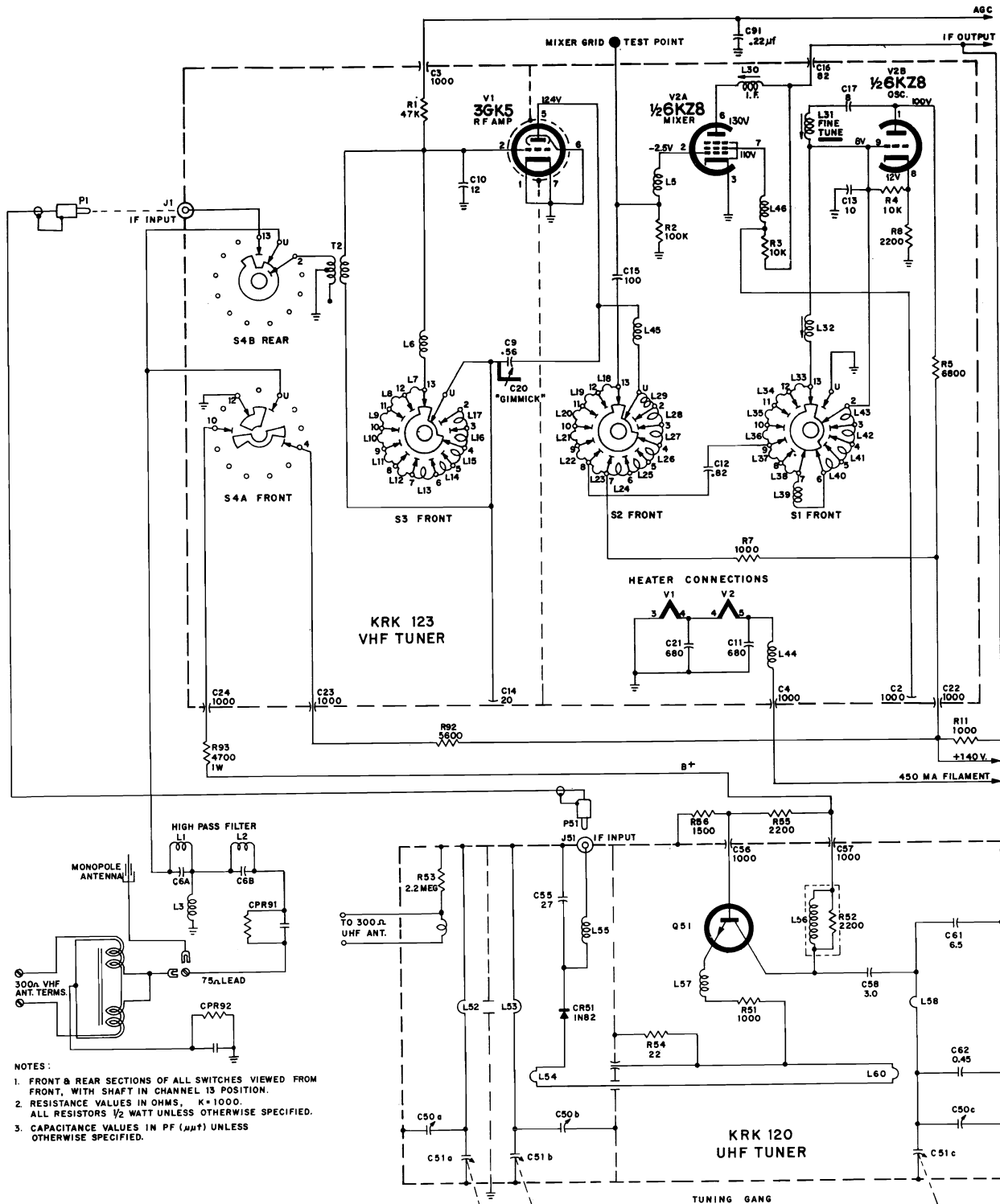

- NOTES:
1. FRONT & REAR SECTIONS OF ALL SWITCHES VIEWED FROM FRONT, WITH SHAFT IN CHANNEL 13 POSITION.
 2. RESISTANCE VALUES IN OHMS, K=1000. ALL RESISTORS 1/2 WATT UNLESS OTHERWISE SPECIFIED.
 3. CAPACITANCE VALUES IN PF (μ F) UNLESS OTHERWISE SPECIFIED.

VOLUME TV-24, ADDITIONAL 1965 TELEVISION SERVICING INFORMATION

RCA Victor Chassis KCS-152A Alignment Information, Continued

PICTURE I-F ALIGNMENT — KCS152 CHASSIS

PICTURE I-F TRANSFORMER AND TRAP ADJUSTMENTS

TEST EQUIPMENT CONNECTIONS:

BIAS SUPPLY..... In step 1 ground I-F AGC terminal "D" of PW200. In step 2 use —5 volts bias to I-F AGC terminal "D" during trap adjustment.

MARKER GENERATOR..... Connect to Mixer Grid test point of KRK123 in series with pad shown in illustration.

VTVM..... Connect direct probe to TP3 (2nd Detector).

MISCELLANEOUS..... Connect a 300 ohm carbon resistor as a dummy load across the antenna terminals. Refer to illustration for all adjustment locations and responses.

PEAK ALIGNMENT

| STEP | SWEEP GENERATOR | MARKER GENERATOR | ADJUST | REMARKS | |
|------|------------------------------|------------------|-----------|---------|--|
| 1 | Peak 1st Pix IF Plate Trans. | NOT USED | 44.25 mc. | T207 | Peak T207 and adjust Marker Generator output for approximately 3 volts at TP3 when finally peaked. |
| 2 | Adjust 47.25 mc. Trap | | 47.25 mc. | T204 | Adjust T204 for minimum. |

PICTURE I-F SWEEP ALIGNMENT

TEST EQUIPMENT CONNECTIONS:

BIAS SUPPLY..... —5 volts to term "D" of PW200.

OSCILLOSCOPE..... Direct probe to TP3. Calibrate scope for 5 volts peak to peak.

MARKER GENERATOR..... Connect to Mixer Grid test point of KRK123 in series with matching pad shown in illustration.

SWEEP GENERATOR..... Connect to TP2 (pin 2 of 4JC6). Use short leads.

| STEP | SWEEP GENERATOR | MARKER GENERATOR | ADJUST | REMARKS | |
|---|--|------------------|--|---------------------------|--|
| 3 | Adjust 2nd Picture I-F plate Transformer | 40-50 mc. | 41.25 mc. 45.75 mc. | T208 (Top & Bottom Cores) | Adjust for maximum gain and response curve "A". Reduce sweep gain to maintain 5 V P-P. |
| Move the OSCILLOSCOPE to TP1 using a diode probe and 180 ohm pad. Calibrate the oscilloscope for 0.5 volts Peak to Peak. Sweep Generator to Mixer Grid TP. Lightly couple Marker to sweep cable. Channel selector to 3 (—5 V AGC Bias). | | | | | |
| 4 | Adjust tuner I-F and 1st I-F grid Transformer | 40-50 mc. | 41.25 mc. 45.75 mc. | L30 T205 | Adjust for response "B". Use inner peak of L30 coil slug (bottom of winding). |
| 4A | Remove AGC from TP terminal "D". Ground terminal "D". Reduce sweep and retouch L30 for response "C" (zero bias check). | | | | |
| Use direct probe and connect oscilloscope to TP3. Calibrate to 5 volts Peak to Peak. Remove 180 ohm pad. Set bias at —5 volts. | | | | | |
| 5 | Check I-F Overall | 40-50 mc. | 41.25 mc. 45.75 mc. | T207 | Retouch T207 slightly to maintain response "D". |
| Remove dummy antenna load and substitute the sweep attenuator pad. Attach the sweep generator to the attenuator pad. The Marker Generator to tuner TP through pad shown. | | | | | |
| 6 | Check RF/I-F Overall | 40-50 mc. | 41.25 mc. 42.5 mc. 45.0 mc. 45.75 mc. | T207 | Make slight adjustments only. Observe response "E". |

VOLUME TV-24, ADDITIONAL 1965 TELEVISION SERVICING INFORMATION

RCA Victor Chassis KCS-152A Alignment Information, Continued

KCS152 CHASSIS IF ALIGNMENT

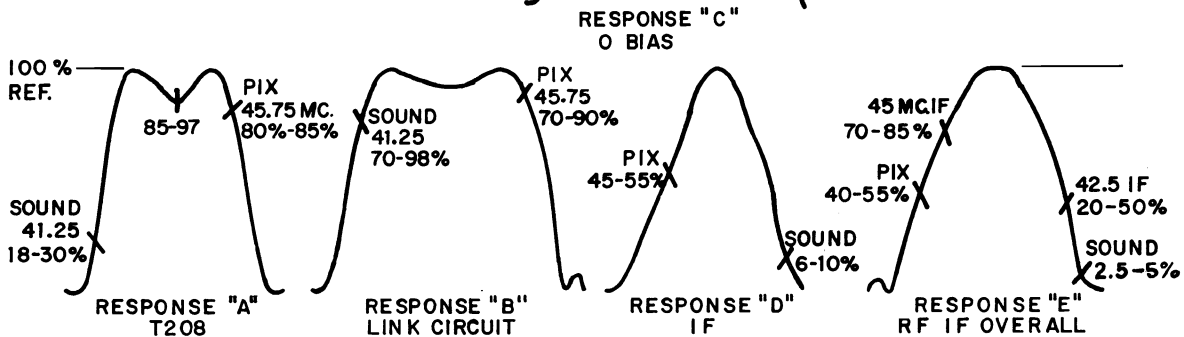
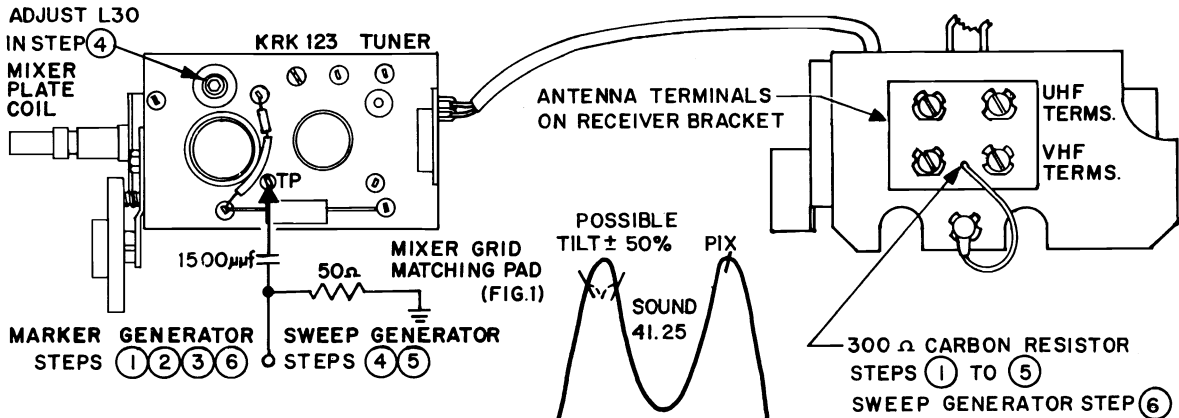
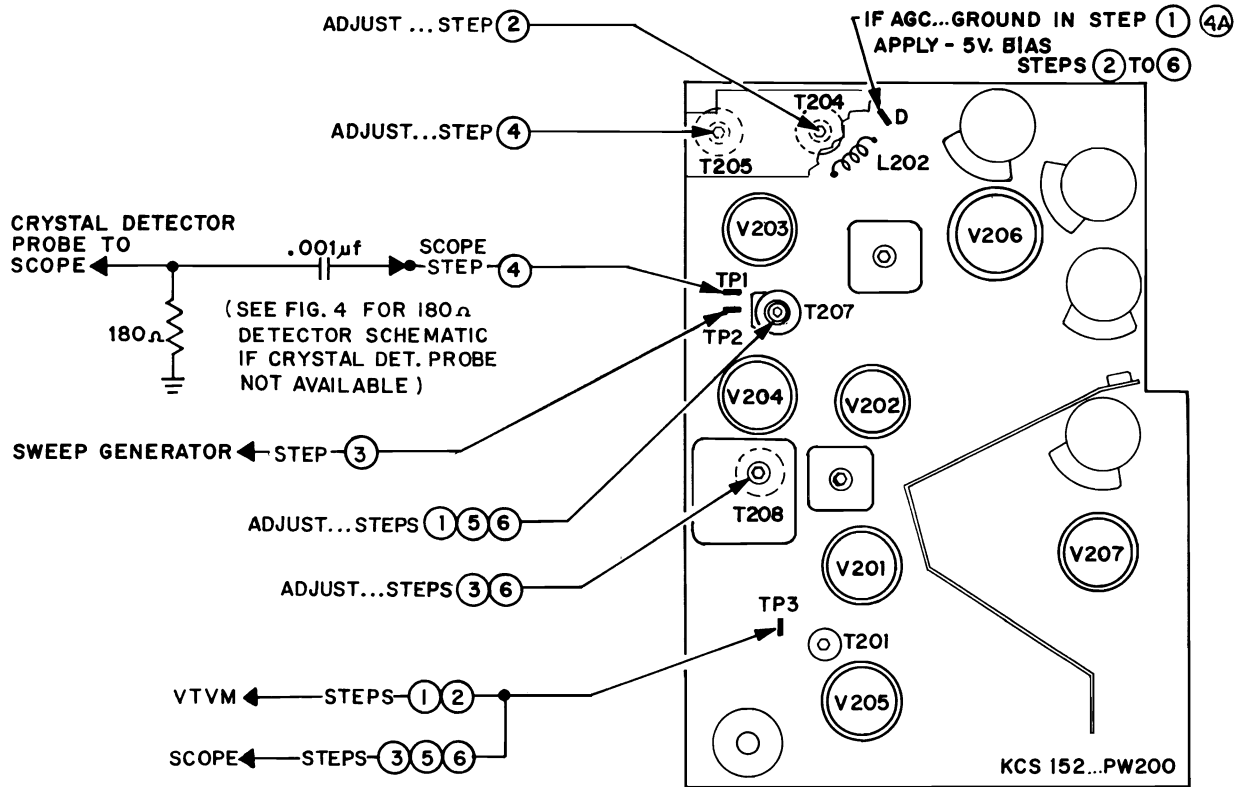

RCA Victor
KCA-152A
Diagram

RCA Victor KCS-152A Schematic Diagram, Continued

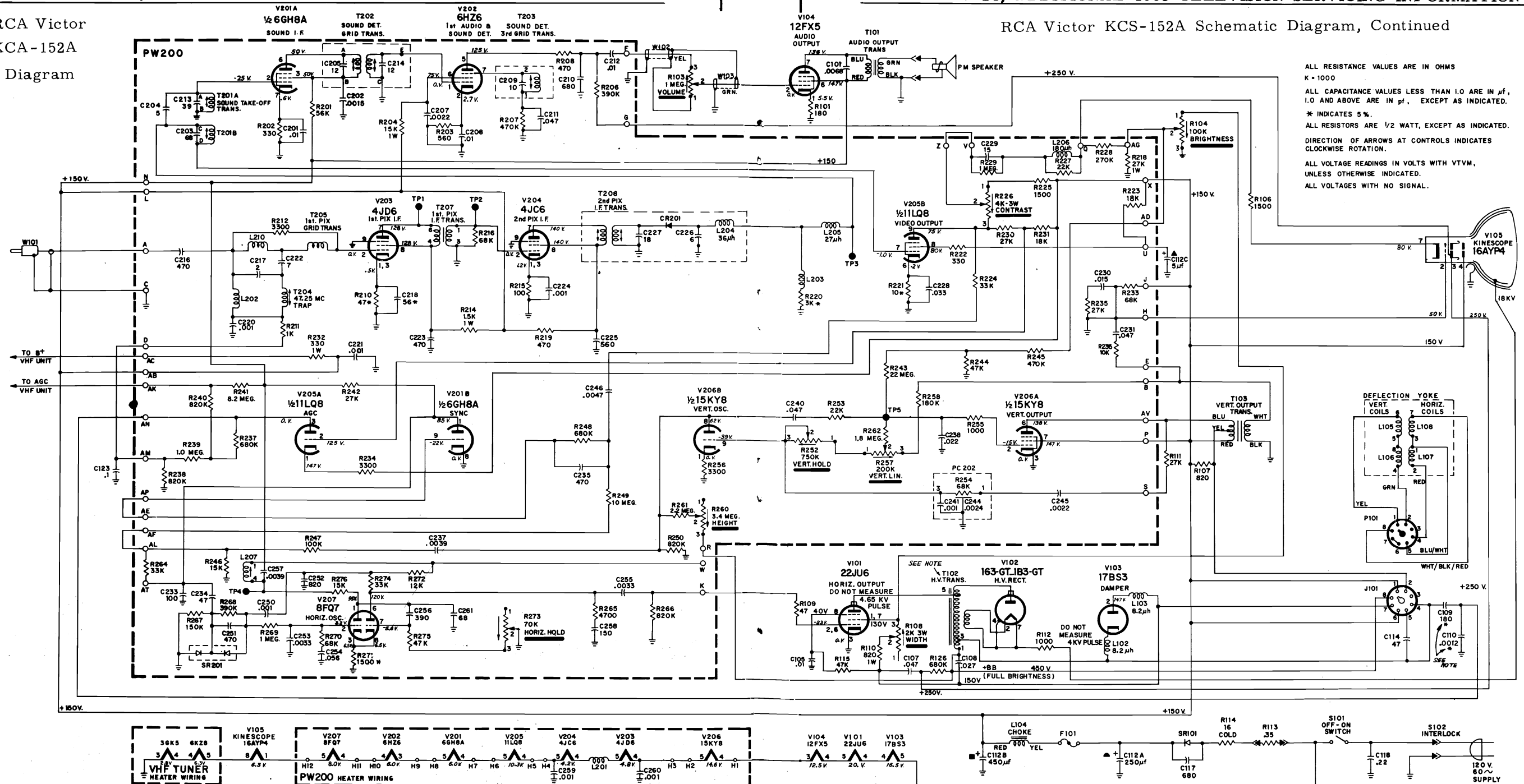

ALL RESISTANCE VALUES ARE IN OHMS
K = 1000
ALL CAPACITANCE VALUES LESS THAN 1.0 ARE IN μ F.
1.0 AND ABOVE ARE IN pf., EXCEPT AS INDICATED.
* INDICATES 5%
ALL RESISTORS ARE 1/2 WATT, EXCEPT AS INDICATED.
DIRECTION OF ARROWS AT CONTROLS INDICATES
CLOCKWISE ROTATION.
ALL VOLTAGE READINGS IN VOLTS WITH VTVM,
UNLESS OTHERWISE INDICATED.
ALL VOLTAGES WITH NO SIGNAL.

KCS152 CHASSIS CIRCUIT SCHEMATIC DIAGRAM

SPOT OPTIMIZER MAGNET ADJUSTMENT

The spot optimizer magnet adjustment need be made only when a new kinescope is installed or the magnet has been moved.
To adjust the spot optimizer magnet:
Use a cross hatch or dot pattern and set brightness so that only cross hatch lines or dots are visible on the raster.
While observing the pattern in the center portion of the screen,

adjust the spot optimizer magnet for a symmetrical halo. Greatest effect of the magnet will be observed in the upper center section of the kinescope face.
If a dot-bar generator is not available the magnet may be adjusted as follows:
Turn the channel selector to a non-operating channel which displays the greatest amount of noise or "snow". While observing the snowy raster, adjust the spot optimizer for greatest detail in the center line portion of the screen.

NOTE:
with Transformer T102 marked 906183-501 RCA
Stock #114498 use:
C109 114478 cap. ceram., 150 pf, 5%, 5000v, N2200
C110 cap. ceram., 0.001 pf, 5%, 500v
with Transformer T102 marked 906195-501 RCA
Stock #114714 use:
C109 114715 cap. ceram., 180 pf, 5%, 5000v, N2200
C110 114726 cap. ceram., 0.0012 mf, 5%, 500v, N3300

CHASSIS REMOVAL AND SAFETY GLASS CLEANING

The knobs must be removed from the brightness control, the volume control, the VHF tuner shaft, and the UHF tuner shaft in order to remove the chassis.
To disassemble the instrument, remove the six screws from the back (top and bottom), the screw at the AC power cord input, and the screw just below the VHF antenna input terminals. Disconnect the antenna and remove the back. The chassis and tuners are removed as a unit. Remove the four hex-head fasteners above and below the chassis. Disconnect the yoke plug and the two speaker pin plugs at the speaker. Remove the chassis partially and disconnect the second anode.
To remove the kinescope, loosen the long compression bolt which secures the mounting strap of the kinescope. It is not necessary to remove the bolt entirely to free the kinescope.

SOUND I-F ALIGNMENT OF KCS151 CHASSIS
SOUND I-F, SOUND DETECTOR AND 4.5 MC. TRAP ALIGNMENT

TEST EQUIPMENT CONNECTIONS:

- BIAS SUPPLY**.....Apply -10 volts to the I-F AGC bus at terminal "D" on PW200.
- OSCILLOSCOPE**.....Connect to kinescope cathode lead through diode detector.
- SIGNAL GENERATOR**.....Connect to test point TP3 on PW200.
- VACUUM TUBE VOLTMETER**.....Connect to output of diode detector shown. Set meter for negative voltage readings.
- MISCELLANEOUS**.....Connect test diode detector to pin 7 of V202. See below for adjustment locations.

| STEP | SIGNAL GENERATOR | ADJUST | REMARKS |
|------|--|----------------|--|
| 8 | 4.5 mc. | T202 | Adjust for maximum negative DC on meter. Set generator for 1.0 to 1.5 volts when peaked. T201A top core and T202 core should penetrate the coil from top of can when finally peaked. |
| 9 | 4.5 mc. | T201A (top) | |
| 10 | Disconnect the diode test detector. Turn off signal generator and tune in strongest signal in area, adjusting volume control for normal volume (approx. 1/4 turn from C.C.W.). Turn core of T203 flush with top of coil form. Remove bias. | | |
| 11 | — | T203 | Turn core clockwise to 2nd peak adjusting for maximum volume. |
| 12 | 4.5 mc., 600 cycle, AM mod. | T201B (bottom) | Adjust for minimum 600 cps indication on oscilloscope. The core should penetrate the coil from the board end when finally adjusted. |

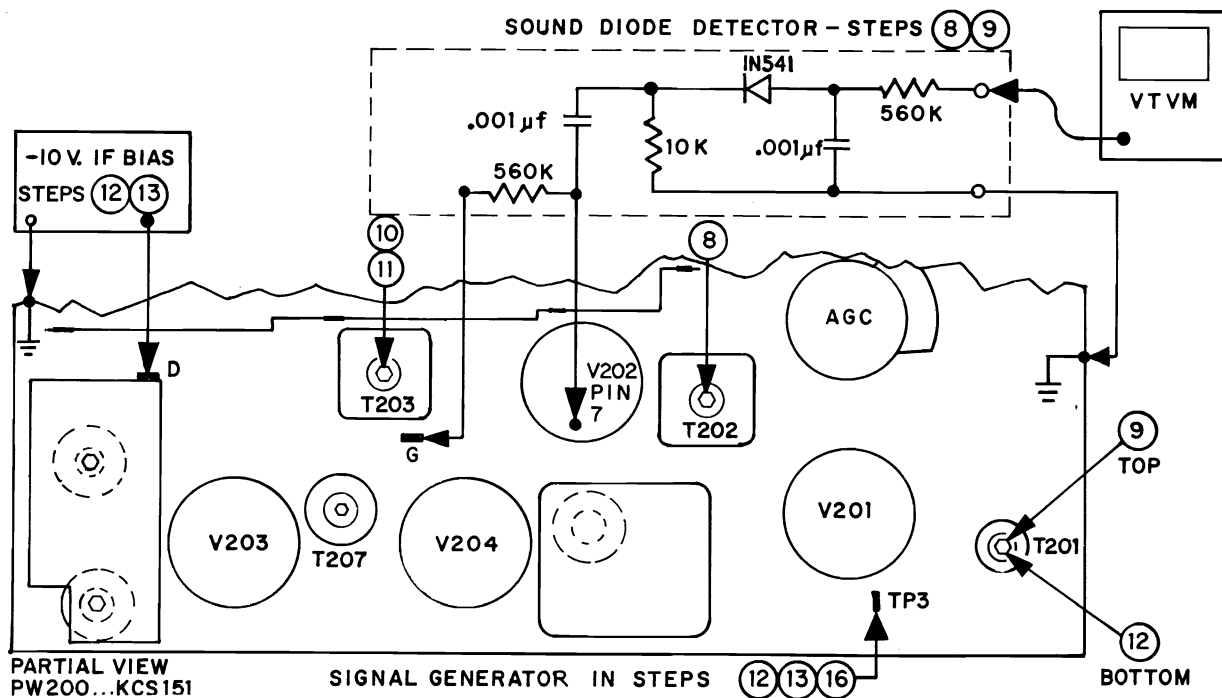

SEARS, ROEBUCK and CO.

SEARS | *Silvertone*
TELEVISION CHASSIS 456.61560 456.61561
 528.61560 528.61561

Used in Models 5120, 5121

(Service material on pages 115 through 119)

WIDTH DEVICE ADJUSTMENT

The Width Device is a piece of metallic foil attached to a sheet of plastic; it forms a half circle around the top half of the picture tube neck.

1. Loosen the screw on clamp which secures the Deflection Yoke to the picture tube.
2. During the following adjustment hold the Deflection Yoke in position and do not disturb the relative position between the Deflection Yoke and the picture tube. Slide the Width Device forward or backward until the picture has proper width. The plastic corners can be bent to ease moving.

HORIZONTAL FREQUENCY AND HORIZONTAL STABILIZER CONTROL ADJUSTMENT

1. Tune set to an active channel.
2. Short out L104 (Horizontal Stabilizer Coil) by connecting a jumper across J57 and J58.
3. Turn variable cathode resistor (R51) completely counter-clockwise.
4. Advance R51 SLOWLY clockwise until picture just locks in.
5. Remove jumper from horizontal stabilizer coil.
6. Lock in picture by adjusting the horizontal stabilizer coil, which in effect is the Horizontal Hold Control.

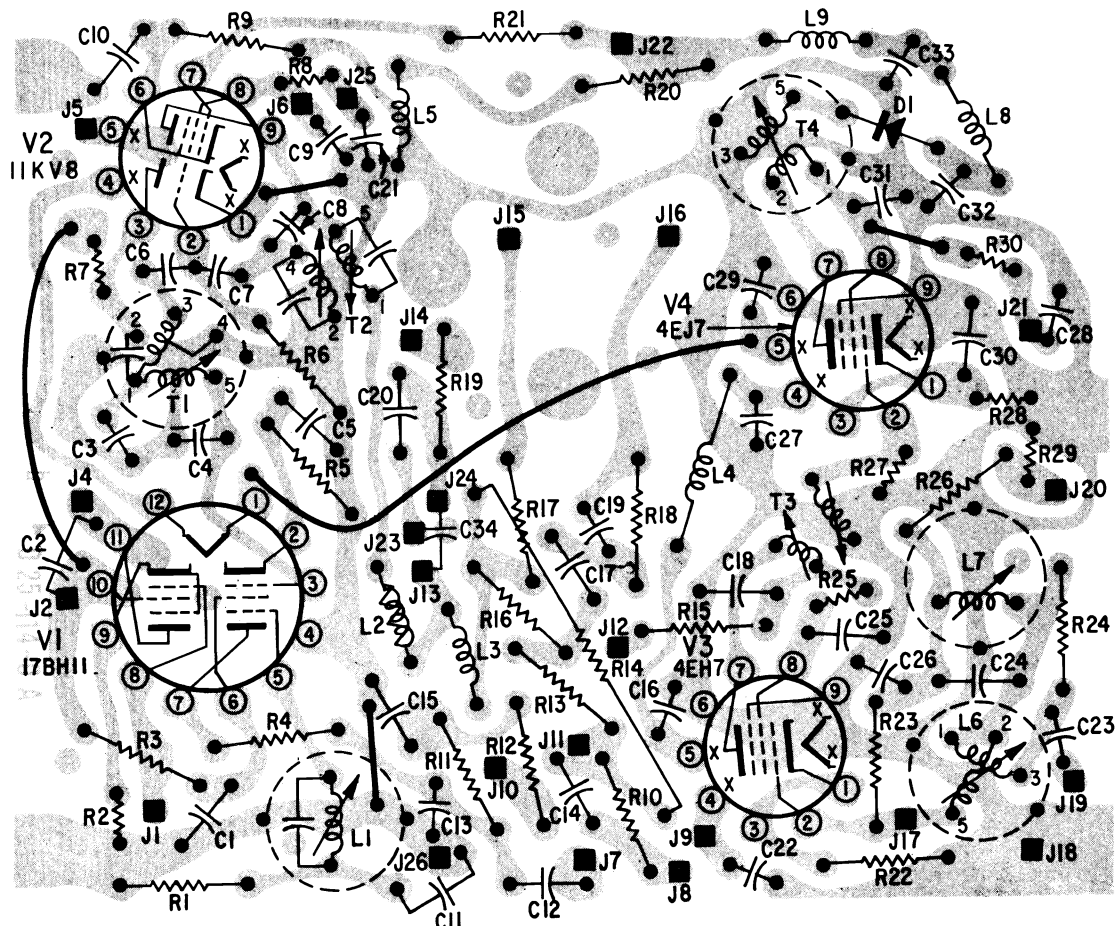

Wiring Diagram I.F. Sync. Sound Board

VOLUME TV-24, ADDITIONAL 1965 TELEVISION SERVICING INFORMATION

SEARS, ROEBUCK Models 5120, 5121, Service Data, Continued

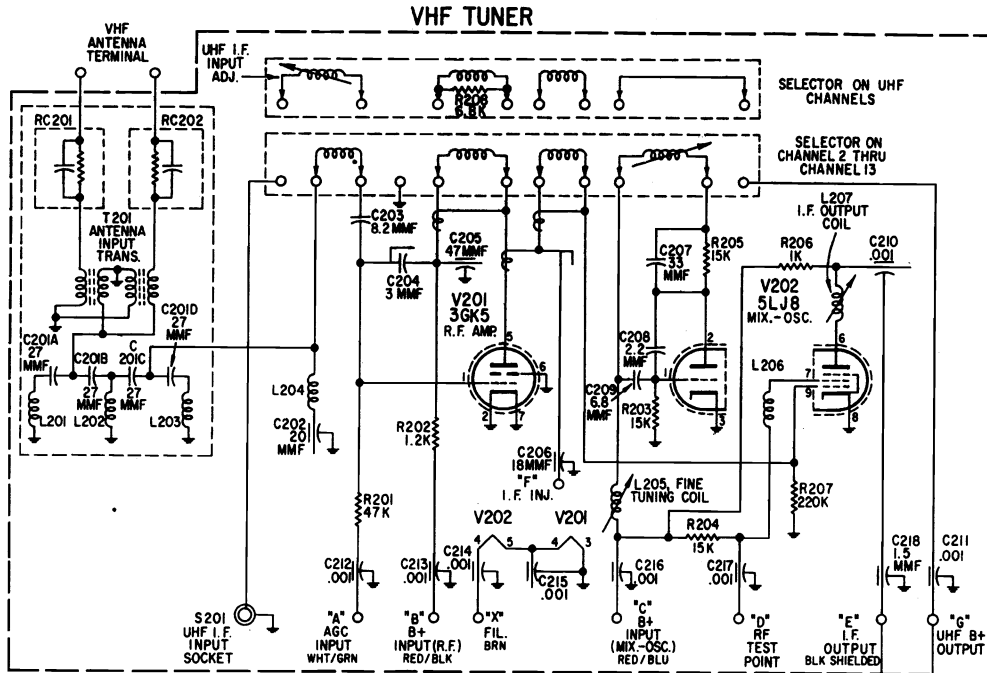

- NOTES:
1. ALL RESISTORS ARE 1/2 WATT, UNLESS OTHERWISE NOTED.
 2. ALL CAPACITORS ARE MFD, UNLESS OTHERWISE NOTED.
 3. TUNER IS SHOWN IN VHF CHANNELS POSITION.
 4. (*) VALUE OF THIS CAPACITOR WILL VARY, REPLACE WITH EXACT VALUE REMOVED.

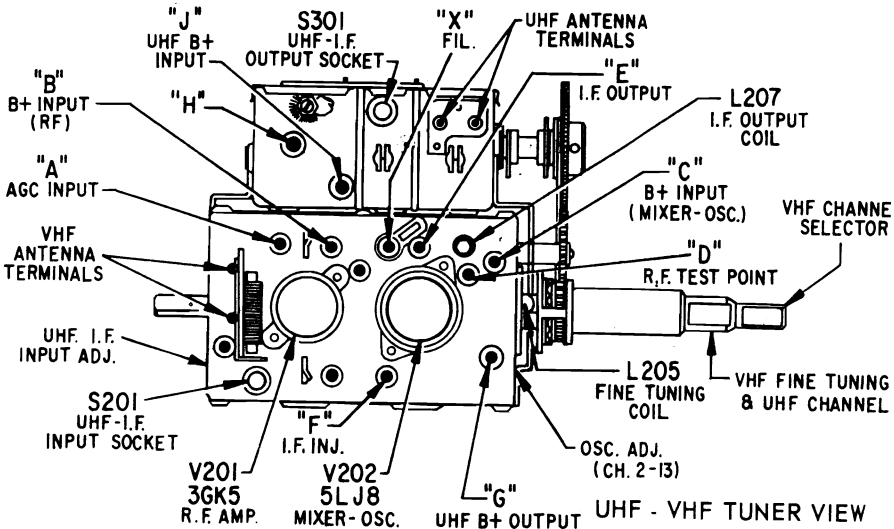

| | | | |
|-------|--|-----------|-------------|
| WF-17 | | 570V P-P | 7875 \sim |
| WF-16 | | 570V P-P | 7875 \sim |
| WF-15 | | 98V P-P | 60 \sim |
| WF-14 | | 2.6V P-P | 60 \sim |
| WF-13 | | 96V P-P | 60 \sim |
| WF-12 | | 1040V P-P | 60 \sim |
| WF-11 | | 200V P-P | 60 \sim |
| WF-10 | | 128V P-P | 60 \sim |
| WF-9 | | 56V P-P | 60 \sim |
| WF-8 | | 18V P-P | 7875 \sim |
| WF-7 | | 8V P-P | 7875 \sim |
| WF-6 | | 150V P-P | 7875 \sim |
| WF-5 | | 150V P-P | 7875 \sim |
| WF-4 | | 50V P-P | 7875 \sim |
| WF-3 | | 2V P-P | 60 \sim |
| WF-2 | | 3V P-P | 60 \sim |
| WF-1 | | 35V P-P | 60 \sim |

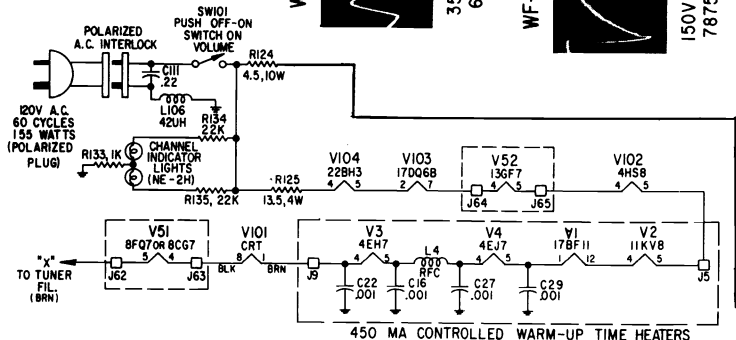
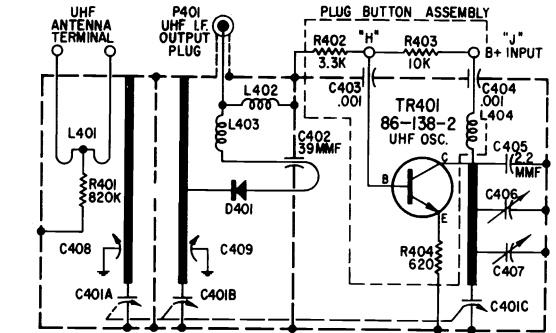

VOLUME TV-24, ADDITIONAL 1965 TELEVISION SERVICING INFORMATION

SEARS, ROEBUCK Models 5120, 5121, Schematic Diagram, Continued

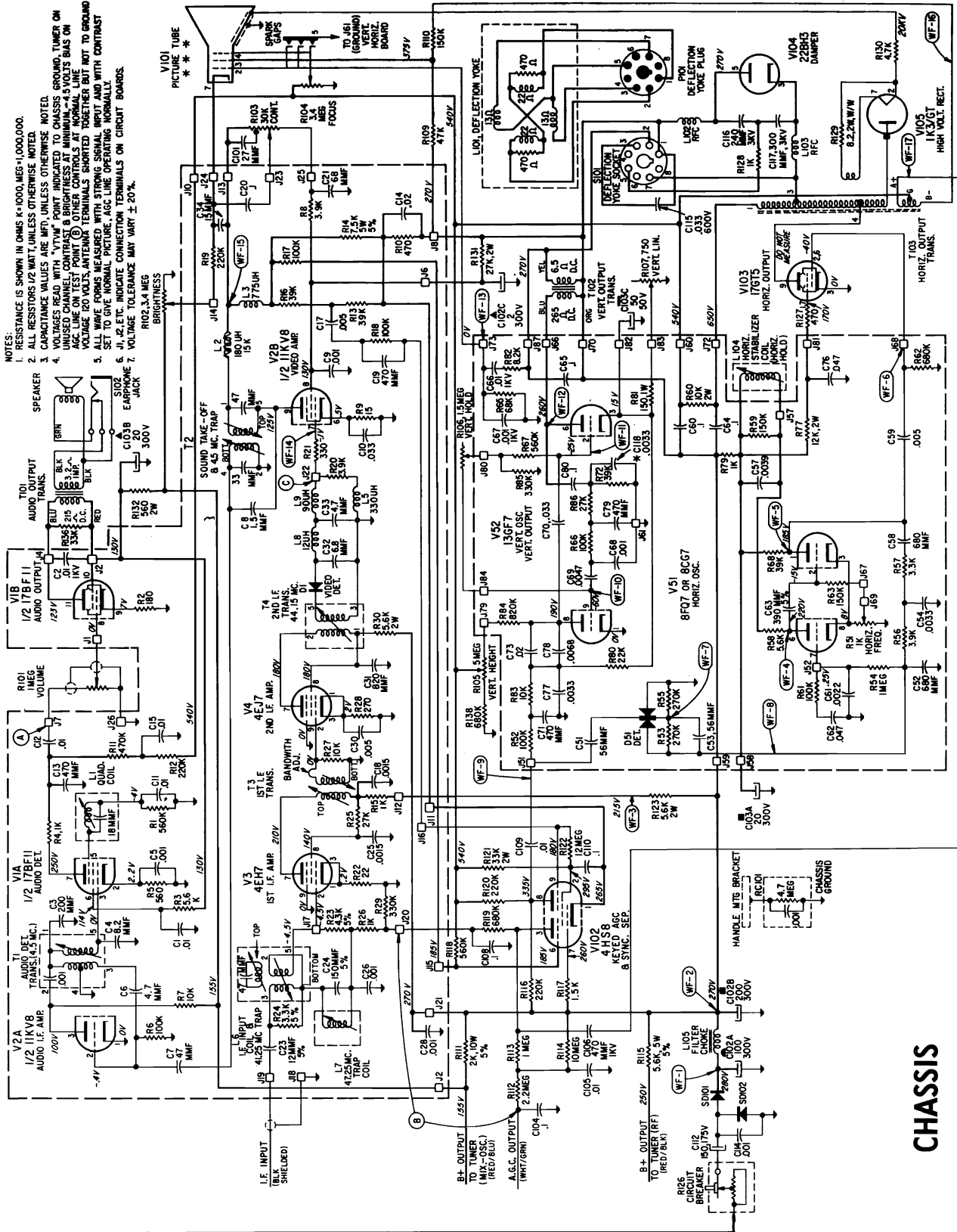

- NOTES:
1. RESISTANCE IS SHOWN IN OHMS K=1000, MEG=1,000,000.
 2. ALL RESISTORS 1/2 WATT, UNLESS OTHERWISE NOTED.
 3. CAPACITANCE VALUES ARE MFD, UNLESS OTHERWISE NOTED.
 4. VOLTAGES READ WITH VTVM POINT INDICATED TO CHASSIS UNLESS OTHERWISE NOTED.
 5. ALL WAVE FORMS MEASURED WITH STRONG SIGNAL INPUT AND WITH CONTRAST SET TO GIVE NORMAL PICTURE. AGC LINE OPERATING NORMALLY.
 6. J1, J2, ETC. INDICATE CONNECTION TERMINALS ON CIRCUIT BOARDS.
 7. VOLTAGE TOLERANCE MAY VARY ± 20%.

CAUTION: Discharging or metering of second anode of picture tube must be to main chassis only.

* Component wired to circuit side of board
 *** 19" Picture Tube - 19DQP4 or 19DWP4

CHASSIS
 456.61560 456.61561
 528.61560 528.61561

VOLUME TV-24, ADDITIONAL 1965 TELEVISION SERVICING INFORMATION

SEARS, ROEBUCK Models 5120, 5121, Alignment Information, Continued

PRELIMINARY

Alignment is an exacting procedure and should be undertaken only when necessary. The following equipment is required for alignment work.

1. Hickok 610, 610A Signal Generator or equivalent where a 4.5 Mc Crstal controlled frequency (CW) is available.
Diode Detector Probe (see Figure 4). The following I.F. Carriers are necessary.

| | |
|---|---|
| 4.5 Mc Inter-carrier Sound IF | 44.15 Mc Video IF Center Frequency |
| 41.25 Mc Video IF Sound Carrier Frequency | 45.75 Mc Video IF Picture Carrier Frequency |
| 42.55 Mc Video IF Bandwidth Marker | 47.25 Mc Marker |
2. Electronic voltmeter (VTVM)
3. RF Sweep generator with a frequency range of 40 to 50 Mc with a sweep width of at least 10 Mc, having an adjustable output of at least 0.1 volts.
4. Cathode ray oscilloscope, preferably with a wide band vertical amplifier and an input calibrating source.

PRELIMINARY ALIGNMENT NOTES

- a. It is recommended that the receiver be connected to an isolation transformer during alignment. Allow at least 5 minutes for set to warm up before any alignment is attempted.
- b. Connect oscilloscope hot lead through 10K ohm isolation resistor to Point (C) Connect ground lead of oscilloscope directly to main chassis.
(Adjust signal input to maintain 2 volts peak to peak)
- c. Apply -6 volts bias to AGC IF line, -side to Point (B) +side to chassis.
- d. Connect correct signal generator as shown in chart below.
- e. Clip hot lead of marker generator to the insulation of RF sweep generator hot lead. Connect ground lead to chassis.

VIDEO I.F. ALIGNMENT

| Step | Sweep Generator (40-50 MC) Connect To | Marker Generator See Note Above | Output Waveform | Adjust | Remarks |
|------|---|---------------------------------|-----------------|---------------------------|--|
| 1. | Pin 2 of 4EH7 (V3) thru .001 mfd. Cap. | 44.15 MC | Figure 1 | T4 | Adjust T4 for maximum response at 44.15 Mc. |
| 2. | Same | Same | Same | T3 (Top) | Turn bottom core of T3 to bottom of coil form before adjusting T3 top. Adjust T3 top for maximum response at 44.15 Mc. |
| 3. | Same | 45.75 MC 42.55 MC | Same | T3 (Bottom) | Adjust T3 (Bottom) for symmetry of response shown in Figure 1. |
| 4. | Same | 45.75 MC | Same | T3 (Top) | Readjust T3 top to position the 45.75 Mc Marker at the 3 db point of the response curve. |
| 5. | If necessary, repeat steps 1 through 4 to obtain proper response. NOTE: If proper 3.2 MC bandwidth is not obtained. (3.2 Mc \pm .2 Mc), refer to Bandwidth Loop Adjustment. | | | | |
| 6. | Point "F" (Converter Test Point) See Fig. 3 | 41.25 MC | Figure 2 | L6 (Top) | Adjust L6 top for minimum response at 41.25 Mc. |
| 7. | Same | 47.25 | Same | L7 | Adjust 47.25 trap for minimum response at 47.25 Mc. |
| 8. | Same | 45.75 MC | Same | L207 Tuner IF Output Coil | Adjust L207 to position the 45.75 Mc marker at the 6 db point of response curve. |
| 9. | Same | 42.55 MC 45.75 MC | Same | L6 (Bottom) | Adjust L6 (bottom) for symmetry of response in Figure 2. |
| 10. | If necessary, repeat steps 6 through 8 to obtain response curve of Figure 2. | | | | |

BANDWIDTH LOOP ADJUSTMENT

The first I.F. transformer has a vertical hairpin loop in the secondary winding. This loop must not be touched unless the bandwidth specifications (3 Mc \pm .2 Mc) are incorrect. Adjust as follows:

1. To narrow the I.F. response curve, pull the loop away from the primary of T3 (top). Repeat steps 2 through 5 of the Video I.F. Alignment. See Figure 5.
2. To broaden the I.F. response curve, press the loop toward the primary of T3 (top). Repeat steps 2 through 5 of the Video I.F. Alignment. See Figure 5.

SOUND ALIGNMENT

PRELIMINARY

Connect -10 volts bias to point (B). This will disable the Video I.F. circuits.

| Step | SIGNAL GENERATOR | | METER CONNECTION VTVM | ADJUST |
|------|---|---------------------|--|---|
| | FREQUENCY | CONNECT TO | | |
| 1. | 4.5 Mc Xtal Controlled | Pin 7 of 8JV8 (V2B) | Pin 3 of V1A thru a diode detector probe. See Fig. 4 | T1 (single core) T2 (top & bottom) for maximum output on VTVM. |
| 2. | Same - Output should be greater than 10 Kuv | Same | Point "D" | L1 (single core) for maximum. NOTE: Two peaks may be observed, tune to the highest peak. This is a sharp peak and must be adjusted carefully. |
| 3. | Remove all equipment. | | | |
| 4. | Set fine tuning for a normal picture and if necessary touch up quadrature coil (L1) for best sound. | | | |
| 5. | Touch up the 4.5 Mc trap (top of T2) for minimum sound beat in picture. | | | |

VOLUME TV-24, ADDITIONAL 1965 TELEVISION SERVICING INFORMATION

SEARS, ROEBUCK Models 5120, 5121, Service Information, Continued

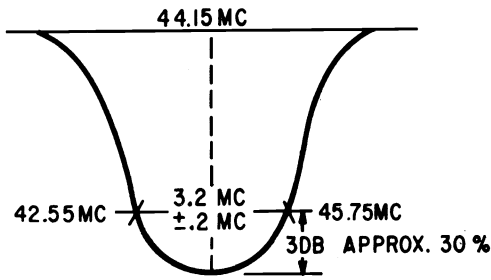

FIGURE 1

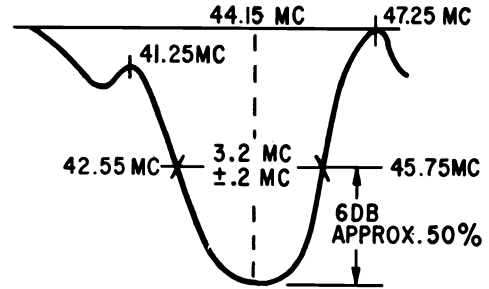

FIGURE 2

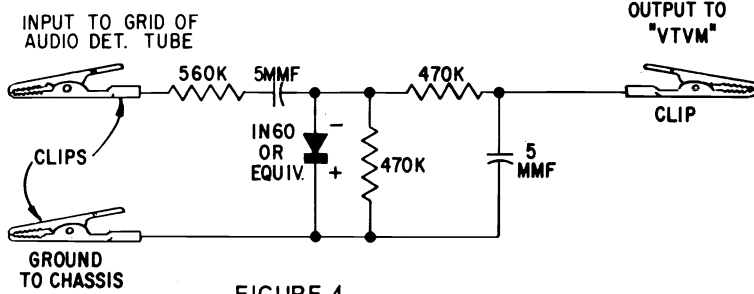

FIGURE 4

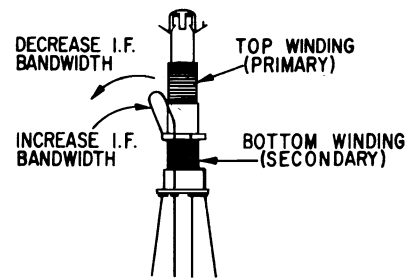
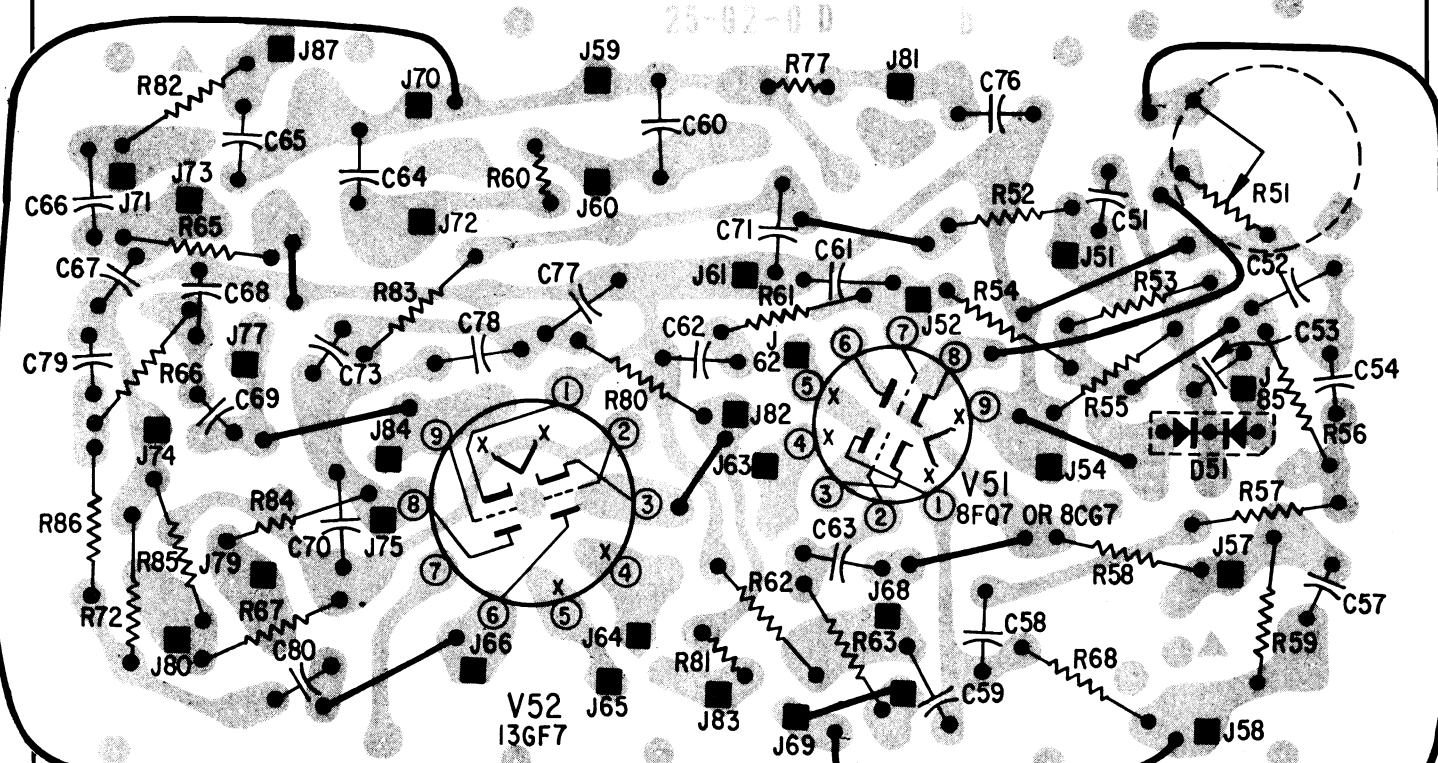

FIGURE 5



1. WIRING DIAGRAM IS SHOWN FROM CIRCUIT SIDE OF BOARD.
2. SOLID LINES INDICATE WIRE JUMPERS.
3. WIRE JUMPER UNDER V51 TUBE SOCKET BETWEEN PIN NO.3 & PIN NO. 8, NOT SHOWN.

Horizontal - Vertical Oscillator Board

SEARS, ROEBUCK and CO.

SEARS | *Silvertone*

Chassis 456.61450, 456.61451, 456.61452, 456.61453, 456.61454, 456.61455, 456.61460, 456.61461, 456.61466, 456.61467, 456.61474, 456.61475, 456.61510, 456.61511, 456.61512, 456.61513, 528.61340, 528.61341, 528.61450, 528.61451, 528.61452, 528.61453, 528.61454, 528.61455, 528.61460, 528.61461, 528.61466, 528.61467, 528.61474, 528.61475, 528.61480, 528.61481, 528.61484, 528.61485, 528.61510, 528.61511, 528.61512, 528.61513, 529.61450, 529.61451, 529.61452, 529.61453, 529.61454, 529.61455, 529.61460, 529.61461, 529.61466, 529.61467, 529.61474, 529.61475, 529.61510, 529.61511, 529.61512, 529.61513, used in Models 5150, 5151, 5152, 5153, 5154, 5155, 5156, 5157, 5158, 5163, 5164, and 5165. (Chassis 529.61340 and 529.61341 are also similar.)

DEFLECTION YOKE, CENTERING RING AND BEAM ALIGNER ADJUSTMENT

Follow this procedure in adjusting the Deflection Yoke, Centering Rings and Beam Aligner (if required):

1. Turn the receiver on and disconnect the antenna.
2. The deflection yoke is held on the neck of the picture tube by a clamp device. Loosen the clamp, by unscrewing the screw on the clamp, and carefully move the yoke as far forward as possible on the neck of the picture tube. Rotate the yoke until the top and bottom edges of the raster are squared with the chassis. Tighten the screw.

NOTE: A Width Device is located between the Deflection Yoke and the neck of the picture tube. This must be adjusted before the Yoke clamp is tightened.

3. Center the raster horizontally and vertically, and eliminate shaded corners by simultaneously, but independently, rotating the centering rings until the best effect is obtained.
4. Turn the brightness control to the point giving normal picture brilliance. Maintain brightness at this level during the following adjustments. Center the contrast control.
5. Position the Beam Aligner on the base of the picture tube. For correct orientation, one side of the Beam Aligner is marked with a Part Number. This side of the magnet should be on top, with the magnet on the anode lead side of the tube. Move the Beam Aligner forward and backward and rotate on the neck of the picture tube to the point which produces the best focus.

NOTE: Some Picture Tubes may not have a Beam Aligner, in which case step 5 should be ignored. Since there is some interaction between the Beam Aligner and the Centering Rings, the two may require readjustment to obtain the best performance.

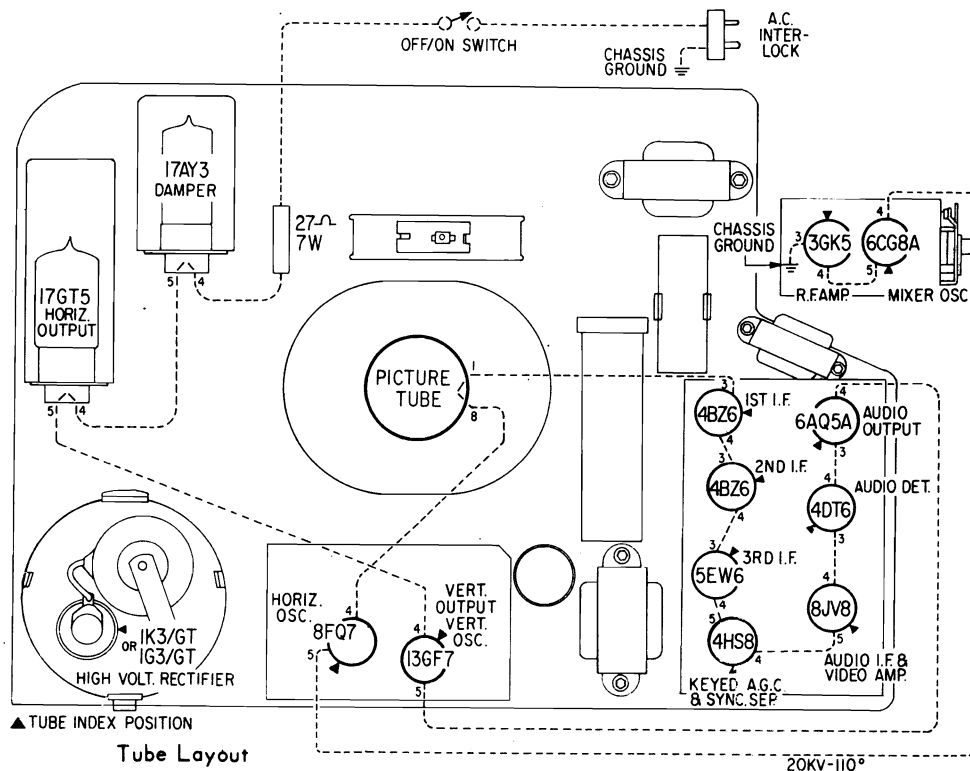

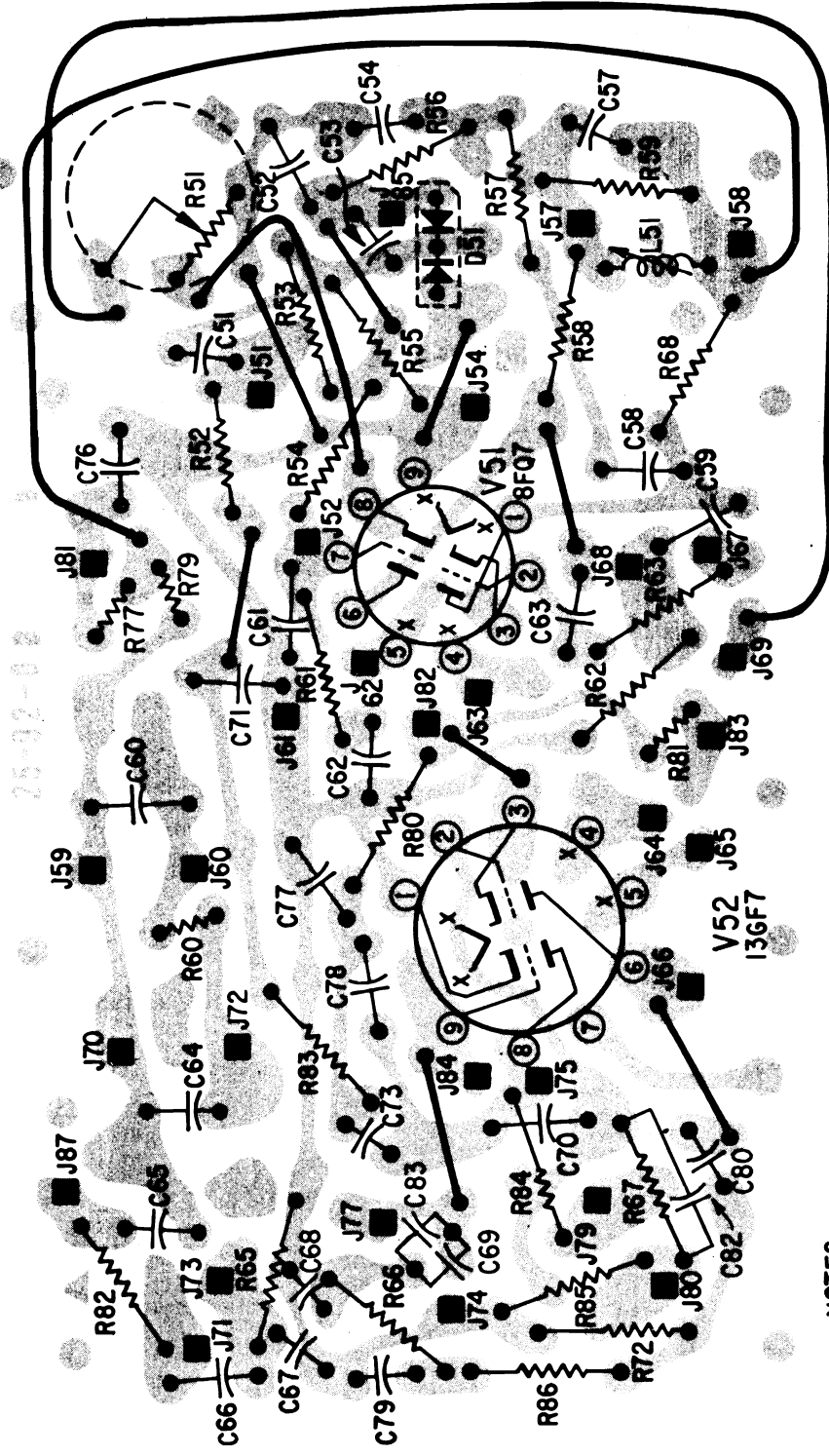

- NOTES:
1. WIRING DIAGRAM IS SHOWN FROM CIRCUIT SIDE OF BOARD.
 2. SOLID LINES INDICATE WIRE JUMPERS.
 3. WIRE JUMPER UNDER V51 TUBE SOCKET BETWEEN PIN NO.3 & PIN NO.8, NOT SHOWN.

Horizontal-Vertical Oscillator Board

VOLUME TV-24, ADDITIONAL 1965 TELEVISION SERVICING INFORMATION

SEARS, ROEBUCK Models 5150/58 etc., Service Data, Continued

VHF TUNER

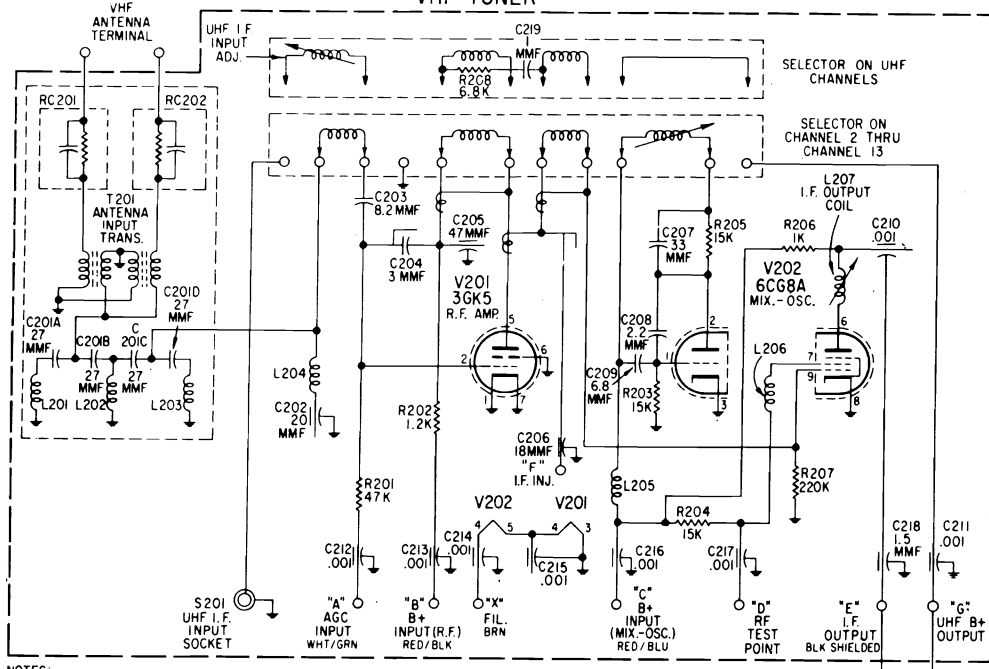

- NOTES:
1. ALL RESISTORS ARE 1/2 WATT, UNLESS OTHERWISE NOTED.
 2. ALL CAPACITORS ARE MFD, UNLESS OTHERWISE NOTED.
 3. TUNER IS SHOWN IN VHF CHANNELS POSITION.
 4. (*) VALUE OF THIS CAPACITOR WILL VARY, REPLACE WITH EXACT VALUE REMOVED.

| | | |
|-------|--|--------------------|
| WF-17 | | 650V P-P 7875 ~ |
| WF-16 | | 675V P-P 7875 ~ |
| WF-15 | | 105V P-P 60 ~ |
| WF-14 | | 3.5V P-P 60 ~ |
| WF-13 | | 95V P-P 60 ~ |
| WF-12 | | 900V P-P 60 ~ |
| WF-11 | | 170V P-P 60 ~ |
| WF-10 | | 135V P-P 60 ~ |
| WF-9 | | 60V P-P 60 ~ |
| WF-8 | | 17VP-P 7875 ~ |
| WF-7 | | 11VP-P 7875 ~ |
| WF-6 | | 150V P-P 7875 ~ |
| WF-5 | | 150V P-P 7875 ~ |
| WF-4 | | 60V P-P 7875 ~ |
| WF-3 | | 2VP-P 60 ~ |
| WF-2 | | 2.4V P-P 60 ~ |
| WF-1 | | 35V P-P 60 ~ |

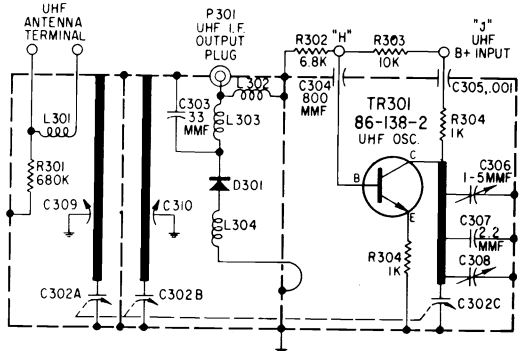

UHF TUNER (95-374-0)

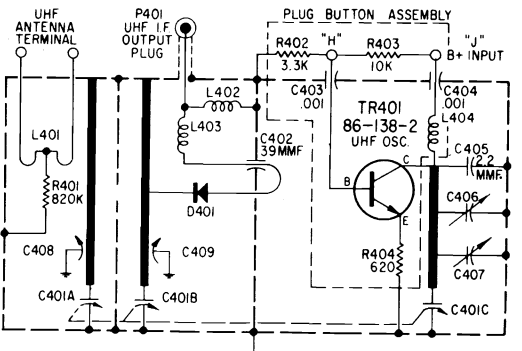

UHF TUNER (95-381-0)

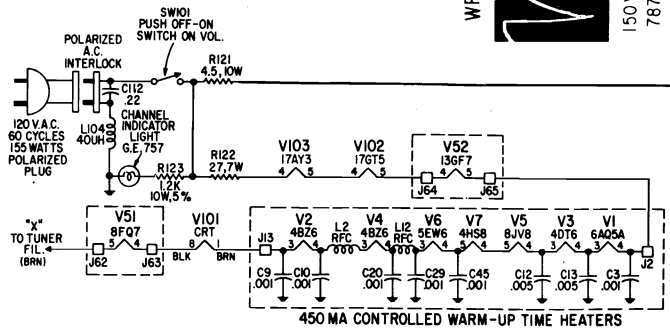

SEARS, ROEBUCK Models 5150/58 etc., Schematic Diagram, Continued

1. RESISTANCE IS SHOWN IN OHMS K=1000, MEG=1,000,000.
2. ALL RESISTORS 1/2 WATT, UNLESS OTHERWISE NOTED.
3. CAPACITANCE VALUES ARE MFD, UNLESS OTHERWISE NOTED.
4. VOLTAGES UNLESS OTHERWISE NOTED, "VTVM" POINT INDICATED TO CHASSIS GROUND, TUNER ON UNUSED CHANNELS, CONTRAST & BRIGHTNESS ADJUSTERS, ANTENNA TERMINALS SHORTED TOGETHER BUT NOT TO GROUND.
5. ALL WAVE FORMS MEASURED WITH STRONG SIGNAL INPUT AND WITH CONTRAST SET TO GIVE NORMAL PICTURE, AGC LINE OPERATING NORMALLY.
6. J1, J2, ETC. INDICATE CONNECTION TERMINALS ON PRINTED BOARDS.
7. VOLTAGE TOLERANCE MAY VARY ± 20%.

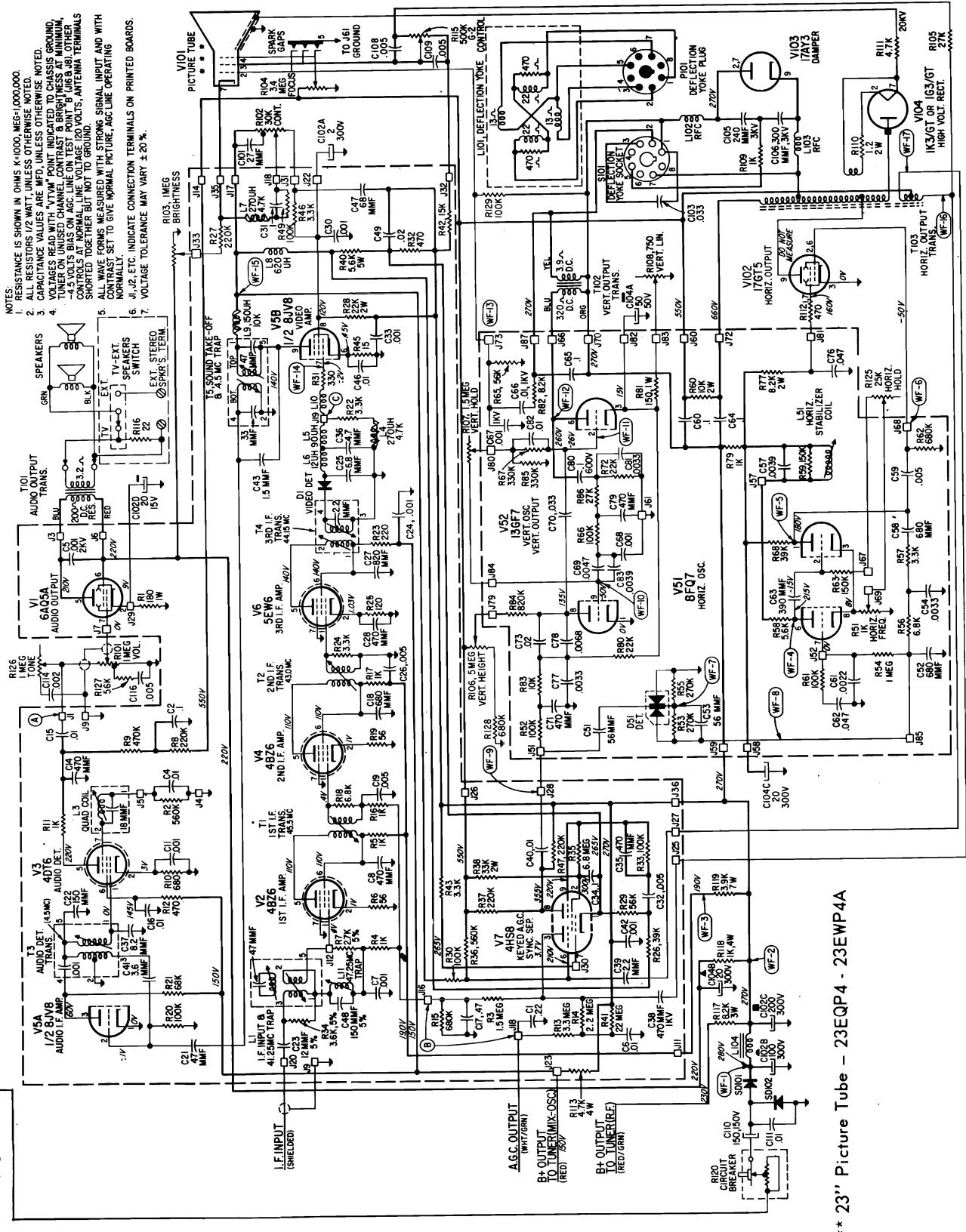

*** 23" Picture Tube - 23EQP4 - 23WP4A

VOLUME TV-24, ADDITIONAL 1965 TELEVISION SERVICING INFORMATION

SEARS, ROEBUCK Models 5150/58 etc., Alignment Information

TELEVISION ALIGNMENT PROCEDURE

The bottom slug on all two slug coils is the one that is closest to the chassis mounting lugs of the coil.

PRELIMINARY

Alignment is an exacting procedure and should be undertaken only when necessary. The following equipment is required for alignment work:

1. Signal Generator, with an output of at least .1 volt.
2. Electronic voltmeter (VTVM).
3. RF sweep generator with a frequency range of 40 to 50 Mc with a sweep width of at least 10 Mc having an adjustable output of at least 0.1 volts.
4. Cathode ray oscilloscope, preferably with a wide band vertical amplifier and an input calibrating source.
5. Isolation transformer.
 - a. It is recommended that the receiver be connected to an isolation transformer during alignment. Allow at least 5 minutes for set to warm up before any alignment is attempted.
 - b. Apply -3 volts bias to AGC line negative side to junction of J18 and J16 Point (B) positive side to chassis.
 - c. For sweep alignment, the peak output shall not exceed 3 volts.

VIDEO I.F. ALIGNMENT

1. Connect Sweep Generator to Pin 1 of V6.
2. Connect Marker Generator ground lead to chassis, hot lead to insulator of Sweep Generator. Feed in a 44.15 Mc marker.
3. Connect oscilloscope hot lead through 10K ohm isolation resistor to Point (C), J19. Connect ground lead of scope directly to main chassis. Connect VTVM to J19 and ground.
4. Adjust both cores of T4 to obtain wave form shown in Figure 3.
5. Connect Signal Generator hot lead to the grid of the 1st I.F. Amplifier (J12) ground lead to chassis.
6. Feed in a 43.0 Mc marker. Adjust T2 for peak reading on VTVM. Adjust Signal Generator to give reading of approximately 2.0 volts on VTVM.
7. Feed in a 45.5 Mc marker. Adjust T1 for peak reading on VTVM. Adjust Signal Generator to give reading of approximately 2.0 volts on VTVM.
8. Connect Sweep Generator to the grid of the 1st I.F. Amplifier. Connect Signal Generator ground lead to chassis, hot lead to insulator of Sweep Generator.
9. The wave form shown in Figure 4 should be evident.
10. To obtain a flat curve it may be necessary to slightly touch up the secondary of the 3rd I.F. (T4).

ALIGNMENT OF CONVERTER, I.F. INPUT & TRAPS

1. Feed a 40 - 50 Mc sweep into the I.F. Alignment Point. (See Figure 1)

The converter coil (L207) and the I.F. input coil (L1) should be adjusted first. Adjust for wave form and 44.15 Mc marker shown in Figure 5. Then adjust L11 for 47.25 Mc and the trap of L1 top for 41.25 Mc. This procedure should be followed because the I.F. input coil has a marked effect on the tuning of the 47.25 Mc trap, but the trap has little effect on the I.F. input coil. The wave shape should be as shown in Figure 5.

SOUND ALIGNMENT

PRELIMINARY TO ALIGNMENT:

Connect 4.5 Mc generator to grid of video amplifier. Connect ground side of generator lead to chassis. Set generator to "Sweep Off" position. Insert 4.5 Mc crystal in holder. Modulation switch to "CW" position. Output control of generator at maximum.

Connect 4.5 volts bias (negative side) to AGC test point. Connect positive side of bias to chassis. Tune receiver to an unused channel. Connect the input of the detector probe to the grid of V3, Pin 1 (4DT6). Connect ground point of detector probe to chassis. Connect VTVM to output of detector probe; ground side of VTVM to chassis. NOTE: Meter reading should be no greater than 1.0 volts D.C. Attenuate generator if necessary to adjust meter reading to 1.0 volts D.C.

Tune audio detector transformer (T3) for maximum. Adjust generator to keep meter reading at 1.0 volts D.C. Tune top and bottom of sound take-off and rejection trap (T5) for maximum meter reading. Adjust generator output if necessary. Disconnect detector probe, disconnect VTVM. Attach VTVM only to junction point (J5) of the quad coil (L3) and the 560K resistor (R2), VTVM ground lead to chassis.

Tune quad coil (L3) for maximum. Care should be taken in making this adjustment. The resonant peak of the quad coil circuit is very sharp and requires precise adjustment.

Remove meter, bias voltage, generator; tune set to station; set fine tune for best picture and touch up quad coil (if necessary) for best sound. Also touch up the 4.5 Mc rejection trap (T5 Top) for minimum sound beat in picture.

If it becomes necessary to realign or touch up the quadrature sound circuit in the field use the following procedure:

1. Fine tune set for best picture.
2. Attach VTVM to junction point of quad coil and R2. Set VTVM on 0 to 3v. or 0 to 5v. range D.C.
3. If meter reading is more than 2.0 volts, detune quad coil and rear of 4.5 Mc, I.F. coil.
4. With volume up, adjust sound take-off (T5 Bottom) for best sound. Meter reading need not be observed.
5. Adjust quad coil for maximum voltage and best sound.
6. Adjust 4.5 Mc, I.F. coil (T3) for maximum voltage.
7. Adjust sound trap (T5 Top) for minimum beat in picture.

HORIZONTAL FREQUENCY AND HORIZONTAL STABILIZER CONTROL ADJUSTMENT (Field)

1. Tune set to an active channel. Set horizontal hold control (R125) in the center of its range.
2. Short out L51 (Horizontal Stabilizer Coil) by connecting a jumper across J57 and J58.
3. Turn R51 (Horizontal Frequency Control) completely counterclockwise.
4. Advance R51 SLOWLY clockwise until picture just locks in.
5. Remove jumper from J57 and J58.
6. Leave the horizontal hold control in the center of its range and adjust the horizontal stabilizer coil to lock picture.

NOTE: Turn the horizontal hold control completely counterclockwise and momentarily switch off and on channel, observing to see if the horizontal remains locked or just breaks out of sync. Repeat with horizontal hold control completely clockwise. If the locking range does not appear to be centered, repeat step 6.

VOLUME TV-24, ADDITIONAL 1965 TELEVISION SERVICING INFORMATION

SEARS, ROEBUCK Models 5150/58 etc., Alignment, Continued

FOCUS ADJUSTMENT

Adjust the Focus Control, R104, for the clearest picture.

G-2 CONTROL ADJUSTMENT

1. Advance the brightness and contrast controls completely clockwise.
2. Adjust the G2 control (R115) for sufficient brightness without abnormal blooming or shrinking.

NOTE: Be sure brightness control has sufficient range. If it does not, advance the G2 control slightly clockwise.

WIDTH DEVICE ADJUSTMENT

The Width Device is a piece of metallic foil attached to a sheet of plastic; it forms a half circle around the top half of the picture tube neck. (During all adjustments, the Width Device must remain centered on the top half of the picture tube neck.) Be sure that the Width Device is pulled as far toward the base of the picture tube as possible. The Width Device should be left in this position unless further adjustment is necessary. For further adjustment follow steps given below:

1. Loosen the screw on clamp which secures the Deflection Yoke to the picture tube.
2. During the following adjustment hold the Deflection Yoke in position and do not disturb the relative position between the Deflection Yoke and the picture tube. Slide the Width Device forward or backward until the picture has proper width. The plastic corners can be bent to ease moving.

NOTE: The Width Device may affect the vertical sweep, in which case, the Vertical Height and Vertical Linearity controls may have to be readjusted when the width adjustment has been completed.

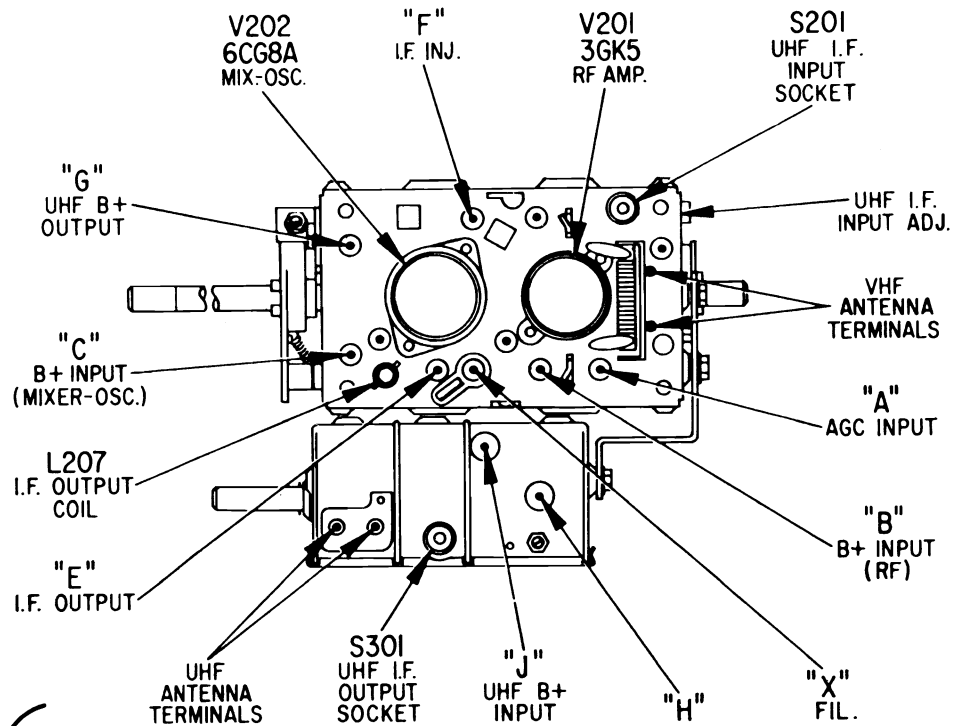

Fig. 1. Pictorial 95-376-0 VHF Tuner with Memory Fine Tuning

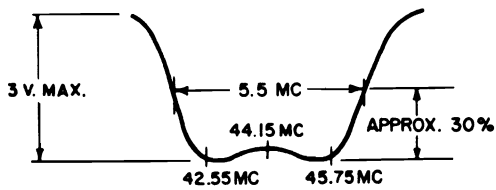

Fig. 3. Response Curve from 3rd I.F. Amplifier

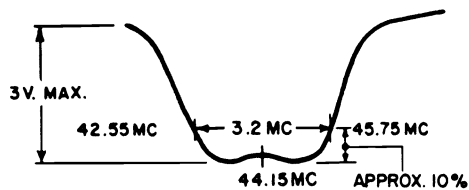

Fig. 4. Response Curve from 2nd I.F. Amplifier

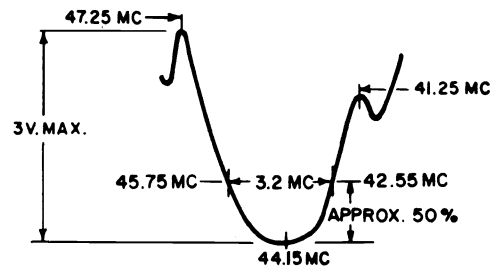
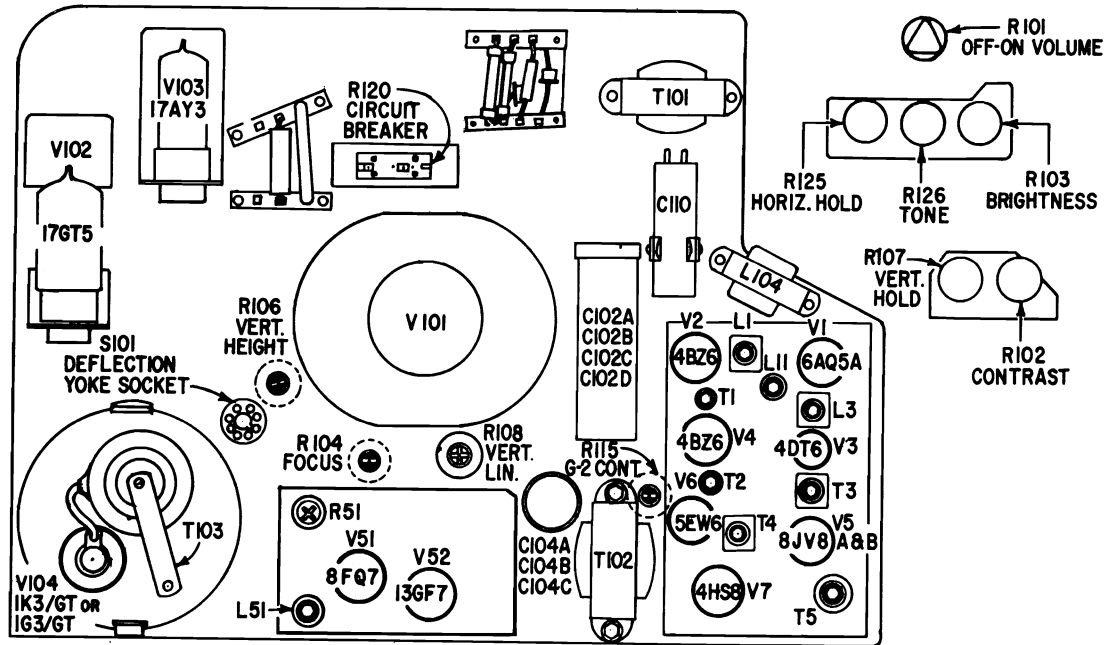

Fig. 5. Response Curve for Converter, I.F. Input & Traps

VOLUME TV-24, ADDITIONAL 1965 TELEVISION SERVICING INFORMATION

SEARS, ROEBUCK Models 5150/58 etc., Service Information, Continued



Tube View of Chassis

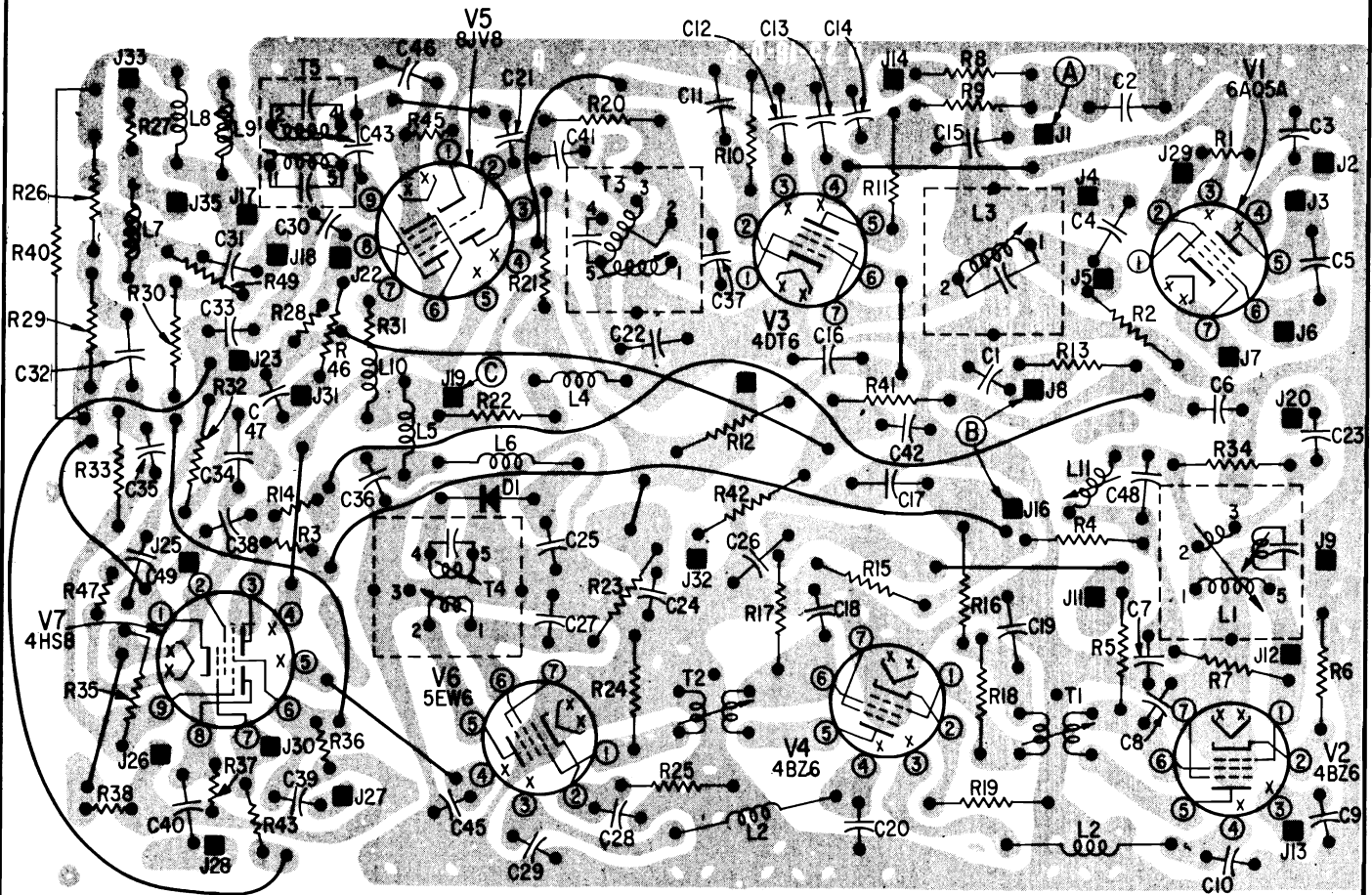

WIRING DIAGRAM SHOWN FROM CIRCUIT SIDE.
SOLID LINES INDICATE WIRE JUMPERS.

Wiring Diagram I.F. Sync. Sound Board

SONY TV4-203 UW

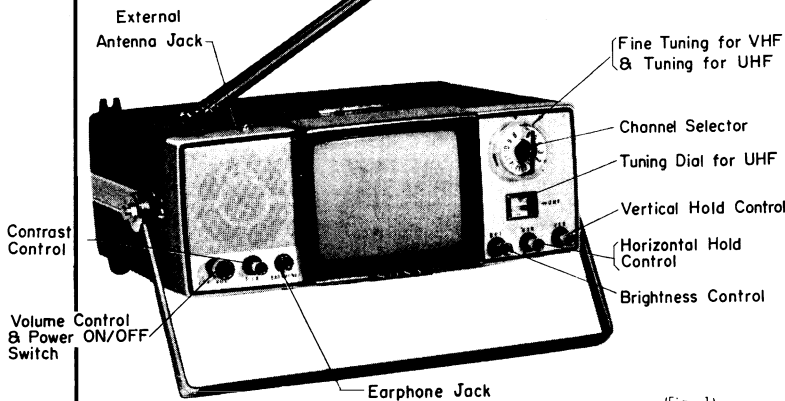

(Fig. 1)

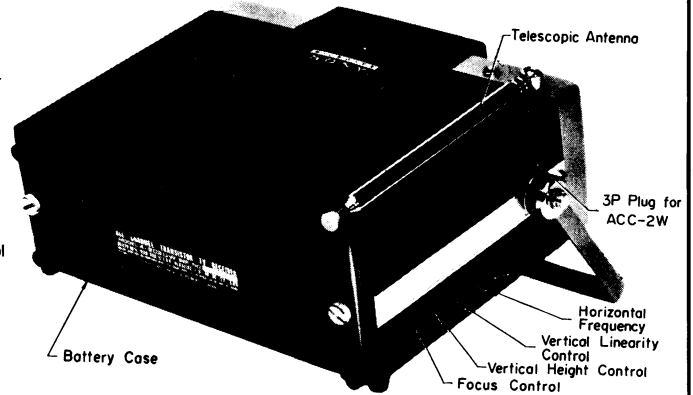

(Fig. 2)

METHOD OF DISASSEMBLING THE SET

To Remove Cabinet Back (See Fig. 14)

1. Untie two screws for battery case and remove battery case.
 2. Remove two rubber foot screws and self tapping screw (⊕P 2.6×6) located on the rear of cabinet.
 3. Remove one philips head screws on the top of the cabinet.
 4. Remove two self tapping screws located on both side of the cabinet.
 5. Grasp cabinet front and cabinet back and remove cabinet back by pulling.
- Note:** Carrying handle must be held when cabinet is removed.

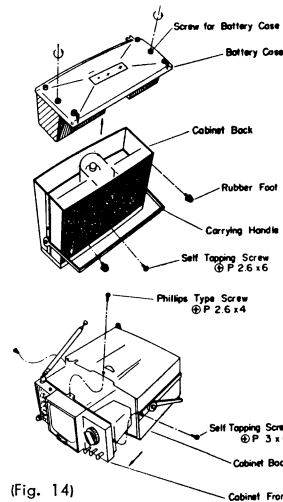

(Fig. 14)

To Remove Power Regulator & Sound Signal Circuit Board (See Fig. 15)

1. Remove one philips head screw (⊕P 3×5) at tuner side.
2. Remove two plastic clear screws (⊕P 3×5) located on the back of the chassis.
3. Pull PC Board to make free from receiver.
4. Disconnect 7P Plug by pulling and lift PC Board off receiver.

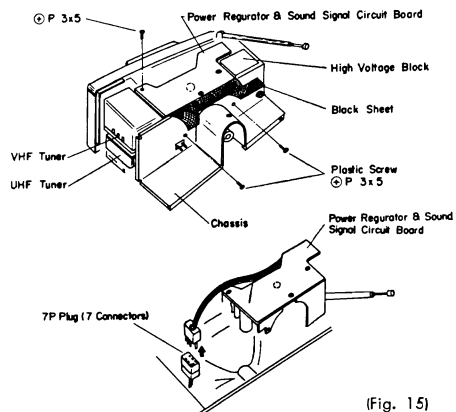

(Fig. 15)

To Remove Video Signal Circuit Board (See Fig. 16)

1. Place receiver up side down.
2. Remove two philips head screws 2 and 3 in the Fig. 16.
3. Lift the Video Signal Circuit Board and pull straight up.
4. Disconnect yellow wire and black co-axial cable (VIF in) by pulling.
5. Disconnect 7-P plug.

To Remove Deflection Circuit Board (See Fig. 16)

1. Remove one screw (① in Fig. 16) located on cabinet front.
2. Lift the Deflection Circuit Board and pull it off from Multi-jack.
3. Disconnect yellow and brown wires from Picture Tube Socket, red, blue, orange and white leads from High Voltage Block, and green and gray from Deflection Yoke. Above wires are removed by pulling at the terminal tip on Deflection Circuit Board.

VOLUME TV-24, ADDITIONAL 1965 TELEVISION SERVICING INFORMATION

SONY Model TV4-203UW Service Information, Continued

To Remove Deflection Yoke (See Fig. 17)

1. Remove cabinet back and video signal circuit board.
2. Disconnect picture tube socket.
3. Loosen the yoke clamp screw.
4. Remove deflection yoke carefully as the picture tube neck is very weak.

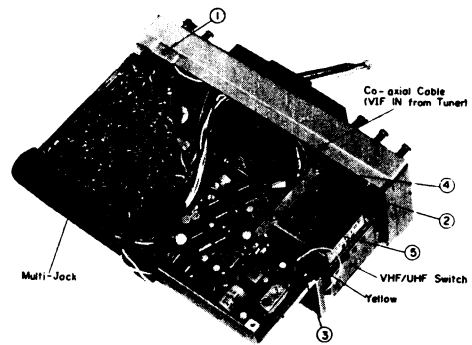

(Fig. 16)

To Remove Chassis Block (See Fig. 18)

1. Remove all the control knobs located on front panel by pulling.
2. Remove cabinet, video signal and deflection circuit boards.
3. Remove CRT anode plug from picture tube.
4. Remove deflection yoke.
5. Remove four screws (+K 2.6 X 4) located at the top bottom and left hand side of the cabinet.
6. Loosen lead wires between cabinet front and picture tube by pulling.
7. Remove external antenna jack from cabinet front by unscrewing jack nut.
8. Unsolder white earphone jack lead at jack terminal.

When channel selector knob is removed, pull channel selector knob and fine tuning knob together to protect any damage of channel selector.

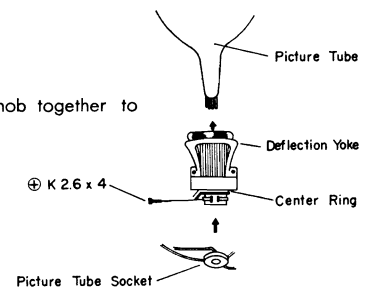

(Fig. 17)

To Remove Telescopic Antenna

1. Remove chassis and cabinet front. (See chassis and front cabinet disassembly)
2. Remove one philips head screw (+P 3 X 5) and spring washer.
3. Unsolder co-axial cable and resistor. (carbon fixed 27K Ω)

To Remove High Voltage Block (See Fig. 19)

1. Remove cabinet back.
2. Remove power regulator and sound signal circuit board and deflection circuit board. (See power regulator and deflection circuit boards disassembly)
3. Unsolder red and blue leads at the terminal on deflection circuit board.
4. Disconnect orange and white leads by pulling them up.
5. Remove anode plug from picture tube.
6. Remove two screws (+P 3 X 5) located on the rear of high voltage block.

To Remove Tuner (See Fig. 19)

1. Remove chassis and cabinet front. (See chassis and front cabinet disassembly)
2. Disconnect shielded wire at the external antenna jack by unsoldering.
3. Remove two philips head screws 4 and 5 in Fig. 16 and lift the tuner block up temporarily then remove it by pulling to the right hand side of the receiver.
4. Loosen two philips head screws located on volume control plate and remove volume control plate from tuner block.

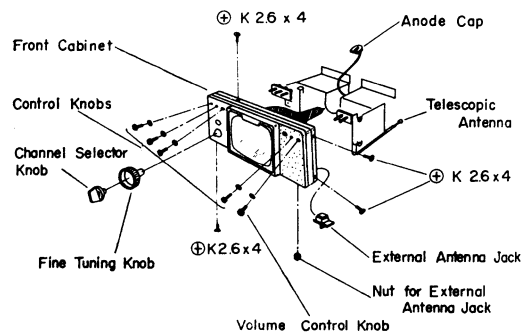

(Fig. 18)

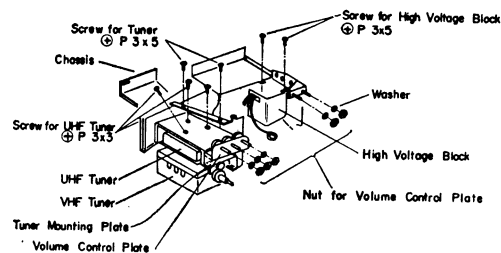

(Fig. 19)

SONY Model TV4-203UW Service Information, Continued

Video IF and Trap Alignment

1. Pre-Alignment Steps

1. Connect Sweep Generator to Tuner TP through 3pF Capacitor.
2. Set Sweep to approx. 25 Mc.
3. Couple Marker Generator to Video IF input.
4. Apply DC Voltmeter across 1000Ω in CR301 and get 0.5 V in DC Voltmeter by adjusting the Attenuator of Sweep Generator.
5. Connect the Oscilloscope to the Video Detector Output.

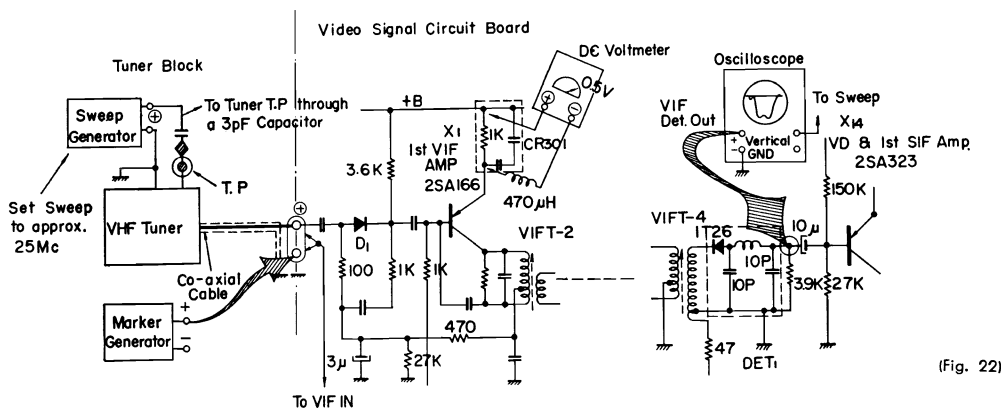

(Fig. 22)

2. Trap Alignment

1. Set Marker Generator to 22.25 Mc.
2. Tune Trap-1 (22.25 Mc) and get minimum dip.
3. Set Marker Generator to 28.25 Mc.
4. Tune Trap-2 (28.25 Mc) and get minimum dip.

3. Video IF Alignment

1. Set Marker Generator to 23.45 Mc for VIFT2 adjustment, then 26.75 Mc for VIFT3 adjustment.
2. Get Standard Response Curve as shown in Fig. 23 by adjusting VIFT2 and VIFT3.

| Adjusting Point | Center Frequency | Band Width | Damping Resistors |
|-------------------------|------------------|------------|-------------------|
| VIFT 1 (built in Tuner) | 24.3 Mc | 3 Mc | |
| 2 | 23.6 Mc | 1 Mc | R305 |
| 3 | 26.3 Mc | 1 Mc | R313 |
| 4 | 25.5 Mc | 3 Mc | |
| 5 | 26.75 Mc | 3.8 Mc | |

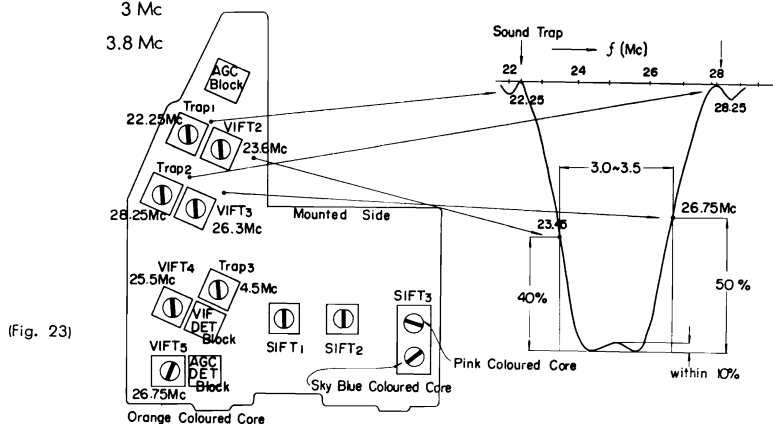

(Fig. 23)

Distribution of VIFT, SIFT & Detector Block

Standard Response Curve

VOLUME TV-24, ADDITIONAL 1965 TELEVISION SERVICING INFORMATION

SONY Model TV4-203UW Schematic Diagram

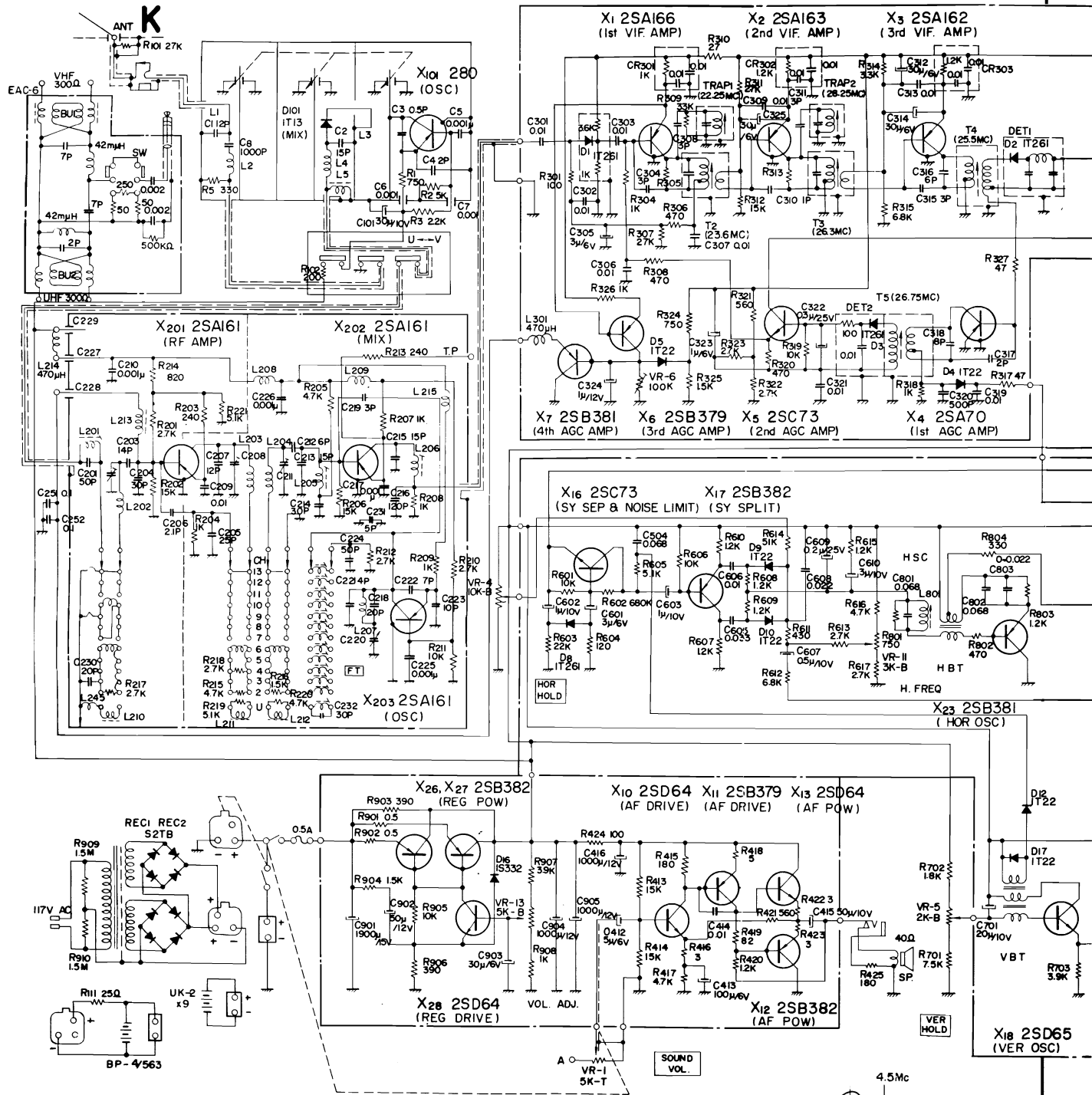

4. Sound IF Alignment

Connections (Refer to Fig. 25)

- Step 1. Set SSG to 4.5 Mc (AM 1,000%/s, 30% Modulation) and get the minimum voltage of meter by adjusting Trap-3.
- Step 2. Adjust SIFT1, 2 and 3 so as to get the S shaped wave shown in Fig. 24.

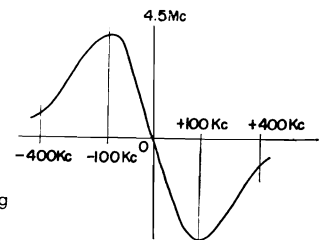

(Fig. 24

Standard Response for Sound Detector

VOLUME TV-24, ADDITIONAL 1965 TELEVISION SERVICING INFORMATION

SONY Model TV4-203UW Schematic Diagram, Continued

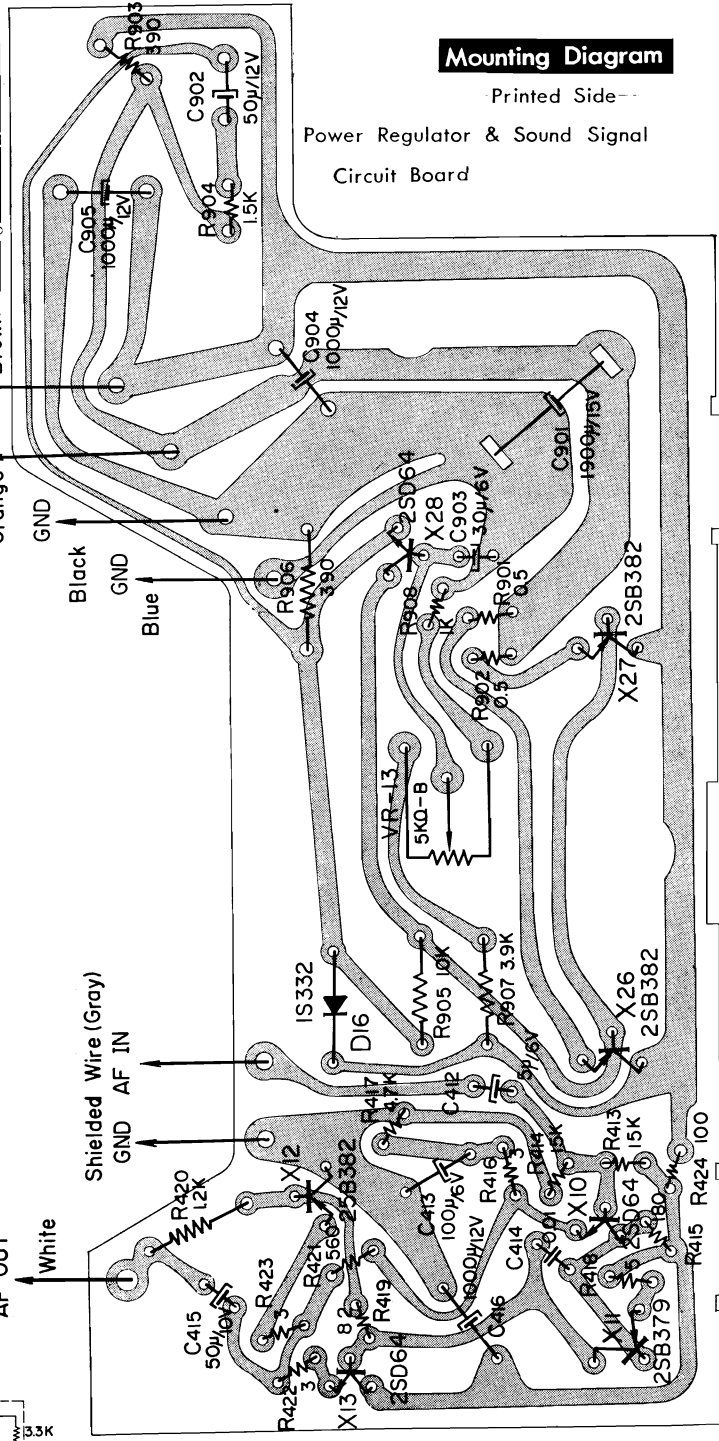
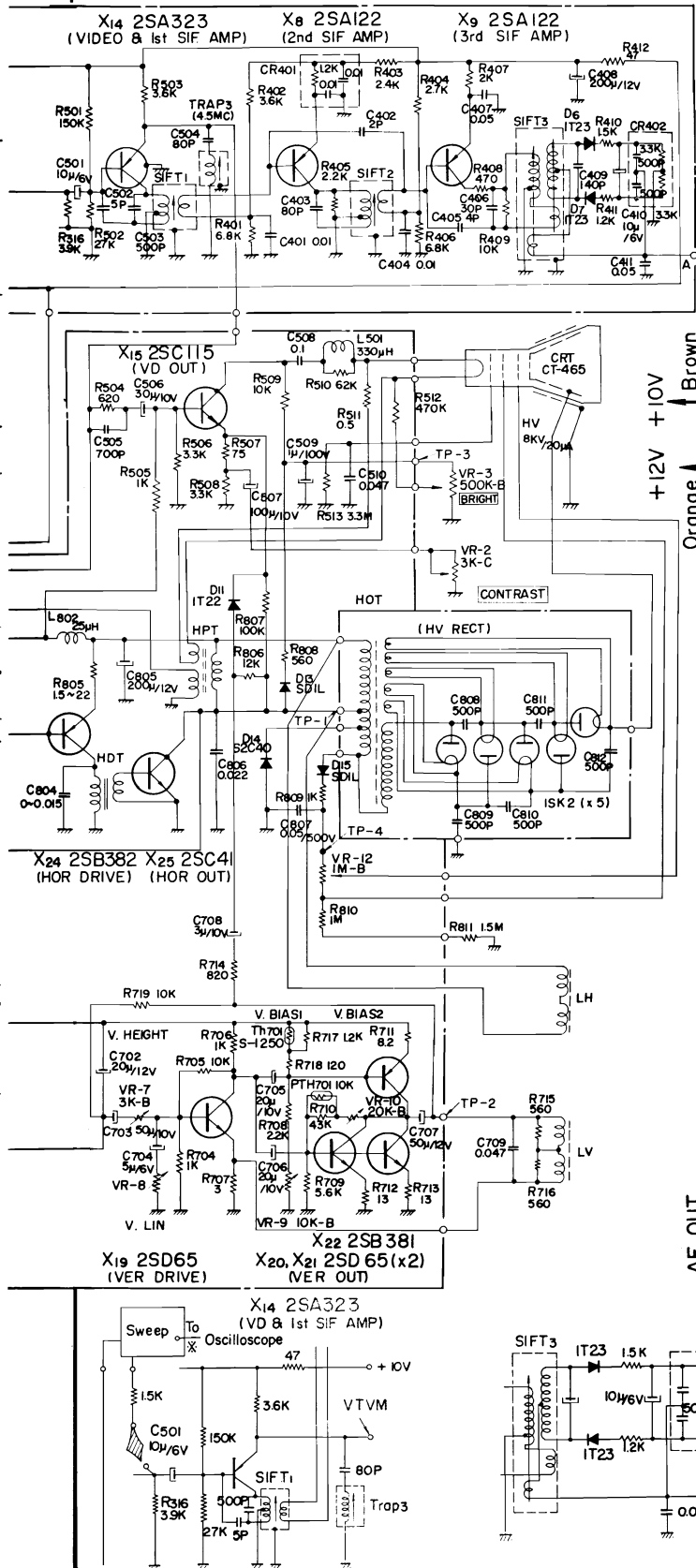

Mounting Diagram

Printed Side--

Power Regulator & Sound Signal
Circuit Board

(Fig. 25)

1965 TELEVISION SERVICING INFORMATION

SONY Model TV4-203UW Service Information
(Continued)

Mounting Diagram

— Printed Side —

— Deflection Circuit Board —

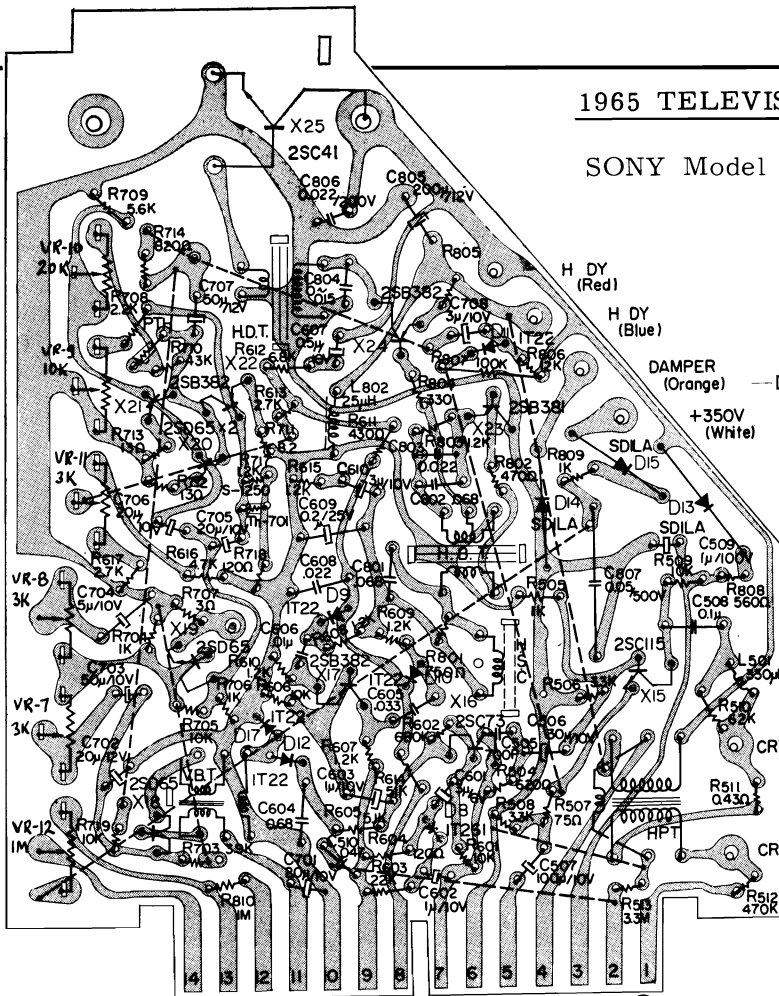

- To G3 of CRT (Focus) + 250V
- + 150V
- To VRs (Vert. Hold) + 10V
- To GND
- To VR4 (Hori. Hold)
- To Video Input
- To GND
- To VR2 (Contrast)
- Keyed Pulse + 45V
- To G1 of CRT
- To VR3 (Brightness)

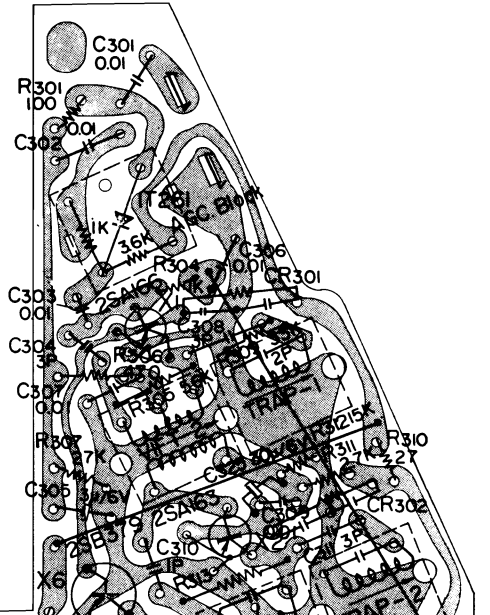

Mounting Diagram

— Printed Side —

— Video Signal Circuit Board —

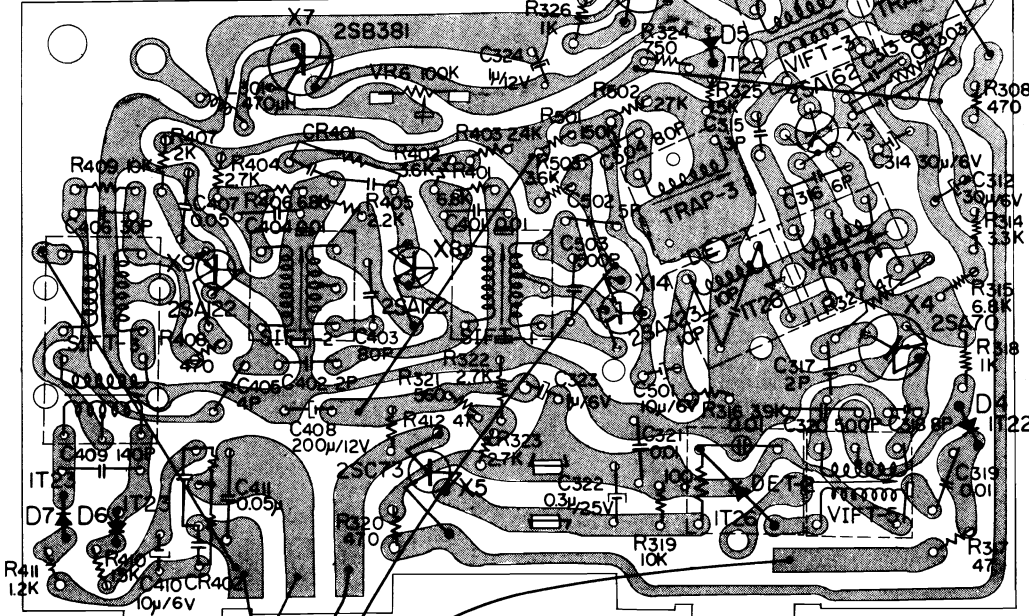

④③① 132
To 7P Connector

SYLVANIA

Chassis 584-1, -2, -3, -5, -6, -7, used in Models 19T30, -1, 19T31-1, -2, 19T32, -1, Also Chassis 583-1, -3, -4, -5, -6, are electrically practically identical to prior listed chassis, and are used in Models 19P16-1, 19P19-1, 19P36-1, 19P37, 19P38, 19P39, 19P40, 19P41; and Chassis 585-3, -4, -5, are also very similar to others, separate schematic diagram is on pages 136-137, and are used in Models 23H20, 23H30, 23T105, 23T106, 23T110, 23T111, 23L135-1, 23L159, 23L160, 23L161.

ADJUSTMENTS

CENTERING ADJUSTMENT

1. Position deflection yoke as far forward as possible on the neck (against the flare) of the picture tube.
2. Rotate centering adjustment rings (located on yoke cover) individually or together, until picture is centered. Turn brightness control to a low level and check that no corner cutting exists in the picture.

FOCUS

With contrast and brightness at normal settings connect focus jumper to either tie point X, Y, Z whichever gives maximum sharpness and clarity of fine detail in center and edges of picture.

HORIZONTAL AFC ADJUSTMENT

Before performing the following procedure, check AGC adjustment as described under controls.

1. Set channel selector to strongest channel in area and adjust fine tuning control to correct tuning point.
2. Adjust vertical height, vertical linearity and width control for normal picture.

3. Adjust **L400** Horizontal Stabilizing coil for 10 volt AC with hot lead of probe at horizontal test point **D**, ground lead to chassis, keeping picture locked in with **R414** Horizontal hold control as adjustment is being made.
4. Short pin 2 of V6 (10JT8) to ground and adjust **R414** until the picture becomes as stable as possible.
5. Remove short from V6, rotate channel selector to a position on which no signal is received; then return to the original station. The picture should immediately fall into sync. If not, repeat steps 3, 4 and 5.

HORIZONTAL LINEARITY

Before attempting to adjust Horizontal Linearity coil **L406**, make certain all other controls are adjusted for normal picture viewing. Using a test pattern, preferably a circle, rotate core of **L406** until it is all the way out. Then slowly turn core inward until the right hand side of test pattern (as viewed from the front) is pulled out to its maximum. When maximum is reached, reverse rotation of the core very slightly until both sides of the circle are linear. Final adjustment of the Vertical Height, Vertical Linearity and width controls may become necessary after adjusting **L406**.

CHASSIS REMOVAL

1. Disconnect AC power cord and antenna connections. Remove interlock cover.
2. Remove two (2) screws securing chassis to cabinet.
3. Pull out on lower control knobs until clear of respective shaft. *(These lower knobs are captivated to the cabinet and cannot be removed from the cabinet completely unless the retaining ring is cut. If replacement of knob becomes necessary cut retaining ring. Remove knob and replace with new knob and retaining ring.)*
4. Disconnect the following plug and socket connections.
 - A. Yoke - at chassis.
 - B. Tuner cluster - at chassis.
 - C. Picture Tube Cable - at picture tube.
 - D. High Voltage Lead - at picture tube
 - E. IF Input - at chassis.
 - F. Speaker Leads - at speaker
 - G. Wire Braid - at chassis.

5. Remove chassis mounting screws.
6. Slide chassis to rear until clear from cabinet.
7. Remove tuner cluster knobs by pulling straight outward.
8. Remove tuner mounting screw securing tuner cluster to cabinet.
9. Lift tuner cluster upward slightly and then back. Remove tuner cluster.
10. To replace chassis, reverse the above procedure, making certain to engage lower control knobs.

NOTE: To remove yoke, loosen screw on yoke retaining ring. Slide yoke to the rear until clear from the neck of the picture tube. To replace yoke reverse the above procedure, being careful not to strike the neck of the picture tube.

PICTURE TUBE REMOVAL

1. Remove chassis and tuner assembly as outlined under "Chassis Removal" procedure.
2. Lay cabinet face down on a soft material so as not to scratch or mar the face of the picture tube or finish on cabinet.
3. Remove the four brackets and screws securing picture tube

- to cabinet.
4. USING GOGGLES AND GLOVES, reach under face of tube and lift from cabinet, DO NOT GRASP NECK OF PICTURE TUBE AT ANY TIME.
5. To install picture tube, reverse the preceding steps. Exercise caution not to scratch face of picture tube.

VOLUME TV-24, ADDITIONAL 1965 TELEVISION SERVICING INFORMATION

SYLVANIA Chassis 583-1, 584-1, 585-3, etc., Alignment Information

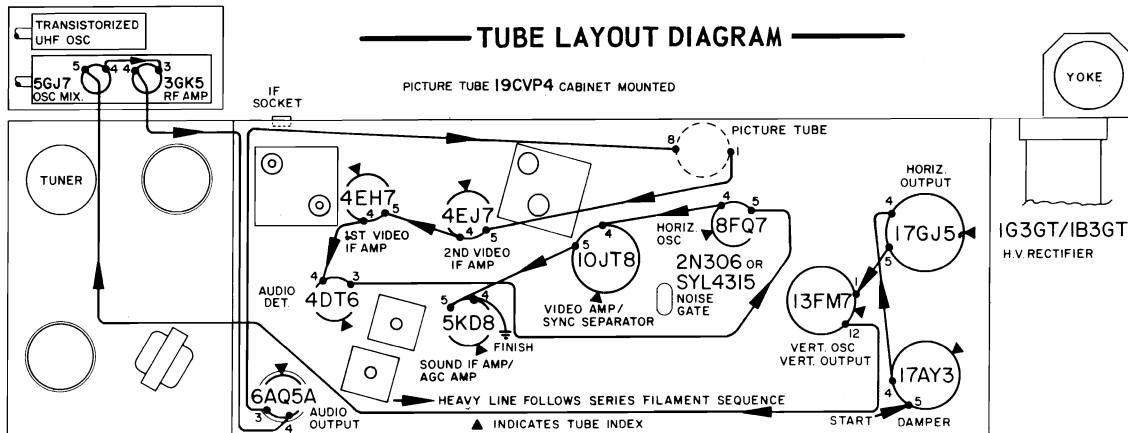

ALIGNMENT PROCEDURE

PRELIMINARY INSTRUCTIONS

1. Line voltage should be maintained at 120 volts.
2. Keep marker generator coupling at a minimum to avoid distortion of the response curve.
3. Do not use tubular capacitors for coupling sweep into receiver. Disc ceramics are best.
4. For best results, solder the sweep generator ground to chassis, do not use clips.
5. Sweep generator "hot" lead must make good electrical contact at all points given under TEST EQUIPMENT HOOK-UP.
6. Adjust sweep generator output for maximum peak-to-peak response curve on the scope.
7. Receiver and test equipment should warm up for approximately 15 minutes before alignment.

VIDEO IF ALIGNMENT

| STEP | ALIGNMENT SET - UP NOTES | TEST EQUIPMENT HOOK - UP | ADJUST |
|------|---|---|--|
| 1 | <p>Set VHF tuner to a free channel that does not disturb the response curve.</p> <p>Short point (B) to ground and connect a -10V DC source to tie point (2).</p> <p>Connect - 30 volt DC source (-) terminal to pin 2 of V10 (+) terminal to chassis.</p> | <p>SWEEP GENERATOR - Through a .002 MFD capacitor to pin 2 of V5. Set generator to 43.5 MC with 10 MC sweep.</p> <p>SIGNAL GENERATOR - Loosely coupled as a marker to sweep generator lead.</p> <p>OSCILLOSCOPE - Through a 10K resistor connected to test point (A)</p> | <p>L205 and L207 so that the 42.6 MC marker and the 45.75 MC marker are of equal amplitude. See Figure 1.</p> <p>L205 Positions marker amplitude. L207 Adjusts for tilt.</p> |
| 2 | <p>Same as Step 1.</p> <p>Figure 2</p> | <p>SWEEP GENERATOR - Through a .002 MFD capacitor to IF test point on tuner. Set generator to 43.5 MC with 10 MC sweep.</p> <p>SIGNAL GENERATOR - Same as Step 1.</p> <p>OSCILLOSCOPE - Same as Step 1.</p> | <p>T200 so that both the 42.6 MC and 45.75 MC markers are of equal amplitude and at 55% of response curve. See Figure 2.</p> |
| 3 | <p>Same as Step 1.</p> <p>Figure 3</p> | <p>SWEEP GENERATOR - Same as Step 2.</p> <p>SIGNAL GENERATOR - Same as Step 1.</p> <p>OSCILLOSCOPE - Same as Step 1.</p> | <p>L204 for maximum dip at 47.25 MC</p> <p>TUNER MIXER COIL - To position 45.75 MC marker at 50% of response curve while 45 MC marker is maintained at 100%.</p> <p>L202 To obtain response as shown in Figure 3. Top of response curve should be smooth and rounded and should rise from 105% to 120%.</p> |

VOLUME TV-24, ADDITIONAL 1965 TELEVISION SERVICING INFORMATION

SYLVANIA Chassis 583-1,+ , 584-1,+ , 585-3,+ , etc., Continued

ALIGNMENT PROCEDURE (CONTINUED)

— 4.5 MC TRAP AND SOUND IF ALIGNMENT —

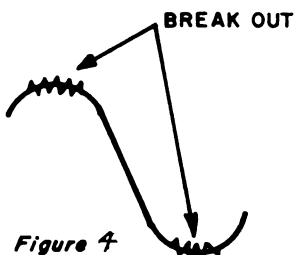
| STEP | ALIGNMENT SET - UP NOTES | TEST EQUIPMENT HOOK - UP | ADJUST |
|------|---|--|---|
| 1 | Set contrast control to maximum. Connect - 30 volts DC source (-) terminal to test point (B) and pin 2 of V10 (+) terminal to chassis. | SIGNAL GENERATOR - Through a .0047 MFD capacitor to test point (A). Set signal generator to 4.5 MC, preferably crystal calibrated or controlled, with at least 100 millivolts output. VTVM - Through detector network shown in Figure 4, to cathode of picture tube - tie point (36). | Separate cores of (T204) then Adjust top core of (T204) for minimum reading on meter. |
| 2 | Same as Step 1. | SIGNAL GENERATOR - Same as Step 1. VTVM - Through detector network shown in Figure 5, to pin 7 of 4DT6 | (T100) Bottom core (T100) Top core (T204) Bottom core For maximum meter reading using weakest possible signal. |
| 3 | Same as Step 1.  <i>Figure 4</i> | SIGNAL GENERATOR - Same as Step 1. OSCILLOSCOPE - Through .0047 MFD capacitor to tie point (41). | With core of (L100) at the top of coil form, rotate core inward (clockwise). (NOTE: Coil has two (2) peaks of resonance). Tune through the first peak and adjust the core for maximum amplitude on the second peak. Decrease signal strength until break out occurs, then readjust top core of (T100) until break out occurs simultaneously on both peaks. See Figure 6. |
| 4 | Remove all test equipment leads etc. Connect antenna and check receiver on a strong local station. | | |

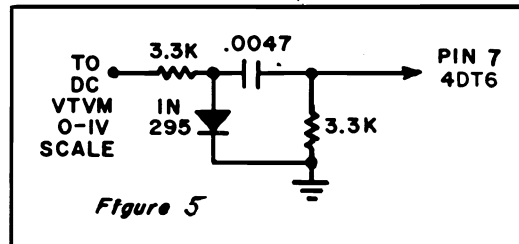
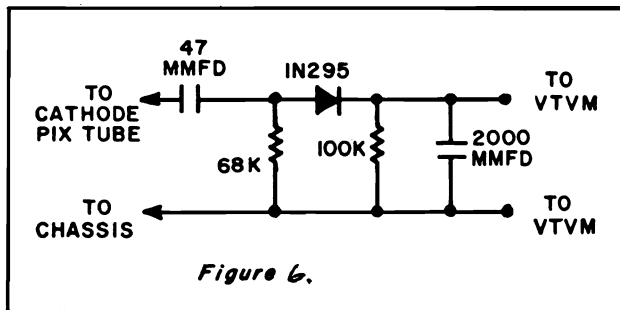

ALTERNATE SOUND ALIGNMENT USING TRANSMITTED SIGNAL

Tune in strongest available channel and adjust for best picture. Turn AGC control clockwise until picture begins to distort and adjust (L100) for best sound and minimum buzz. Use tuning point where core is closest to chassis board.

Turn AGC counterclockwise until sound gets weak and noisy. Adjust (T100) top and bottom core and (T204) bottom core for loudest and clearest sound and minimum hiss.

VOLUME TV-24, ADDITIONAL 1965 TELEVISION SERVICING INFORMATION

SYLVANIA Chassis 584-5, -6, -7, Schematic Diagram

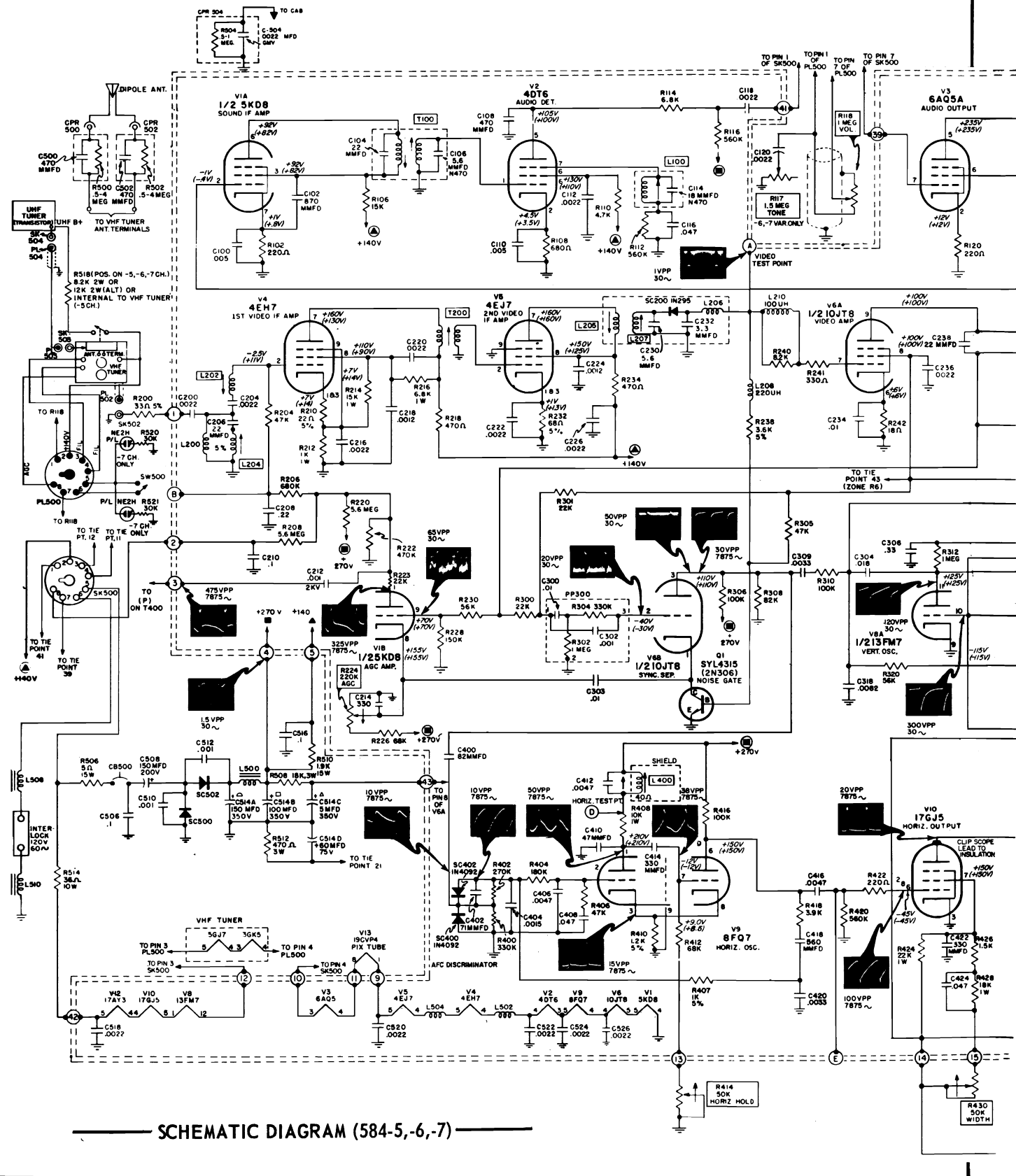

SCHEMATIC DIAGRAM (584-5,-6,-7)

VOLUME TV-24, ADDITIONAL 1965 TELEVISION SERVICING INFORMATION

SYLVANIA Chassis 584-5, -6, -7, Schematic Diagram, Continued

(Chassis 584-1, -2, -3, and 583-1, -3, -4, -5, have circuitry practically identical to this schematic diagram.)

— SCHEMATIC NOTES —

VOLTAGE MEASUREMENT CONDITIONS UNLESS OTHERWISE SPECIFIED.

1. Voltages measured to chassis using VTVM.
2. AC power source 120 volt 60 cycle line.
3. Voltage readings in brackets taken with no input; channel selector set to a free channel, antenna disconnected, antenna terminals shorted together and grounded to chassis.
4. Voltage readings not in brackets taken with a strong signal input; tuner set to a strong local station developing approximately -7 volt on AGC Buss. NOTE: AGC VOLTAGE AT TEST POINT (B) WILL VARY FROM -7 VOLT ON A VERY STRONG SIGNAL TO A +20 VOLT ON A VERY WEAK SIGNAL.
5. Contrast control set to maximum. Brightness control set to minimum.
6. Voltage values shown are average readings. Variations may be observed due to normal production tolerances.

SPECIAL VOLTAGE MEASUREMENT CONDITIONS

- Ⓛ Picture tube anode voltage measured with VTVM high voltage probe at line voltage of 120 volts under conditions of normal signal, no brightness and correct scan size.
- ▲ High peak voltage of short duration may damage meter used for this measurement.

WAVEFORM MEASUREMENT CONDITIONS

1. Channel selector set to strong channel.
2. Contrast control set for signal of 70 volt peak to peak at yellow lead of picture tube.
3. Waveforms measured with respect to chassis using a wide band oscilloscope. (Other type oscilloscopes may alter waveform shapes or amplitudes.)
4. The terms 30 ν or 7875 ν refer to scope frequency used.

— GENERAL SCHEMATIC NOTES —

1. Voltage sources are indicated by encircled symbols, corresponding symbols without circles indicate voltage tie points.
2. Average resistances of coils and transformers are shown and are measured with component connected in circuit.
3. Encircled numbers on edge of printed circuit indicate tie points, corresponding with those shown on parts layout of printed board.
4. All capacitors are in microfarads unless otherwise specified.
5. Coils, transformers, plugs and sockets are shown as viewed from the bottom.
6. Arrows on controls indicate direction of clockwise rotation.

— PARTS CODING —

| | |
|---------------------------|---------|
| Sound Section | 100-199 |
| Video Section | 200-299 |
| Vert. and Sync Section | 300-399 |
| Horiz. and H. V. Section | 400-499 |
| L. V. Supply, Fil., Misc. | 500-599 |

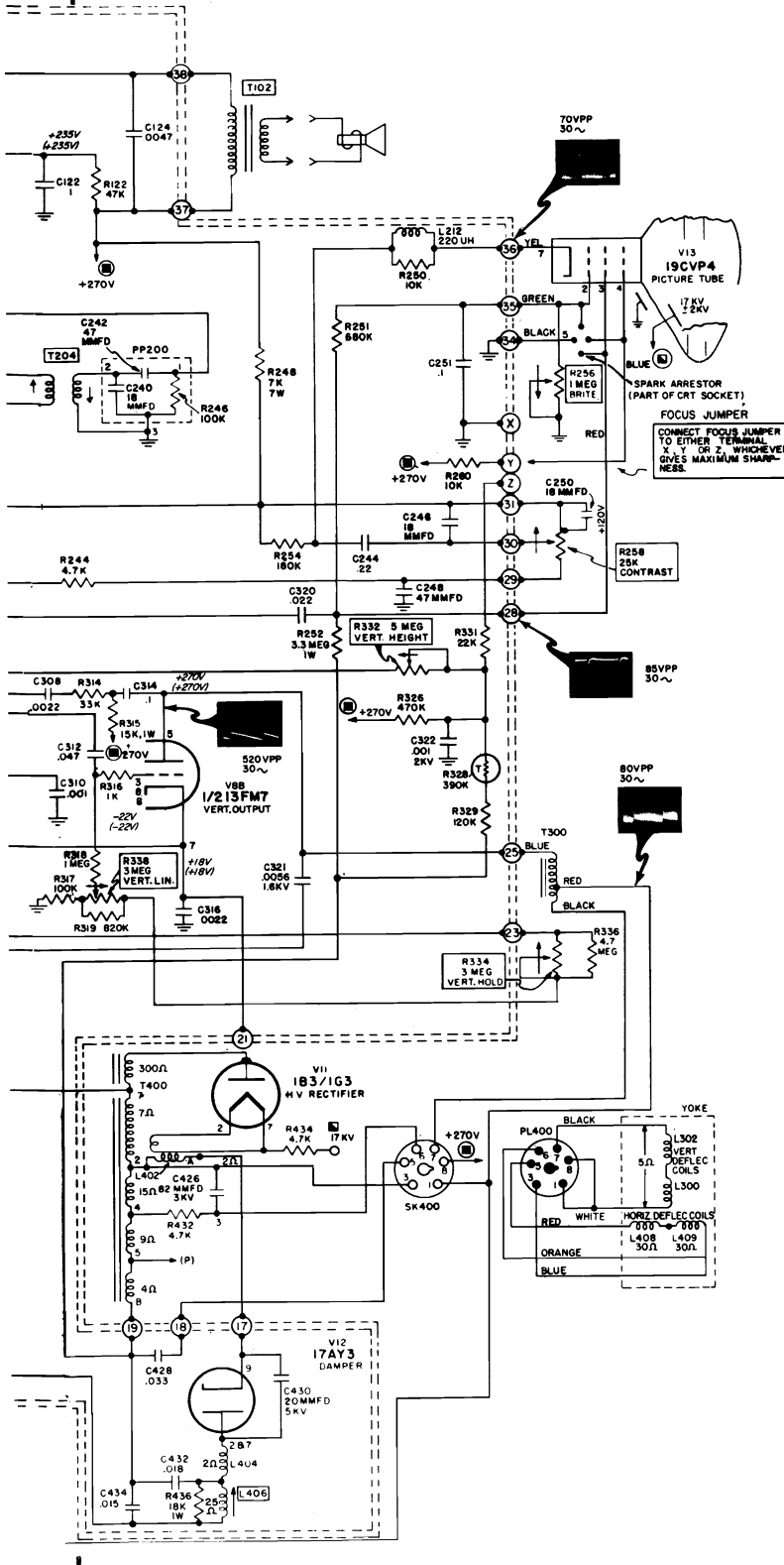

VOLUME TV-24, ADDITIONAL 1965 TELEVISION SERVICING INFORMATION

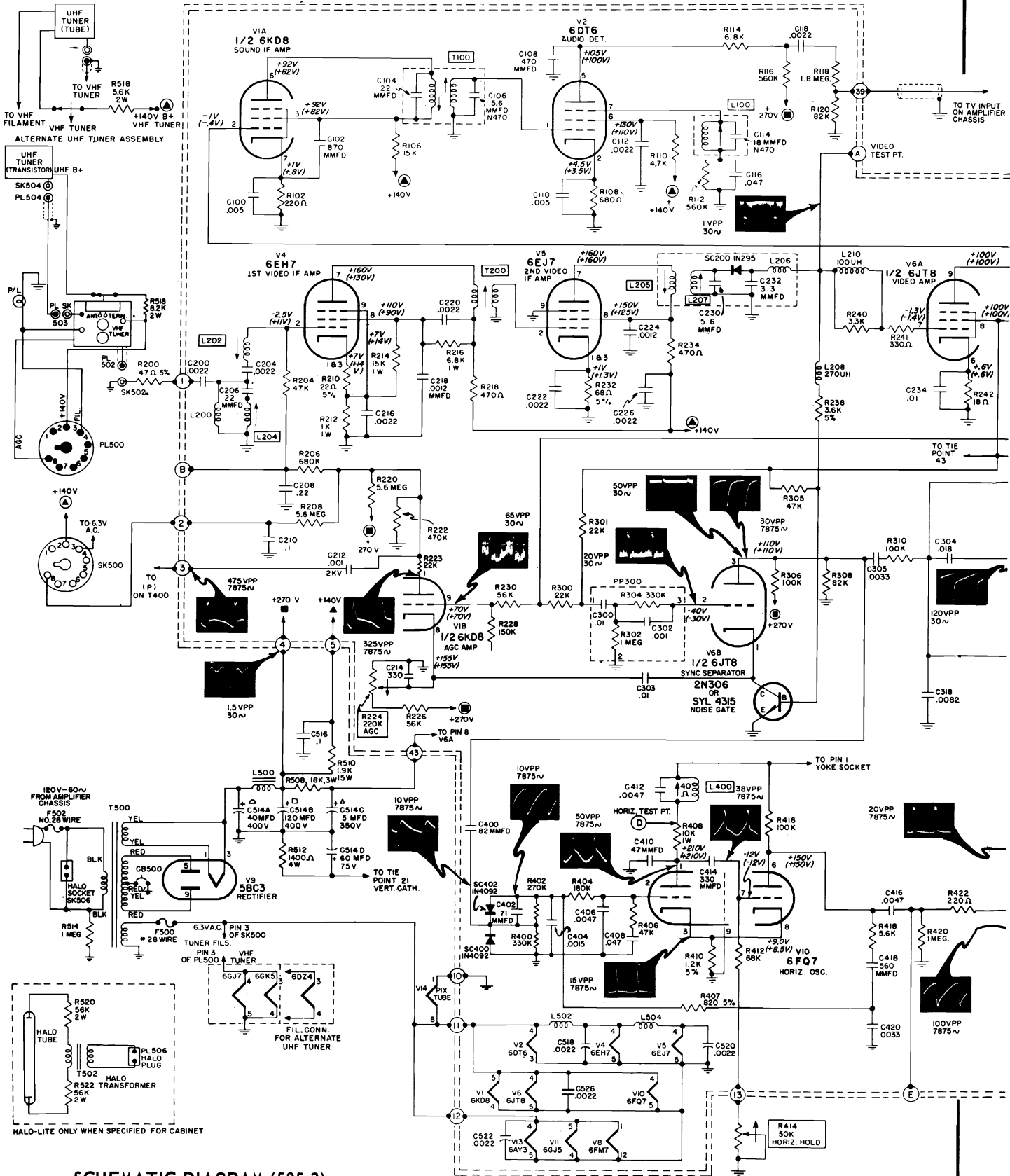

SCHEMATIC DIAGRAM (585-3)

VOLUME TV-24, ADDITIONAL 1965 TELEVISION SERVICING INFORMATION

SYLVANIA Chassis 585-3, -4, -5, Schematic Diagram, Continued

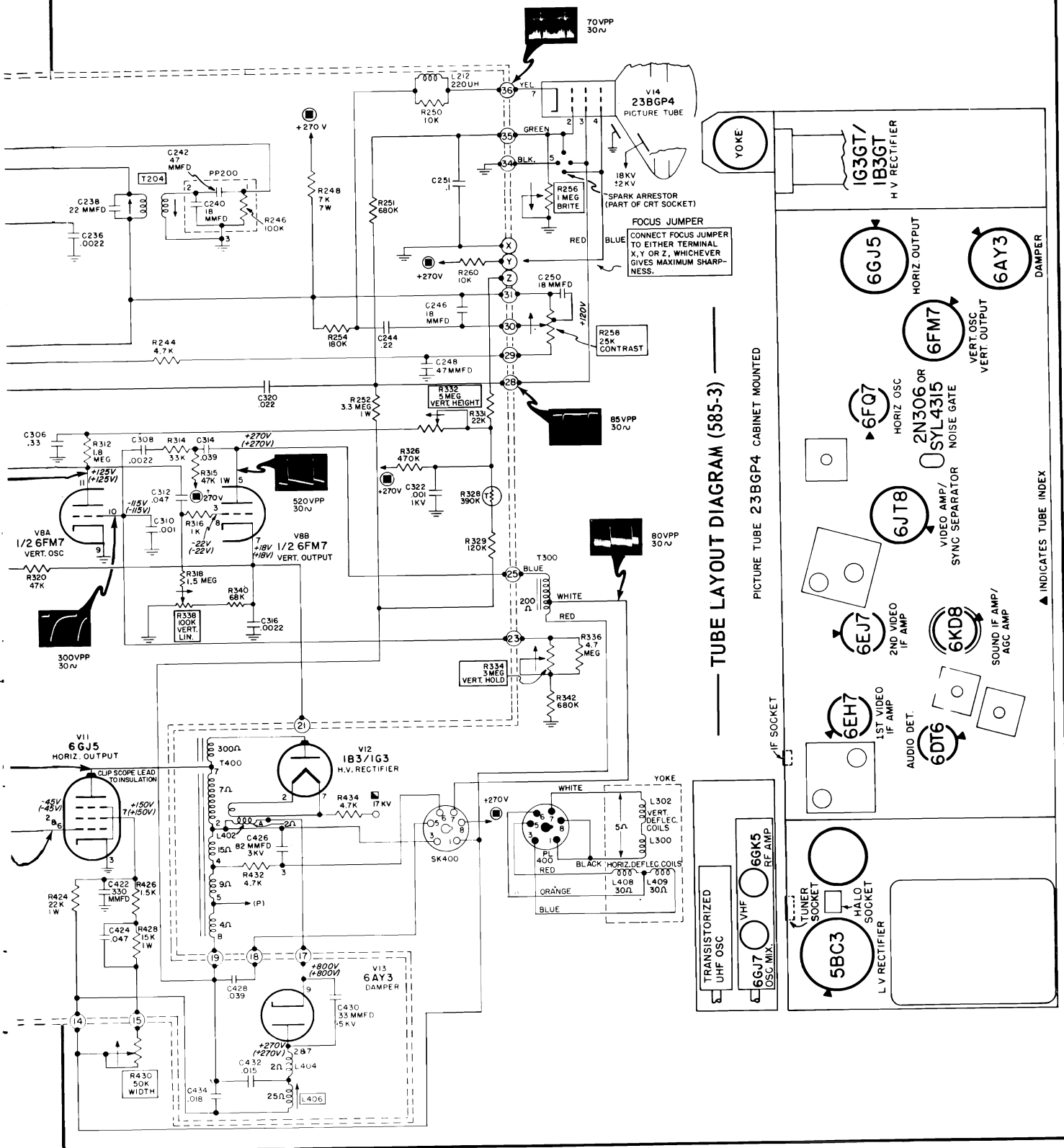

VOLUME TV-24, ADDITIONAL 1965 TELEVISION SERVICING INFORMATION

SYLVANIA

Chassis 584-1, -2, -3, -5, -6, -7,
(Continued)

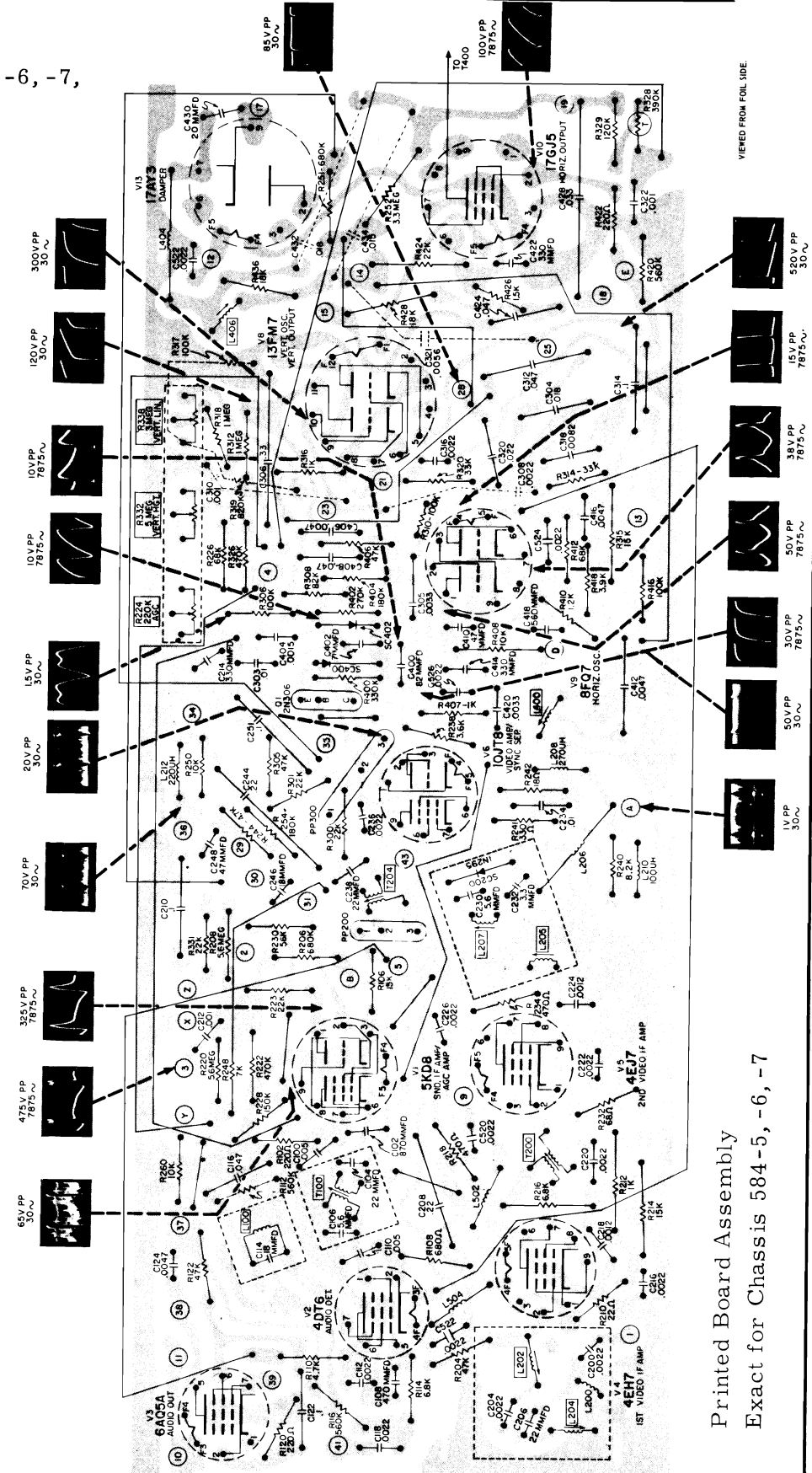
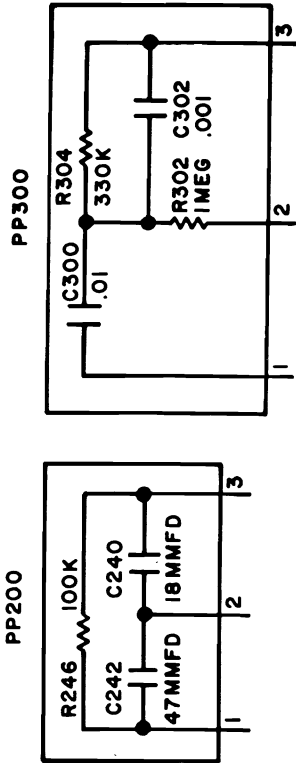

Printed Board Assembly
Exact for Chassis 584-5, -6, -7

SYLVANIA

Chassis 589-1 used in Models 23L144, 23L145, 23L146,
Chassis 589-3, -4, Models 23E01, 23E02, are electrically like above
sets except differ in audio output circuit and picture tube type.

ADJUSTMENTS

CENTERING ADJUSTMENT

1. Position deflection yoke as far forward as possible on the neck (against the flare) of the picture tube.
2. Rotate centering adjustment rings (located on yoke cover) individually or together, until picture is centered. Turn brightness control to a low level and check that no corner cutting exists in the picture.

FOCUS

With contrast and brightness at normal settings connect focus jumper to either tie point X, Y, Z whichever gives maximum sharpness and clarity of fine detail in center and edges of picture.

HORIZONTAL AFC ADJUSTMENT

Before performing the following procedure, check AGC adjustment as described under controls.

1. Set channel selector to strongest channel in area and adjust fine tuning control to correct tuning point.
2. Adjust vertical height, vertical linearity and width control for normal picture.

3. Adjust [L400] Horizontal Stabilizing Coil for 10 volt AC with hot lead of probe at horizontal test point (D), ground lead to chassis, keeping picture locked in with [R416] horizontal hold control as adjustment is being made.
4. Short pin 2 of V7 (6JT8) to ground and adjust [R416] until the picture becomes as stable as possible.
5. Remove short from V7, rotate channel selector to a position on which no signal is received; then return to the original station. The picture should immediately fall into sync. If not, repeat steps 3, 4 and 5.

HORIZONTAL LINEARITY

Before attempting to adjust Horizontal Linearity coil [L408], make certain all other controls are adjusted for normal picture viewing. Using a test pattern, preferably a circle, rotate core of [L408] until it is all the way out. Then slowly turn core inward until the right hand side of test pattern (as viewed from the front) is pulled out to its maximum. When maximum is reached, reverse rotation of the core very slightly until both sides of the circle are linear. Final adjustment of the Vertical Height, Vertical Linearity and width controls may become necessary after adjusting [L408].

CHASSIS AND PICTURE TUBE REMOVAL

CHASSIS REMOVAL

1. Disconnect AC power cord and antenna connections. Remove interlock cover.
 2. Disconnect the following plug and socket connections:
 - A. Yoke - at chassis.
 - B. Tuner cluster - at chassis.
 - C. Halo-Light (on some models) - at chassis.
 - D. Picture tube cable - at picture tube.
 - E. High voltage lead - at picture tube.
 - F. IF input - at chassis.
 - G. Speaker leads - at speaker.
 3. Remove screw securing braided cable grounding tuner assembly to main chassis.
 4. Remove chassis mounting screws.
 5. Slide chassis to the rear until clear of cabinet. **NOTE:** Lower front control knobs will automatically disconnect while chassis is being removed.
- NOTE:** To remove yoke loosen screw on deflection yoke retaining ring. Slide yoke back on neck of picture tube until clear from tube.
6. Remove tuner cluster knobs by pulling straight outward.
 7. Remove screws securing antenna board to cabinet.
 8. Remove tuner mounting screws securing tuner cluster to cabinet.
 9. Lift tuner cluster upward slightly and then back. Remove tuner cluster.
 10. To replace chassis, reverse the above procedure, engaging lower front controls by pressing ends of shaft assemblies over control shafts. Reconnect all plug and socket connections.

PICTURE TUBE REMOVAL

1. Remove chassis and tuner assembly as outlined under "Chassis Removal Procedure."

2. Lay cabinet face down on a soft material so as not to scratch or mar the face of the picture tube or finish on cabinet.
3. Remove the four brackets and screws securing picture tube to cabinet. **NOTE:** on models incorporating Halo-Light the halo transformer is mounted on one of the brackets securing the picture tube to cabinet. When removing picture tube on HaloLight models the bracket with the Halo transformer mounted on it need not be removed. Just loosen the screws and slip the tube out from under the bracket.
4. **USING GOGGLES AND GLOVES**, reach under face of tube and lift from cabinet. **DO NOT GRASP NECK OF PICTURE TUBE AT ANY TIME.**
5. To install picture tube, reverse the preceding steps. Exercise caution not to scratch face of picture tube.

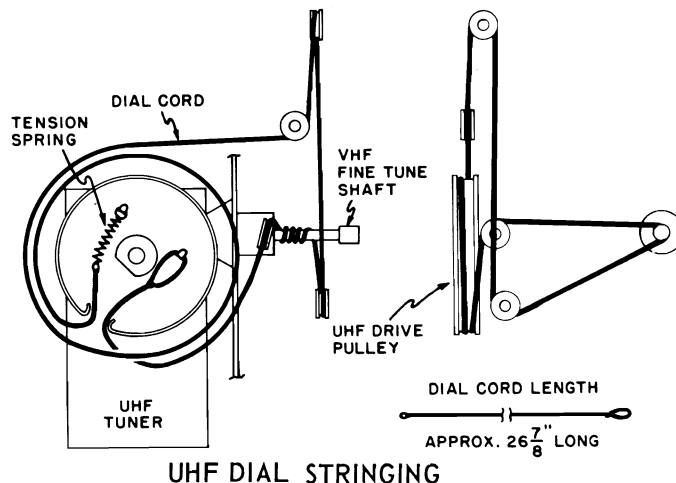

VOLUME TV-24, ADDITIONAL 1965 TELEVISION SERVICING INFORMATION

SYLVANIA Chassis 589-1, -3, -4, Alignment Information

VIDEO IF, SOUND IF AND 4.5 MC TRAP ALIGNMENT PROCEDURES

PRELIMINARY INSTRUCTIONS

1. Line voltage should be maintained at 120 volts.
2. Keep marker generator coupling at a minimum to avoid distortion of the response curve.
3. Do not use tubular capacitors for coupling sweep into receiver. Disc ceramics are best.
4. For best results, solder the sweep generator ground to chassis, do not use clips.
5. Sweep generator "hot" lead must make good electrical contact at all points given under TEST EQUIPMENT HOOK-UP.
6. Adjust sweep generator output for maximum peak-to-peak response curve on the scope.
7. Receiver and test equipment should warm up for approximately 15 minutes before alignment.

— VIDEO IF ALIGNMENT —

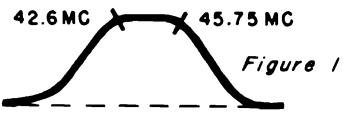
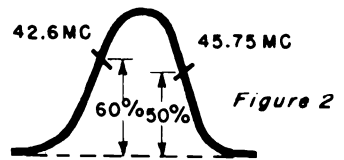
| STEP | ALIGNMENT SET-UP NOTES | TEST EQUIPMENT HOOK-UP | ADJUST |
|------|--|--|--|
| 1 | <p>Set VHF tuner to a free channel that does not disturb the response curve. Response curve should not change with fine tuning.</p> <p>Ground test point (A).</p> <p>Remove cap from horizontal output tube 6GJ5 to prevent the horizontal pulses from affecting the response curve.</p> | <p>SWEEP GENERATOR - through a .0047 MFD capacitor to point (E). Set generator to 44.5 MC with 10 MC sweep. Adjust sweep output for maximum without distorting curve.</p> <p>MARKER GENERATOR - Loosely coupled to sweep generator lead.</p> <p>OSCILLOSCOPE - Through a 33K resistor to point (C).</p> | <p>T204 Top and Bottom cores for maximum separation between cores.</p> <p>THEN</p> <p>Adjust both cores until the 42.6 MC and 45.75MC markers are equal in amplitude. Both markers should be positioned at 95% of the response curve, or better, but of equal amplitude.</p> <p>See Figure 1.</p> |
| 2 | <p>Same as Step 1.</p> <p>Detune tuner converter plate (IF output) coil by turning core fully counterclockwise.</p>  <p style="text-align: right;"><i>Figure 1</i></p> | <p>SWEEP GENERATOR - Through a .0047 MFD capacitor to point (B). Set generator to 44.5 MC with 10 MC sweep.</p> <p>MARKER GENERATOR - Same as Step 1.</p> <p>OSCILLOSCOPE - Same as Step 1.</p> | <p>A. Adjust T202 to position 45.75MC marker at 50%</p> <p>B. Adjust T200 to position 42.6 MC marker at 60%.</p> <p>Repeat Steps A, B to obtain response curve shown in Figure 2.</p> |
| 3 | <p>Same as Step 2.</p>  <p style="text-align: right;"><i>Figure 2</i></p> | <p>SWEEP GENERATOR - Through a .0047 MFD capacitor to IF test point on VHF tuner.</p> <p>MARKER GENERATOR - Loosely coupled to sweep generator.</p> <p>OSCILLOSCOPE - Same as Step 2.</p> | <p>A. Set marker generator at 47.25 MC. Adjust L203 for maximum dip.</p> <p>B. Set marker generator at 39.75 MC. Adjust L202 for maximum dip.</p> <p>C. Set signal generator at 41.25 MC and adjust L204 for minimum dip. See Figure 3.</p> |

ALTERNATE STEP 3 - Connect a VTVM on - DC scale to point (C). 1. Insert 47.25MC CW signal from signal generator to tuner test point. Adjust **L200** (Top core) and **L202** for minimum DC reading on meter. 2. Insert 41.25MC CW signal to tuner test point and adjust **L204** for minimum DC reading on meter.

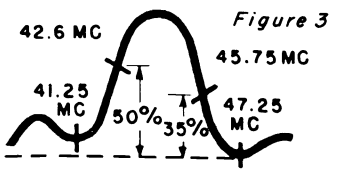
| | | | |
|---|--|---|--|
| 4 | <p>Same as Step 2.</p>  <p style="text-align: right;"><i>Figure 3</i></p> | <p>SWEEP GENERATOR - Same as Step 3.</p> <p>MARKER GENERATOR - Same as Step 3.</p> <p>OSCILLOSCOPE - Same as Step 3.</p> | <p>A. Adjust converter coil in tuner and L200 (Top core) to position 42.6 and 45.75 markers as shown in Figure 3.</p> <p>Repeat Step 3.</p> |
| 5 | <p>Remove all test equipment and replace cap on 6GJ5 tube. Check receiver on an air signal.</p> | | |

VOLUME TV-24, ADDITIONAL 1965 TELEVISION SERVICING INFORMATION

SYLVANIA Chassis 589-1, -3, -4, Alignment Information, Continued

ALIGNMENT PROCEDURE (CONTINUED)

4.5 MC TRAP AND SOUND IF ALIGNMENT

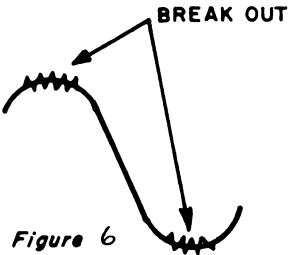
| STEP | ALIGNMENT SET - UP NOTES | TEST EQUIPMENT HOOK - UP | ADJUST |
|------|---|--|---|
| 1 | Set contrast control to maximum. Connect - 30 volts DC source (-) terminal to test point (A) and pin 2 of V12 (+) terminal to chassis. | SIGNAL GENERATOR - Through a .0047 MFD capacitor to test point (C). Set signal generator to 4.5 MC, preferably crystal calibrated or controlled, with at least 100 millivolts output. VTVM - Through detector network shown in Figure 4, to cathode of picture tube - tie point (18). | Separate cores of (T206) then Adjust top core of (T206) for minimum reading on meter. |
| 2 | Same as Step 1. | SIGNAL GENERATOR - Same as Step 1. VTVM - Through detector network shown in Figure 5, to pin 7 of 6DT6 | (T100) Bottom core (T100) Top core (T206) Bottom core For maximum meter reading using weakest possible signal. |
| 3 | Same as Step 1.  <i>Figure 6</i> | SIGNAL GENERATOR - Same as Step 1. OSCILLOSCOPE - Through .0047 MFD capacitor to tie point (25) | With core of (L100) at the top of coil form, rotate core inward (clockwise). (NOTE: Coil has two (2) peaks of resonance). Tune through the first peak and adjust the core for maximum amplitude on the second peak. Decrease signal strength until break out occurs, then readjust top core of (T100) until break out occurs simultaneously on both peaks. See Figure 6. |
| 4 | Remove all test equipment leads etc. Connect antenna and check receiver on a strong local station. | | |

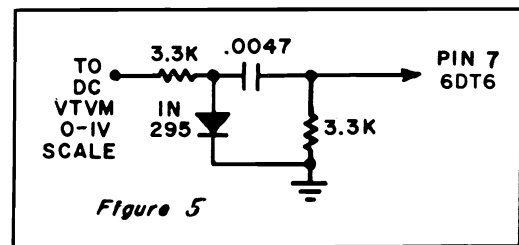
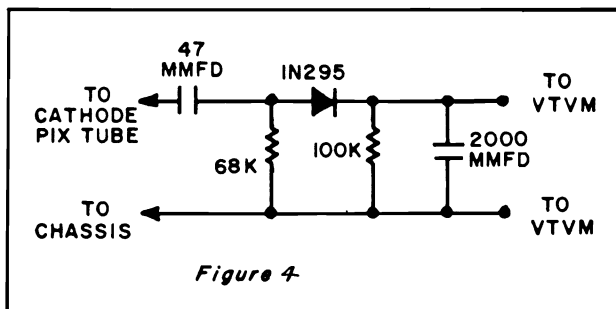

ALTERNATE SOUND ALIGNMENT USING TRANSMITTED SIGNAL

Tune in strongest available channel and adjust for best picture. Turn AGC control clockwise until picture begins to distort and adjust (L100) for best sound and minimum buzz. (Use tuning point where core is closest to chassis board.

Turn AGC counterclockwise until sound gets weak and noisy. Adjust (T100) top and bottom core and (T206) bottom core for loudest and clearest sound and minimum hiss.

SYLVANIA Chassis 589-1 Schematic Diagram

SYLVANIA Chassis 589-1 Schematic Diagram, Continued

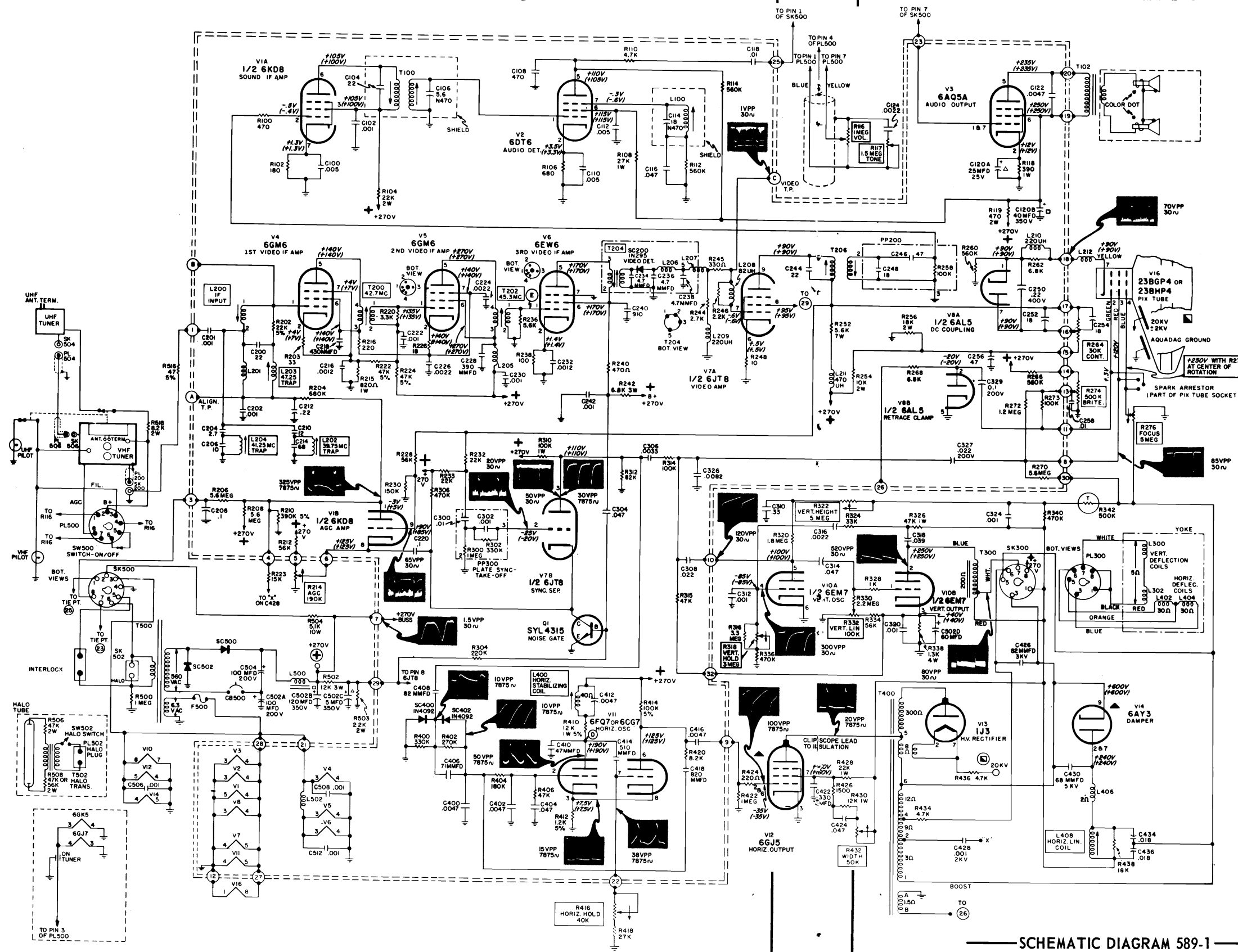

GENERAL SCHEMATIC NOTES

1. Voltage sources are indicated by encircled symbols, corresponding symbols without circles indicate voltage tie points.
2. Average resistances of coils and transformers are shown and are measured with component connected in circuit.
3. Encircled numbers on edge of printed circuit indicate tie points, corresponding with those shown on parts layout of printed board.
4. All capacitors are in microfarads unless otherwise specified.
5. Coils, transformers, plugs and sockets are shown as viewed from the bottom.
6. Arrows on controls indicate direction of clockwise rotation.

VOLTAGE MEASUREMENT CONDITIONS UNLESS OTHERWISE SPECIFIED.

1. Voltage measured to chassis using VTVM.
2. AC power source 120 volt 60 cycle line.
3. Voltage readings in brackets taken with no input; channel selector set to a free channel, antenna disconnected, antenna terminals shorted together and grounded to chassis.
4. Voltage readings not in brackets taken with a strong signal input; tuner set to a strong local station developing approximately -7 volt on AGC Buss. NOTE: AGC VOLTAGE AT TEST POINT ③ WILL VARY FROM -7 VOLT ON A VERY STRONG SIGNAL TO A +20 VOLT ON A VERY WEAK SIGNAL.
5. Contrast control set to maximum. Brightness control set to minimum.
6. Voltage values shown are average readings. Variations may be observed due to normal production tolerances.

SPECIAL VOLTAGE MEASUREMENT CONDITIONS

- ⑤ Picture tube anode voltage measured with VTVM high voltage probe at line voltage of 120 volts under conditions of normal signal, no brightness and correct scan size.
- ▲ High peak voltage of short duration may damage meter used for this measurement.

WAVEFORM MEASUREMENT CONDITIONS

1. Channel selector set to strong channel.
2. Contrast control set for signal of 70 volt peak to peak at yellow lead of picture tube.
3. Waveforms measured with respect to chassis using a wide band oscilloscope. (Other type oscilloscopes may alter waveform shapes or amplitudes.)
4. The terms 30N or 7875N refer to scope frequency used.

PARTS CODING

| | |
|--------------------------|---------|
| Sound Section | 100-199 |
| Video Section | 200-299 |
| Vert. and Sync Section | 300-399 |
| Horiz. and H.V. Section | 400-499 |
| L.V. Supply, Fil., Misc. | 500-599 |

SCHEMATIC DIAGRAM 589-1

VOLUME TV-24

SYLVANIA

Chassis 589-1, -3, -4,
Printed Board View

PP300

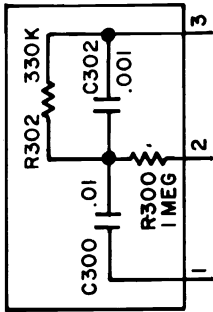

PP200

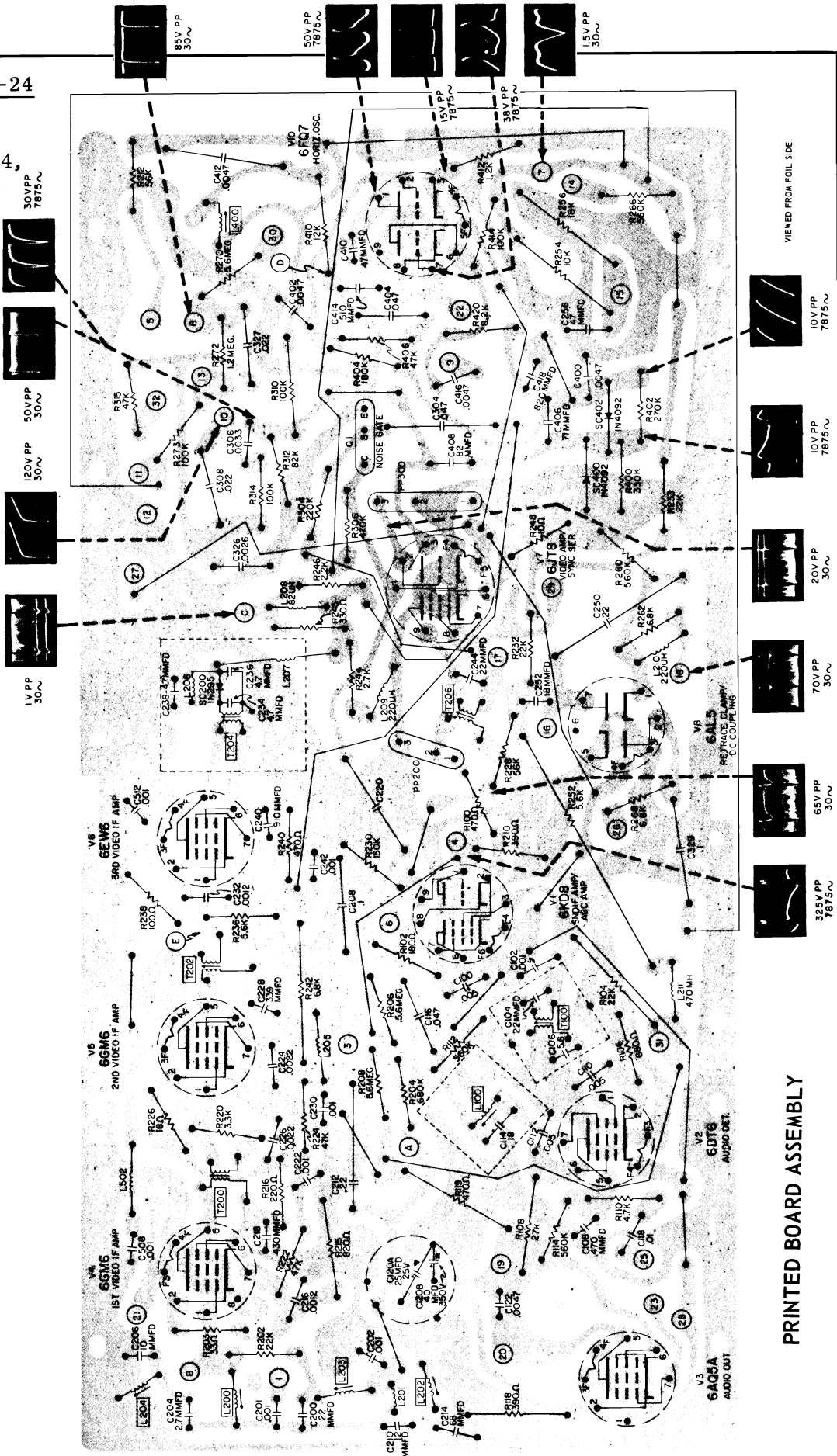
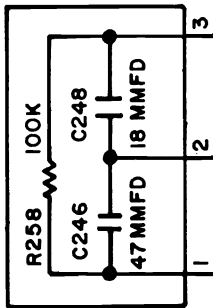

PRINTED BOARD ASSEMBLY

VIEWED FROM FOIL SIDE

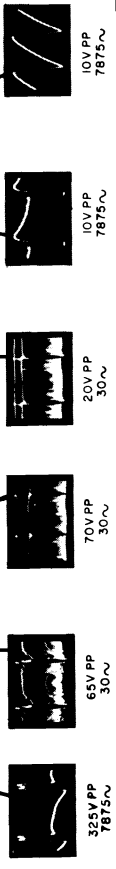
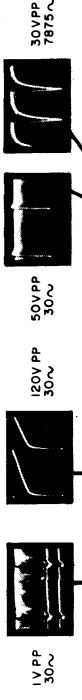

Westinghouse

CHASSIS V-2474

V-2474-1, -2, -3, -9 114° CRT-19CMP4
 V-2474-6, -7 114° CRT-19EJP4
 V-2474-11, -12, -13 94° CRT-23EJP4

(Material on pages 147 through 154)

MODEL AND CHASSIS CHART

| MODEL | CHASSIS | TUNERS | FEATURES | CRT |
|--|--|----------------------------------|---|----------------|
| H-P3029 H-P3030 | V-2474-1 | 472V045H01 UHF 470V149H01 VHF | | 19CMP4 114° |
| H-P3031 H-P3032 H-P3039 | V-2474-2 | 472V045H01 UHF 470V149H01 VHF | Instant On | 19CMP4 114° |
| H-P3035 | V-2474-3 V-2477-1 Remote | 472V046H01 UHF 470V148H01 VHF | Instant On Remote Control Pilot Light | 19CMP4 114° |
| H-P3250 | V-2474-6 | 472V045H01 UHF 470V149H01 VHF | Instant On | 19EJP4 114° |
| H-P3260 | V-2474-7 | 472V045H01 UHF 470V149H01 VHF | Instant On Pilot Light | 19EJP4 114° |
| H-K3690 H-K3693 H-K3840 H-K3841 | V-2474-11 | 472V046H01 UHF 470V149H01 VHF | | 23EJP4 94° |
| H-K3780 H-K3781 H-K3782 H-K3783 | V-2474-12 | 472V046H01 UHF 470V149H01 VHF | Instant On | 23EJP4 94° |
| H-C5240 | V-2474-13 V-2435-1 FM Stereo V-2515-18 AM-FM | 472V046H01 UHF 470V149H01 VHF | Instant On Stereo Phono AM-FM/FM Stereo Radio | 23EJP4 94° |

Additional Models H-P3022 and H-P3024, use Chassis V-2474-9, same as V-2474-2 except for unipole antenna in VHF input.

CHASSIS REMOVAL - PORTABLES

(The speaker and CRT remain in the cabinet.)

1. Remove the fully exposed control knobs (the Brightness and Vertical knobs are not removed.)
2. Disconnect the antenna leads and remove the back cover.
3. V-2474-3 ONLY:
 - a. Remove the remote switch by prying out the trimout fasteners.
 - b. Slide the remote receiver out from the cabinet. Disconnect CA400 and PL400. Unplug the lead to the transducer.
4. Unsolder the speaker leads at the output transformer.
5. Remove the CRT socket, yoke and width insert.
6. Discharge and disconnect the anode lead at the CRT.
7. Remove the chassis retaining screws (see Figure 1).
8. Carefully remove the chassis.

CHASSIS REMOVAL - 19" TRENDSETTER

1. Remove the control knobs.
2. Remove the back cover and antenna terminal board.
3. Unsolder the speaker leads at the output transformer.
4. Remove the 3 screws from the cabinet bottom. The isolation capristor comes out with the center screw.
5. Discharge the CRT and remove the HV lead, CRT socket,

width insert and yoke.

6. Remove these screws: 3 from the control panel, 1 from above the tuner, 1 from near the fuse, and 1 from near the high voltage cage. The control panel and tuners come out with the chassis.

CHASSIS REMOVAL - 23" TABLE MODELS AND CONSOLES

1. Remove the fully exposed front knobs.
2. Remove the cover over the B and V thumbwheels as follows: The bottom of the escutcheon is spring-loaded, and will partially move away from the cabinet. Pull the bottom of the escutcheon away from the panel until the thumbwheel cover can be slid down and removed.
3. Remove the back cover and the antenna terminal board. Unhook dag spring.
4. Unsolder the speaker leads at the output transformer.
5. Remove the tuner and control panel assy(s) after removing their retaining screws.
6. Remove the screws from the chassis brackets.
7. Remove the two screws that hold the chassis to the bottom of the cabinet.
8. Remove the CRT socket, yoke and width insert.
9. Discharge and disconnect the anode lead at the CRT.
10. Carefully remove the chassis.

VOLUME TV-24, ADDITIONAL 1965 TELEVISION SERVICING INFORMATION

WESTINGHOUSE Chassis V-2474-1, -2, etc. Service Information, Continued

PC BOARD ACCESSIBILITY

To provide access to the underside of the PC board with the set operating:

1. Remove the chassis.
2. Turn the chassis around.
3. Connect the yoke and width insert, CRT socket, and high-voltage lead (use a jumper).

A test speaker may be connected to the audio output transformer.

CAUTION: To operate the set partially disassembled, connect a jumper from the aquadag CRT coating to chassis ground. Be careful that the high-voltage anode lead does not short or arc to the frame.

HORIZONTAL RANGE AND HOLD ADJUSTMENT

1. Short out Horizontal Hold coil L401 with a jumper connected across 'G' & 'H'.
2. With the meter zero set at center scale, connect a VTVM (1.5V range) across 'F' and B-.
3. Tune the receiver to a station of normal signal strength, and adjust Horizontal Range control R413 to lock the picture into sync. Then adjust R413 for -0.25 volts on the VTVM.
4. Remove the jumper across 'G' & 'H', and adjust Horizontal Hold control L401 to lock the picture into sync.
5. Adjust L401 for -0.25 volts on the VTVM, and disconnect the VTVM.
6. Verify the horizontal sync adjustment by switching channels.

CENTERING

The centering rings, located at the rear of the deflection yoke, should be rotated to center the raster.

DEFLECTION YOKE

The deflection yoke should be as far forward as possible (touching the bell of the CRT). Rotation of the deflection yoke is used to level the raster.

WIDTH ADJUSTMENT

This adjustment is a plastic tab with a copper rectangle bonded on to one side. It protrudes out from between the yoke and the bottom of the neck of the picture tube. The shiny side of the copper rectangle goes up against the picture tube. The rectangle must be centered at the bottom of the CRT neck.

To adjust the width, loosen the yoke clamp. Pushing the tab into the yoke decreases width. Pulling the tab out of the yoke increases width. Best linearity, however, is possible with the width tab pushed all the way in. If insufficient width occurs, pull out the tab for just enough scan without causing poor linearity.

HEIGHT AND VERTICAL LINEARITY

The Height and Vertical Linearity controls are located on the PC board, and are accessible when the back cover of the set is removed (refer to Figure 10).

With a narrow screwdriver, adjust these controls alternately until a picture of proper height and linearity is obtained.

AGC ADJUSTMENT

Tune in the strongest station. Adjust C420 with an insulated screwdriver until the picture bends at the top. Then turn the screw back slightly until the bend disappears.

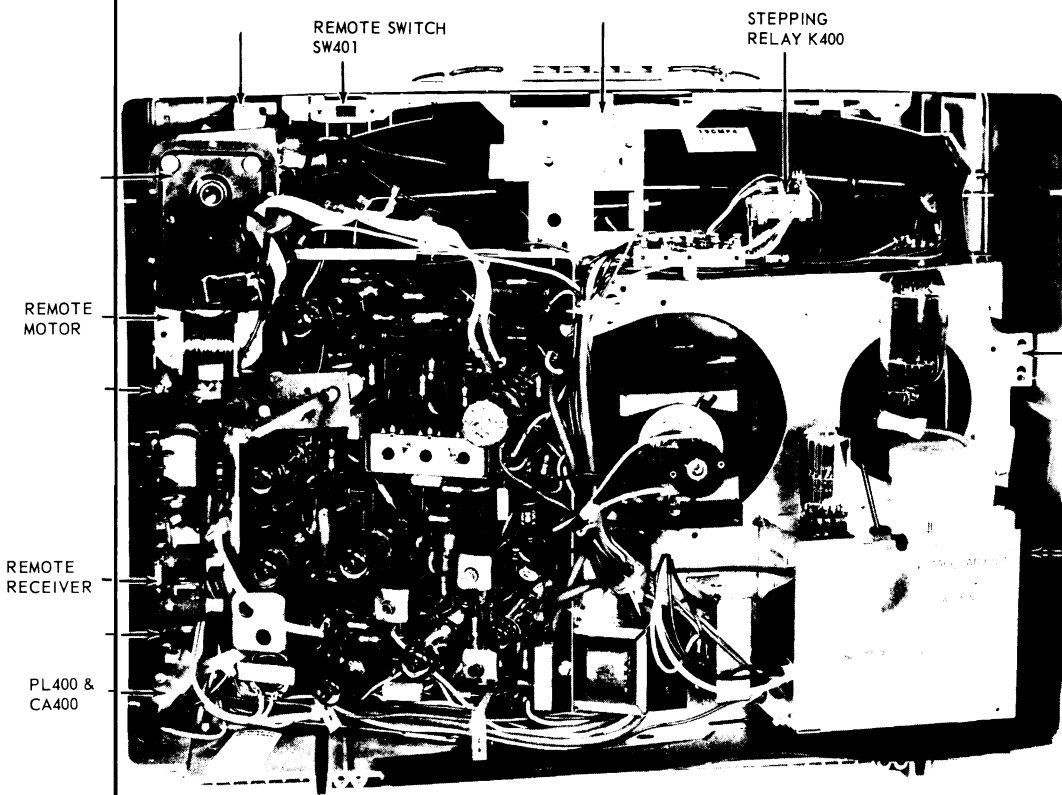

PC BOARD LEGEND

1. Pin #3 of CRT
2. Tuner filament
3. 135 B+ to tuner
4. Pin #2 of 21GY5, Horiz Drive
5. IF input from tuner
6. Tuner AGC
7. C403A, 130V, B+
8. R217 bottom, Contrast
9. Arm of R108, Volume
10. C420 & C419, AGC pulse
11. L400 & L404A, B+
12. C402A & R219 top, Brightness
13. AC tie point } Instant On Chassis
14. AC tie point }
15. Pin #8 of CRT } 23" Chassis
16. Tuner filament }
17. SW400
18. Pin #1 of 17BE3 damper
19. R217 top, Contrast
20. R108 top, Volume
21. R217 arm, Contrast
22. Pin #7 of CRT
23. Boost B+, 450V
24. R219 arm, Brightness
25. R416, B+
26. L402, B+
27. C405A, B+
28. T300, vert trans, red lead, B+
29. Pin #1 of 21GY5, filament
30. R310, Vert Hold
31. T300, vert trans, blue lead
32. T300, vert trans, orange lead, sec.

Figure 1. Rear View of remote portable showing location of screws for chassis removal.

VOLUME TV-24, ADDITIONAL 1965 TELEVISION SERVICING INFORMATION

WESTINGHOUSE Chassis V-2474-1, -2, etc. Service Information, Continued

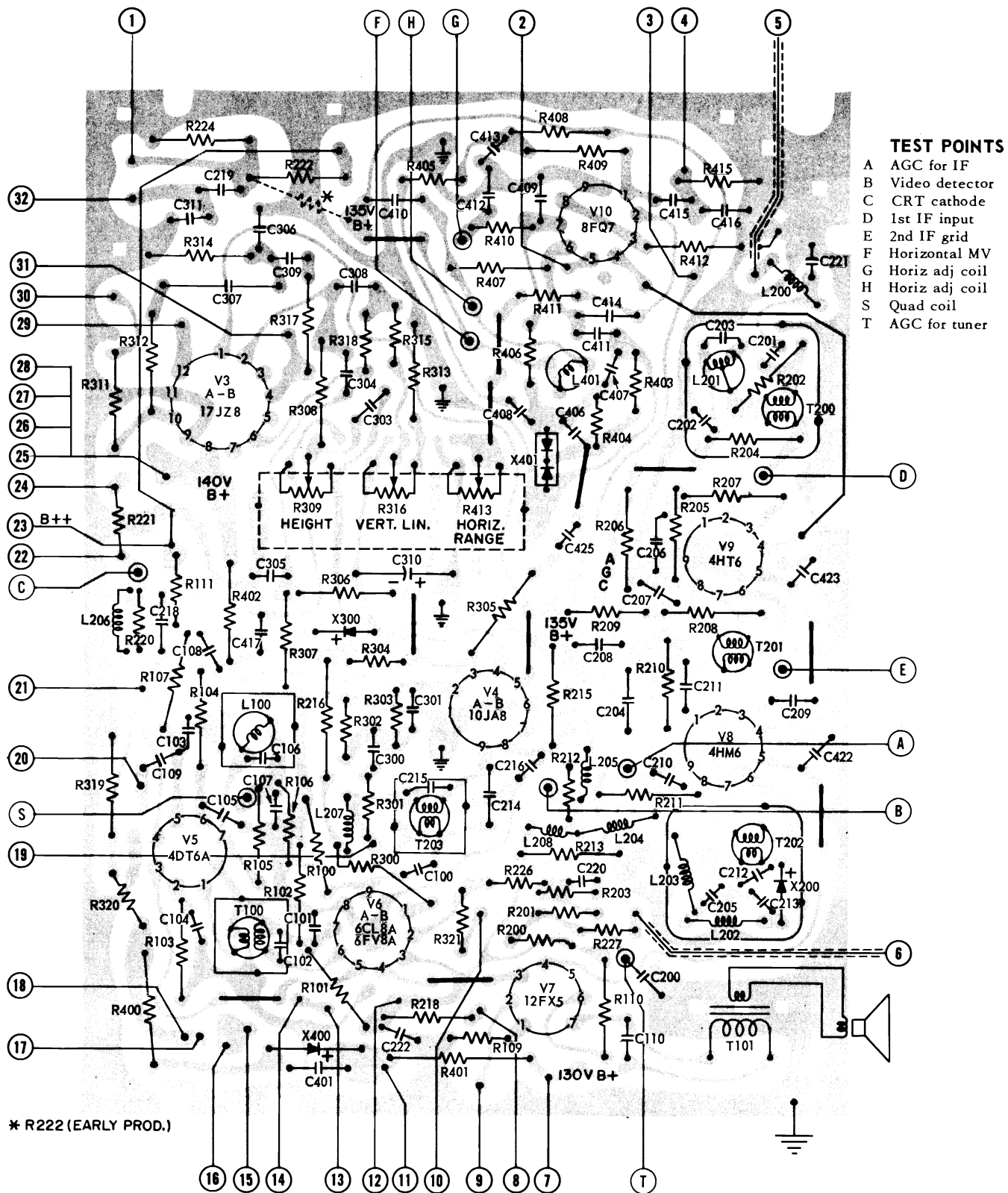

Figure 5. Bottom view of PC board. Top components are shown in solid outline. Tube pin numbering is for bottom of socket.

VOLUME TV-24, ADDITIONAL 1965 TELEVISION SERVICING INFORMATION

WESTINGHOUSE Chassis V-2474-1, -2, -3, -6, -7, Schematic Diagram

NOTES:

1. ALL CAPACITOR VALUES LESS THAN 1 ARE IN MFD. AND VALUES GREATER THAN 1 ARE IN PF (MICROMICROFARADS) ALL RESISTANCE VALUES ARE IN OHMS 1/2 WATT UNLESS OTHERWISE INDICATED.
2. DC VOLTAGES ARE MEASURED FROM POINT INDICATED TO CIRCUIT GROUND WITH A VTVM. LINE VOLTAGE AT 120 V.A.C., NO SIGNAL APPLIED.
3. WAVEFORMS WERE TAKEN WITH CONTROLS SET FOR A NORMAL PICTURE.
4. FOR VARIATION IN V2474-3 REMOTE CHASSIS SEE SUPPLEMENTAL SCHEMATIC.
5. FOR UHF TUNER - R225
472V045H01-3.3K
472V046H01-6.8K
472V049H01-6.8K
6. FOR V2474-1, -2, -3 CHASSIS V13 IS 19CMP4.
V2474-6, -7 CHASSIS V13 IS 19EJP4.

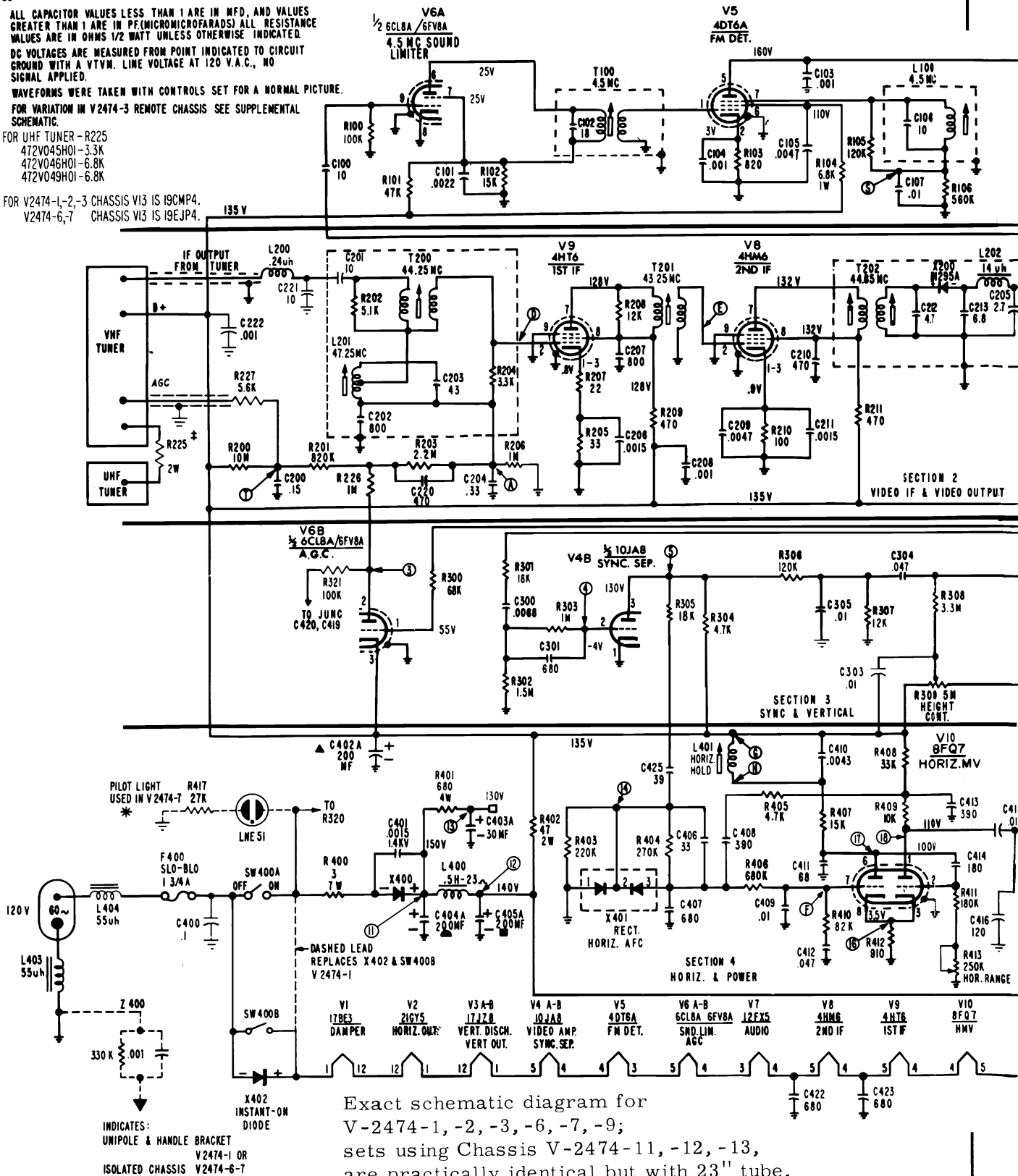

VOLUME TV-24, ADDITIONAL 1965 TELEVISION SERVICING INFORMATION
 WESTINGHOUSE Chassis V-2474-1, -2, -3, -6, -7, Schematic Diagram, Continued

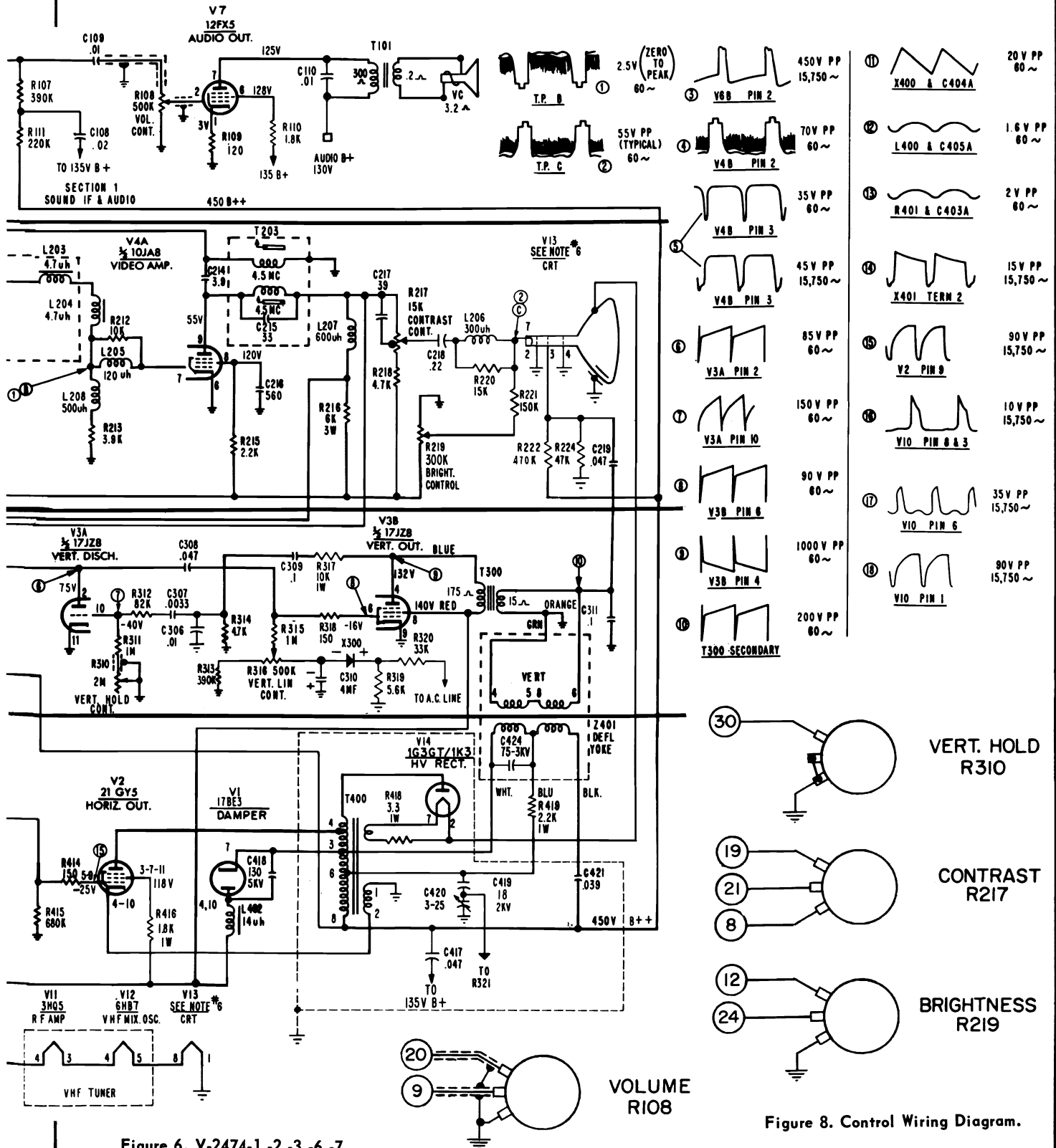

Figure 6. V-2474-1,-2,-3,-6,-7.

Figure 8. Control Wiring Diagram.

VOLUME TV-24, ADDITIONAL 1965 TELEVISION SERVICING INFORMATION

WESTINGHOUSE Chassis V-2474-1, -2, etc. Service Information, Continued

REMOTE CONTROL TRANSMITTER

With the remote control transmitter, you can: (1) turn the set on and off and adjust the volume, and (2) change channels in one direction.

The transmitter is a mechanical device consisting of two aluminum-alloy rods and two spring-operated striking mechanisms.

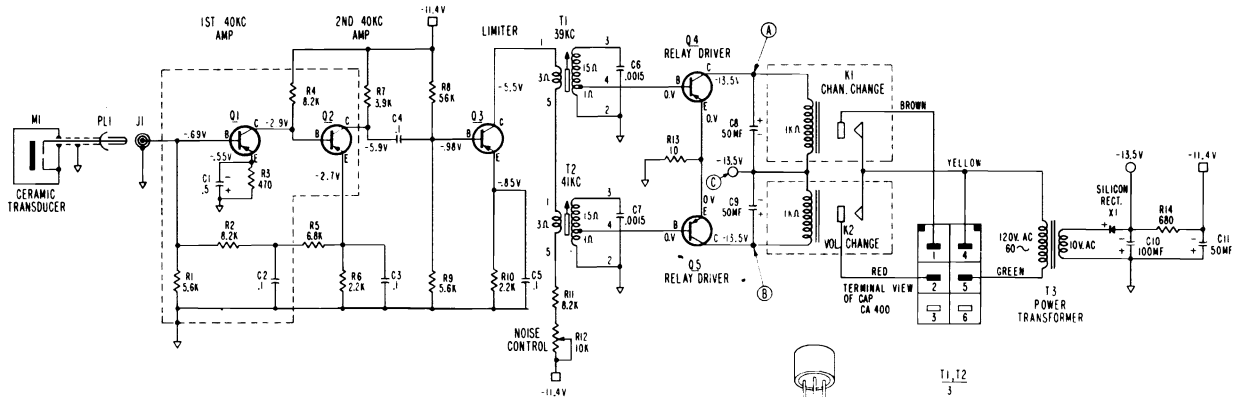

NOTES:

- ALL CAPACITANCE IN MF., ALL RESISTANCE VALUES IN OHMS 1/2 WATT, UNLESS OTHERWISE SPECIFIED.
- DC VOLTAGES MEASURED FROM POINT INDICATED TO G-, USING A VTVM LINE VOLTAGE AT 120V 60- HZ UNAPPLIED SIGNAL.
- CAUTION!
⊕ DENOTES REMOTE RECEIVER B-, TO PREVENT A SHOCK HAZARD, THE TV AND REMOTE RECEIVER B- MUST NEVER BE CONNECTED TO EACH OTHER UNDER ANY CIRCUMSTANCES.

| TRANSISTOR COMPLEMENT | | | | |
|-----------------------|--------------|----------|------------|--|
| FUNCTION | TYPE | PART NO. | ALTERNATE | |
| Q1 | 1ST 40KC AMP | P.N.P. | 2F1V032M01 | |
| Q2 | 2ND 40KC AMP | P.N.P. | 2F1V032M01 | |
| Q3 | LIMITER | P.N.P. | 2F1V032M01 | |
| Q4 | RELAY DRIVER | P.N.P. | 2F1V032M01 | |
| Q5 | RELAY DRIVER | P.N.P. | 2F1V032M01 | |

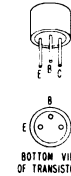

Remote Receiver Schematic.

ALIGNMENT

SOUND ALIGNMENT

EQUIPMENT: VTVM PROCEDURE:

- Select the strongest station available (preferably with test pattern and test tone) and adjust the FINE TUNING for best reception. Adjust the VOLUME control so that the station sound is audible.
- Adjust the quad coil (L100) for maximum sound from the speaker.
- Disconnect the antenna. Use a jumper wire to short TPⓄ to B-.
- Connect the VTVM to TPⓄ.
- Adjust interstage transformer T100 for maximum negative voltage on the VTVM.
- Remove the jumper wire used to Short TPⓄ to B-.
- Place the antenna input close to the antenna terminals so that the signal is loosely coupled to the receiver and the picture is barely visible. A pronounced noisiness (hiss)

should accompany the sound.

- Adjust the limiter input coil (T203 top slug) for maximum negative voltage on the VTVM. If the VTVM indicates a broad response while making this adjustment, the receiver input signal is too strong. When the signal coupling described in step 7 is at the necessary low point, no limiting takes place and the VTVM will indicate a sharp response to the limiter input coil adjustment.

4.5 MC TRAP ALIGNMENT

Disconnect the antenna and turn contrast control to maximum clockwise. Inject a 4.5 MC CW signal through a .001mf capacitor to TPⓄ. Connect a .001mf capacitor to a demodulation probe tip. Connect the other end of the probe to a VTVM and the capacitor to TPⓄ. Set the VTVM to 1.5-2V DC range. Turn the set on and allow ten minutes for warmup. Then adjust T203 bottom slug for minimum on the VTVM.

IF ALIGNMENT

EQUIPMENT

- Sweep Generator with a 10 MC wide sweep at center frequencies from 10 MC to 90 MC and 170 MC to 216 MC.
- CW (Marker) Generator which accurately produces the IF and RF frequencies from 4.5 MC to 216 MC.
- Oscilloscope with good low frequency response characteristics.
- VTVM.
- Bias Supply of -2.0 volts and -3 volts.
- Standard Alignment Tool with a 3/32" hexagonal tip (long enough to reach bottom slugs).

TERMINATION AND ADJUSTMENT OF EQUIPMENT

These instructions on termination and adjustment of equipment will apply throughout the IF Alignment procedure.

All test equipment cables and leads should be as short and direct as possible.

Oscilloscope and VTVM - Use a low-capacitance direct probe terminated with the decoupling network shown in Figure 13. Keep the oscilloscope calibrated for 2 volts peak to peak (P-P). Use a VTVM range suitable for measuring -1.5 volts.

Generators - Except where otherwise noted, all signal generating equipment should be terminated as shown in Figure 12. Connect the signal cable ground near the ground of the stage where the signal is injected.

Adjust the CW generator output so that: (1) When the VTVM is being used its reading remains near the -1 volt point. (2) When the oscilloscope is being used, the marker frequencies do not distort the response curve.

VOLUME TV-24, ADDITIONAL 1965 TELEVISION SERVICING INFORMATION
 WESTINGHOUSE Chassis V-2474-1, -2, etc. Alignment Information, Continued

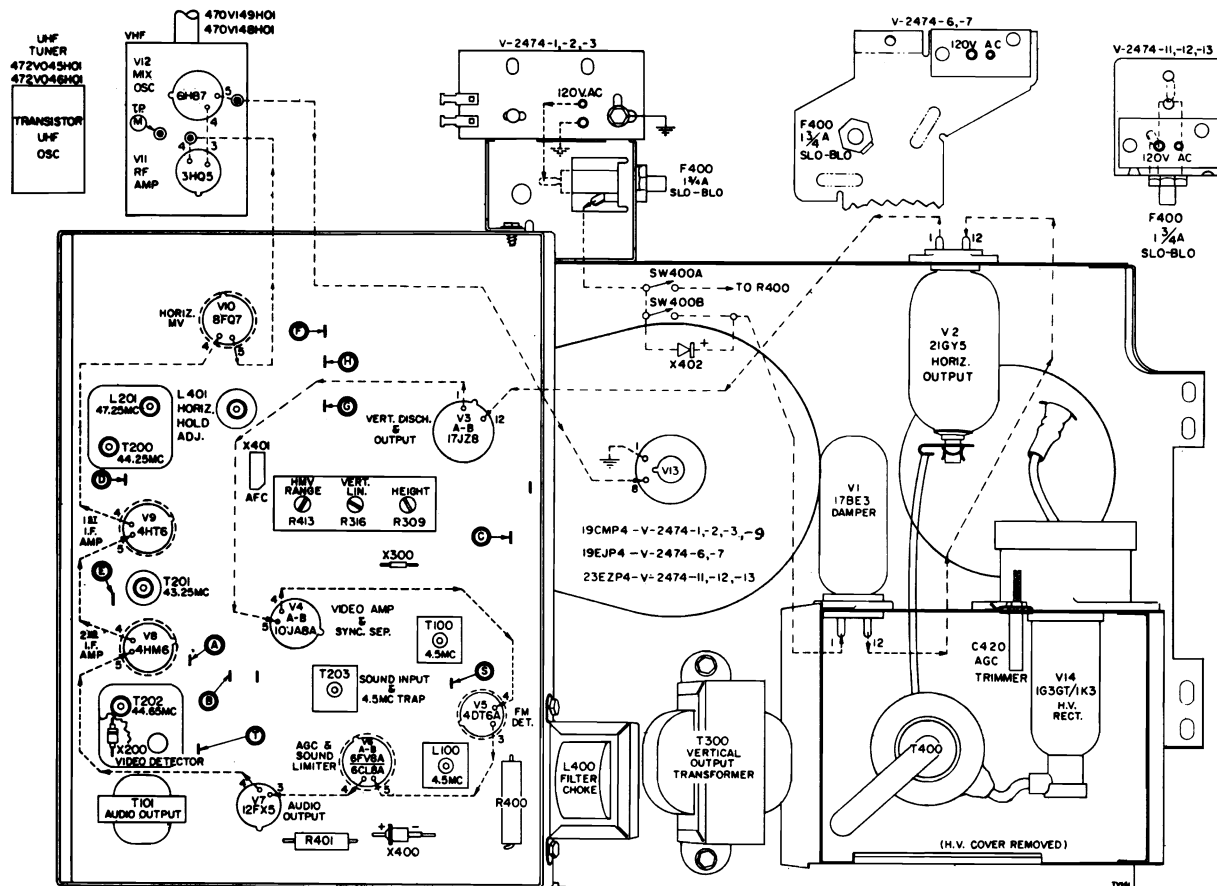

Figure 10. Rear View For Adjustments.

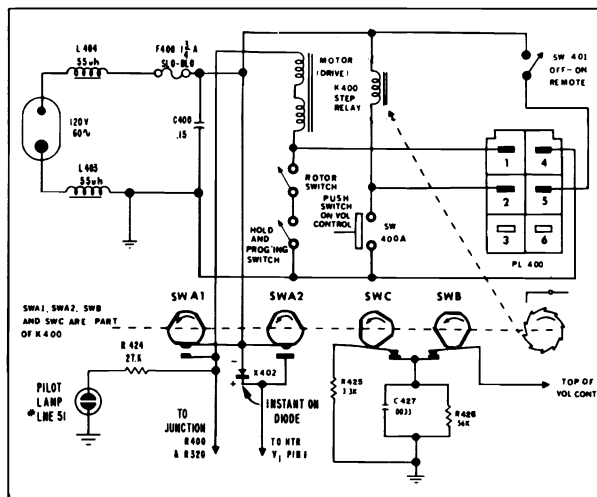

Figure 9. V-2474-3 AC input circuit, showing stepping relay.

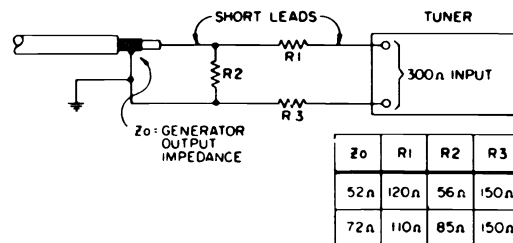

Figure 11 - Impedance Matching Network.

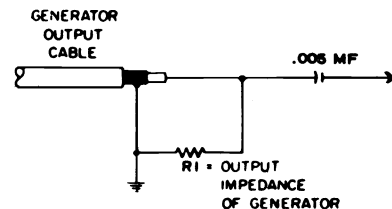

Figure 12 - Generator Cable Termination.

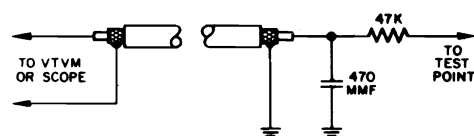

Figure 13 - VHF Decoupling Network.

VOLUME TV-24, ADDITIONAL 1965 TELEVISION SERVICING INFORMATION

WESTINGHOUSE Chassis V-2474-1, -2, etc. Alignment Information, Continued

IF ALIGNMENT

| Step | Test Equipment and Connection | Adjustment |
|------|--|--|
| 1. | -3V bias to TP ④ and -2.0V bias to TP ⑤. Short antenna terminals. Channel selector to channel 10. Connect jumper from Pin 2 of V6B to B- to disable the AGC pulse. | |
| 2. | Oscilloscope and VTVM to TP ⑥. IF sweep generator with CW marker to TP ⑦. a. 44.65 MC. b. 45.75 MC. | a. T202 primary (top slug): Maximum amplitude on VTVM. T202 secondary (bottom slug): Rocking symmetrical response at 44.65 MC. b. Place 45.75 MC marker at 70% of peak response (see Figure 14) for waveshape and marker placement. |
| 3. | CW generator to TP ⑧. a. 43.25 MC. | a. T201: Maximum amplitude on VTVM. |
| 4. | CW generator to TP ⑨. a. 44.25 MC. b. 44.25 MC. c. 47.25 MC. It may be necessary to increase generator output and/or decrease bias. | a. Tuner mixer output coil: Maximum on VTVM. b. T200: Maximum on VTVM. c. L201: Minimum on VTVM. |
| 5. | Connect sweep generator to TP ⑩ at 44.25 MC. Couple CW generator with marker at 44.25 MC to sweep generator cable. Keep marker amplitude low to avoid distorting response. Adjust scope for 2V PP. | Mixer output coil for maximum amplitude. T200 for "rocking symmetrical response with waveshape and markers" as shown in Figure 16. |
| 6. | CW generator to TP ⑩ at 47.25 MC. | Repeat step 4c. |
| 7. | Oscilloscope, 2V PP. Sweep generator thru impedance matching network (see Figure 11) to antenna terminals. Set pix marker at 211.25 MC, channel 13. Inject 45.75 MC marker into IF section by connecting CW output cable to outer shield of IF link cable. | Fine tuning to center of range. Channel selector to channel 13. Oscillator slug setting: Picture carrier should fall at 45.75 MC (\pm 300 KC) marker on scope. (See Figure 17). |
| 8. | Repeat step 7 for all channels in descending order. | |

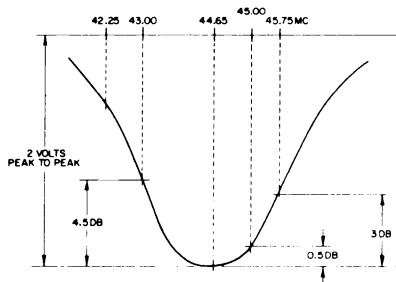

Figure 14 - Typical IF Response, 2nd IF Amp Grid to 2nd Det.

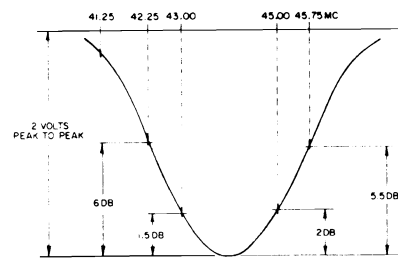

Figure 15 - Typical IF response, 1st IF Amp Grid to 2nd Det.

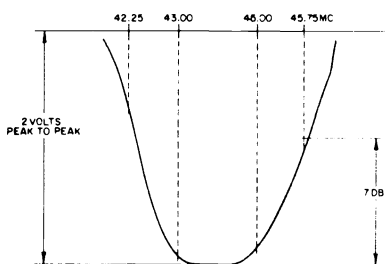

Figure 16 - Typical IF response, Mixer Amp grid to 2nd Det.

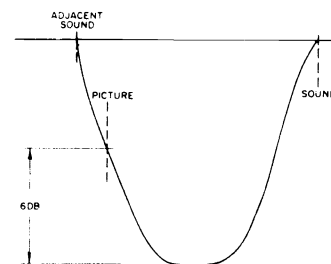

Figure 17 - Typical RF-IF response.

Westinghouse

MODEL AND CHASSIS CHART

| MODEL | CHASSIS | TUNERS | FEATURES | CRT |
|---|-----------|--------------------------------------|---|----------------|
| H-P3040 H-P3041 | V-2475-1 | 470V149H01 (VHF) 472V045H01 (UHF) | INSTANT ON | 19CMP4 114° |
| H-P3255 H-P3256 | V-2475-4 | 470V149H01 (VHF) 472V045H01 (UHF) | INSTANT ON STEEL-GUARD CRT | 19EJP4 114° |
| H-K4080 H-K4081 H-K4083 H-K4182 H-K4183 | V-2475-12 | 470V152H01 (VHF) 472V046H01 (UHF) | INSTANT ON STEEL-GUARD CRT ILLUMINATED DIAL | 23EJP4 94° |

CHASSIS REMOVAL

23" Models (Refer to Figure 3)

1. Remove the control knobs.
2. Remove the back cover.
3. Disconnect the wire between the control bracket and the CRT bracket.
4. Disconnect the high-voltage wire, cap, and dag spring from the CRT.
5. Loosen the yoke clamp.
6. Disconnect the speaker wires at the audio output transformer.
7. Remove the screws numbered 1 through 13 in Figure 3. Two studs on the side of the tuner mounting panel can be hooked into slots in the side bracket of the PC board for ease in handling and servicing.

8. Remove the yoke from the CRT and carefully remove the chassis.

19" Models with V-2475-4 Chassis (Refer to Figure 2)

1. Remove all control knobs except the VHF fine tuning knob. (The fine tuning knob is captivated to the tuner and pulls out with the chassis.)
2. Remove the back cover.
3. Disconnect the speaker wires at the audio output transformer.
4. Disconnect the CRT cap and high voltage wire, and loosen the yoke clamp.
5. Remove the screws numbered 1 through 11 in Figure 2.
6. Remove the yoke from the CRT and carefully remove the chassis.

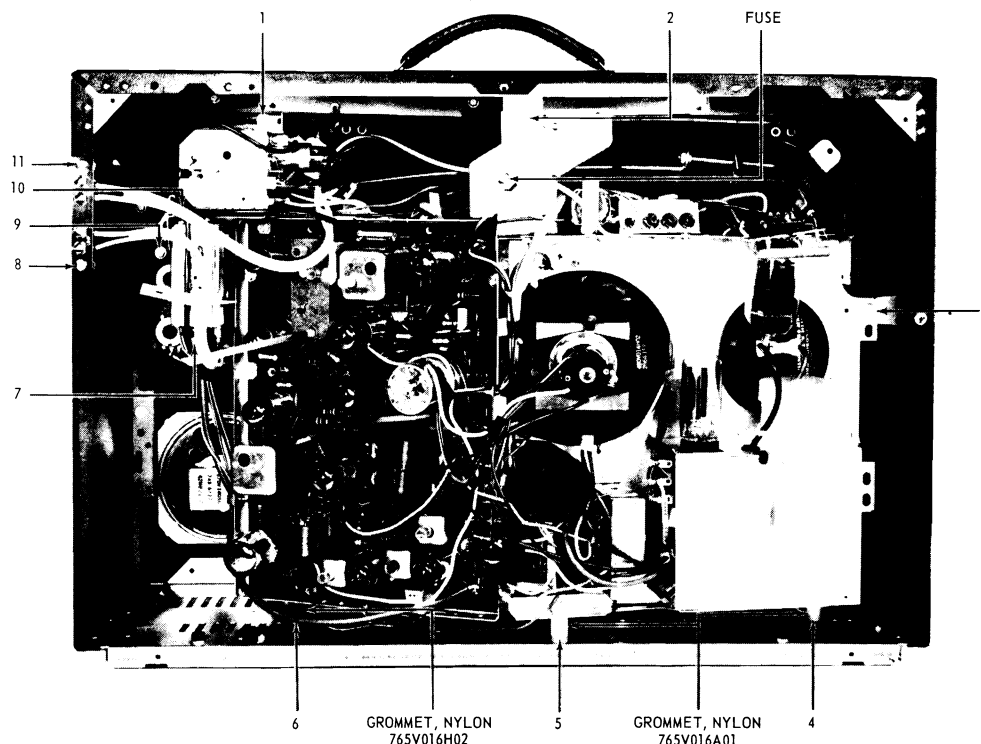

Figure 2 – Rear view of 19" chassis, showing location of screws for chassis removal.

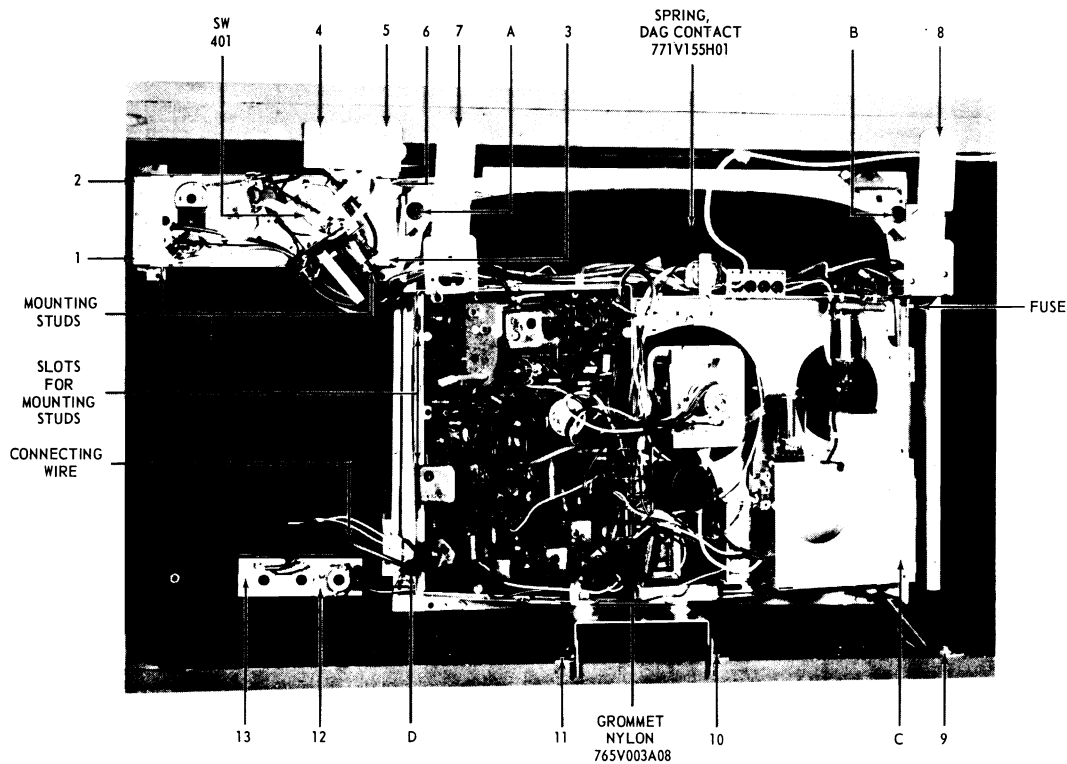

Figure 3 - Rear view of V-2475-12 chassis, showing location of screws for chassis removal.

19" Models with V-2475-1 Chassis

1. Remove all control knobs except the Vertical and Brightness thumbwheels and the VHF fine tuning knob. (The thumbwheels are removed with the control bracket from the rear of the cabinet. The fine tuning knob is captivated to the tuner and pulls out with the chassis.)
2. Disconnect the antenna leads.
3. Remove the back cover.
4. Remove the mounting screw at each of the following locations:

| | |
|------------------------|----------------------------|
| a. Control bracket | d. Top center of chassis |
| b. Top of VHF tuner | e. Right center of chassis |
| c. Bottom of UHF tuner | |
5. Disconnect the speaker leads at the audio output transformer.
6. Disconnect the CRT cap and high-voltage wire, and loosen the yoke clamp.
7. Carefully remove the chassis with the yoke, tuner, and control bracket.

CRT REMOVAL

23" Models

1. Remove the chassis.
2. Lay the cabinet face down on a soft cloth.
3. Remove the four CRT retaining screws (A, B, C, and D in Figure 3) and carefully remove the CRT. The strap around the CRT and the four mounting ears are part of the 23EZP4 CRT and cannot be removed.
4. Disconnect the dag spring from the chassis.

19" Models with V-2475-1 Chassis

1. Remove the chassis.
2. Lay the cabinet face down on a soft cloth.
3. Loosen the screw that holds the wire retaining ring around the CRT.
4. Unhook the four corner retainers from the cabinet.
5. Remove the retaining ring with the four corner retainers.

PC BOARD ACCESSIBILITY

To provide access to the underside of the PC board while the set is operating:

1. Remove the chassis.
2. Turn the chassis around.
3. Connect the CRT socket, yoke, and high-voltage lead (use a jumper). A test speaker may be connected to the audio output transformer.

WARNING: To operate the set partially disassembled, connect a jumper from the aquadag CRT coating to chassis ground. Be careful that the high-voltage anode lead does not short or arc to the frame.

When servicing sets that have a Steel-Guard CRT, connect a jumper from the metal cabinet to chassis ground.

CENTERING

The centering rings, located at the rear of the deflection yoke, should be rotated to center the raster.

DEFLECTION YOKE

The deflection yoke should be as far forward as possible (touching the bell of the CRT). Rotation of the deflection yoke is used to level the raster.

WIDTH AND HEIGHT

The Width and Height controls are part of the Quadruple Control Assembly, located at the top right of the chassis.

AGC LEVEL CONTROL

This adjustment is factory set. Normally, no adjustment will be needed in the field.

Should adjustment be necessary, select the channel with the strongest signal. Turn the control (part of the Quadruple Control Assembly) clockwise until a slight bend appears at the top of the picture. Then turn the control slowly counter-clockwise about 1/4 turn past the point at which the bend disappears.

TV-24, ADDITIONAL 1965 TELEVISION SERVICING INFORMATION

WESTINGHOUSE Chassis V-2475-1, -4, -12
Service Information, Continued

Figure 7 - Bottom view of video detector PC board.

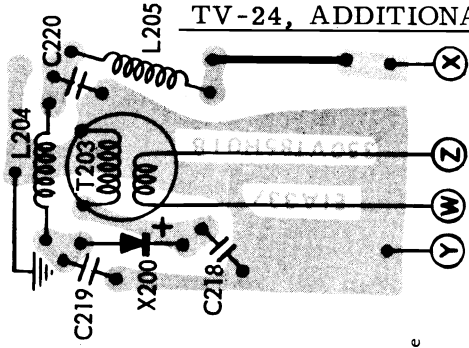

TEST POINTS

- A. AGC for IF
- B. Video detector
- C. CRT cathode
- D. 1st IF grid
- E. 3rd IF grid
- F. Horiz MV
- G. Horiz Hold adjust coil
- H. Horiz Hold adjust coil
- S. Quad coil
- T. AGC for tuner

PC BOARD LEGEND

1. Volume control, low side
2. V1 pin 2, and R415
3. Tuner filament
4. IF input
5. CRT pin 8
6. Tuner filament
7. Tuner AGC
8. (V-2475-1, -4) Junction C423, C424
9. (V-2475-11, -12, -13) Z401 pin 3
10. Height control, high side
11. Vertical Linearity control, high side
- 11A. Vertical Hold control, high side
12. T300, blue wire
13. Contrast control, high side
14. Volume control, high side
15. Contrast control, arm
16. Brightness control, arm
17. CRT pin 3
18. T401 lug 1
19. Junction T300 secondary, C311
20. CRT pin 2
21. Brightness control, high side
22. CRT pin 7
23. Tuner B+ terminal board, to R201
24. Contrast control, low side
25. AGC Level control (R304A), high side
26. CRT pins 1 and 4 (two wires)
27. Horizontal Range control (R410A), high side
28. V2 pin 12
29. T101, blue wire
30. T101, red wire
31. Junction R402 and C406A
32. Volume control, arm

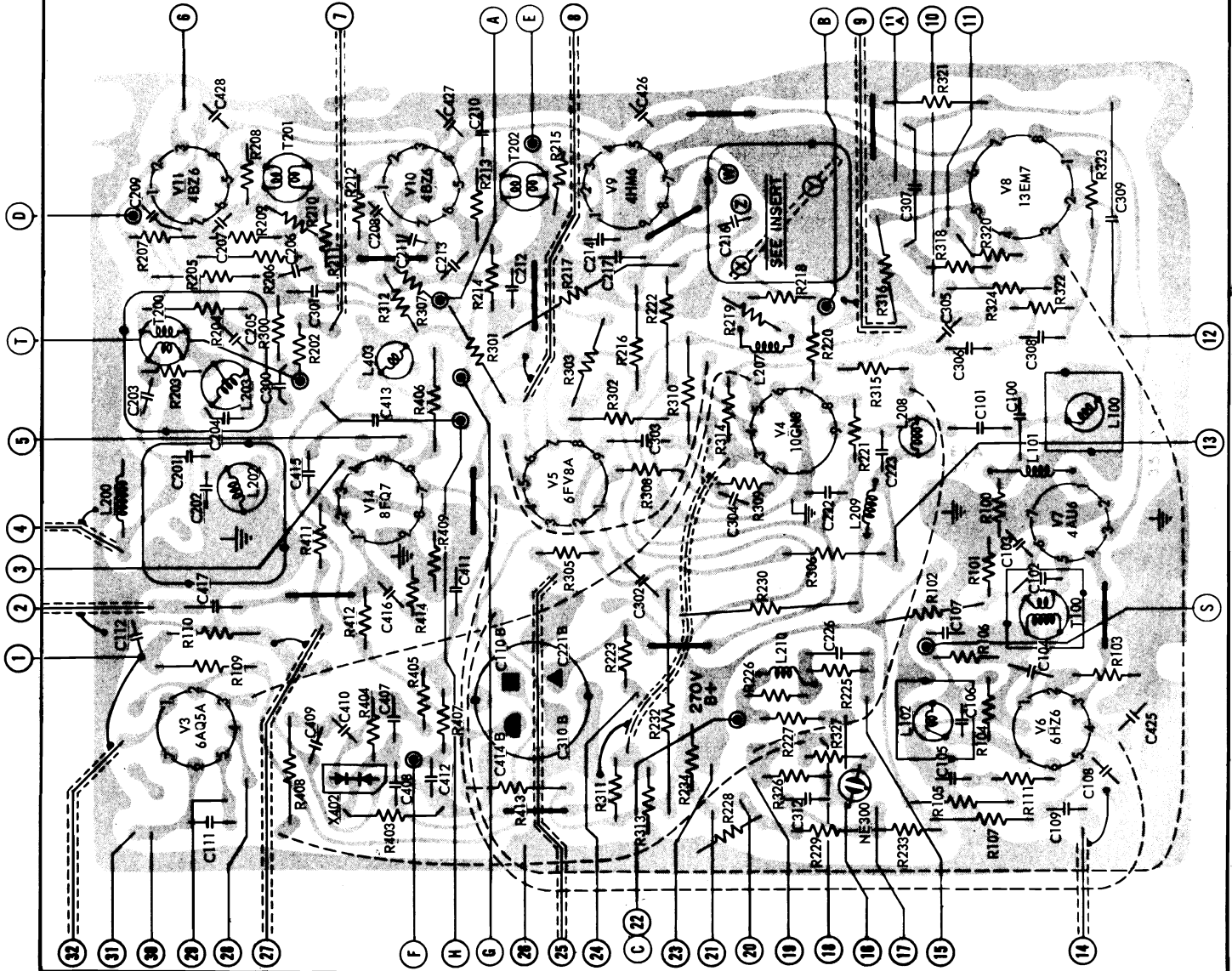

Figure 6 - Bottom view of PC board, showing top components in solid outline. Tube pin numbering is for bottom of socket.

VOLUME TV-24, ADDITIONAL 1965 TELEVISION SERVICING INFORMATION

WESTINGHOUSE Chassis V-2475-12 Schematic Diagram

(Note: Chassis V-2475-1, -4, use 19" picture tube for V15, and are practically identical otherwise)

NOTES:

1. ALL CAPACITANCE VALUES LESS THAN 1 ARE IN MF AND VALUES GREATER THAN 1 ARE IN PF WHILE ALL RESISTANCE VALUES ARE IN OHMS, 1/2 WATT UNLESS OTHERWISE INDICATED
2. D.C. VOLTAGES MEASURED FROM B-WITH A VTVM, NO SIGNAL APPLIED, LINE VOLTAGE AT 120 VAC *
3. WAVEFORMS WERE TAKEN WITH CONTROLS SET FOR NORMAL PICTURE
4. MAKES CONTACT ON CHAN *1
5. CIRCLED NUMBERS REFER TO WAVE FORMS.

* PART OF QUADRUPLE CONTROL ASSY.

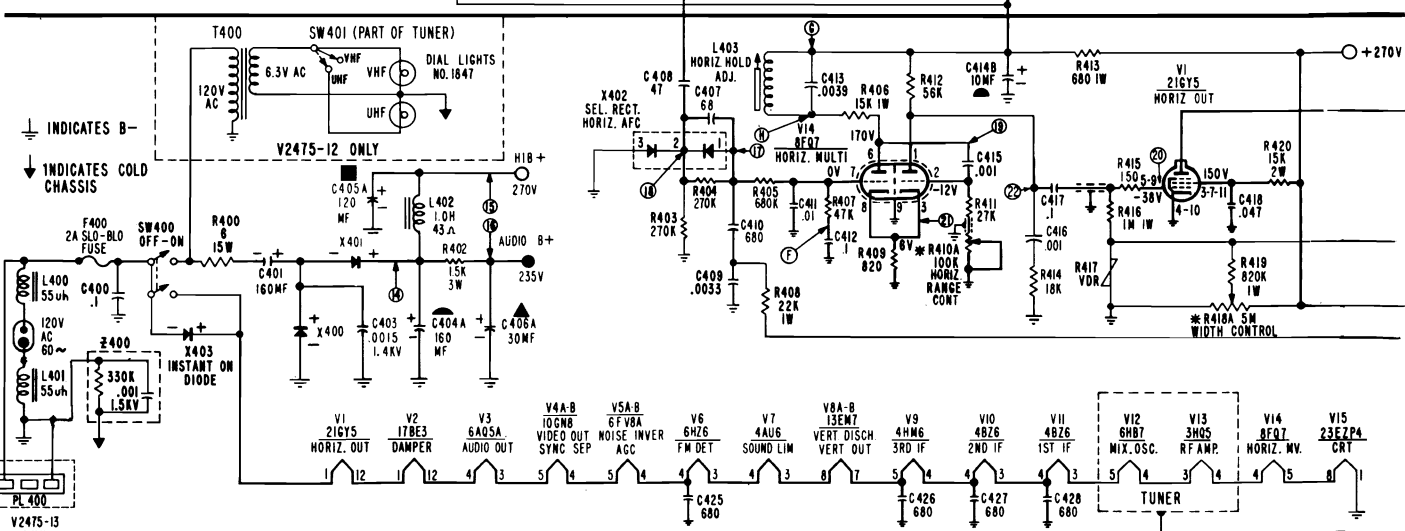
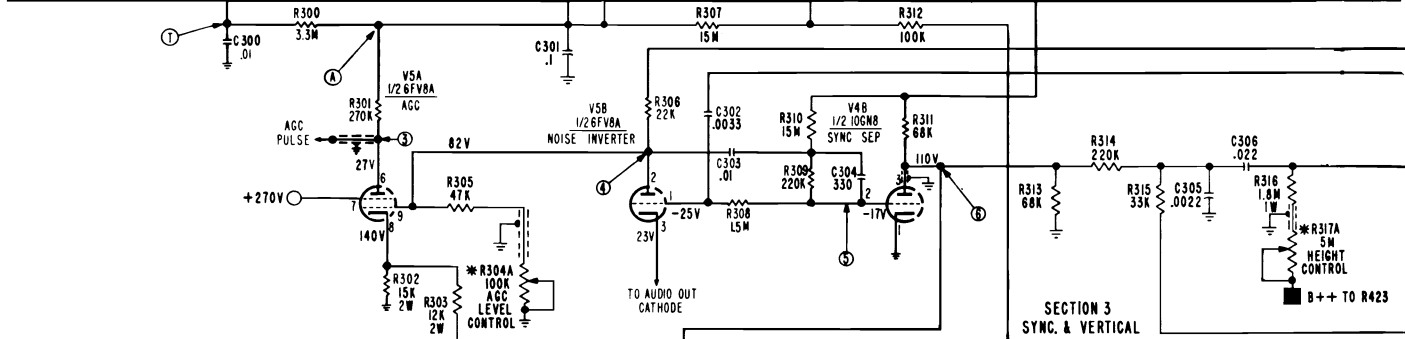
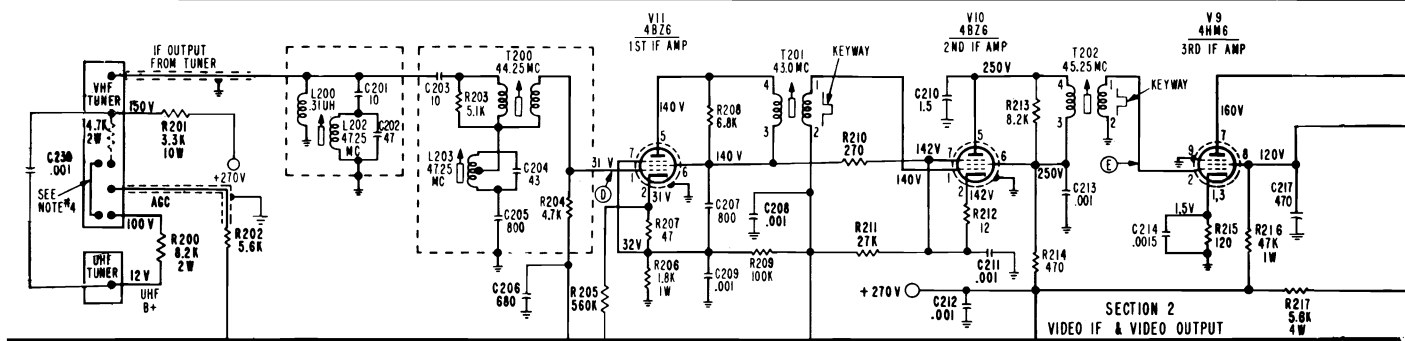
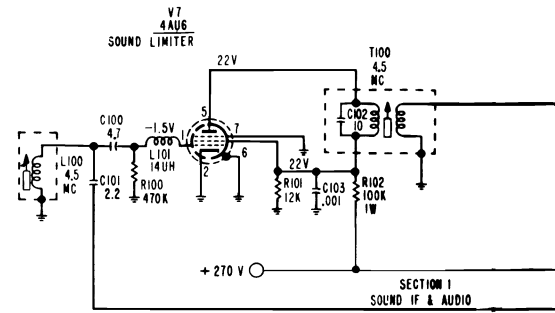

⊕ INDICATES B-
↓ INDICATES COLD CHASSIS

V2475-13 ONLY

SECTION 4
HORIZ & POWER

VOLUME TV-24, ADDITIONAL 1965 TELEVISION SERVICING INFORMATION

WESTINGHOUSE Chassis V-2475-12 Schematic Diagram, Continued

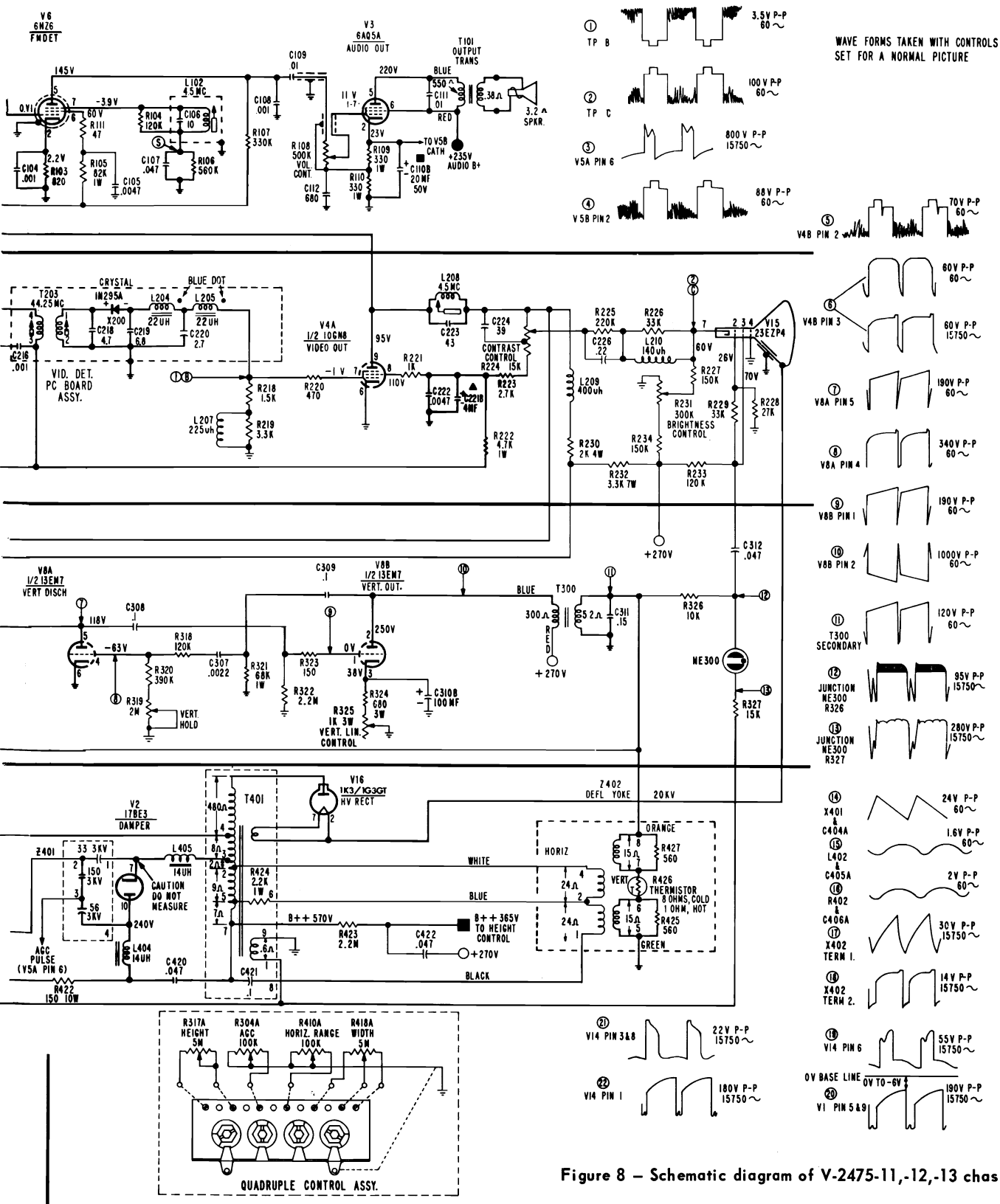

Figure 8 - Schematic diagram of V-2475-11, -12, -13 chassis.

VOLUME TV-24, ADDITIONAL 1965 TELEVISION SERVICING INFORMATION

WESTINGHOUSE Chassis V-2475-1, -4, -12, Service Information, Continued

TUBE COMPLEMENT AND RESISTANCE CHART

| TUBE | TYPE | FUNCTION | Pin 1 | Pin 2 | Pin 3 | Pin 4 | Pin 5 | Pin 6 | Pin 7 | Pin 8 | Pin 9 | Pin 10 | Pin 11 | Pin 12 |
|------|------------------|----------------------------|----------|-------|-------|-------|-------------|-------------|-------|-------|-------|--------|--------|--------|
| V1 | 21GY5 | Horiz. out. | 40 | 2.4M | *15K | 0 | 2.4M | 47 | *15K | NC | 2.4M | 0 | *15K | 33 |
| V2 | 17BE3 | Damper | 33 | NC | *197 | NC | NC | NC | Inf. | NC | NC | *197 | NC | 28 |
| V3 | 6AQ5A | Audio Out. | 300K | 660 | 27 | 28 | *2K | *1.5K | 300K | | | | | |
| V4 | 10GN8 | Video Out. Sync. Sep. | 0 | *15M | *38K | 23 | 27 | 0 | ●850 | *9K | *4.8K | | | |
| V5 | 6FV8A | Noise Inv., AGC | *17M | *25K | 660 | 21 | 23 | 830K | *47 | *10K | *25K | | | |
| V6 | 6HZ6 | FM Det. | 4 | 820 | 19 | 21 | *330K | *82K | 560K | | | | | |
| V7 | 4AU6 | Sound Lim. | 470K | 0 | 17 | 19 | *24K 12K | *24K 12K | 0 | | | | | |
| V8 | 13EM7 | Vert. Disch. Vert. Out. | 2.2M | *350 | 1.3K | 2M | - | 0 | 13 | 17 | | | | |
| V9 | 4HM6 | 3rd IF Amp. | 120 | .1 | 120 | 11 | 13 | .1 | *5.6K | *47K | 0 | | | |
| V10 | 4BZ6 | 2nd IF Amp. | *60K | *90K | 10 | 11 | *520 | *520 | *90K | | | | | |
| V11 | 4BZ6 | 1st IF Amp. | 567K | 1.5K | 9 | 10 | *90K | *90K | 1.5K | | | | | |
| V12 | 6HB7 | Mix.-Osc. | 0 | 220K | 0 | 7 | 9 | *4.3K | *25K | *8K | 3.3K | | | |
| V13 | 3HQ5 | RF Amp. | 4M | 0 | 7 | 5.5 | *4.5K | 0 | 0 | | | | | |
| V14 | 8FQ7 | Horiz. MV | *57K | 40K | 820 | 5.5 | 2 | *16K | 1.2M | 820 | 0 | | | |
| V15 | 23EZP4 | CRT | 0 | 27K | 40K | 0 | - | - | 120K | 2 | | | | |
| | 19CMP4 19EJP4 | CRT | 0 | 18K | 40K | 0 | - | - | 120K | 2 | | | | |
| V16 | 1K3/1G3GT | HV Rect. | INFINITE | | | | | | | | | | | |

Resistances measured from tube pin to circuit ground.

*Resistance measured from tube pin to junction of X401 & L402.

●R x 100 scale.

NC = No connection.

HORIZONTAL HOLD ADJUSTMENT COIL, L403

1. Connect a jumper between TP ⑥ and TP ⑩ to short out coil L403.
2. Calibrate a VTVM to 0V center scale on the 1.5V range. Connect the meter to measure DC voltage between TP ⑥ and circuit ground.
3. Tune the receiver to a station of normal signal strength. Adjust the Horizontal Range Control, R410A (part of the Quadruple Control Assembly, located at the top right of the chassis) to lock the picture into horizontal sync. Then adjust R410A for zero volts on the VTVM.
4. Remove the jumper across L403.
5. Tune L403 to lock the picture into horizontal sync. Adjust the core to the first position that will lock the picture into horizontal sync as the core is moved from the top of the coil form toward the PC board. Then adjust L403 for zero volts on the VTVM.

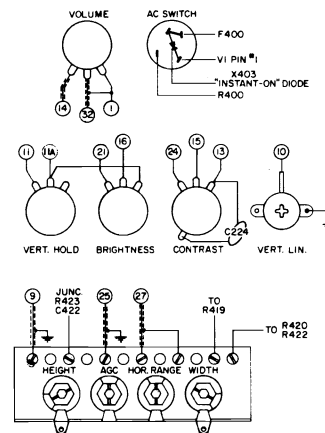

Figure 10 - Control wiring diagram.

All views seen from the rear.

SOUND ALIGNMENT

EQUIPMENT: VTVM

PROCEDURE:

1. Select the strongest station available (preferably with test pattern and test tone) and adjust the FINE TUNING for best reception. Adjust the VOLUME control so that the station sound is audible.
2. Adjust the quad coil (L102) for maximum sound from the speaker.
3. Disconnect the antenna. Use a jumper wire to short TP ⑤ to B-.
4. Connect the VTVM to TP ⑤.
5. Adjust interstage transformer T100 for maximum negative voltage on the VTVM.
6. Remove the jumper wire used to short TP ⑤ to B-.
7. Place the antenna input close to the antenna terminals so that the signal is loosely coupled to the receiver and the picture is barely visible. A pronounced noisiness (hiss) should accompany the sound.

8. Adjust the limiter input coil (L100) for maximum negative voltage on the VTVM. If the VTVM indicates a broad response while making this adjustment, the receiver input signal is too strong. When the signal coupling described in step 7 is at the necessary low point, no limiting takes place and the VTVM will indicate a sharp response to the limiter input coil adjustment.

4.5 MC TRAP ALIGNMENT

Disconnect the antenna and turn contrast control to maximum clockwise. Inject a 4.5 MC CW signal through a .001mf capacitor to TP ⑤. Connect a .001mf capacitor to a demodulation probe tip. Connect the other end of the probe to a VTVM and the capacitor to TP ⑥. Set the VTVM to 1.5-2V DC range. Turn the set on and allow ten minutes for warmup. Then adjust L208 for minimum on the VTVM.

VOLUME TV-24, ADDITIONAL 1965 TELEVISION SERVICING INFORMATION

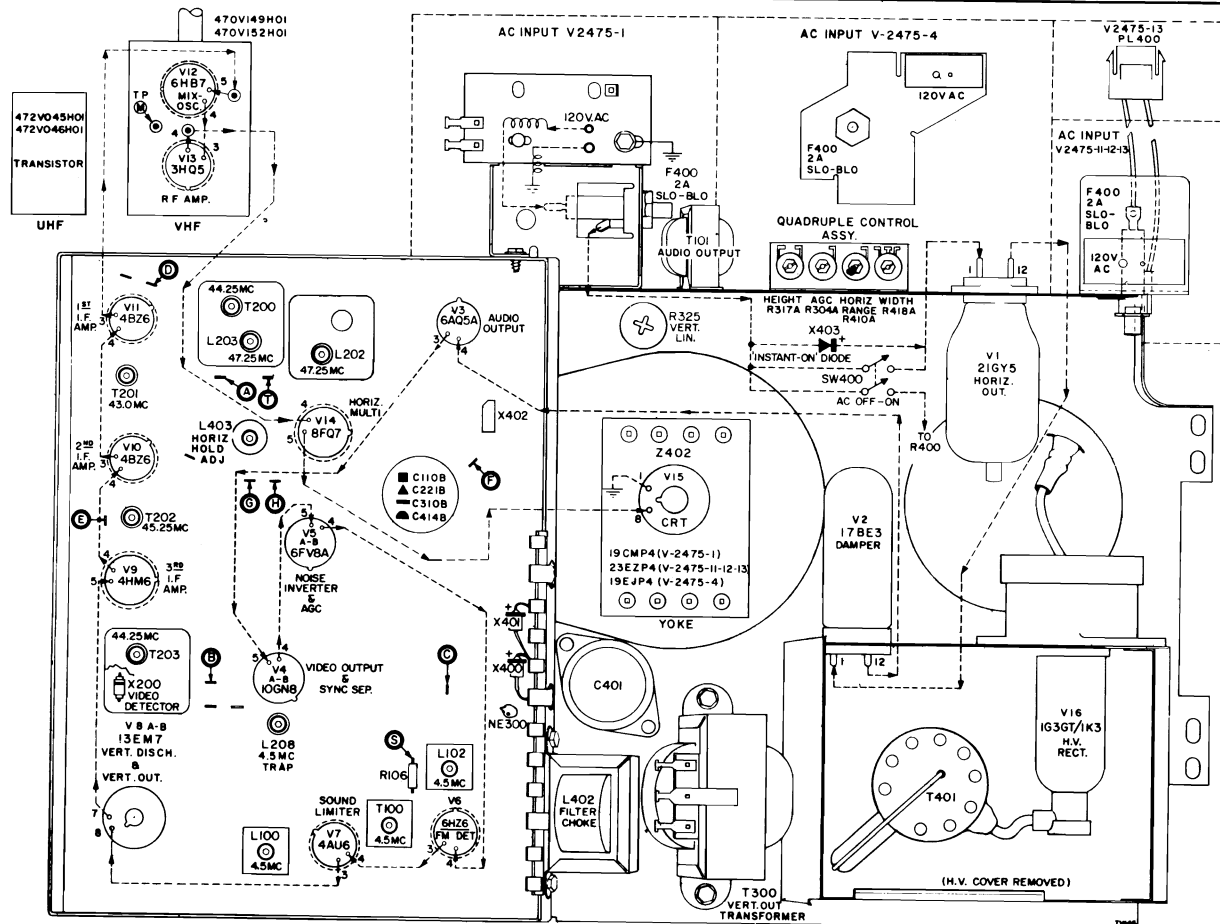

Figure 5 - Rear view of chassis.

IF ALIGNMENT

EQUIPMENT

1. Sweep Generator with a 10 MC wide sweep at center frequencies from 10 MC to 90 MC and 170 MC to 216 MC.
2. CW (Marker) Generator which accurately produces the IF and RF frequencies from 4.5 MC to 216 MC.
3. Oscilloscope with good low frequency response characteristics.
4. VTVM
5. Bias Supply of -2.5 volts.
6. Standard Alignment Tool with a 3/32" hexagonal tip. (long enough to reach bottom slugs)

TERMINATION AND ADJUSTMENT OF EQUIPMENT

Oscilloscope and VTVM - Use a low-capacitance direct probe terminated with the decoupling network shown in Figure 13. Keep the oscilloscope calibrated for 2 volts peak to peak (P-P). Use a VTVM range suitable for measuring -1.5 volts.

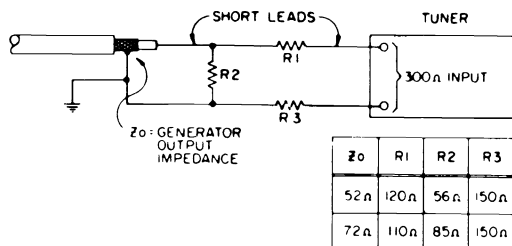

Figure 11 - Impedance Matching Network

Generators - Except where otherwise noted, all signal generating equipment should be terminated as shown in Figure 12. Connect the signal cable ground near the ground of the stage where the signal is injected. Adjust the CW generator output so that: (1) When the VTVM is being used its reading remains near the -1 volt point. (2) When the oscilloscope is being used the marker frequencies do not distort the response curve.

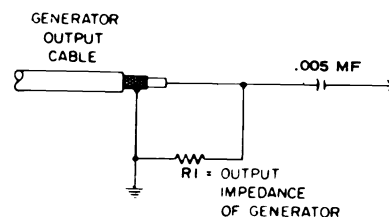

Figure 12 - Generator Cable Termination

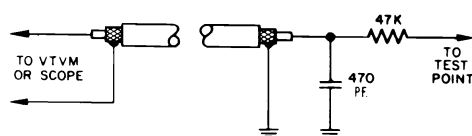

Figure 13 - Decoupling Network

VOLUME TV-24, ADDITIONAL 1965 TELEVISION SERVICING INFORMATION

WESTINGHOUSE Chassis V-2475-1, -4, -12, Alignment, Continued

ALLOW A TEN-MINUTE WARMUP BEFORE BEGINNING ALIGNMENT.

| STEP | TEST EQUIPMENT AND CONNECTION | ADJUSTMENT |
|------|--|--|
| 1. | Jumper from B- to TP (A), -2.5v to TP (T) | Channel selector to channel 10 |
| 2. | Oscilloscope and VTVM to TP (B) IF sweep generator with CW Marker at 44.25 MC to TP (E) | Short antenna terminals. T203 primary (bottom slug): Maximum amplitude T203 secondary (top slug): Rocking symmetrical response (see Figure 14) |
| 3. | CW generator to TP (D) at: a. 45.25 MC b. 43.00 MC | T202: Maximum amplitude T201: Maximum amplitude |
| 4. | IF sweep generator at 44.25 MC to TP (D). Couple CW marker generator to sweep generator cable. Keep marker amplitude at minimum to avoid distorting response. | T201, T202, T203: Slight retouching may be necessary to obtain response curve with correctly placed markers as shown in Figure 15. Use T203 (top slug) to flatten peak of curve, T201 to adjust low frequency slope and T202 to adjust high frequency slope. |
| 5. | CW generator to TP (M) (see Figure 20): a. 44.25 MC b. 44.25 MC c. 47.25 MC It may be necessary to increase generator d. 47.25 MC output and/or remove the ground from TP (A). | Tuner mixer output coil: Maximum on VTVM T200: Maximum on VTVM L202: Minimum on VTVM L203: Minimum on VTVM |
| 6. | Connect IF sweep generator to TP (M) at 44.25 MC. Couple CW generator with marker at 44.25 MC to IF sweep generator cable. Keep marker amplitude low to avoid distorting response. Adjust scope for 2V-PP. | Adjust mixer output coil and T200 for a "rocking" symmetrical response at approximately 44.25 MC with maximum amplitude and markers as shown in Figure 16. |
| 7. | CW generator to TP (M) at 47.25 MC. | L203: Minimum amplitude (see Step 5d). |
| 8. | IF sweep generator to TP (M) at 44.25 MC. | Wave shape as shown in Figure 16. |
| 9. | Oscilloscope, 2V-PP. RF sweep generator thru impedance matching network (See Figure 11) to antenna terminals. Set pix marker at 193.25 MC Channel 10. Inject 45.75 MC marker into IF section by connecting CW output cable to outer shield of IF link cable. | Fine tuning screws to approximate center of range. Channel selector to Channel 10. If necessary, adjust oscillator trimmer C18 to bring channels in range with F.T. screws at approximate center of range. Oscillator slug setting: Picture carrier should fall at 45.75 MC (± 300 KC) marker on scope. (See Figure 17). |
| 10. | Repeat step 9 for all channels using corresponding channel markers. | |

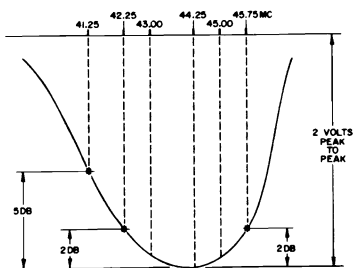

Figure 14 - Typical IF response, 3rd IF Amp grid to 2nd Det.

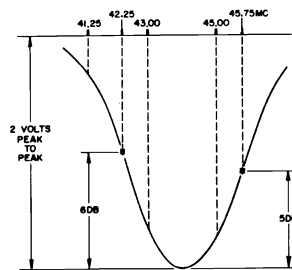

Figure 15 - Typical IF response, 1st IF Amp grid to 2nd Det.

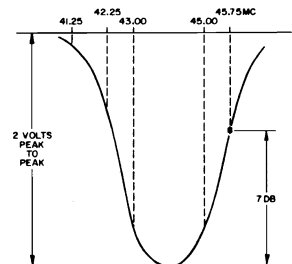

Figure 16 - Typical IF response, Mixer Amp grid to 2nd Det.

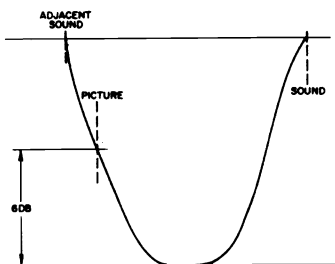

Figure 17 - Typical RF-IF response.

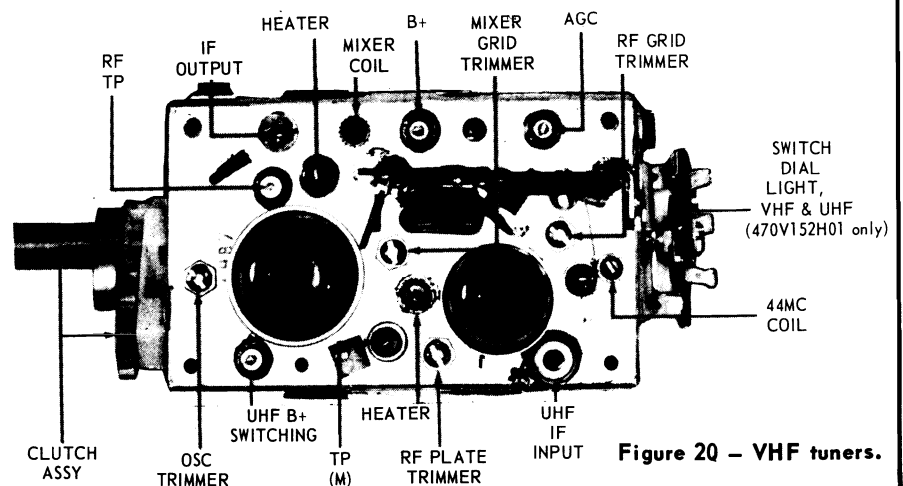

Figure 20 - VHF tuners.

Westinghouse

MODEL AND CHASSIS CHART

| MODEL | CHASSIS | TUNER | TUNER TUBES | FEATURES |
|--------------------|----------|----------------------------------|---|---|
| H-P8000 H-P8001 | V-2478-1 | 470V154H01 VHF 472V048H01 UHF | RF AMP - 3GK5 OSC-MIX - 6CG8A OSC - 3DZ4 OR 3AF4A/B XTAL - 1N82A | UNIPOLE ANTENNA |
| H-P8020 H-P8021 | V-2478-2 | 470V154H01 VHF 472V048H01 UHF | RF AMP - 3GK5 OSC-MIX - 6CG8A OSC - 3DZ4 OR 3AF4A/B XTAL - 1N82A | DIPOLE ANTENNA INSTANT ON EARPIECE JACK |

MECHANICAL INFORMATION

CHASSIS REMOVAL

1. Disconnect the spade lugs from the antenna terminals.
2. Remove the four (4) phillips-head screws that retain the back cover: two on the bottom, and one at the top of each side.
3. Remove the On-Off-Volume knob and the VHF and UHF tuner knobs.
4. Remove the seven (7) phillips-head screws around the edge of the PC board.
5. Disconnect the grounding cable from the high-voltage cage and the CRT strap.
6. Remove the tie wire from the yoke wires.
7. Unplug the CRT socket and anode connector from the CRT.
8. Loosen the yoke clamp, and slide the yoke slightly to the rear.
9. Remove the two (2) phillips-head screws that hold the vertical-output transformer to the cabinet.
10. Remove (unsolder) the two output-transformer leads from the PC board.

11. Remove the four (4) phillips-head screws that hold the tuner assembly to the front of the cabinet.
12. Slide the PC board and tuner assembly slightly to the rear, and remove the two (2) phillips-head screws that hold the control-mounting assembly to the front of the cabinet.
13. Position the chassis as shown in Figure 1.

FUSE

Fuse protection is provided by fusible resistor R501, located at the rear of the chassis (see Figure 2). The part number of this 5-ohm 7-watt resistor is 251V036H01.

PICTURE TUBE REMOVAL

- Use only an original-type CRT for replacement.
1. Remove the chassis (see chassis removal instructions).
 2. Remove the socket and the yoke from the CRT.
 3. Loosen the nut on the wire ring around the CRT, and remove the ring from the four corner retainers.
 4. Remove the picture tube.

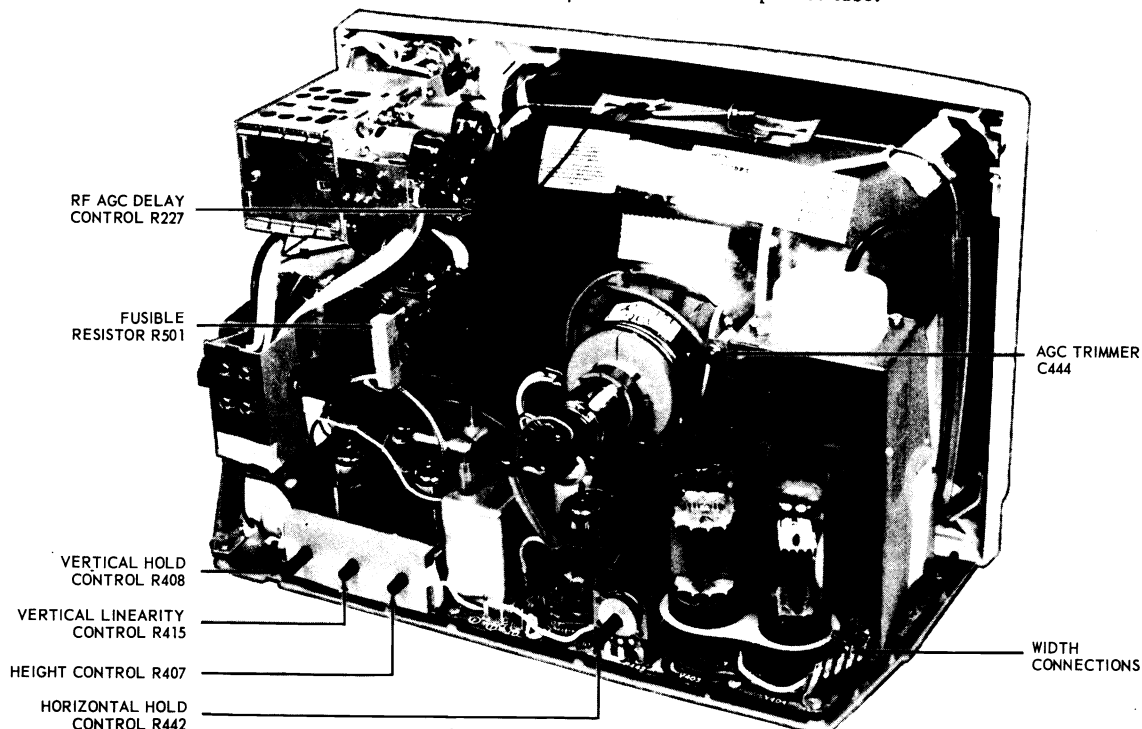

Figure 2 - Adjustments.

VOLUME TV-24, ADDITIONAL 1965 TELEVISION SERVICING INFORMATION

WESTINGHOUSE Chassis V-2478-1, -2, Schematic Diagram, Figure 4.

NOTES:

- ALL CAPACITOR VALUES LESS THAN 1.0 ARE IN PF. AND VALUES GREATER THAN 1.0 ARE IN PF. (PICOFARADS), ALL RESISTANCE VALUES ARE IN OHMS 1/2 WATT, UNLESS OTHERWISE INDICATED.
- DC VOLTAGES ARE MEASURED FROM POINT INDICATED TO CIRCUIT GROUND WITH A VTVM. LINE VOLTAGE AT 120 V.AC NO SIGNAL APPLIED.
- WAVEFORMS WERE TAKEN WITH CONTROLS SET FOR A NORMAL PICTURE.
- SWITCH MAKES CONTACT ON UHF POSITION ONLY.
- * RELOCATED OFF THE PC BOARD.
- ** JUMPER REMOVED IN LATE PRODUCTION

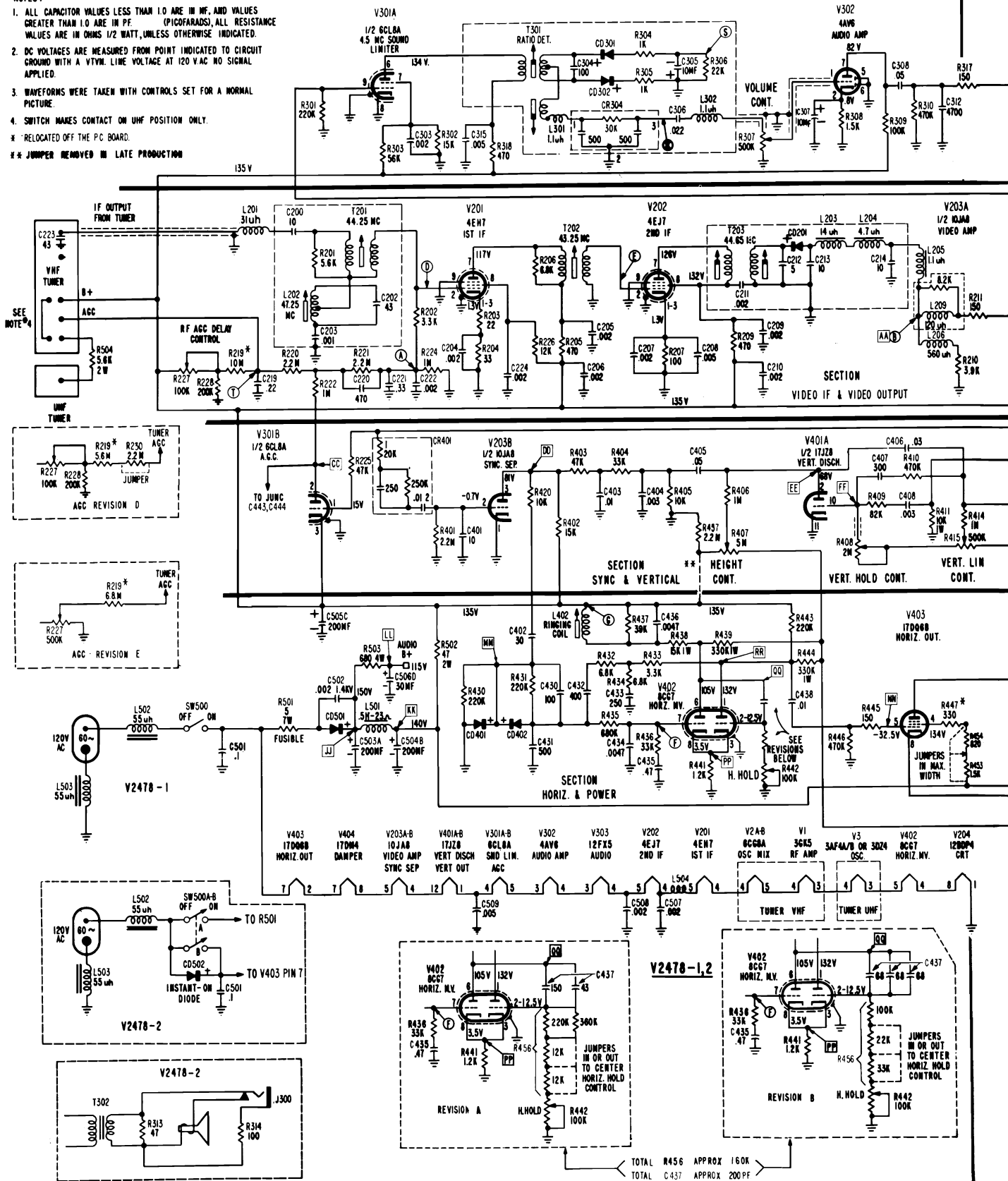

VOLUME TV-24, ADDITIONAL 1965 TELEVISION SERVICING INFORMATION

WESTINGHOUSE Chassis V-2478-1, -2, Schematic Diagram, Continued

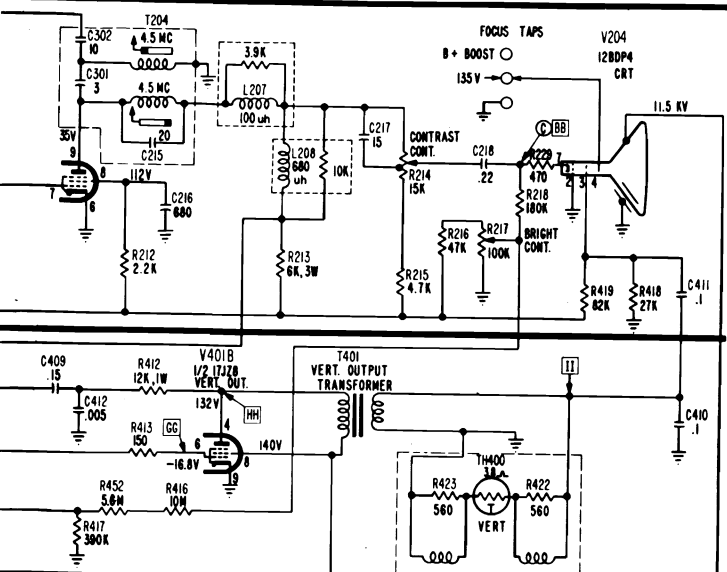
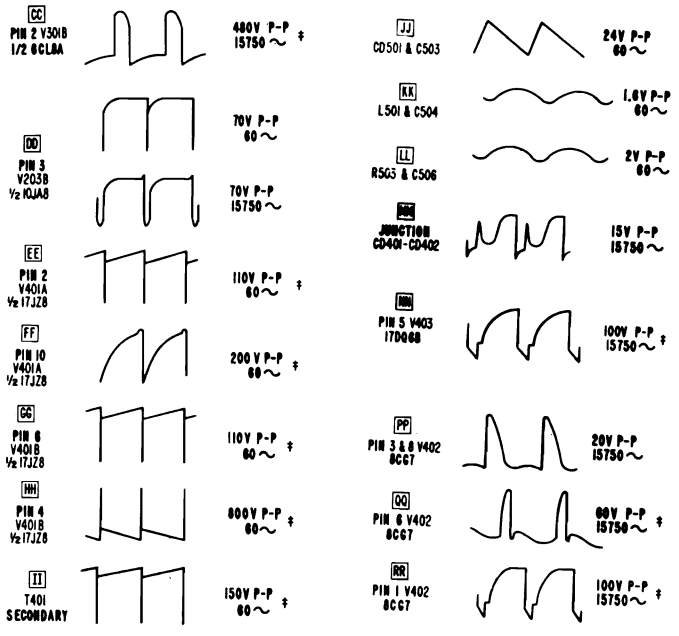
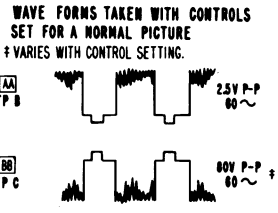
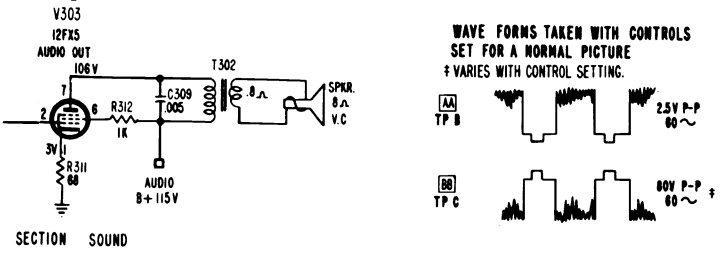

WIDTH ADJUSTMENT

To obtain maximum width, solder a jumper across resistors R453 and R454. The locations of these resistors are shown in Figure 5.

HEIGHT AND VERTICAL LINEARITY

The Height and Vertical Linearity controls, located at the rear of the chassis, are adjusted alternately for correct picture height and linearity.

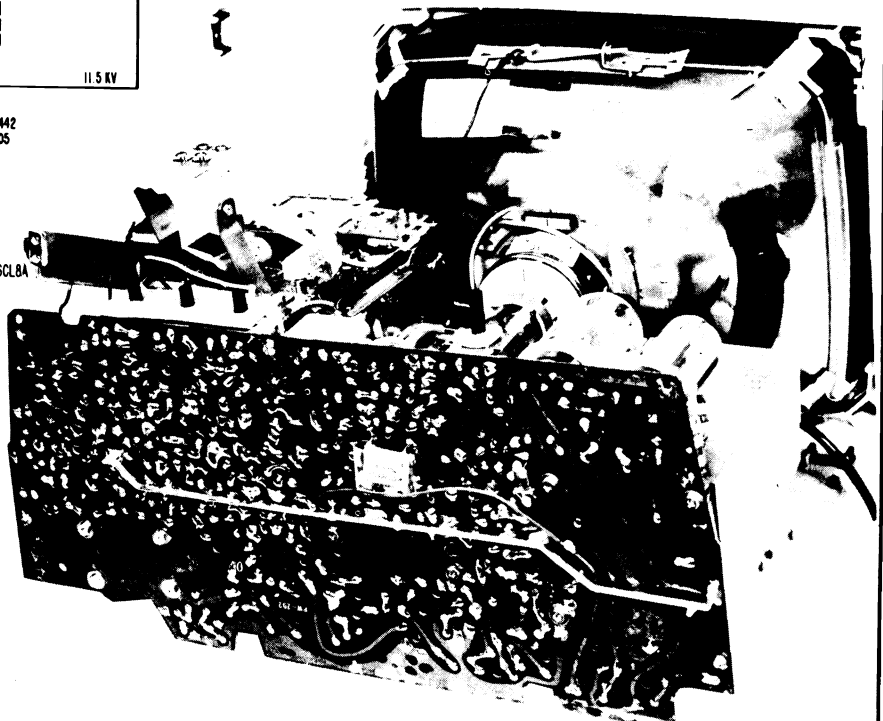
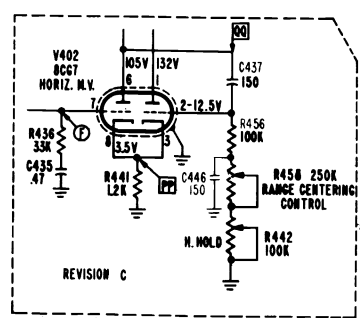
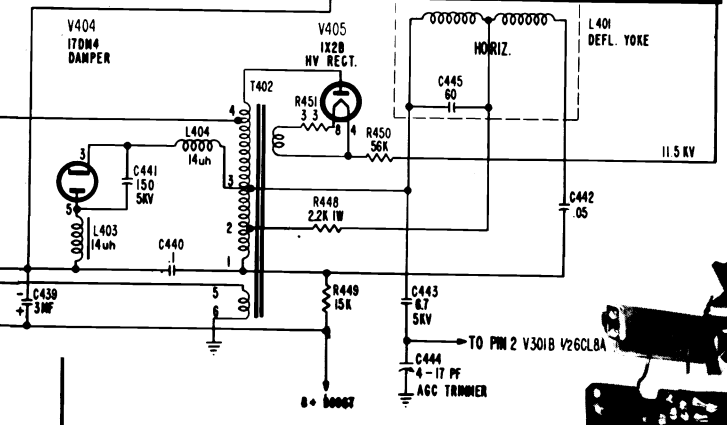

Figure 1 - Chassis Position For Servicing.

VOLUME TV-24, ADDITIONAL 1965 TELEVISION SERVICING INFORMATION

WESTINGHOUSE Chassis V-2478-1, -2

ADJUSTMENTS

CENTERING

The centering rings, located at the rear of the deflection yoke, should be rotated to center the raster.

DEFLECTION YOKE

The deflection yoke should be as far forward as possible (touching the bell of the CRT). Rotate the deflection yoke to level the raster.

HORIZONTAL FREQUENCY AND RINGING COIL (Chassis Without Range Centering Control R455)

1. Turn on the receiver, and set the fine tuning, brightness, and contrast controls for normal picture.
2. Connect a jumper across ringing coil L402.
3. Connect a VTVM, set to d-c center-zero scale, to TP @ (see Figure 4) and chassis ground.
4. Adjust Horizontal Hold control R442 (rear of chassis) for zero reading on meter scale. If control R442 is not close to the center of its mechanical range, reconnect jumpers as indicated in late production revisions to the schematic diagram (see Figure 4).
5. Remove the jumper across the ringing coil. If necessary, readjust the Horizontal Hold control to lock in the picture.
6. Adjust the ringing coil for a zero reading on the meter.

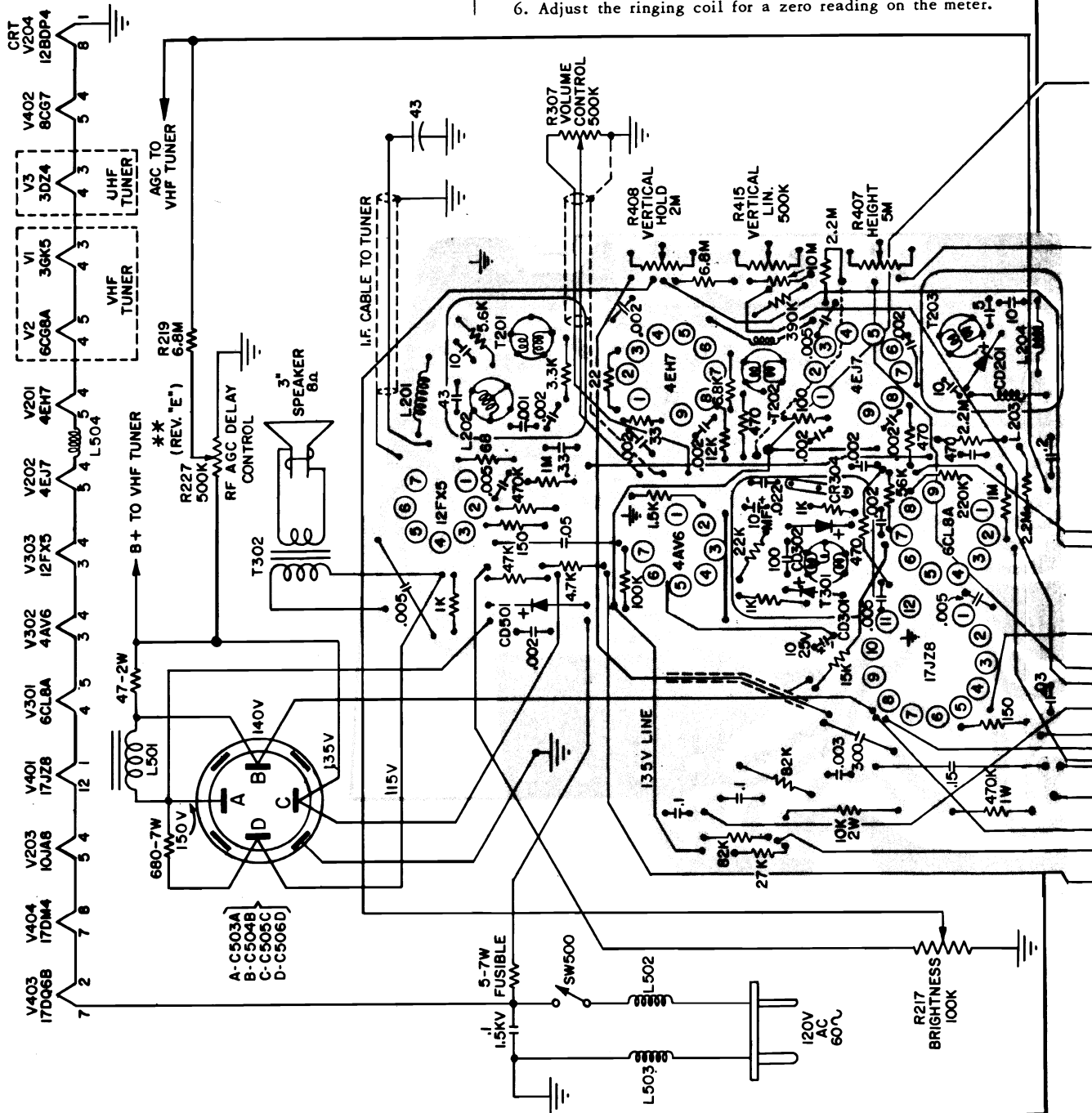

VOLUME TV-24, ADDITIONAL 1965 TELEVISION SERVICING INFORMATION

WESTINGHOUSE Chassis V-2478-1, -2, Service Information, Continued

TUBE COMPLEMENT AND RESISTANCE CHART

| NO. | TUBE TYPE | FUNCTION | RESISTANCE MEASUREMENTS | | | | | | | | | | | |
|------|-----------|----------------------|-------------------------|-------|-------|-------|-------|-------|-------|-------|-------|--------|--------|--------|
| | | | PIN 1 | PIN 2 | PIN 3 | PIN 4 | PIN 5 | PIN 6 | PIN 7 | PIN 8 | PIN 9 | PIN 10 | PIN 11 | PIN 12 |
| V403 | 17DQ6B | HORIZ. OUTPUT | | 34 | | *1.4K | 500K | | 40 | .6 | | | | |
| V404 | 17DM4 | DAMPER | | | 260K | | *20 | | 34 | 30 | | | | |
| V203 | 10JA8 | VIDEO AMP & SYNC SEP | 0 | 2.6M | *15K | 26 | 30 | 0 | 420 | *2.2K | *5K | | | |
| V401 | 17JZ8 | VERT OSC & OUTPUT | 20 | †2.8M | | *340 | | †1.5M | 1.5M | *18 | 0 | †2.2M | 0 | 26 |
| V301 | 6CL8A | AGC & SOUND LIMITER | *58K | 3.8M | *70 | 20 | 17 | *600 | 15K | 0 | 220K | | | |
| V302 | 4AV6 | AUDIO AMP | †500K | 1.5K | 17 | 15 | 0 | 0 | 140K | | | | | |
| V303 | 12FX5 | AUDIO OUTPUT | 68 | 480K | 15 | 12 | 480K | *800 | *1K | | | | | |
| V202 | 4EJ7 | 2ND IF AMP | 100 | .1 | 100 | 10 | 12 | 0 | 470 | 470 | 0 | | | |
| V201 | 4EH7 | 1ST IF AMP | 55 | 1M | 55 | 9 | 10 | 0 | 470 | 12K | 0 | | | |
| V2 | 6CG8A | MIXER-OSC | 10 | *11K | 0 | 9 | 8 | *11K | 50K | 0 | 240K | | | |
| V1 | 3GK5 | RF AMP | 0 | 4M | 6 | 8 | *11K | 40K | 0 | | | | | |
| V3 | 3DZ4/3AF4 | UHF OSC | *5.6K | 6K | 5 | 6 | 0 | 6K | NC | | | | | |
| V402 | 8CG7 | HORIZ. OSC | *170K | †500K | 1.2K | 2.4 | 5 | *15K | 800K | 1.2K | | | | |
| V204 | 12BDP4 | CRT | 0 | 0 | 24K | *70 | | | †220K | 2.4 | | | | |

RESISTANCE MEASURED FROM TUBE PIN TO CIRCUIT GROUND (EXCEPT *)

* JUNCTION OF CD501 AND L501

† READING WILL VARY DEPENDING UPON SETTING OF ASSOCIATED CONTROLS

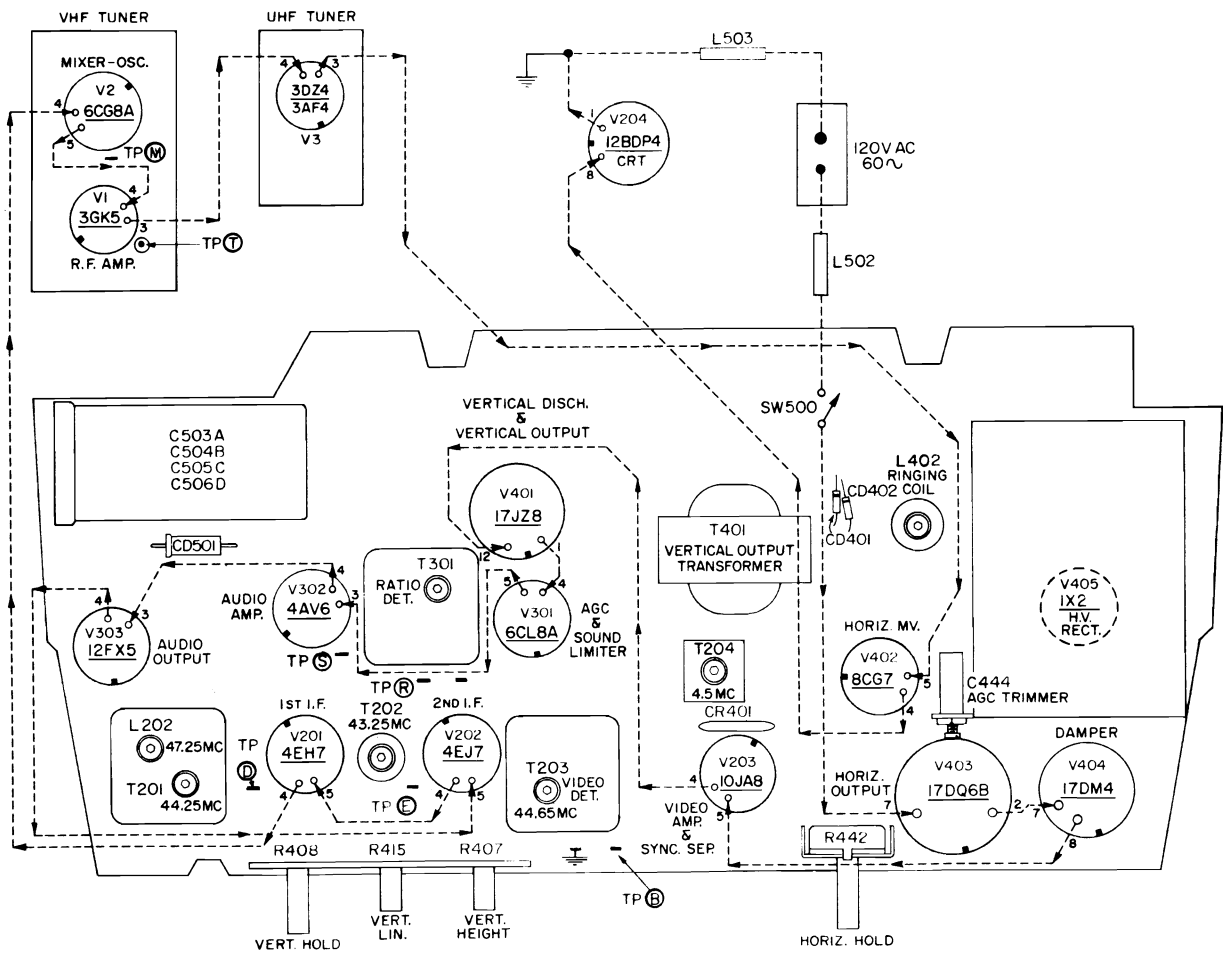

Figure 3 - Top View of Chassis.

VOLUME TV-24, ADDITIONAL 1965 TELEVISION SERVICING INFORMATION

WESTINGHOUSE Chassis V-2478-1, -2, Alignment Information, Continued

ALIGNMENT

SOUND ALIGNMENT

EQUIPMENT REQUIRED

1. 4.5 MC crystal-controlled signal generator.
2. VTVM.
3. Demodulator probe for VTVM.
4. Bias-voltage source (-4 volts).

PROCEDURE

1. Turn volume to minimum.
2. Inject a 4.5 MC CW signal, through a .0047 capacitor, at TP ⑥.
3. Connect the -4 volt bias source through a 39K resistor to TP ⑥. Connect the positive bias-source terminal to ground.
4. Set the VTVM to its -10 to -15 volt range, and connect it across TP ⑥ and ground.
5. With the signal-generator output at a low level, adjust the top slug of sound take-off coil T204 and ratio-detector coil T301 for maximum reading (max neg volts) on VTVM.

6. Disconnect the VTVM from TP ⑥.
7. Connect two 100K resistors in series across TP ⑥ and ground.
8. Set the VTVM for its lowest d-c range, and connect it across the center connection of the 100K resistors and TP ⑥ (see Figure 3).
9. With the signal-generator output at a high level, adjust the top slug (secondary) of ratio detector coil T301 for a zero reading on the VTVM.

4.5 MC TRAP ALIGNMENT

Disconnect the antenna and turn contrast control to maximum clockwise. Inject a 4.5 MC CW signal through a .001mf capacitor to TP ⑥. Connect a .001mf capacitor to a demodulation probe tip. Connect the other end of the probe to a VTVM and the capacitor to TP ⑥. Set the VTVM to 1.5-2V DC range. Turn the set on and allow ten minutes for warmup. Then adjust T203 bottom slug for minimum on the VTVM.

EQUIPMENT REQUIRED

1. Sweep Generator with a 10 MC wide sweep at center frequencies from 10 MC to 90 MC and 170 MC to 216 MC.
2. CW (Marker) Generator which accurately produces the IF and RF frequencies from 4.5 MC to 216 MC.
3. Oscilloscope with good low frequency response characteristics.
4. VTVM.
5. Bias Supply of -2.5 volts and -3 volts.
6. Standard Alignment Tool with a 3/32" hexagonal tip (long enough to reach bottom slugs).

TERMINATION AND ADJUSTMENT OF EQUIPMENT

These instructions on termination and adjustment of equipment will apply throughout the IF Alignment procedure.

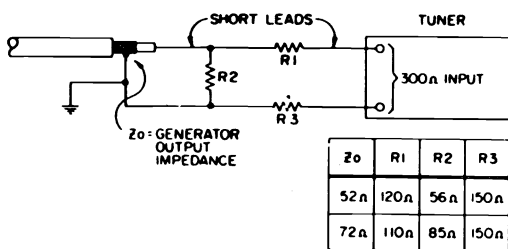

Figure 6 - Impedance Matching Network.

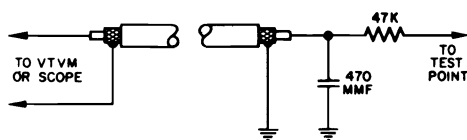

Figure 8 - VHF Decoupling Network.

IF ALIGNMENT

All test equipment cables and leads should be as short and direct as possible.

Oscilloscope and VTVM - Use a low-capacitance direct probe terminated with the decoupling network shown in Figure 8. Keep the oscilloscope calibrated for 2 volts peak to peak (P-P). Use a VTVM range suitable for measuring -1.5 volts.

Generators - Except where stated otherwise, all signal generating equipment should be terminated as shown in Figure 7. Connect the signal cable ground near the ground of the stage where the signal is injected.

Adjust the CW generator output so that: (1) When the VTVM is being used its reading remains near the -1 volt point. (2) When the oscilloscope is being used the marker frequencies do not distort the response curve.

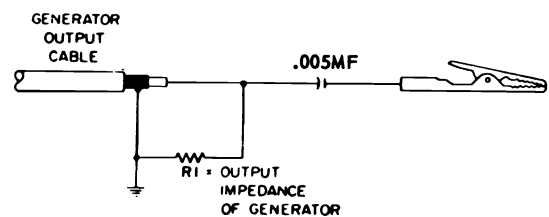

Figure 7 - Generator Cable Termination.

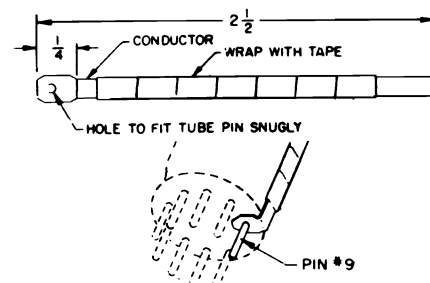

Figure 9 - Mixer Coupling Device.

VOLUME TV-24, ADDITIONAL 1965 TELEVISION SERVICING INFORMATION

WESTINGHOUSE Chassis V-2478-1,-2, Alignment Information, Continued

| Step | Test Equipment and Connection | Adjustment |
|------|---|--|
| 1. | -3V bias to TP ④ and -2.5V bias to TP ⑤. Short antenna terminals. Channel selector to channel 10. Connect jumper from bracket side of C444 to B- to disable the AGC pulse. | |
| 2. | Oscilloscope and VTVM to TP ⑥. IF sweep generator with CW marker to TP ⑦. a. 44.00 MC. b. 45.75 MC. | a. T203 primary (top slug): Maximum amplitude on VTVM. T203 secondary (bottom slug): Rocking symmetrical response at 44.00 MC. b. Place 45.75 MC marker at 70% of peak response (see Figure 10) for waveshape and marker placement. |
| 3. | CW generator to TP ⑧ at: 44.00 MC. | T20 : Maximum amplitude on VTVM. |
| 4. | CW generator to TP ⑨. Use mixer coupling device shown in Figure 10 : a. 44.30 MC. b. 44.30 MC. c. 47.25 MC. It may be necessary to increase generator output and/or decrease bias. | a. Tuner mixer output coil: Maximum on VTVM. b. T200: Maximum on VTVM. c. L201: Minimum on VTVM. |
| 5. | Connect sweep generator to TP ⑩ at 44.30 MC. Couple CW generator with marker at 44.30 MC to sweep generator cable. Keep marker amplitude low to avoid distorting response. Adjust scope for 2V PP. | Mixer output coil for maximum amplitude. T201 for "rocking symmetrical response with waveshape and markers" as shown in Figure 12. |
| 6. | CW generator to TP ⑪ at 47.25 MC. | Repeat step 4c. |
| 7. | Oscilloscope, 2V PP. Sweep generator thru impedance matching network (see Figure 6) to antenna terminals. Set pix marker at 211.25 MC, channel 13. Inject 45.75 MC marker into IF section by connecting CW output cable to outer shield of IF link cable. | Fine tuning to center of range. Channel selector to channel 13. Oscillator slug setting: Picture carrier should fall at 45.75 MC (± 300 KC) marker on scope (see Figure 13). |
| 8. | Repeat step 7 for all channels in descending order. | |

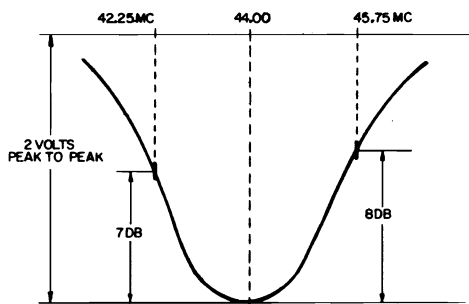

Figure 10 - Typical IF response, 2nd IF Amp Grid to 2nd Det.

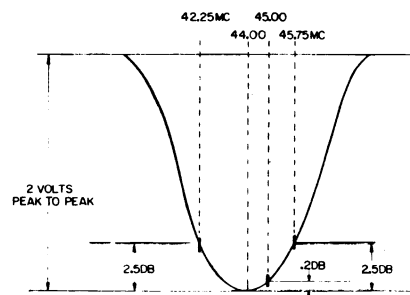

Figure 11 - Typical IF response, 1st IF Amp Grid to 2nd Det.

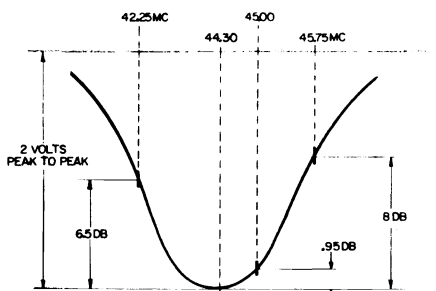

Figure 12 - Typical IF response, Mixer Amp grid to 2nd Det.

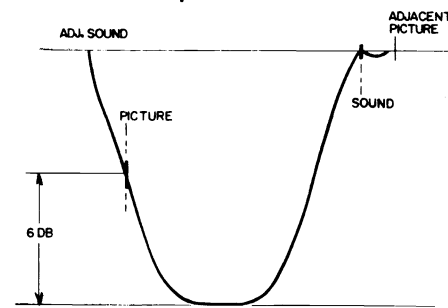

Figure 13 - Typical RF-IF response.

ZENITH RADIO CORPORATION



MODELS WITH CHASSIS 14M20, 14M23, 14M25, 14M27, 14M28, 14M29, 14M30, 14M31, 15M22, 16M24

MODEL AND CHASSIS INFORMATION

| MODEL | TYPE | CHASSIS | TUNING SYSTEM | SPACE COMMAND | PICTURE TUBE |
|---------------------------------|------------------|------------------------------|------------------------|---------------|--------------|
| H2200LU | Port. (Hospital) | 14M25 | Super Gold Video Guard | TT† | 19CXP4 |
| H2300LU | Portable | 14M31 | Deluxe Video Range | | 19DBP4 |
| L2004C3A, F3A, FU3A | Portable | 14M30 | Custom Channel | | 19CRP4 |
| M1615B, BU, L, LU, LU2 | Portable | 14M20 | Deluxe Video Range | | 16BCP4 |
| M1620Y, YU, YU2 | Portable | 14M20 | Deluxe Video Range | | 16BCP4 |
| M2000CU, CUA | Portable | 14M29 | Deluxe Video Range | | 19DBP4 |
| M2001C, CU, CUA, L, LU, LUA | Portable | 14M29 | Deluxe Video Range | | 19DBP4 |
| M2002F, FU, FUA, L, LU, LUA | Portable | 14M29 | Deluxe Video Range | | 19DBP4 |
| M2003H, HU, W, WU | Portable | 14M28 | Deluxe Video Range | | 19DBP4 |
| M2012J, JU, L | Portable | 14M27 | Custom Video Range | | 19CXP4 |
| M2014R, RU, W, WU | Portable | 14M27 | Super Video Guard | | 19CXP4 |
| M2109F, FU, L, LU | Portable | 14M28 | Super Gold Video Guard | | 19EKP4 |
| M2110HU, WU | Portable | 14M28 | Super Gold Video Guard | TT† | 19EKP4 |
| M2127LU, WU | Portable | 14M27 | Super Video Guard | | 19CXP4 |
| M2150L, LU, Y, YU | Portable | 14M20 | Deluxe Video Range | | 19DBP4 |
| M2155BU, JU, LU, Y, YU | Portable | 14M20 | Deluxe Video Range | | 19DBP4 |
| M2210G, GU, J | Portable | 14M28 | Super Gold Video Guard | 300 | 19EKP4 |
| M2214LU | Portable | 14M28 | Super Gold Video Guard | 300 | 19EKP4 |
| M2231LU, RU, W, WU | Portable | 14M27 | Super Video Guard | 300 | 19CXP4 |
| M2705R, RU, Y, YU | Table | 14M23 | Deluxe Video Range | | 23EYP4 |
| M2706FU, LU | Table | 14M23 | Deluxe Video Range | | 23EYP4 |
| M2708RU, W, WU | Table | 14M23 | Deluxe Video Range | | 23EYP4 |
| M2717RU, W, WU | Table | 15M22 | Super Gold Video Guard | TT† | 23FNP4 |
| M2733R, RU, W, WU | Console | 14M23 | Custom Video Range | | 23EYP4 |
| M2735E, EU, LU, R, RU, W, WU | Console | 14M23 | Custom Video Range | | 23EYP4 |
| M2736EU, RU, W, WU | Console | 14M23 | Custom Video Range | | 23EYP4 |
| M2737HU, HFU, MU, RU, W, WU | Console | 14M23 | Super Video Guard | | 23EYP4 |
| M2738EU, RU, W, WU | Console | 14M23 | Super Video Guard | | 23EYP4 |
| M2742HU, MU, RU, WU | Console | 15M22 | Super Gold Video Guard | TT† | 23FNP4 |
| M3311W, WU, YU | Table | 15M22 | Super Video Guard | 400 | 23FNP4 |
| M3350WU | Console | 15M22 | Super Gold Video Guard | 400 | 23FNP4 |
| M3352MU | Console | 15M22 | Super Gold Video Guard | 400 | 23FNP4 |
| M3355HU | Console | 15M22 | Super Gold Video Guard | 400 | 23FNP4 |
| MM2784W, WU, RU | Combo. | 16M24 & 9M1T22Z 9M1T22 | Super Video Guard | | 23EYP4 |
| MM2785HU, MU, RU | Combo. | 16M24 & 9M1T23 9M1T23Z | Super Video Guard | | 23EYP4 |
| RM2784RU, WU | Combo. | 16M24 & 7L22 | Super Video Guard | | 23EYP4 |
| SA2032RU6, WU6 | Console | 14M23 | Super Video Range | | 23EYP4 |
| T1978GU, LU | Portable | 14M29 | Deluxe Video Range | | 19DBP4 |

(Model and Chassis Information continued on page 172)

VOLUME TV-24, ADDITIONAL 1965 TELEVISION SERVICING INFORMATION

ZENITH Model and Chassis Information, Continued

| MODEL | TYPE | CHASSIS | TUNING SYSTEM | SPACE COMMAND | PICTURE TUBE |
|-----------------------|----------|---------|--------------------|---------------|--------------|
| T1981CA, CUA, GA, GUA | Portable | 14M30 | Deluxe Video Range | | 19CRP4 |
| T1986CU, JU | Portable | 14M27 | Deluxe Video Range | | 19CXP4 |
| T1989RU, WU | Portable | 14M27 | Super Video Guard | | 19CXP4 |
| T1997FU, JU | Portable | 14M27 | Super Video Guard | | 19DBP4 |
| T2015RU, W, WU | Console | 14M23 | Super Video Range | | 23EYP4 |
| T2018RU, W, WU | Console | 14M23 | Super Video Range | | 23EYP4 |
| T2020RU, W, WU | Console | 14M23 | Super Video Range | | 23EYP4 |
| T2028W, WU6 | Console | 14M23 | Super Video Guard | | 23EYP4 |
| T2029H6, HU6, R6, RU6 | Console | 14M23 | Super Video Guard | | 23EYP4 |
| T2030MU6, W6 | Console | 14M23 | Super Video Guard | | 23EYP4 |
| T2045RU6, WU6 | Console | 14M23 | Super Video Range | | 23EYP4 |

ADDITIONAL MODELS RECENTLY RELEASED

| MODEL | TYPE | CHASSIS | VHF TUNER | SPACE COMMAND | PICTURE TUBE |
|-------------------------------------|-------------|------------------|------------------------|---------------|--------------|
| H2200LU4 | Hospital | 14M25 | Super Gold Video Guard | TT | 19CXP4 |
| H2300LU4 | Hotel-Motel | 14M31 | DeLuxe Video | | 19DBP4 |
| M2000C, C1, CUI, CUIA | Portable | 14M29 | DeLuxe Video | | 19DBP4 |
| M2000C4, CU4 | Portable | 14M29Z | Custom Video | | 19DBP4 |
| M2001C1, CUI, CUIA, LI, LUI, LUIA | Portable | 14M29 | DeLuxe Video | | 19DBP4 |
| M2002F1, FU1, FUIA, LI, LUIA | Portable | 14M29 | DeLuxe Video | | 19DBP4 |
| M2003HU1, W1, WU1 | Portable | 14M28 | DeLuxe Video | | 19DBP4 |
| M2004J4, JU4, LU4 | Portable | 14M27 | DeLuxe Video | | 19CXP4 |
| M2005HU4, W4, WU4 | Portable | 14M28Z | DeLuxe Video | | 19DBP4 |
| M2014RU4, W4, WU4 | Portable | 14M27 | Super Gold Video Guard | | 19CXP4 |
| M2109F4, FU4, L4, LU4 | Portable | 14M28 | Super Gold Video Guard | | 19E ZP4 |
| M2110HU4, WU4 | Portable | 14M28 | Super Gold Video Guard | TT | 19E ZP4 |
| M2127W4, WU4 | Portable§ | 14M27 | Super Gold Video Guard | | 19CXP4 |
| M2150L4, LU4 | Portable | 14M20Z | DeLuxe Video | | 19E ZP4 |
| M2155Y4, YU4 | Portable | 14M20Z | DeLuxe Video | | 19E ZP4 |
| M2210G4, GU4 | Portable | 14M28Z | Super Gold Video Guard | 300 | 19E ZP4 |
| M2214LU4 | Portable | 14M28 | Super Gold Video Guard | 300 | 19E ZP4 |
| M2231LU4, W4, WU4 | Portable§ | 14M27 | Super Gold Video Guard | 300 | 19CXP4 |
| M2705R4, RU4, Y4, YU4 | Table | 14M23Z | DeLuxe Video | | 23EYP4 |
| M2706F, L | Table | 14M23 | DeLuxe Video | | 23EYP4 |
| M2706F4, FU4, L4, LU4 | Table | 14M23Z | DeLuxe Video | | 23EYP4 |
| M2708RU4, W4, WU4 | Table | 14M23Z | DeLuxe Video | | 23EYP4 |
| M2733H4, HU4, MU4, R4, RU4, W4, WU4 | Console | 14M23Z | Custom Video | | 23EYP4 |
| M2735EU4, R4, RU4, W4, WU4 | Console | 14M23Z | Custom Video | | 23EYP4 |
| M2736E4, EU4, RU4, W4, WU4 | Console | 14M23Z | Custom Video | | 23EYP4 |
| M2737HFU4, HU4, MU4, RU4, WU4 | Console | 14M23Z | Super Gold Video Guard | | 23EYP4 |
| M2738EU4, RU4, W4, WU4 | Console | 14M23Z | Super Gold Video Guard | | 23EYP4 |
| M3333RU, WU | Console | 14M23 | Super Gold Video Guard | | 23EYP4 |
| M3333HU4, MU4, RU4, WU4 | Console | 14M23Z | Super Gold Video Guard | 300 | 23EYP4 |
| MM2780WU4 | Console | 16M24 9MIT22Z | Super Gold Video Guard | 400 | 23FNP4 |
| MM2781HU4, RU4 | Console | 16M24 9MIT22Z | Super Gold Video Guard | | 23EYP4 |
| MM2782MU4 | Console | 16M24 9MIT22Z | Super Gold Video Guard | | 23EYP4 |
| M2784WU4 | Console | 16M24 9MIT22Z | Super Gold Video Guard | | 23EYP4 |
| RM2780WU4 | Console | 16M24 7L22 | Super Gold Video Guard | | 23EYP4 |
| RM2781HU4, RU4 | Console | 16M24 7L22 | Super Gold Video Guard | | 23EYP4 |

VOLUME TV-24, ADDITIONAL 1965 TELEVISION SERVICING INFORMATION

ZENITH Chassis 14M20, 14M31, 15M22, 16M24, Continued

| MODEL | TYPE | CHASSIS | VHF TUNER | SPACE COMMAND | PICTURE TUBE |
|------------------------|----------|---------------|------------------------|---------------|--------------|
| RM2782MU4 | Console | 16M24 7L22 | Super Gold Video Guard | | 23EYP4 |
| SA2034RU, RUA, WU, WUA | Console | 14M23 | Super Video Turret | | 23EYP4 |
| T1978GU1, LU1 | Portable | 14M29 | DeLuxe Video | | 19CRP4 |
| T1978GU4, LU4 | Portable | 14M29Z | DeLuxe Video | | 19DBP4 |
| T1981CU6, GU6 | Portable | 14M30 | DeLuxe Video | | 19CRP4 |
| T1982JU, JU1 | Portable | 14M28 | DeLuxe Video | | 19DBP4 |
| T1986CU4, JU4, WU, WU4 | Portable | 14M27 | DeLuxe Video | | 19CXP4 |
| T1989RU4, WU4 | Portable | 14M27 | Super Gold Video Guard | | 19CXP4 |
| T2015RU4, W4, WU4 | Console | 14M23Z | Custom Video Turret | | 23EYP4 |
| T2018WUA | Console | 14M23 | Super Video Turret | | 23EYP4 |
| T2020WUA | Console | 14M23 | Super Video Turret | | 23EYP4 |
| T2020W4, WU4 | Console | 14M23Z | Custom Video Turret | | 23EYP4 |
| T2028W6 | Console | 14M23 | Super Gold Video Guard | | 23EYP4 |
| T2035 WU 4 | Console | 14M23Z | Custom Video Turret | | 23EYP4 |
| T2036HU4, RU4 | Console | 14M23Z | Custom Video Turret | | 23EYP4 |
| T2044RU4, WU4 | Console | 14M23Z | Custom Video Turret | | 23EYP4 |

Chassis with suffix "Z" are the same as those without the suffix excepting a few parts and minor differences in parts layout. Picture tube may also differ.

CENTERING ADJUSTMENT

The centering assembly is built into the yoke housing. This assembly is made of two magnetic rings which can be rotated by means of tabs. Centering is accomplished by gradually rotating each tab separately and/or rotating both tabs simultaneously until the picture is centered.

SOUND ADJUSTMENTS

Proper alignment of the 4.5 Mc intercarrier sound channel can only be made if the signal to the receiver antenna terminals is reduced to a level below the limiting point of the Gated Beam Sound Detector. This level can be easily identified by the "hiss" that accompanies the sound. Various methods may be used to reduce the signal level; however, a step attenuator is recommended for most satisfactory results. Alignment is made as follows:

1. Connect the step attenuator between the antenna and the receiver antenna terminals.

2. Tune in a TV signal. Adjust the step attenuator until the signal is attenuated to a level where a "hiss" is heard with the audio.

3. Adjust the sound take-off coil (top and bottom cores), intercarrier transformer, quadrature coil and buzz control for the best quality sound and minimum buzz. It must be remembered that any of these adjustments may cause the "hiss" to disappear and further reduction of the signal will be necessary to prevent the "hiss" from disappearing during alignment.

A suitable VHF and UHF sweep generator in conjunction with an accurate marker must be used for IF and tuner alignment work. It is extremely important to terminate the output cable properly and to check for a reactive attenuator. If the attenuator is reactive or if the output cable is improperly terminated, correct alignment cannot be made since the degree of attenuation may change the shape as well as the amplitude of the response curve. The attenuator should only vary the amplitude and not the shape of the response curve.

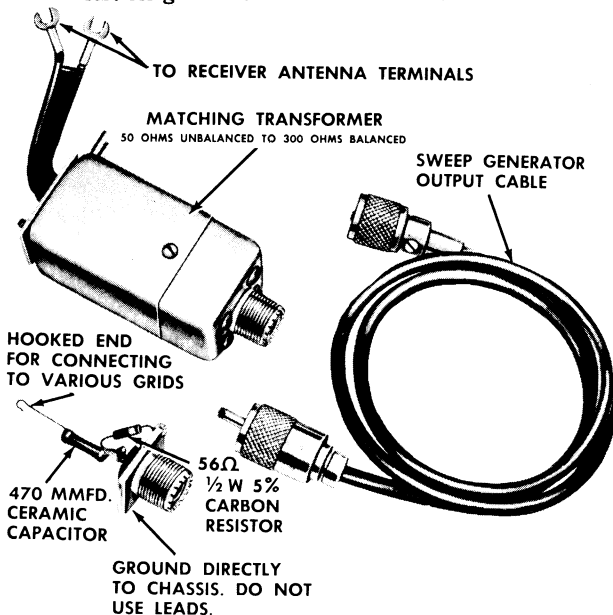

Fig. 4 IF-RF Alignment Fixtures

VIDEO IF ALIGNMENT

14M23, 14M28, 15M22 & 16M24 CHASSIS

Refer to the appropriate schematic diagram, tube and trimmer layout, and tuner drawings for reference test points.

1.
 - (a) On the 700 series tuners; slowly turn the channel selector until it rests between channels 12 and 13. This will prevent an erroneous response.
 - (b) On the 440, 600 & 750 series; turn the selector until it rests on channel 13.
 - (c) On the 500 series; turn the selector until it rests between any two channels.

ZENITH Chassis 14M20, 14M31, 15M22, 16M24, Alignment, Continued

2. Connect an oscilloscope through a 10,000 ohm isolation resistor to terminal "C" (detector). Connect the ground lead to chassis. In the 15M22, 14M23 and 16M24 chassis, turn the peak picture control to the extreme counterclockwise position. In the 14M28 chassis, the control should be set at mid range.

3. Feed the sweep generator through a special terminating network as shown in Fig. 4 to Point "G" (Grid of the 3rd IF). Adjust generator to obtain a response similar to Fig. 5 with a detector output of 3 volts peak to peak. Do not exceed this level during any of the adjustments.

4. Set the marker generator to 45.75 Mc and alternately adjust the top and bottom cores of the 4th IF for maximum gain and symmetry with the 45.75 Mc marker positioned as shown in Fig. 5. The two peaks must be equal in height and the high frequency

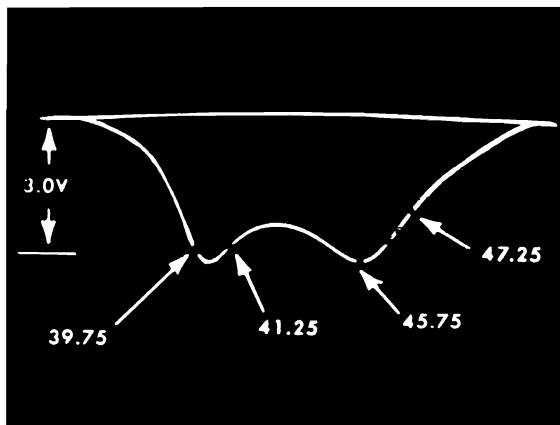

Fig. 5 4th IF Response

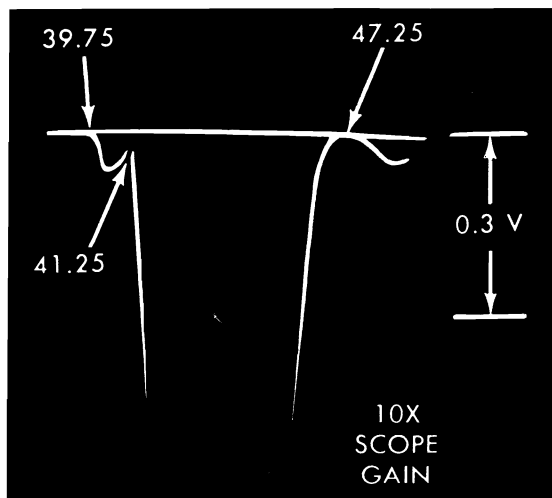

Fig. 6 Expanded View of Traps

peak at 45.75 Mc. If the correct response cannot be obtained, check the position of the cores to see that they are not butted. The cores should be entering their respective windings from the opposite ends of the coils.

5. Connect the sweep generator to terminal "A" (converter grid). Connect terminal "F" to chassis and connect a jumper between terminal "E" and chassis. Adjust the sweep to obtain a 3V.P.P. response similar to Fig. 8. Switch oscilloscope to 10X gain to "blow up" the traps, (Fig. 6).

6. Refer to Fig. 6 and adjust the 39.75 Mc and the 41.25 Mc traps for minimum marker amplitude. Disconnect the jumper between "E" and chassis. Connect this jumper between "E" and the junction of the 22 (68 in the 14M28 chassis) and 1800 ohm resistors in the cathode of the first IF. This provides an additional "blow up" of the 47.25 Mc traps (Fig. 7). Adjust the 47.25 Mc traps (the 14M23, 14M28 and 16M24 chassis have one 47.25 Mc trap and the 15M22 has two) for minimum marker amplitude.

7. Disconnect the jumper between "E" and the 22 and 1800 ohm cathode resistors. Connect this jumper between "E" and chassis. Adjust sweep generator for 3 volts peak to peak output at the second detector. Alternately adjust the 2nd, 3rd, 1st IF and the converter plate coil until an overall response similar to Fig. 8 (Fig. 9 for the 14M28 chassis) is obtained. It will be found that the 2nd IF affects the low side (42.75 Mc) and the 3rd IF, the high side of the response.

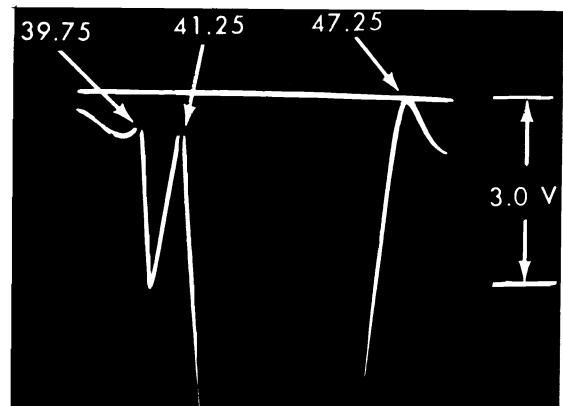

Fig. 7 Further Expansion of Fig. 6 for Detail View of the 39.75 and 47.25 Mc Traps.

VIDEO IF ALIGNMENT

14M20, 14M25, 14M27, 14M29, 14M30 & 14M31

Refer to the appropriate schematic diagram, chassis tube and trimmer layout, and tuner drawings for reference test points.

1. Slowly turn the channel selector until the tuner rotor is made to rest between two channels. This will prevent an erroneous response.

2. Connect an oscilloscope through a 10,000 ohm isolation resistor to terminal "C" (detector). Connect the ground lead to chassis. In the 14M27, 14M25 and 14M30 chassis, set the peak picture control to mid-range.

VOLUME TV-24, ADDITIONAL 1965 TELEVISION SERVICING INFORMATION

ZENITH Chassis 14M20, 14M31, 15M22, 16M24, Alignment, Continued

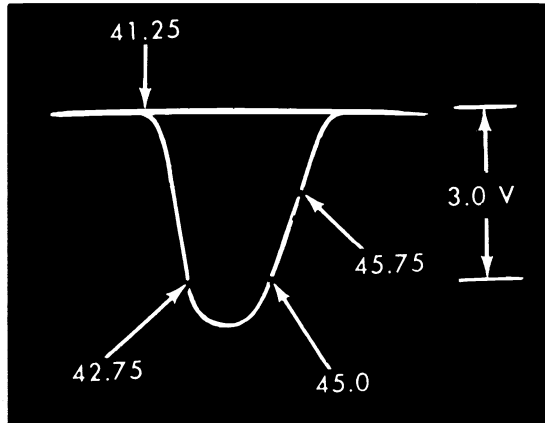

Fig. 8 Overall IF Response

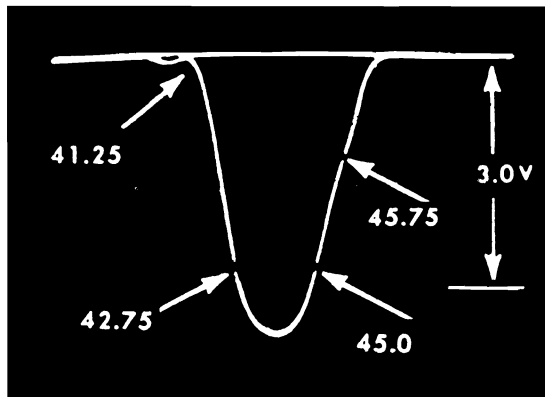

Fig. 9 Overall IF Response
14M28 CHASSIS

3. Feed the sweep generator through a special terminating network as shown in Fig. 4 to Point "G" (Pin 1 of the 3rd IF). Adjust generator to obtain a response similar to Fig. 10. Do not exceed the 3 volt peak to peak detector output during any of the following adjustments.

4. Set the marker generator to 45.75 Mc and alternately adjust the top and bottom cores of the 4th IF for maximum gain and symmetry with the 45.75 Mc and the 42.75 Mc markers positioned as shown in

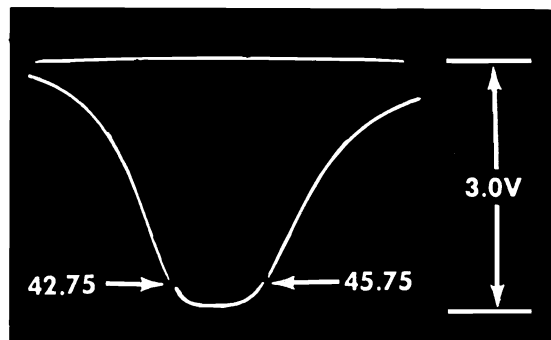

Fig. 10 4th IF Response

Fig. 10. If the correct response cannot be obtained, check the cores to see that they are not butted but are entering their respective windings from the opposite ends of the coil.

5. Connect the sweep generator to terminal "A" (converter grid. Refer to appropriate tuner tube and trimmer layout). Connect terminal "F" to chassis and connect a jumper between terminal "E" and the bottom end of the 68 ohm resistor in the cathode of the first IF. This provides a "Blow Up" of the 47.25 Mc trap (Fig. 11). Adjust the 47.25 Mc trap for minimum marker amplitude.

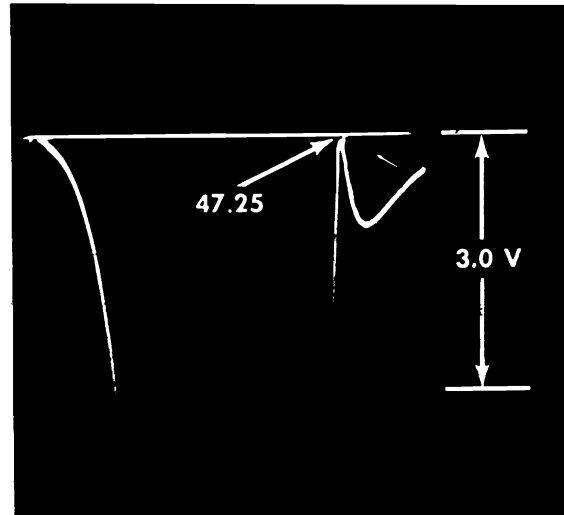

Fig. 11 Expanded view of the 47.25 Mc Trap.

6. Disconnect the jumper between "E" and the bottom end of the 68 ohm cathode resistor. Connect this jumper between "E" and the chassis. Adjust sweep generator for 3 volts peak to peak output at the second detector. Alternately adjust the 2nd, 3rd, 1st IF and the converter plate coil until an overall response similar to Fig. 12 is obtained. It will be found that the 2nd IF affects the low side (42.75 Mc) and the 3rd IF the high side of the response. Remove jumpers after alignment.

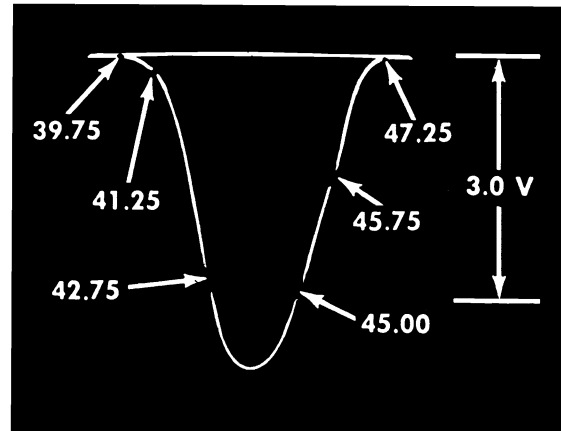
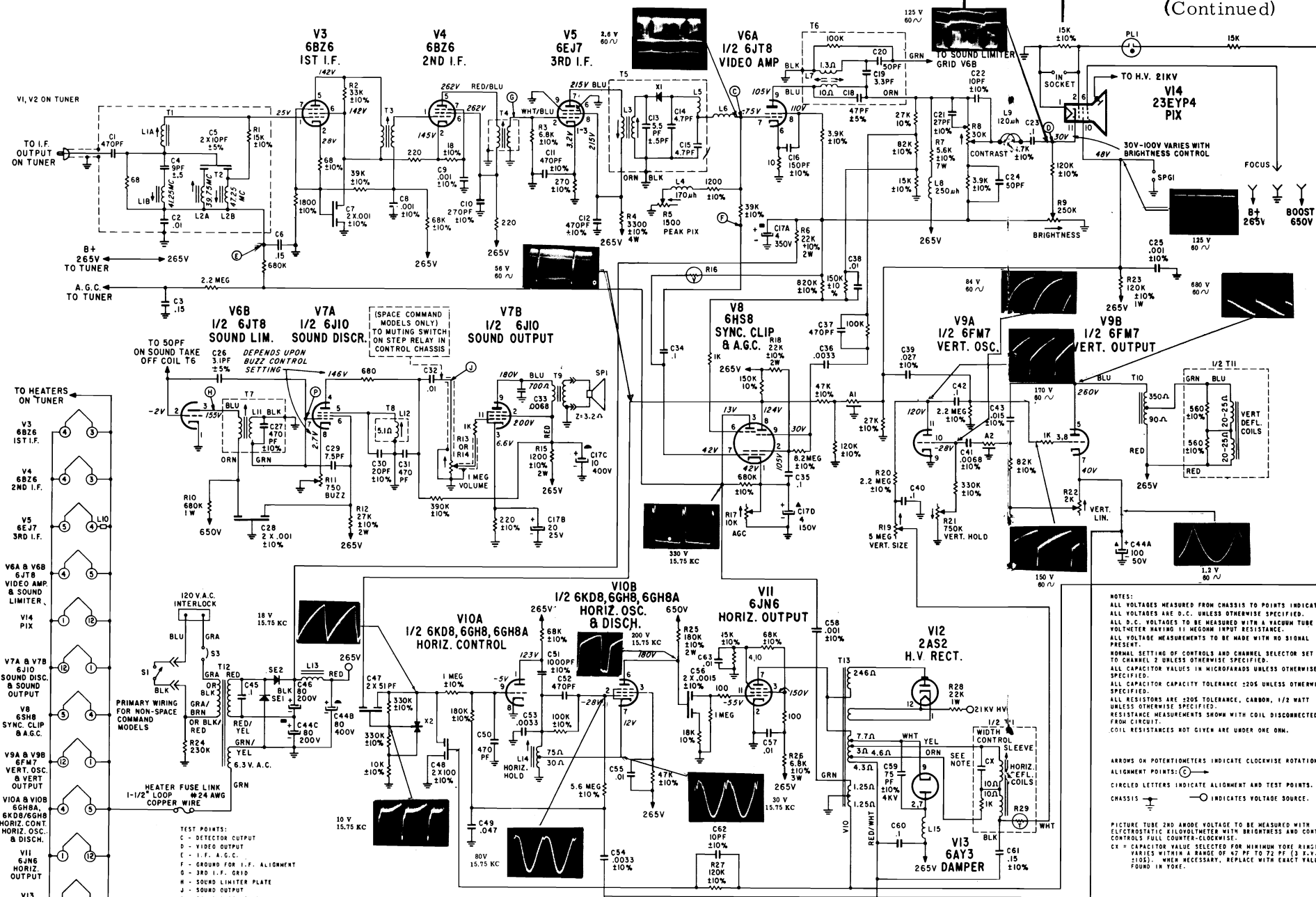
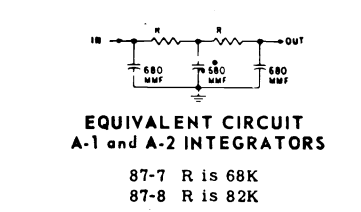
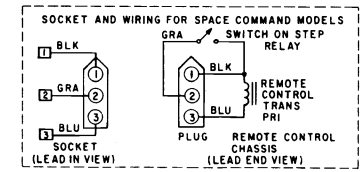

Fig. 12 Overall IF Response

Schematic of 14M23 Chassis, Showing Representative Waveforms and Peak To Peak Voltages of Other M-Chassis



TEST POINTS:
 C - DETECTOR OUTPUT
 D - VIDEO OUTPUT
 E - I.F. A.G.C.
 F - GROUND FOR I.F. ALIGNMENT
 G - 3RD I.F. GRID
 H - SOUND LIMITER PLATE
 J - SOUND OUTPUT
 K - SOUND DISC. GRID



AGC ADJUSTMENT

Tune in a strong TV signal and slowly turn the AGC control until a point is reached where the picture distorts and buzz is heard in the sound. The control should then be backed down from this position and set at a point comfortably below the level of intercarrier buzz, picture distortion and improper sync.

This setting corresponds with 2.5 V peak to peak output from the video detector (3 to 3.5 V p.p. in the 14M20, 14M29, 14M30, and 14M31).

CAUTION: Misadjustment of the AGC control can result in a washed-out picture, distorted picture, buzz in the sound or complete loss of picture and sound.

ZENITH Chassis 14M23 Schematic Diagram

(Continued)

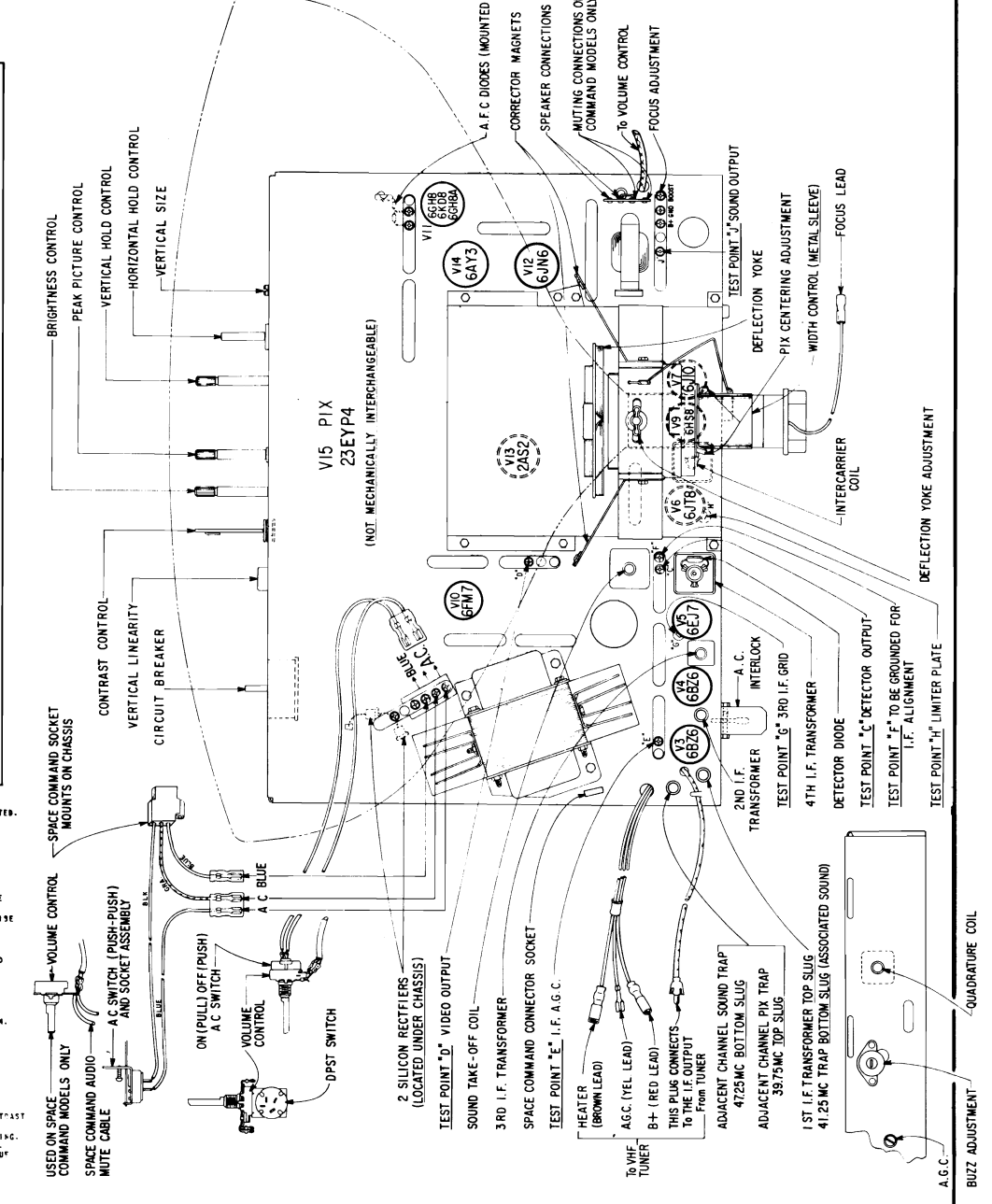

NOTES:
 ALL VOLTAGES MEASURED FROM CHASSIS TO POINTS INDICATED.
 ALL VOLTAGES ARE D.C. UNLESS OTHERWISE SPECIFIED.
 ALL D.C. VOLTAGES TO BE MEASURED WITH A VACUUM TUBE VOLTMETER HAVING 11 MEGOHM INPUT RESISTANCE.
 ALL VOLTAGE MEASUREMENTS TO BE MADE WITH NO SIGNAL PRESENT.
 NORMAL SETTING OF CONTROLS AND CHANNEL SELECTOR SET TO CHANNEL 2 UNLESS OTHERWISE SPECIFIED.
 ALL CAPACITOR VALUES IN MICROFARADS UNLESS OTHERWISE SPECIFIED.
 ALL CAPACITOR CAPACITY TOLERANCE .20% UNLESS OTHERWISE SPECIFIED.
 ALL RESISTORS ARE 200K TOLERANCE, CARBON, 1/2 WATT UNLESS OTHERWISE SPECIFIED.
 RESISTANCE MEASUREMENTS SHOWN WITH COIL DISCONNECTED FROM CIRCUIT.
 COIL RESISTANCES NOT GIVEN ARE UNDER ONE OHM.

ARROWS ON POTENTIOMETERS INDICATE CLOCKWISE ROTATION.
 ALIGNMENT POINTS: ○
 CIRCLED LETTERS INDICATE ALIGNMENT AND TEST POINTS.
 CHASSIS: ⊕
 ○ INDICATES VOLTAGE SOURCE.

CORRECTOR MAGNET ADJUSTMENT

Two corrector magnets are used in all 23 inch models to obtain straight, sharply focused sweep lines across the face of the picture tube. The magnets are mounted on the deflection coil support bracket. Adjustment is made by bending the flexible arms sideways and up and down. Correct adjustment has been made at the factory and readjustment should not be required unless the brackets have been accidentally bent out of position. If this occurs, proceed as follows:

1. With the vertical and horizontal size controls,

reduce the size of the picture to a point where the four corners and sides are visible. (In some receivers it is not possible to reduce the picture sufficiently to see all sides and it may be necessary to shift the picture with the centering control to view one side at a time.)

2. Bend the corrector magnet arms until the corners become right angles and the top of the raster is parallel with the bottom and the left side is parallel with the right side. After adjustment, the picture should be restored to normal size.

NOTE: Misadjustment of the corrector magnets may cause pincushioning, barreling, keystoneing, poor linearity, etc.

TELEVISION SERVICING INFORMATION

ZENITH Chassis 14M20
Schematic Diagram
Chassis 14M29 and 14M31
are practically identical.

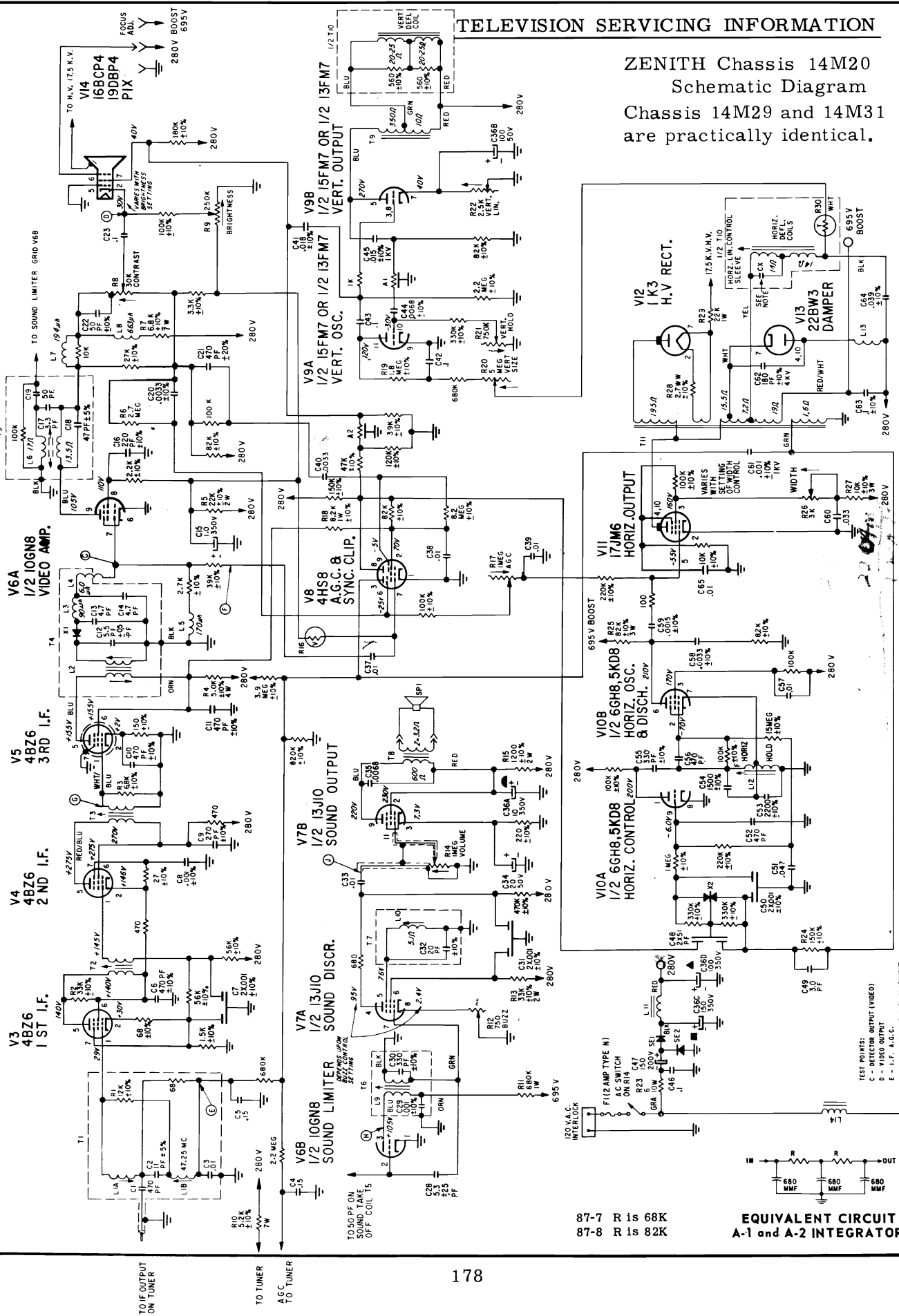

Schematic of 14M20 Chassis. Also, Chassis Layout and Signal Path Diagrams.

87-7 R is 68K
87-8 R is 82K

EQUIVALENT CIRCUIT
A-1 and A-2 INTEGRATORS

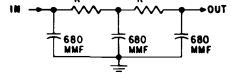

- C - DETECTOR OUTPUT (VIDEO)
- D - VIDEO OUTPUT
- E - I.F. A.G.C.
- F - GROUND DURING I.F. ALIGNMENT
- G - 3RD I.F. GRID
- H - SOUND LIMITER PLATE
- J - SOUND OUTPUT

ZENITH

87-7 R is 68K
87-10 R is 82K

EQUIVALENT CIRCUIT
A-1 and A-2 INTEGRATORS

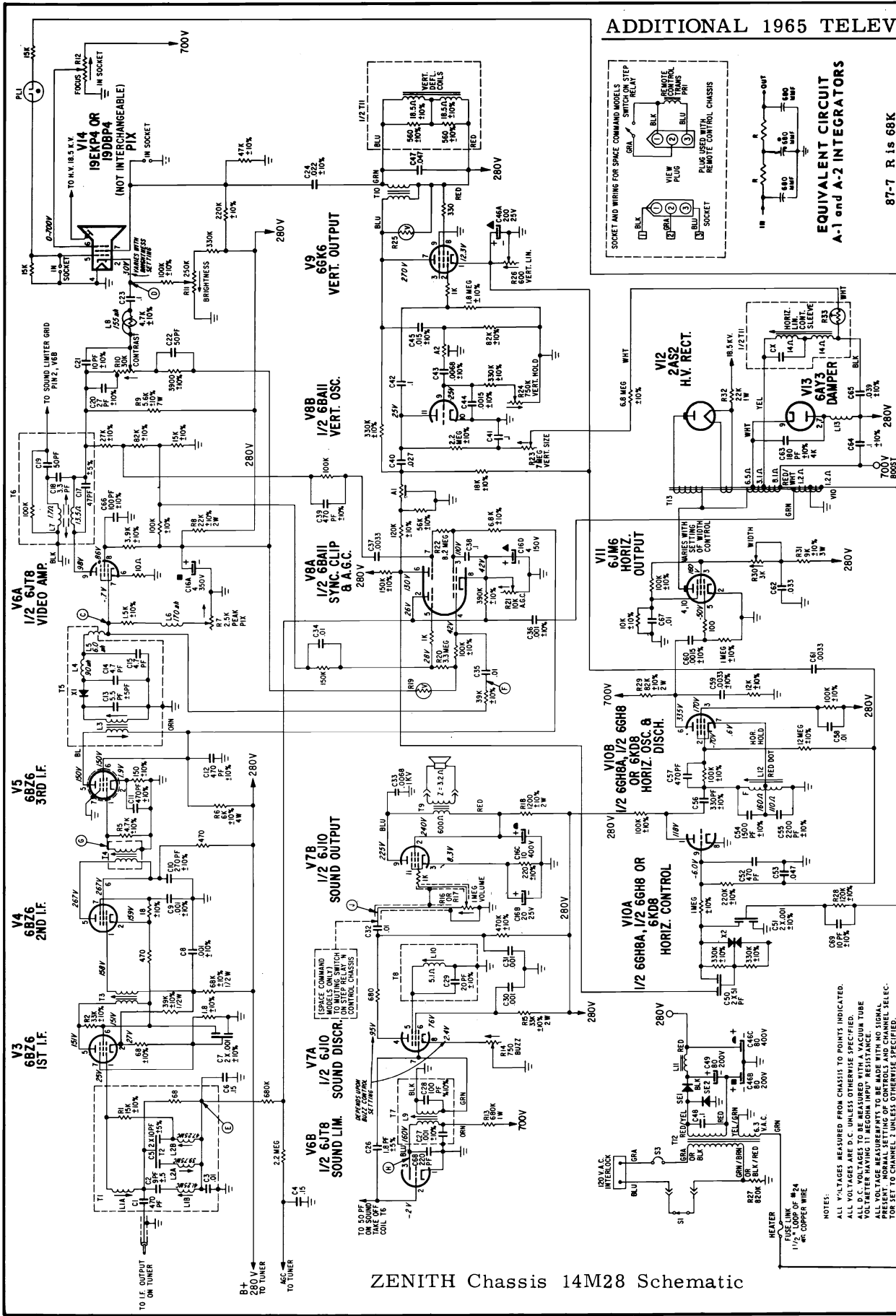
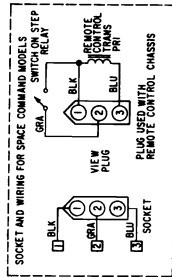

CIRCLED LETTERS INDICATE ALIGNMENT AND TEST POINTS WHERE APPLICABLE.
 C - DETECTOR OUTPUT
 D - I.F. AGC
 E - I.F. AGC
 F - GROUNDED FOR I.F. ALIGNMENT
 G - 3RD I.F. GRID PLATE
 H - DETECTOR OUTPUT
 I - I.F. AGC
 J - SOUND OUTPUT

/P/ ON POTENTIOMETERS INDICATE CLOCKWISE ROTATION.
 CHASSIS
 O - INDICATES VOLTAGE SOURCE.
 FIGURE IN CIRCLE INDICATES VOLTAGE TO BE MEASURED WITH VOLT-METER HAVING 1% RESISTANCE.
 C - CAPACITOR VALUE SELECTED FOR MINIMUM CORE RINGING. WHEN NECESSARY, REPLACE WITH EXACT VALUE FOUND IN TUBE.

NOTES:
 ALL VOLTAGES MEASURED FROM CHASSIS TO POINTS INDICATED.
 ALL VOLTAGES ARE D.C. UNLESS OTHERWISE SPECIFIED.
 ALL D.C. VOLTAGES TO BE MEASURED WITH A VACUUM TUBE VOLTMETER HAVING 1% RESISTANCE.
 PRESENT NORMAL SETTING OF CONTROLS AND CHANNEL TELEVISION SET TO CHANNEL 3 UNLESS OTHERWISE SPECIFIED.
 ALL CAPACITORS - UNLESS IN MICROFARADS UNLESS OTHERWISE SPECIFIED.
 ALL CAPACITOR CAPACITY TOLERANCES 20% UNLESS OTHERWISE SPECIFIED.
 ALL RESISTORS ARE 20% TOLERANCE, CARBON, 1/2 WATT UNLESS OTHERWISE SPECIFIED.
 RESISTANCE MEASUREMENTS IN OHMS WITH COIL DISCONNECTED FROM CIRCUIT.
 COIL RESISTANCES NOT GIVEN ARE UNDER ONE OHM.
 CATHODE RAY TUBE 2ND ANODE VOLTAGE TO BE MEASURED ELECTROSTATIC OR 20 K MIN. ONE PER VOLT HIGH VOLTAGE METER.

ZENITH Chassis 14M28 Schematic

VOLUME TV-24, ADDITIONAL 1965 TELEVISION SERVICING INFORMATION

ZENITH Chassis 14M28 Service Information, Continued

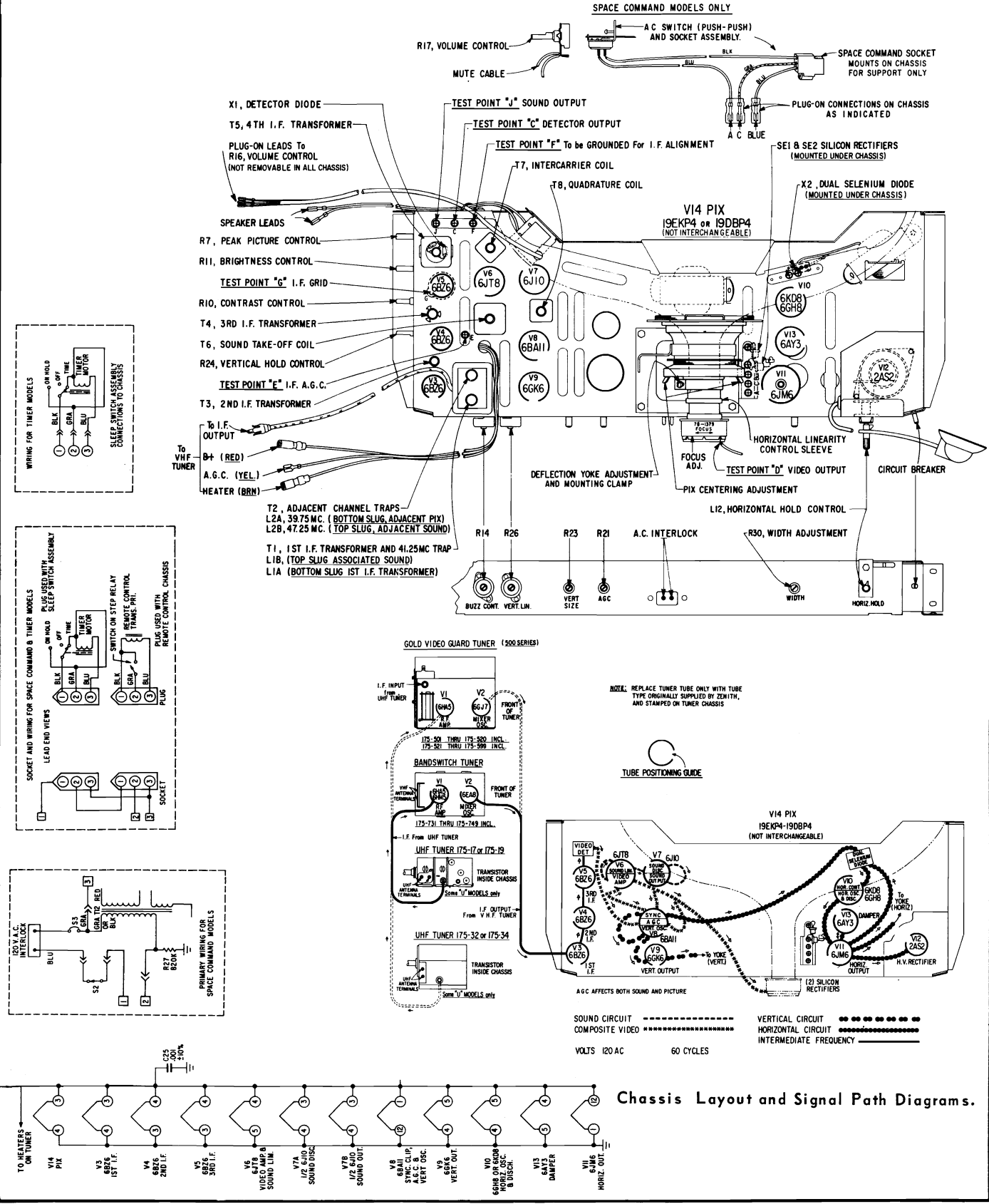

Chassis Layout and Signal Path Diagrams.

VOLUME TV-24, ADDITIONAL 1965 TELEVISION SERVICING INFORMATION

ZENITH Chassis 14M30 Service Information

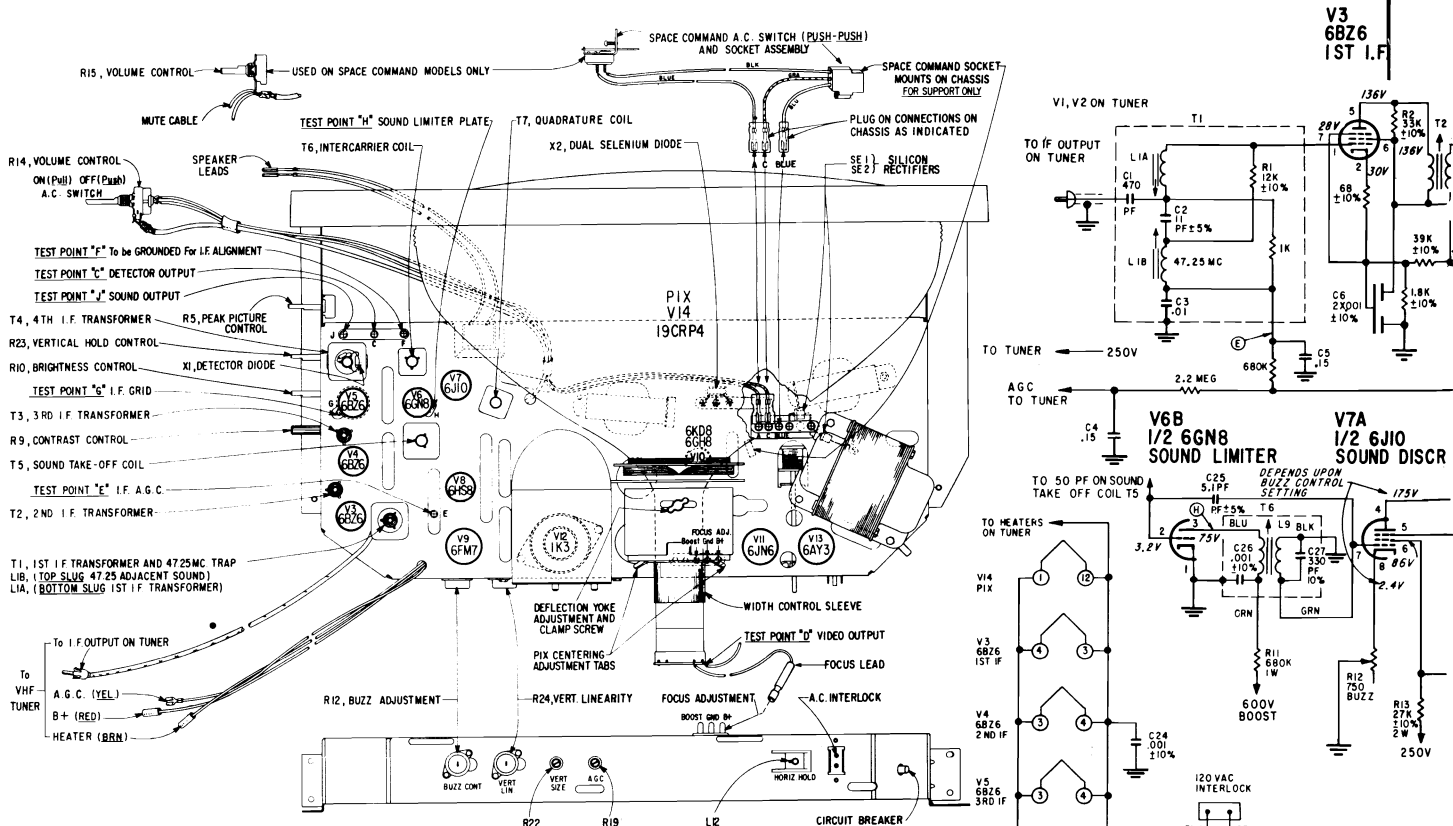

Schematic of 14M30 Chassis. Also, Chassis Layout and Signal Path Diagrams.

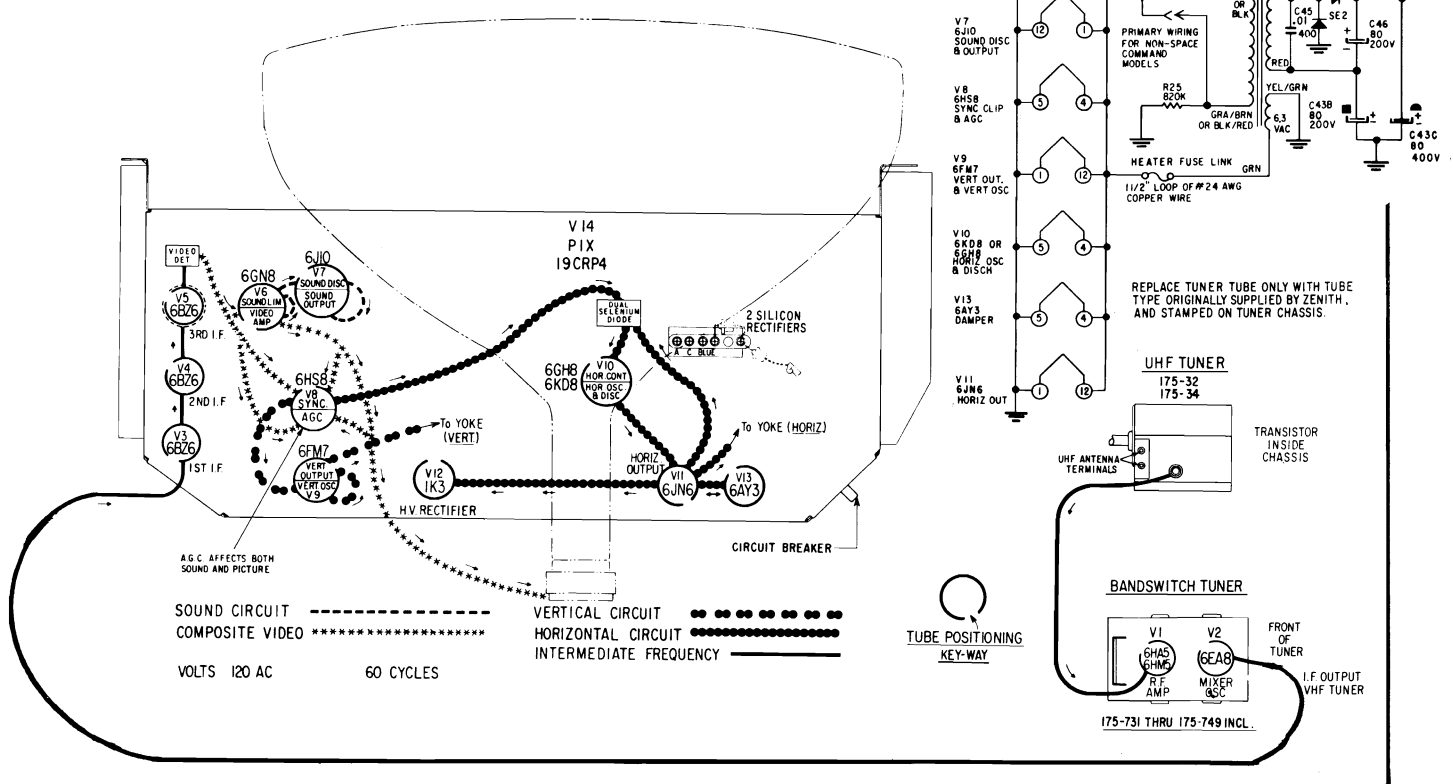

VOLUME TV-24, ADDITIONAL 1965 TELEVISION SERVICING INFORMATION

ZENITH Chassis 14M30 Schematic Diagram, Continued

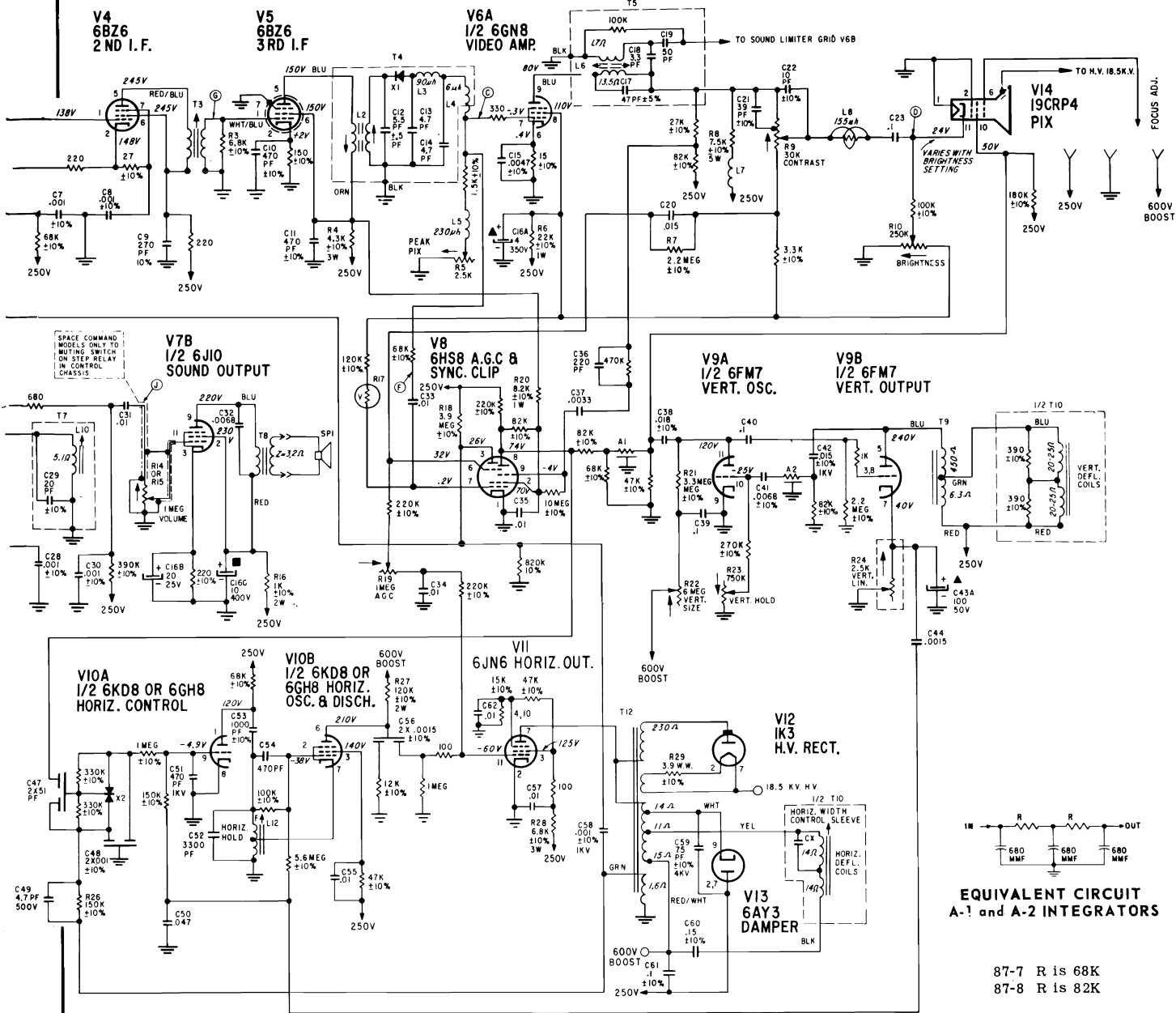

EQUIVALENT CIRCUIT A-1 and A-2 INTEGRATORS

87-7 R is 68K
87-8 R is 82K

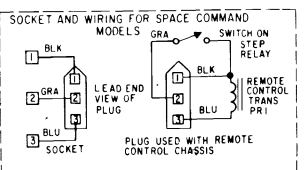
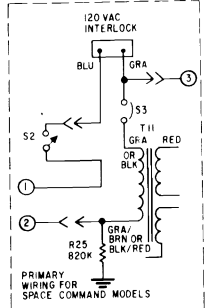

NOTES:
 ALL VOLTAGES MEASURED FROM CHASSIS TO POINTS INDICATED.
 ALL VOLTAGES ARE D.C. UNLESS OTHERWISE SPECIFIED.
 ALL D.C. VOLTAGES TO BE MEASURED WITH A VACUUM TUBE VOLTMETER HAVING 11 MEGOHM INPUT RESISTANCE.
 ALL VOLTAGE MEASUREMENTS TO BE MADE WITH NO SIGNAL PRESENT. NORMAL SETTING OF CONTROLS AND CHANNEL SELECTOR SET TO CHANNEL 2 UNLESS OTHERWISE SPECIFIED.
 ALL CAPACITOR VALUES IN MICROFARADS UNLESS OTHERWISE SPECIFIED.
 ALL CAPACITOR CAPACITY TOLERANCE ±20% UNLESS OTHERWISE SPECIFIED.
 ALL RESISTORS ARE ±20% TOLERANCE, CARBON, 1/2 WATT UNLESS OTHERWISE SPECIFIED.
 RESISTANCE MEASUREMENTS SHOWN WITH COIL DISCONNECTED FROM CIRCUIT.
 COIL RESISTANCES NOT GIVEN ARE UNDER ONE OHM.

ARROWS ON POTENTIOMETERS INDICATE CLOCKWISE ROTATION.
 CHASSIS INDICATES VOLTAGE SOURCE.
 PICTURE TUBE 2ND ANODE VOLTAGE TO BE MEASURED WITH ELECTROSTATIC KILOVOLT METER WITH BRIGHTNESS AND CONTRAST CONTROLS FULL COUNTER-CLOCKWISE.
 CX=CAPACITOR VALUE SELECTED FOR MINIMUM YOKE RINGING. VARIES WITH A RANGE OF 47 PF TO 72 PF (3 K.V., ±10%). WHEN NECESSARY, REPLACE WITH EXACT VALUE FOUND IN YOKE.
 CIRCLED LETTERS INDICATE ALIGNMENT AND TEST POINTS WHERE APPLICABLE.
 C - DETECTOR OUTPUT
 D - VIDEO OUTPUT
 E - I.F. AGC
 F - GROUND FOR I.F. ALIGNMENT
 G - 3RD I.F. GRID
 H - SOUND LIMITER PLATE
 J - SOUND OUTPUT
 K - SOUND DISC GRID

VOLUME TV-24, ADDITIONAL 1965 TELEVISION

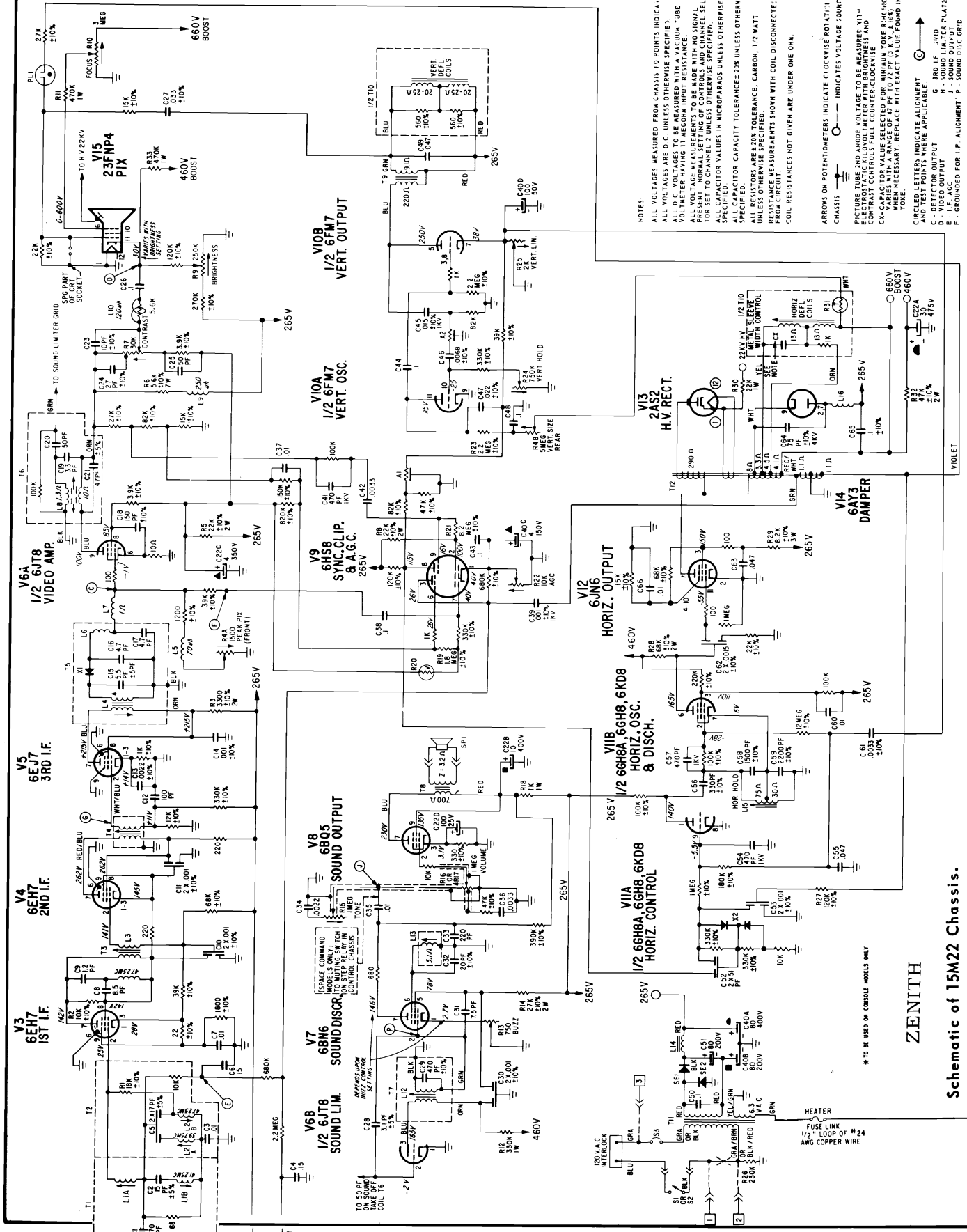

VOLUME TV-24, ADDITIONAL 1965 TELEVISION SERVICING INFORMATION

ZENITH Chassis 15M22 Service Information, Continued

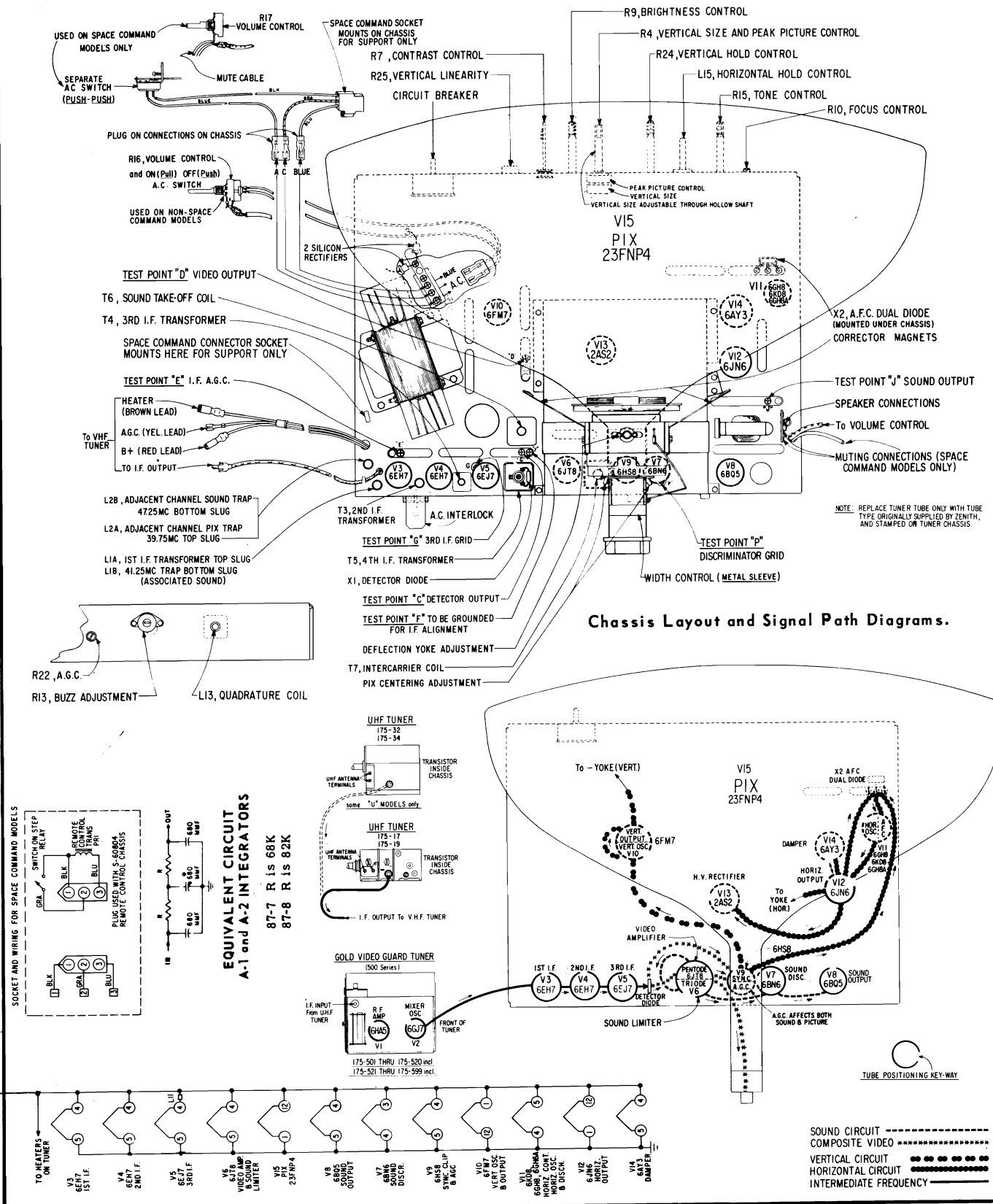

VOLUME TV-24, ADDITIONAL 1965 TELEVISION SERVICING INFORMATION

ZENITH Chassis 16M24 Schematic Diagram, Continued

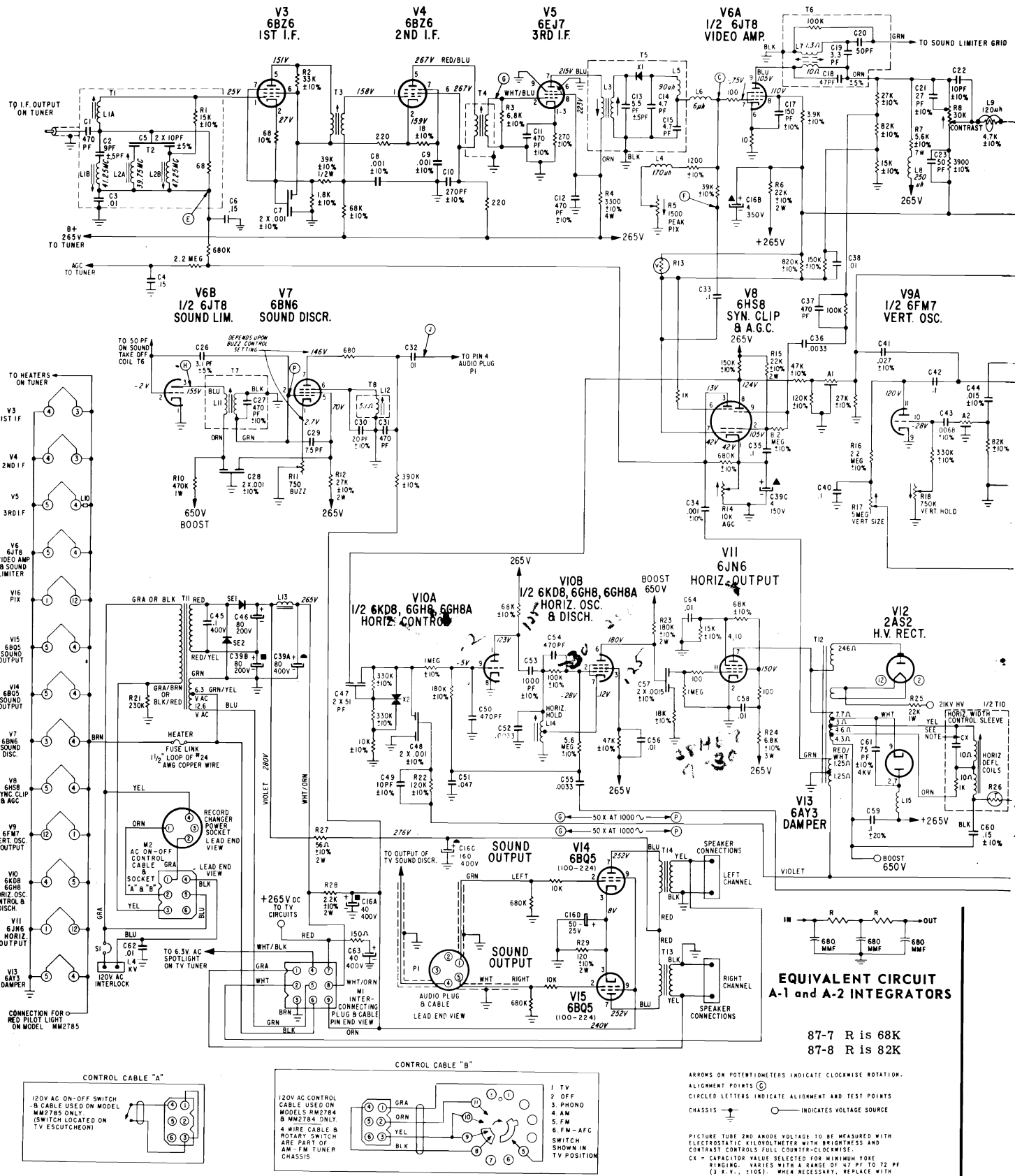

VOLUME TV-24, ADDITIONAL 1965 TELEVISION SERVICING INFORMATION

ZENITH Chassis 16M24 Service Information, Continued

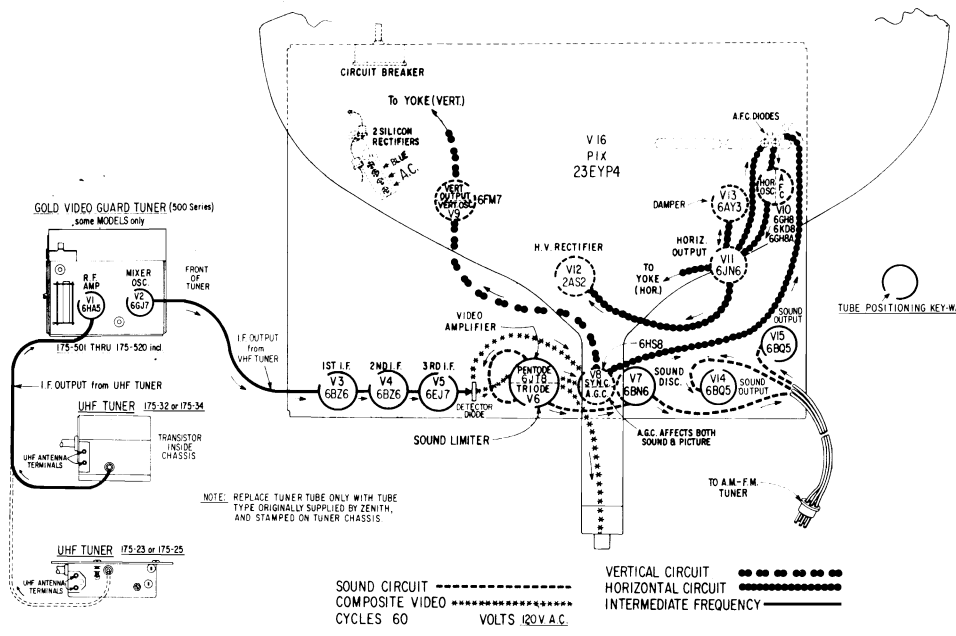
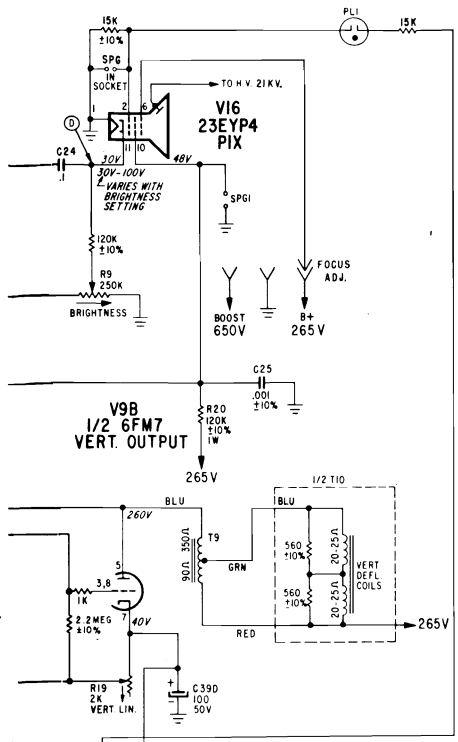

Schematic of 16M24 Chassis. Also, Chassis Layout and Signal Path Diagrams.

NOTES:
 ALL VOLTAGES MEASURED FROM CHASSIS TO POINTS INDICATED.
 ALL VOLTAGES ARE D.C. UNLESS OTHERWISE SPECIFIED.
 ALL D.C. VOLTAGES TO BE MEASURED WITH A VACUUM TUBE VOLTMETER HAVING 11 MEGOHM INPUT RESISTANCE.
 ALL VOLTAGE MEASUREMENTS TO BE MADE WITH NO SIGNAL PRESENT. NORMAL SETTING OF CONTROLS AND CHANNEL SELECTOR SET TO CHANNEL 2 UNLESS OTHERWISE SPECIFIED.
 ALL CAPACITORS VALUES IN MICROFARADS UNLESS OTHERWISE SPECIFIED.
 ALL CAPACITOR CAPACITY TOLERANCE ±20% UNLESS OTHERWISE SPECIFIED.
 ALL RESISTORS ARE ±20% TOLERANCE, CARBON, 1/2 WATT UNLESS OTHERWISE SPECIFIED.
 RESISTANCE MEASUREMENTS SHOWN WITH COIL DISCONNECTED FROM CIRCUIT.
 COIL RESISTANCES NOT GIVEN ARE UNDER ONE OHM.

NOTE: TO MINIMIZE HUM TV CHASSIS AND RADIO CHASSIS MUST BE TIED TOGETHER WITH GROUND STRAP FURNISHED IN CABINET ASSEMBLY

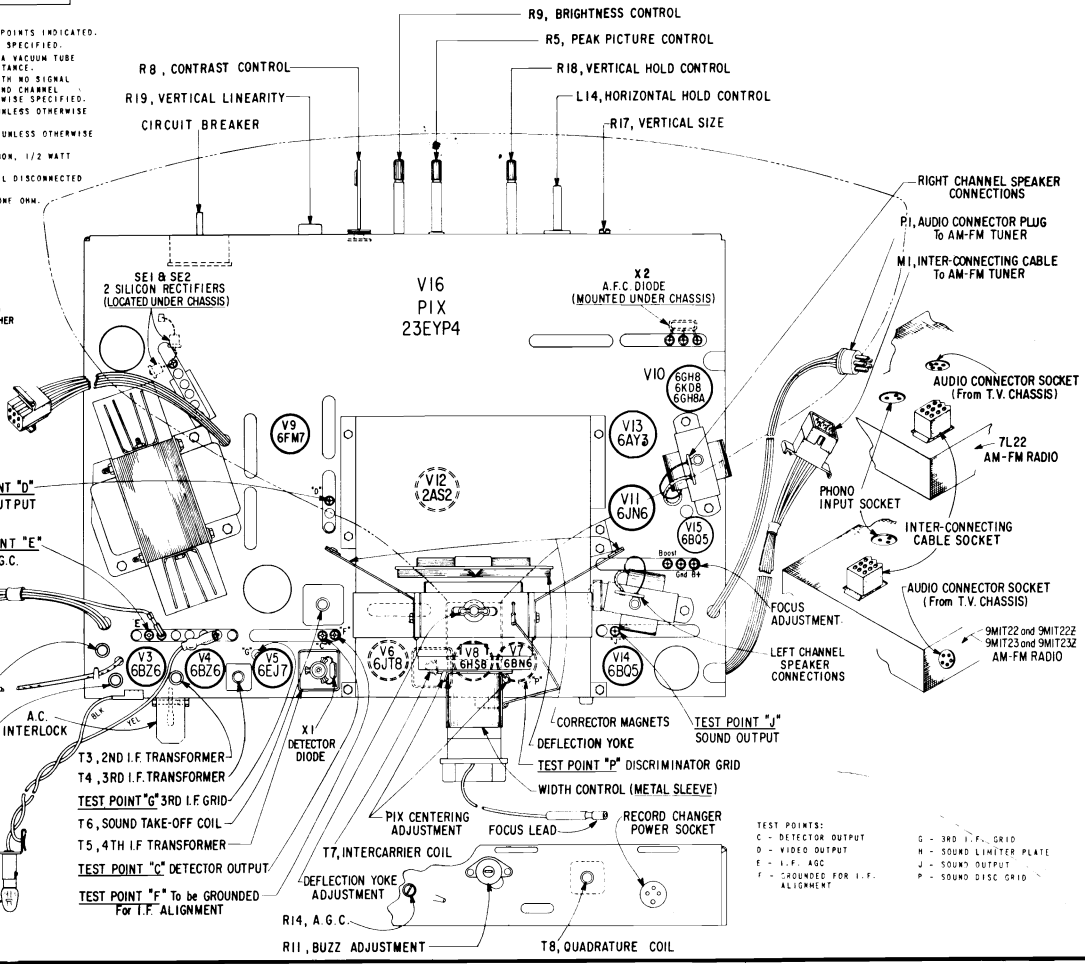

TEST POINTS:
 C - DETECTOR OUTPUT
 D - VIDEO OUTPUT
 E - I.F. A.C.
 F - GROUND FOR I.F. ALIGNMENT
 G - 3RD I.F. GRID
 H - SOUND LIMITER PLATE
 J - SOUND OUTPUT
 K - SOUND DISC GRID

INDEX

Under each manufacturer's name, at left there are listed that make chassis and models in numerical order. The corresponding page number at right of each listing refers to the first page of the section dealing with such material.

| | | | | |
|----------------------|-----------------------|----------------------|-------------------|----------------------|
| <u>Admiral Corp.</u> | <u>Admiral, Cont.</u> | <u>Delmonico</u> | <u>G.E. Cont.</u> | <u>Muntz TV</u> |
| 1D7 15 | PG2139 3 | TVM-11 23 | M415B++ 41 | 3210 79 |
| 1D760-1 15 | PG2144 3 | TVM-33 23 | TR803ABG 45 | 3211 79 |
| G6 3 | PG2149 3 | | TR805AEB 45 | 3311 79 |
| D7 15 | SMG3001 3 | | | 3411 79 |
| C21B12-1+ 9 | SMG3002 3 | <u>DuMont</u> | <u>Magnavox</u> | 3519 79 |
| C21C12-1+ 9 | TG3010 3 | 41P01 29 | 44 Series 53 | 3520 79 |
| C21C15-1+ 9 | CG3011 3 | 120746 29 | | 3521 79 |
| G610-2 3 | LG3011 3 | | | 3522 79 |
| G610-3 3 | TG3011 3 | | | 3523 79 |
| G612-1 3 | CG3012 3 | | | 3525 79 |
| G613-1 3 | LG3012 3 | <u>Emerson Radio</u> | | 4310 79 |
| G617-2 3 | TG3013 3 | 11P01 29 | <u>Montgomery</u> | 7310 79 |
| G620-1 3 | LG3015 3 | 11P02 29 | <u>Ward</u> | 7410 79 |
| G620-2 3 | LG3021 3 | 11P03 29 | GTM-2565A 155 | 7510 79 |
| G620-3 3 | TG3021 3 | 120746 29 | WG-2785A 59 | |
| D761-1 15 | LG3022 3 | 120788B 29 | GTM-2865A 147 | <u>Olympic Radio</u> |
| PD1124 9 | TG3022 3 | | WG-4515A 59 | 9P39U 85 |
| PG1129 9 | LG3025 3 | | WG-4545A 59 | 9P40,U 85 |
| PD1130 9 | TG3031 3 | | WG-4555A 59 | |
| PD1131 9 | LG3041 3 | | | <u>Philco Corp.</u> |
| PD1132 9 | LG3045 3 | <u>General</u> | | N1200 89 |
| PD1139 9 | LG3049 3 | <u>Electric</u> | | N1204 89 |
| PD1303 9 | LDU3445 15 | BY 35 | <u>Motorola</u> | <u>RCA Victor</u> |
| PD1304 9 | LDU3449 15 | DB 41 | 12BP70AA 85 | AF-020J 105 |
| PG1308 9 | LDU3461 15 | TA 45 | 12BP71AL 85 | AF-021E,+ 105 |
| PD1310 9 | LDU3465 15 | SAM332Y++ 35 | 12BP71A+ 85 | AG-029A,+ 105 |
| PG1310 9 | LD5001 15 | SAM334YM+ 35 | 19BP101A 73 | AF-045J 95 |
| PD1311 9 | LD5011 15 | SAM335Y++ 35 | 19BP103A 73 | AF-049E,+ 95 |
| PG1311 9 | LD5021 15 | SAM360Y++ 35 | 19BP104A 73 | AF-090E,H 95 |
| PD1312 9 | LD5025 15 | SAM361Y++ 35 | 19BP105A 73 | AF-095H,+ 95 |
| PD1319 9 | LG5201 15 | SAM362Y++ 35 | VTS-454 65 | AG-095++ 95 |
| PG1319 9 | LD5205 15 | SAM363Y++ 35 | WTS-454 65 | KCS-136X+ 100 |
| PG1320 9 | TG9728 3 | M401BEG 41 | TDTS-586Y 73 | KCS-142AA 95 |
| PG1322 9 | PG9734 3 | PAM401BWD 41 | WNDTS-586Y 73 | KCS-142AC 95 |
| PG1325 9 | PG9737 3 | M403B++ 41 | WZDTS-586Y 73 | KCS-142R 95 |
| PG1329 9 | PG9739 3 | M413B++ 41 | ZDTS-586Y 73 | KCS-142U 95 |
| PG2134 3 | PG9744 3 | R413B++ 41 | | |
| PG2137 3 | PG9749 3 | | | |

(Index continued on page 192)

VOLUME TV-24, ADDITIONAL 1965 TELEVISION SERVICING INFORMATION

INDEX Continued

| | | | | |
|-----------------------|---------------------|---------------------|----------------------|----------------------|
| RCA, Cont. | Sears, Cont. | Sony | Westinghouse+ | Zenith, Cont. |
| KCS-142XA 95 | 456.61461 120 | TV4-203UW 127 | H-P3032 147 | M2003++ 171 |
| KCS0152A 105 | 456.61466 120 | | H-P3035 147 | L2004++ 171 |
| KCS-152C 105 | 456.61467 120 | Sylvania | H-P3039 147 | M2005++ 171 |
| BF-211++ 100 | 456.61474 120 | 19P16-1 133 | H-P3040 155 | M2012+ 171 |
| BF-213E,+ 100 | 456.61475 120 | 19P19-1 133 | H-P3041 155 | M2014++ 171 |
| CF263M,W 100 | 456.61510 120 | 19P36-1 133 | H-P3250 147 | T2015++ 172 |
| CF265++ 100 | 456.61511 120 | 19P37 133 | H-P3255 155 | T2018++ 172 |
| CF270M,+ 100 | 456.61512 120 | 19P38 133 | H-P3256 155 | T2020++ 172 |
| CF273W 100 | 456.61513 120 | 19P39 133 | H-P3260 147 | T2028W,+ 172 |
| CF274L 100 | 456.61560 115 | 19P40 133 | H-K3690 147 | T2029+6 172 |
| CF276V,W 100 | 456.61561 115 | 19P41 133 | H-K3693 147 | T2030+6 172 |
| CF277C,+ 100 | 528.61340 120 | 19T30,-1 133 | H-K3780 147 | SA2032+U6 171 |
| CF315M,W 100 | 528.61341 120 | 19T31,-1 133 | H-K3781 147 | SA2034++ 173 |
| CF335M,+ 100 | 528.61450 120 | 19T32,-1 133 | H-K3782 147 | T2035WU4 173 |
| CF336M,+ 100 | 528.61451 120 | 23E01 141 | H-K3783 147 | T2036+U4 173 |
| CF339M,W 100 | 528.61452 120 | 23E02 141 | H-K3840 147 | T2044+U4 173 |
| CF341M,W 100 | 528.61453 120 | 23H20 133 | H-K3841 147 | T2045+U6 172 |
| CF343M,W 100 | 528.61454 120 | 23H30 133 | H-K4080 155 | M2109++ 171 |
| CF345W 100 | 528.61455 120 | 23L135-1 133 | H-K4081 155 | M2110+U 171 |
| CF347L 100 | 528.61460 120 | 23L144 141 | H-K4083 155 | M2127++ 171 |
| CF349V,W 100 | 528.61461 120 | 23L145 141 | H-K4182 155 | M2150++ 171 |
| CF351C,+ 100 | 528.61466 120 | 23L146 141 | H-K4183 155 | M2155++ 171 |
| CF355M,W 100 | 528.61467 120 | 23L159 133 | H-C5240 147 | H2200LU,+ 171 |
| CF356W 100 | 528.61474 120 | 23L160 133 | H-P8000 163 | M2210++ 171 |
| CF357L 100 | 528.61475 120 | 23L161 133 | H-P8001 163 | M2214LU 171 |
| CF359M,W 100 | 528.61480 120 | 23T105 133 | H-P8020 163 | M2231++ 171 |
| CF369M,W 100 | 528.61481 120 | 23T106 133 | H-P8021 163 | H2300LU,+ 171 |
| CF371W 100 | 528.61484 120 | 23T110 133 | | M2705++ 171 |
| CF373L 100 | 528.61485 120 | 23T111 133 | Zenith Radio | M2706++ 171 |
| CF375F,V 100 | 528.61510 120 | 583-1 | 14M20 171 | M2708++ 171 |
| | 528.61511 120 | through | 14M23 171 | M2717++ 171 |
| Sears, Roebuck | 528.61512 120 | 583-6 133 | 14M25 171 | M2733++ 171 |
| 5120 115 | 528.61513 120 | 584-1 | 14M27 171 | M2735++ 171 |
| 5121 115 | 528.61560 115 | through | 14M28 171 | M2736++ 171 |
| 5150 120 | 528.61561 115 | 584-7 133 | 14M29 171 | M2737++ 171 |
| 5151 120 | 529.61340 120 | 585-3,-4 133 | 14M30 171 | M2738++ 171 |
| 5152 120 | 529.61341 120 | 585-5 133 | 14M31 171 | M2742+U 171 |
| 5153 120 | 529.61450 120 | 589-1 141 | 15M22 171 | MM2780WU4 172 |
| 5154 120 | 529.61451 120 | 589-3,-4 141 | 16M24 171 | RM2780WU4 172 |
| 5155 120 | 529.61452 120 | | M1615++ 171 | MM2781+U4 172 |
| 5156 120 | 529.61453 120 | Westinghouse | M1620Y+ 171 | RM2781+U4 172 |
| 5157 120 | 529.61454 120 | V-2474-1 | T1978++ 171 | MM2782MU4 172 |
| 5158 120 | 529.61455 120 | through | T1981++ 172 | RM2782MU4 173 |
| 5163 120 | 529.61460 120 | V-2474-13 147 | T1982++ 173 | MM2784++ 171 |
| 5164 120 | 529.61461 120 | V-2475-1,4 155 | T1986+U 172 | RM2784+U 171 |
| 5165 120 | 529.61466 120 | V-2475-11 155 | T1989+U+ 172 | MM2785+U 171 |
| 456.61450 120 | 529.61467 120 | V-2475-12 155 | T1997+U 172 | M3311++ 171 |
| 456.61451 120 | 529.61474 120 | V-2475-13 155 | M2000C++ 171 | M3333+U 172 |
| 456.61452 120 | 529.61475 120 | V-2478-1,2 163 | M2001C+ 171 | M3350WU 171 |
| 456.61453 120 | 529.61510 120 | H-P3029 147 | M2001L+ 171 | M3352MU 171 |
| 456.61454 120 | 529.61511 120 | H-P3030 147 | M2002F+ 171 | M3355HU 171 |
| 456.61455 120 | 529.61512 120 | H-P3031 147 | M2002L+ 171 | S-60803 190 |
| 456.61460 120 | 529.61513 120 | | | S-60804 190 |

Another

Supreme Publications

Service Manual