



RADIO SERVICE NEWS

PUBLISHED - IN - THE - INTEREST - OF - RADIO - SERVICE - SALES - ENGINEERS

VOLUME X, No. 1

EDITORIAL OFFICES, RCA, CAMDEN, NEW JERSEY

MARCH, 1945

TELEVISION IS READY AS SERVICE TO PUBLIC

RCA Laboratories Official makes Assertion in the Light of "Cold Engineering Fact"

The stage is set and ready, technically, for the beginning of a regular television broadcasting service to the public, according to E. W. Engstrom, Research Director of RCA Laboratories.

The state of readiness of television, as he sees it, is evaluated in cold engineering terms, and he adds, "Those who feel that television is not ready and should, therefore, be delayed must obviously not use the same clear spectacle lenses of engineering appraisal through which I so clearly see this situation.

"Now, as at earlier times," explains Mr. Engstrom, "there are those who raise their voices in opposition, but today the industry in regard to television is as nearly united in its recommendations as it is practical to expect. Those who oppose speak of the need of further improvement and refinement and of the necessity, therefore, to use channels in a higher frequency portion of the radio spectrum.

"Although they do not say so, the end result of following their recommendations would be to delay television for a long time. I have been active in the research and engineering development of television for many years. I have participated in the planning and the coordination during the period of the growth of television from research status to its present-day maturity."

In substantiation of his views, Mr. Engstrom cites major advances in television research and development:

1. Research has been done on very efficient reflective-type optics especially suited for television projection. These are now satisfactory in performance and low-cost manufacturing is assured. Thus we may expect that early post-war production of television receivers will include projection types of excellent performance with pictures adequately large for home use.

2. Major increases are indicated in sensitivity of the iconoscope or camera tube. Research on this had progressed to the point where substantial sensitivity gains were in sight when war called a halt to television work. The progress made gives promise of a solution to this important phase of television broadcasting. To be able to televise all

(Continued on page 3, column 2)

MUSIC FOR MORALE



This dramatic photograph, just released by the U.S. Coast Guard, shows GI's listening to recorded music on a portable phonograph during the tense hours as their LCI pushed its way toward an enemy coast. Recorded music is being played on battle fronts to build morale and relax our fighting men at crucial moments.

GETTING HEP TO THE HYPER FREQUENCIES

By MERRILL GANDER
Field Supervisor, National Office
RCA Service Company

Recent advances in the design of radio and electronic equipment have been so rapid that newcomers in the field, and even the more technical group who have been closely associated with the work for several years, and who now are just beginning to feel pretty confident about their understanding of screen grid and cathode ray tubes, have been driven close to drunk in an attempt to phase themselves properly for a plunge into the mysteries of these new developments. The situation is further aggravated by the fact that these newer developments are still regarded as confidential, and little can be found in the trade magazines or technical journals or in text books on the subject.

Meanwhile, we stand by and watch our favorite, familiar concepts of current and voltage being discarded for such vague terms as gradient and curl. The words grid and plate are being forsaken for such sporting terms as "buncher" and "catcher."

Illustrative of these rapid technical developments is the exploration of the hyper-frequency region, at one time represented by a blank space on the frequency allocation charts. It is the purpose of this article to discuss briefly the develop-

ment of equipment and methods involved in hyper-frequency aerobatics.

Generation

Probably the greatest single obstacle which prevented the early application of these hyper-frequencies was the necessity for a power oscillator that would generate these frequencies with some measurable power and stability. It was determined pretty reliably that conventional vacuum tubes were applicable to frequencies only up to 750 Mc, and transit time effects thereafter became the critical factor. Tube structures had already become so small that they were expensive to manufacture, and almost impossible to keep production tolerances. Electrode spacing was made smaller, which reduced transit time, but limited the heat dissipation and

(Continued on page 2, column 1)

CORRECTION

In your RCA Television Service Notes you will find that Part #33340 Television Capacitor, used in models TT-5 and TRK-5, is listed at 50c . . . the correct price is \$2.00.

CURRENT POSITION OF RECEIVER TUBES

Demands for Total War Increase Sharply as Crisis Nears

CIVILIAN SUPPLY LIMITED

EDITOR'S NOTE: In a recent special message to RCA distributors, L. W. Teeparden, General Manager of the Tube and Equipment Department, discussed current developments and decisions affecting the availability of renewal receiving tubes. Since this message is of such vital interest, it is reproduced below.

His letter is being addressed to you in an attempt to give you as much advance information as possible as regards the current outlook on the availability of receiving tubes from RCA for civilian renewal purposes. At the same time we should like to review certain recent developments and the decisions they have prompted us to make affecting civilian renewal tubes.

"Long prior to Pearl Harbor, with the advent of the National Defense Program, RCA stated its policy—

"With RCA Victor National Defense comes first. By comparison, we hold nothing else important." The prosecution of the war continues to be our first responsibility.

"At a recent WPB Receiving Tube Industry Advisory Committee meeting, military representatives stated that more and more receiving tubes are immediately needed to replace battle losses and to support new equipment production schedules. To meet these requirements total industry production for military purposes must be increased. There is no question but that we at RCA should do our part in meeting these requirements.

"However, RCA receiving tube production is currently being limited primarily by labor availability, and increased production cannot be realized unless and until our working force can be increased. In spite of our continuing best efforts, and those of WPB and the War Manpower Commission, we have been unable to secure sufficient people to utilize fully our receiving tube production facilities. This means that tubes for civilian renewal purposes can be produced only at the expense of current military requirements.

"Consequently, in view of indicated military requirements, and in accordance with our stated policy, RCA's receiving tube production is being scheduled mainly for war purposes.

(Continued on page 3, column 3)

HYPER FREQUENCIES

(Continued from page 1, column 3)

power output and at the same time raised the inter-electrode capacitances, and a stalemate had been reached. In the conventional vacuum tube, as the electron leaves the cathode enroute to the anode, and passes through the mesh grid, it induces a voltage in the grid, since it is immaterial if the conductor is moving in a field or if the conductor is stationary and the field moves, in this case, the electron. As the electron leaves the grid and continues its course to the anode, a voltage of opposite sign is induced in the grid.

Transit Time Great Obstacle

At broadcast and communication frequencies, these two induced voltages are practically on top of each other and cancel, but at the hyper-frequencies, where the transit time may be an appreciable part of the cycle, these two induced voltages are considerably separated, and may be represented as a voltage impressed on the grid in phase with the signal voltage, resulting in lowered input impedance, less power output, less gain, and requiring considerably more power to drive the tube. In fact, most of these tubes required almost as much power to drive them as was realized out of the tube, and the net gain was very small and practically useless. It was found that if these transit time effects are not to be objectionable, the time required for the electron to go from the cathode to the anode should not occupy a period of time greater than one-tenth of the cycle of the incoming signal frequency.

Magnetron Solves Transmission Problem

Barkhausen and Okabe were probably the first to arrive at some sort of solution, their respective developments being the Barkhausen oscillator, and the magnetron. To these velocity modulated tubes were later added tubes employing resonant cavities. Because of its flexibility over a wide range of fre-

quencies, stability and efficiency and power handling capability, the magnetron still enjoys widespread use in transmission, while some form of cavity resonator tube usually is employed in receiver design. The positive grid oscillator of Barkhausen proved the least adaptable, since transit time effects still limited output and efficiency, and also varied as the applied voltages. Frequency was also affected by the applied voltage, tube structure and the external resonant circuit, resulting in too many variable factors. In this respect the magnetron enjoyed two distinct advantages:

1. The direct loss of electrons to the grid mesh did not exist.
2. The process of phase selection due to the many variables was eliminated.

The ideal magnetron is capable of 90% efficiency, and those in actual use frequently reach 60%. The frequency depends on the magnetic field, and if this is a permanent magnet, the only factor materially affecting frequency is the magnetron structure. To a much lesser degree, the tuning of the external resonant circuit will affect frequency, unless this has been incorporated in the tube itself as is usually the case in modern tube design. The magnetron then is essentially a fixed frequency device, affected to a small extent by the external magnetic field and anode voltage, which are both held constant.

Cavity Resonators as Detectors and Amplifiers

So far, neither the positive grid oscillator nor the magnetron have been capable of amplifying the hyper-frequencies, and function principally as power oscillators.

The more recently developed cavity resonator tubes are capable of amplification at these frequencies. This is due mainly to the fact that transit time effects, while required for tube operation, do not insert any critical time intervals comparable to a resonant circuit. The cavity resonances function in a manner nearly independent of the electron beam, so it is possible to excite one

resonator with a small signal and extract a much larger signal from a second. No magnetic field is required, and no extremely high anode voltages, usually a few hundred volts being sufficient. Cavity resonator tubes have been proved capable of practical applications as oscillators, amplifiers, modulators and detectors at these extreme frequencies. Unfortunately, their cost is very high. The cavity resonator can be considered the same innovation to hyper-frequencies that the triode was to broadcast frequencies years ago.

Enormous Progress Made in Early '30's

With the advent of these tubes, micro-ray transmission made enormous progress. The services pressed into use shortly afterwards included:

1. Radio landing beam station, entirely automatic, established in Templehof, Germany, 1931, on 50 cm.
2. 18 cm. communication in 1934 from Dover to Calais.
3. Micro-ray link from St. Ingleviert to Lymptue in 1933 on 17.4 cm.
4. Secret war applications on ship, shore and aircraft.

Transmission

Fortunately, transmitters at these frequencies usually employ only one or two tubes, and some associated "plumbing," making them very small and compact. In some instances the latter can be incorporated as part of the antenna. This eliminates long transmission lines, and piping R.F. through awkward

distances. The recent tendency is to connect the antenna directly to the oscillator tube through a quarter wave section of line (at 3000 Mc. about 1 inch.) This eliminates complicated "bazookas," harnesses, line matching sections and tuning stubs and plumbing. Some installations, however, due to reasons of security or vulnerability, space requirements or accessibility, make this nice arrangement impossible, and some consideration must be given to transmission lines at these frequencies.

Transmission Lines Unsulted

Ordinary transmission lines are totally unsuited. Early experiments attempted the use of parallel lines and coaxial sections, eliminated the bothersome supporting insulators for the inner conductor, using instead pairs of solid metal stubs a quarter of a wavelength long, spaced at intervals along the inner conductor. While insulator losses were thus eliminated, the quarter wave stubs represented infinite impedance at only one frequency, and the inner conductor losses were still objectionable.

A solution to the problem lay in the use of wave guides, which as the name implies, merely guide the waves from point to point through a small, hollow metal tube. This can be square, rectangular, circular, elliptical or even triangular, each cross section and proportionment of dimensions representing some particular mode of operation and resulting in some particular configura-

(Continued on page 4, column 1)

HYPER FREQUENCY ANTENNAS

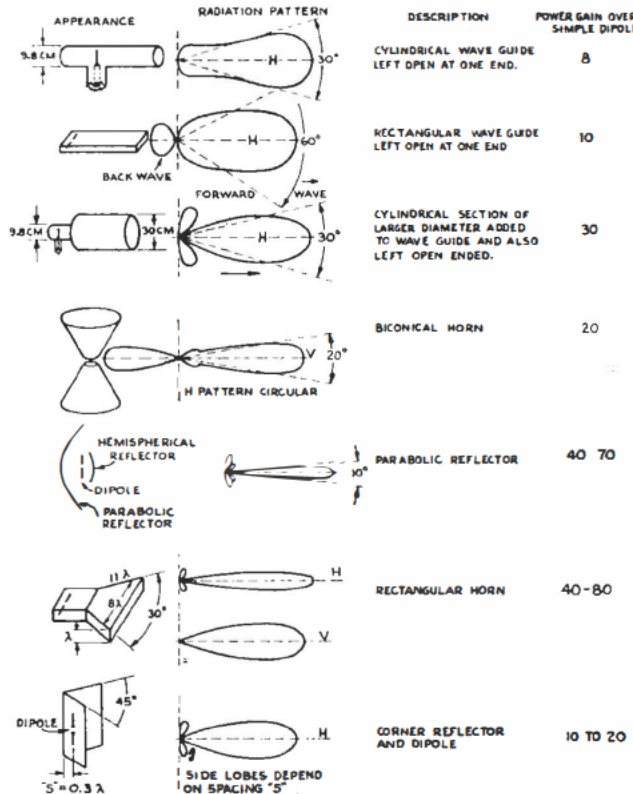

FIGURE 2

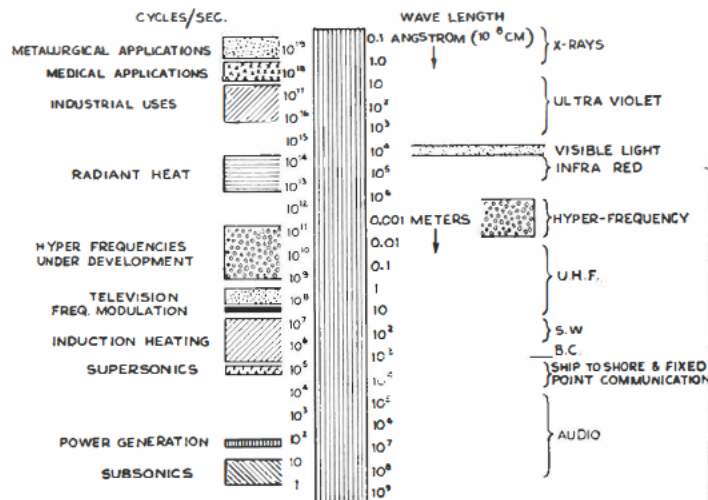

FIGURE 1

NEW FM RECEIVING SYSTEM OFFERS SUBSTANTIAL GAIN IN SELECTIVITY

RCA Victor Engineer Describes Developments at First National Electronics Conference

A high degree of freedom from noise and from interference from undesired stations in the reception of FM (frequency modulation) radio programs is made possible by a new advance in the design of FM receivers.

The new development, designated as a "frequency-dividing locked-in oscillator FM receiving system," is described in a paper by its inventor, George L. Beers, of the Radio Corporation of America.

"Frequency modulation," Mr. Beers points out, "is still in its infancy in terms of a nation-wide entertainment service. Until a large number of high-powered FM broadcasting stations are operating on a commercial basis, the major technical problems which are involved in the design of FM receivers will not be fully appreciated.

"Probably the most difficult requirement to be met is that of obtaining adequate adjacent channel selectivity. This problem was emphasized in a report on 'Blanketing of High Frequency Broadcast Stations' issued in 1941 by the Federal Communications Commission.

"This new FM receiving, in which a local oscillator is frequency-modulated by the received signal, represents a new approach to the problem. A substantial selectivity improvement has been obtained in the new system by designing the oscillator to lock-in only with frequency variations occurring within the desired channel."

Another important feature of the Beers system is a material improvement in the stability of the receiver from the standpoint of overall feedback. This results from the fact that the locked-in oscillator arrangement provides a substantial voltage gain at a different and lower frequency than the intermediate frequency employed in the receiver. High sensitivity is required in an FM receiver in order to obtain maximum performance. If this sensitivity is obtained at a single intermediate frequency, it is difficult to prevent overall feedback and provide satisfactory receiver stability.

"Basically," Mr. Beers observes, "the operation of the new system, on which a patent was recently granted, depends on producing, in the receiver, a local signal which is frequency-modulated by the received signal. The local signal is provided by a continuously operating oscillator. The received signal, after it has been amplified by conventional r-f and i-f amplifiers, is applied to the oscillator in such a way as to cause its frequency to change in accordance with the frequency variations of the received signal.



George L. Beers is a member of the engineering administration staff of the RCA Victor Division, responsible for the coordination of research and development. He is a member of both the television and frequency modulation panels of the Radio Technical Planning Board, and was a recipient of the Modern Pioneer Award of the National Manufacturers Association in 1940.

"In the particular applications of this system the oscillator is locked-in with the received signal at one-fifth of the intermediate frequency. With this 5 to 1 relationship between the intermediate frequency and the oscillator frequency, an equivalent reduction in the frequency variations of the local oscillator is obtained. Received signal frequency variations of plus or minus 75 kilocycles are reproduced as plus or minus 15 kilocycle variations in the oscillator frequency.

"It should be noted that the locked-in oscillator operating at one-fifth the intermediate frequency reduces the frequency deviation corresponding to any modulation frequency, but does not change the modulation frequency. The frequency-modulated signal derived from the oscillator is applied to a discriminator which is designed for this reduced range of frequencies."

TELEVISION IS READY

(Continued from page 1, column 1)

scenes which may be seen directly will add immeasurably to the immediacy and spontaneity of television programs.

3. Progress has been made and experience has been obtained using cable and radio methods for joining stations together in networks. We may look forward to a growth of networks suitable for television programs to support the growth of television broadcasting stations.

"At the war's end we will need all possible means of employment.

"Television can render a service which the public wants and needs, and at the same time provide employment for many."

TUBE SUBSTITUTION DIRECTORY CITED AS AID TO SERVICEMEN

The editors have received a letter of congratulation from Mr. J. M. Strong, of Radio Wire Television, Inc., in which the Tube Substitution Directory is warmly recommended as a tremendous help to the serviceman and even as an effective curb on black-market tube sales.

Commenting on its practicability, Mr. Strong said, "The Tube Substitution Directory, published by RCA, is really accomplishing things in the receiving tube field. It is putting into use many tubes which, heretofore, merely gathered dust. And, in addition to curbing black-market sales, it is helping the serviceman apply a little common sense in the use of a greater variety of tubes.

"The list itself," continued Mr. Strong, "has proved simple, easy to refer to and tells you what to substitute quickly. In the new field of tube substitution this directly is indicative of clear thinking offered to the serviceman to help him with his problems."

RCA's Tube Substitution Directory is still available. If you have not secured one, we suggest you contact your distributor without delay.

RECEIVER TUBES

(Continued from page 1, column 4)

poses. We will continue to so schedule our production until such time as either military demands diminish or we are able, through greater labor availability, to increase total production over and above military requirements.

"Through the 4th quarter of 1944, WPB has been directing the production and shipment of specified quantities of tubes for civilian

renewal purposes, but because of military requirements no such directive is expected for the 1st quarter of 1945.

"Previously the quantity of MR tubes for civilian renewal purposes we have been able to make available to you has been greatly dependent upon deliveries to us from other tube manufacturers under the interchange program sponsored by WPB. Under this program, which was intended to provide for the equitable distribution of available civilian tubes between manufacturers, RCA was scheduled to supply to its renewal tube customers substantially larger quantities than it was scheduled to produce, due to the fact that all but a very small proportion of our available production was requisitioned for war purposes.

"At a recent Industry Advisory Committee meeting in Washington on December 13, members of the industry recommended by a vote of four to three that the interchange program be discontinued. WPB accepted this recommendation. This means that, during the first quarter of 1945 at least, RCA will probably be unable to secure and make available to you tubes produced by other manufacturers for civilian renewal purposes.

"Consequently, after the MR civilian renewal tubes accumulated during December have been allocated in January, it is to be expected that the quantity of such tubes available from us will be drastically reduced.

"Obviously we regret the necessity for having to present this unfavorable outlook on the availability of civilian renewal tubes and we are conscious of what it means to you and your customers. On the other hand we are sure that you will understand our position, and agree with us that the first responsibility for us all is to do everything in our power to hasten the winning of the war."



"I'm testing the reception around here."

HYPER FREQUENCIES

(Continued from page 2, column 4)

tion of field within the guide. Unfortunately, one cannot merely connect a section of water pipe to the transmitter and expect any energy to be delivered to the antenna. Certain limitations and boundary conditions must be observed to satisfy Maxwell's equations for wave propagation.

Wave Guide Makes Appearance

The wave guide was first suggested as a solution, when an experimenter recorded the following results. A small dipole receiving antenna ($1\frac{1}{2}$ " at 4000 Mc) was placed about 6 ft. from a similar dipole attached to an oscillator of 4000 Mc. The receiving antenna was attached to a crystal detector and a millimeter. Little received energy was indicated by the meter, and placing a flat conducting sheet of copper at various places in an attempt to concentrate the energy fed to the receiving antenna had little effect.

The sheet was then rolled up into a cylinder, with the edges overlapping. When this was placed between the antennas, axially, it was noticed the energy indicated by the millimeter was off scale. For the frequency used, this occurred with a diameter of 4", and as the diameter of the cylinder was decreased to 2.25", the energy in the antenna dropped off to zero, sharply. This phenomenon was later verified mathematically, and explained as the "cut-off" frequency for that particular tube and mode of operation.

"Fields" Replace I and E Concepts

In further experiments, it was found that the time worn concepts of current and voltage in transmission circuits and the "go and return" circuits no longer existed, since there was no inner conductor. It was necessary to revert to early theoretical physics for many of the explanations of the system, which now involves the development and transmission of "fields."

It was also found that when these fields were investigated with probe meters and plotted, they no longer conformed to the theories expressed in electromagnetic wave theory. Another component appeared in addition to the normal components of electric and magnetic intensity, usually at right angles to the direction of propagation. This is either an electric or magnetic component in the direction of propagation, and is used to identify the mode of operation of a wave guide.

If a wave has a transverse component of magnetic field, and the electric field is resolved into two components, one radial and one along the axis of propagation, it is called a transverse magnetic wave. If the transverse component is electric and the magnetic field has two components, one radial and one in the direction of propagation, it is identified as a transverse electric wave, and all components of these fields are normal to each other. The theories and mathematics showing the development and how they

satisfied Maxwell's equations are not readily understandable, but evolve around certain elementary principles.

Seven Elementary Principles

1. A magnetic field results from the force exerted on a conductor by a current.
2. A changing magnetic field is capable of producing an electric field (curl).
3. A changing electric field is also capable of producing a magnetic field.
4. There can never be a discontinuity of magnetic field.
5. An electric field can terminate only on an electric charge.
6. A magnetic field can terminate only on a surface carrying a current.
7. These successive transfers of energy from one field to another result in a traveling wave of electromagnetic energy which must satisfy the general Maxwell equations.

Wave Guide Operation Characteristics

Briefly, wave guide operation can be summed up by the following characteristics:

1. Only a sine wave can pass through a wave guide without distortion. Any other wave becomes complicated, since it can be represented by Fourier series as a combination of sine waves of different harmonics and amplitudes, each passing through the guide with different velocities and attenuation.
2. Wave guides are not suited for frequency transmission below 1000 Mc. since their size would be prohibitive.
3. There is a minimum frequency below which the guide will not support oscillations, known as the frequency of cut-off.
4. The group velocity within the guide, which is the velocity at which energy is propagated along the tube, is always less than the velocity of light, but the phase velocity is always greater than light. A similar phenomenon occurs in optics, known as anomalous dispersion.
5. The lowest characteristic impedance of a circular guide is about 350 ohms, while a rectangular guide may be anywhere from 0-500 ohms.
6. The cylindrical guide has the lowest frequency of cut-off for the TM₀₁₁ mode of operation, being $8500/d$, where d is the diam, in inches, and the frequency is in megacycles.
7. H waves provide transmission of hyper-frequency waves with minimum attenuation, as low as 2DB/mile.
8. The TE₀₁ guide has the peculiar property of having less attenuation as the frequency is increased, although being less stable than any of the others.
9. Micro-wave transmission has also been accomplished through tubes of solid dielectric, as well as

RADIO ELECTRIC SERVICE OPENS NEW BRANCH



The Radio Electric Service Company, operating branch stores in Allentown and Philadelphia, Pa. and in Wilmington, Del., announced the opening of a new branch store at 513-15 Cooper St., Camden, New Jersey. The company's main offices are located at 7th & Arch St., Philadelphia, Pa. Mr. John Stern is president and Mr. Morris Green, vice president.

Mr. Joseph Berman has been appointed manager of the new branch which carries a complete line of stock, including vacuum and washing machine parts, public address, amateur and test equipment.

columns of water and through ordinary hose, although no immediate application of these experiments is indicated.

Antennas

Due to the small powers available at these frequencies, micro-wave transmissions usually employ highly directive devices as antennas, which conserve power by compressing the energy into a narrow beam. In addition, since these waves are optical in nature, for reliable communications links, an attempt is made to place the transmitting and receiving antennas as far above earth as possible and in "line of sight" of each other.

Prior Antenna Types Unsuitable

Obviously, simple dipole antennas, multiwires, and stacked

arrays are not readily suited. Simple dipoles using corner reflectors were first tried with some success. Later, the same dipole using parabolic reflectors were quite popular, and more recent still, horn antennas seem to be the last word in hyper-frequency antenna design. The parabolic antenna with simple dipole presents a simple termination when some other form of transmission line is used, but for wave guide transmission, a horn is readily adaptable.

As a receiving antenna, the horn will absorb a much greater amount of energy from a wave in the favorable direction than any other antenna, and in addition, is practically free from disturbing side lobes in the H or V plane. These antennas are shown in Figure 2.



Linda Darnell, star of the picture "Goodbye My Love," strikes a sultry pose in the above scene released thru United Artists.

Replacement Parts Section — Announcements, Tips, Suggestions

SALES AND SERVICE TIPS

You can win a handsome RCA Service Engineer's Pencil by sending tips to RCA RADIO SERVICE NEWS, Camden, New Jersey. All tips become the property of RCA to use at its discretion. Service Tips are our readers' ideas, not ours; while we believe they are worthwhile we cannot be responsible for results.

SUBSTITUTING THE 12K7GT IN MODELS VHR-207, 307, 407

When a 12K7GT tube burns out the receiver becomes inoperative, due to the high bias developed in the bias voltage divider network.

If a replacement is not available a substitution can be made to restore operation, as follows:

Break the glass and clean out the base of the defective tube (or any octal base tube) and wire in a resistor (approx. 84 ohms, 5 watt) connecting it to pins #2 and #7. Insert this adapter in the 12K7GT socket. Tape up the top cap connecting lead to prevent accidental shorting of bias cells.

The microphone is not useable when using this adapter.

When replacing the 12K7GT tube use one having a metal base shell. If one is not available, connect a flexible ground lead from the tube shield to chassis.

S. F. PUSEY,
Madera, Penna.

RCA DUAL CONTROLS ARE ADAPTABLE TO MAJESTIC

RCA stock #31366, dual controls, can be adapted to Majestic models 2C60, 2C60P and 7C75 by cutting the inner and outer shafts to size.

For the Majestic 2C60P, connect a 45,000 ohm 1/4 watt resistor from the high side of the volume control section to the bass compensating tap. Connect a 50,000 ohm 1/4 watt resistor from the low side of the volume control to the bass compensating tap.

Since no compensating taps are used on the Majestic 2C60 and 7C75, merely shunt the control with a 1/4 watt resistor of 500,000 to 750,000 ohms.

The tone control section is wired in the usual manner.

JOHN N. BOOJAMRA,
474 Forty First St.,
Brooklyn 32, N. Y.

CHECK SOCKET CONTACTS TO FIND INTERMITTENTS

This service tip simply adds to the present store of devices presently in use for locating intermittents, but to prevent call-backs and to save time, we have adopted the following as standard practice for our shop.

After every repair job is ready for final inspection we move each tube about in its socket to show up poor socket contacts as well as poor lug connections.

The Wright Radio Service
1602 Charles Street
Springfield, Ohio.

HOW TO REPLACE 12 VOLT WITH 6 VOLT TUBE

Tubes of the six volt series may be used in sets using twelve volt tubes by removing filament wires on socket in which tube is to be replaced and connecting a 40 ohm, 5 watt resistor in place of the tube. The AC line that connects to the 35Z5 filament is disconnected from the 35Z5 socket and connected to one filament terminal of the socket in which the tube is being replaced. Wire is then connected from other filament terminals of socket in which tube is being replaced, to the 35Z5 socket terminal from which the AC lead was removed.

Sets take more time to heat but work okay.

E. H. TOMES,
600 E. Jefferson Ave.,
Detroit, Mich.

EDITOR'S NOTE: While the method shown in the RCA Substitution Directory is to be preferred—for it requires less circuit revision and provides better operating efficiency—Mr. Tomes' system does have the advantage of requiring but one small resistor. Careful wiring is very important, however, since hum may be introduced if the heater leads are not properly dressed. Note that, if it is more convenient, the six volt tube may be connected in the grounded AC lead instead of the AC lead to the 35Z5 heater.

INSPECT CONDENSER FOR DISTORTED TONE IN V-135

In recently servicing the model V-135, we found that distorted tone quality is commonly due to C-17 820 MMFD condenser leaking.

We call this to your attention because of the rare occasions that a Mica condenser will cause trouble. This condenser, upon inspection, revealed that it had considerable leakage.

A. HUGHES,
Krich-Radisro, Inc.
422-432 Elizabeth Ave.,
Newark, N. J.

TACK LIFTER AIDS IN REMOVING NUTS

I have found the following a useful and practical idea.

Sometime the machine screws holding the speaker to the console will turn when the nuts are being removed. Using a tack lifter that has a V slot in it, slip the V end under the nut and press it against the screw. This will hold the screw and the nut can then be removed easily.

SHERMAN M. WOLF,
372 Tremont St.,
Boston 16, Mass.



"Time out for a breather." These four little gals pause long enough to give you an eye-filling preview of the United Artists' production, "Sensations of 1945."

STONE COMPENSATION

Because of the widely varying frequency characteristics of several types of audio amplifiers which may be used, it may be desirable in some cases to make refinements in the pickup circuit of the crystal pickups to compensate for the characteristics of the amplifier. The following circuits show means of making such refinements.

In Figure 1, R1 controls the low-frequency response; larger values of R1 give increased lows. For maximum low-frequency response, remove R1. R2 controls pickup output, smaller values of R2 giving increased output. C1 controls high-frequency response; to increase highs, increase C1.

Where a decrease in high-frequency response may be desired (for example, as an aid in reducing "needle scratch" on worn records), the circuit in Figure 2 is applicable. In this circuit, C2 acts as loading on the pickup and is also a controlling factor on the high-frequency response. Smaller values of C2 give more pickup output and also more highs. R3 gives a sharper high-frequency reduction; increasing R3 decreases highs.

WET ELECTROLYTIC CAPACITORS NO LONGER AVAILABLE

Stock on Wet Electrolytic Capacitors RCA 5212, 11203, 11495, 14775, 31753, etc. is exhausted and from present indications the Wet Electrolytic type of capacitors are considered obsolete by the trade and will not be manufactured in the future.

It will be necessary to use Vee-line Capacitors, ear mounting or similar types for servicing sets requiring this kind of capacitor. It is advisable to select a unit of slightly higher capacitance when substituting a dry electrolytic capacitor for a wet one.

The wet type electrolytic has lower RF impedance which will cause hum in some circuits. A fixed paper capacitor (of approximately .1 mfd. rating) connected across the electrolytic will generally eliminate any excessive hum caused by capacitor changeover.

The suggested values shown in Figure 2 should serve as a basis from which slight alterations may be made to suit individual cases.

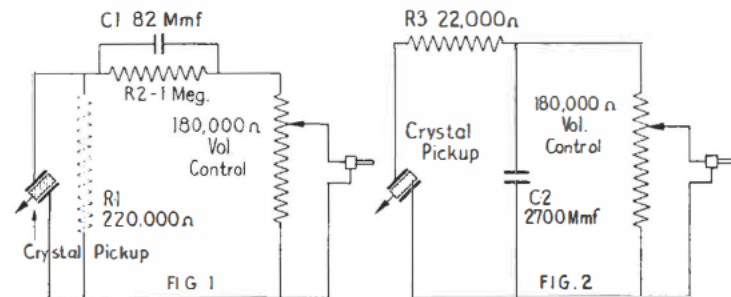

EXCESS STOCK SECTION

Permanent Magnet Type Speakers

Stock No.	Dia.	Weight Magnet	V.C. Imp. at 400 cy.	Output Trans.	Output Tube	List Price*
70105	5"	10 oz.	4 ohms	No	\$6.40
70107	5"	3½ oz.	4 ohms	No	3.56
70177	5"	6 oz.	4 ohms	Yes	6V6	6.27

Excess FP-Type Dry Electrolytic Condensers

Stock No.	Capacitance	Diameter	Length	List Price (Each)
37443	20 Mfd. 400 Volts	1"	2"	\$1.45
37444	20 Mfd. 25 Volts 20 Mfd. 350 Volts 5 Mfd. 300 Volts 20 Mfd. 25 Volts	1"	2"	1.45

Excess Volume Controls

Stock No.	Value	Tap	Shaft	Switch	Instrument	Remarks
33425	250,000	60,000	2 3/16	SPST	K60, K80	
36242	500,000	No	1 1/8	SPST	15X, 16X1, 16X2, 16X3, etc.	50,000 ohms Min. RCA Std. Shaft
38409	500,000	No	2 1/2	No	28X, Q27, VHR212, Q22 Q25, etc.	RCA Std. Shaft
36495	1 meg.	No	15/32	No	BP10	
70064	1 meg.	200,000	2	SPST	
37992	1 meg.	200,000	2 3/8	SPST	QU51	
38401	2 meg.	2 1/2	No	RCA Std. Shaft
70066	2 meg.	400,000	2 3/8	SPST	
34721	2 meg.	500,000	1 11/32	SPST	U40, U42, U20	
34695	2 meg.	500,000	2 3/16	SPST	K60A, K80A, K81A, etc.	

All controls have contact arm insulated from shaft.
All controls have log curve.

OUTPUT TRANSFORMERS

Stock No.	Turns Ratio	V.C. Imp. at 400 Cy.	Output Tube	Suggested List Price
70256	39.4:1	4	2A5	\$1.44
6709	59.2:1	4	Push Pull 30's	1.39

Approximate Formulae for finding Primary Load Impedance of a Transformer knowing the turns ratio and Voice Coil Impedance.

$$\frac{\text{Turns Ratio Squared} \times \text{V.C. Impedance}}{\text{Efficiency}} = \text{Primary Load Impedance}$$

(*) Transformer Efficiency

(*) For Transformer Efficiency use 85%.

For example: $\frac{39.4^2 \times 4}{.85} = 7,305 + \text{Approximate Plate Load Impedance}$

PARTS AVAILABLE

Stock No.	Description	Suggested List Price
5223	Volume Control for C15-2, C15-3, D22-1	\$1.50
9632 (*)	Universal Audio Transformer	2.00
14863	Switch, Tone and Power for 813-K, 816-K	1.10
31413	Volume and Tone Control and Power Switch for 96T, 96E, 95T5, 97X, etc.	2.50
34563	Ballast Resistor Tube for CV-40	.80
37681	Cord—Resistance Power Cord (545 ohms)	1.00
70041 (**)	Cone Diaphragm less voice coil for RL-79 type speaker	.20
Y-806	Cabinet—This cabinet may be used as an alternate for Y-807 (Ivory) for models 45X2 and 45X6.	

(*) Only limited stock available. (**) Used with 3/4 Voice Coil Assembly RCA 70075. Stock is depleted on RCA 70075.

EXTERNAL ANTENNA COUPLER FOR LOOP RECEIVERS

A specially designed antenna coupler, Stock No. 9912 is available for use in connecting an external antenna to a loop receiver. This coupler will prove valuable for installations where it is desirable to eliminate the loop in order to improve the signal noise ratio and increase sensitivity.

The antenna coupler may also be used as a fixed-tuned substitute for any standard loop antenna to aid in aligning loop receivers in a shop. The coupler covers "A" and "B" bands, approximately 550 to 1,750 kc, and 1,750 to 5,000 kc. It has low-frequency and high-frequency adjustments on each band to ensure adaptability and good performance on practically any loop receiver. Suggested List Price of RCA 9912 is \$2.25.

REPLACEMENT PHONOGRAPH MOTOR STILL AVAILABLE

Motors and necessary parts to replace the original motors in RCA Phonograph instruments U-125, U-126, U-128, U-130, U-132, U-134, etc. are still available.

These motors have proved to be an excellent replacement for the original motors and the regularity of sales indicates many servicemen are making use of this changeover kit.

The list of parts required to replace RCA motors, stock numbers 31157 and 31163 (110-V, 60-cycle) is as follows:

Part	Suggested List Price
1—RCA No. 38567 Constant Speed Motor 105-125 V.—60 cycles	\$6.80
1—RCA No. 38568 Thrust Bearing Assembly	0.60
1—RCA No. 38569 Motor Support Plate	0.60
Total	\$8.00

INSTALLATION

- Remove original motor and support plate assembly from instrument.
- Drive out TAPERED COUPLING PIN and lift turntable and spindle assembly from mechanism.
- Install Stock No. 38568 Thrust Bearing assembly; consisting of two ground steel washers, one felt washer and ball bearing, as illustrated. Apply slight amount clean oil to this assembly.
- Attach coupling to spindle with TAPERED PIN.
- Mount motor and support plate, being certain to precisely align turntable spindle and motor shaft. Improper alignment will produce "Wow."
- Mesh the flexible coupling as illustrated—same as original arrangement. If rubber strips are worn or deteriorated, replace them using RCA Stock No. 31147.
- Connect leads same as for original motor.

GENERAL

- Motor No. 38567 is a shaded pole-induction type similar to that used on RP-139 record changers. Speed is non-adjust-

SUBSTITUTE FOR RCA 36331 FIELD COIL

Stock is exhausted on RCA 36331 Field Coil and at the present time it is impossible to replenish the supply. Use of RCA Field Coil 37104 as a substitute is suggested until the original coil is again available. This substitute coil is the same physical size as the original but the resistance value is only 1250 ohms in contrast to the 36331 coil which has a value of 1630 ohms DC. Therefore, when using the 37104 as a substitute it will be necessary to add a 400 ohm, 5 or 10 watt resistor in series with the 1250 ohm field for satisfactory operation and to avoid damage to the circuit.

RCA 36331 Field Coil is used in RCA Speakers RL70M2, M3, M4, N3 and N6.

The suggested list price for the RCA 37104 coil is \$3.00 each.

STANDARDIZED NEEDLE SCREWS FOR CRYSTAL PICKUPS

Standardization has been announced on three (3) sizes of needle screws for RCA Crystal Pickups. These pickups were illustrated on page 8 of the June, 1944 RADIO SERVICE NEWS (figures 3 to 13, inc.).

Part	Suggested List Price
RCA 31160—#1-72 THD. 25/32" Long	\$0.10
RCA 33974—#1-72 THD. 1" Long	.10
RCA 38196—#1-72 THD. 1 3/32" Long	.10

able. Speed tolerance for extreme voltage and load conditions: 77-81 RPM Replacements:—FIELD COIL—No. 32954; Spindle and gear—No. 38597.

- Remove lower steel washer from thrust bearing assembly if turntable tends to be too high, or DRIVE GEAR does not mesh properly.
- If mechanical hum is experienced, check flexible mounting of support plate; loosen if necessary. Cushion-mount motor if adjustment of the plate is ineffective.

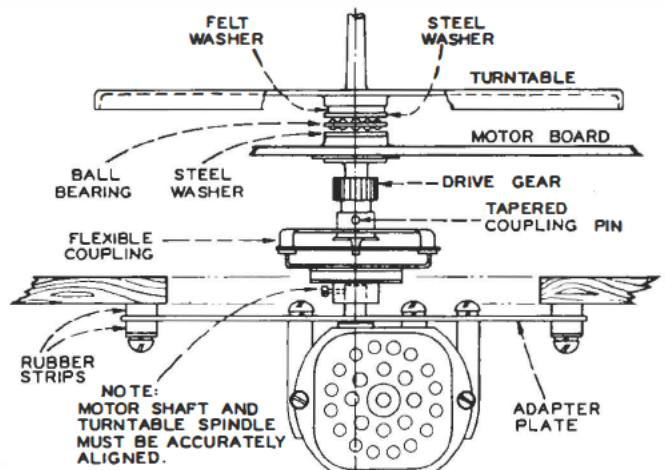

Method of Installing Replacement Phono Motor No. 38567

RCA CERAMIC CAPACITOR COLOR CODING

METHOD I

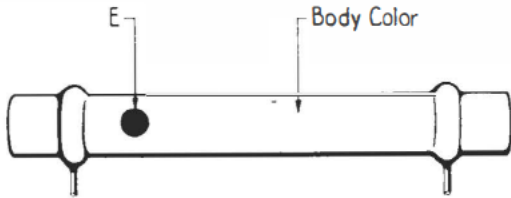

Capacity mmfd.	Tolerance	Dot E	Body Color
34	±2½%	Red	White
37	±3%	Brown	Dark Green
43.5	±3%	Red	Dark Green
50	±2½%	Orange	Cream
120	±2%	Blue	Dark Green
150	±5%	White	Dark Green
100	±5%	Yellow	Dark Green

METHOD II

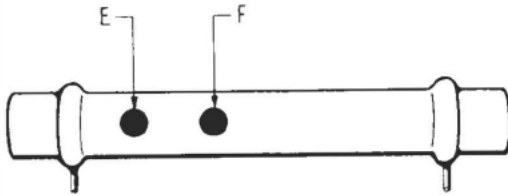

Capacity mmfd.	Tolerance	Dot E	Dot F
4.7	±0.5 mmfd.	Brown	Brown
4.7	±10%	Brown	Red
5.6	±0.5 mmfd.	Blue	Blue
8.2	±0.5 mmfd.	Orange	Orange
8.2	±0.5 mmfd.	Yellow	Blue
10	±0.5 mmfd.	Blue	Orange
10	±5%	Brown	Orange
12	±5%	Brown	Yellow
15	±5%	Brown	Blue
15	±10%	White	Orange
18	±5%	Brown	White
22	±5%	Red	Orange
27	±5%	Yellow	White
33	±10%	Red	Yellow
39	±2½%	Blue	White
39	±2½%	Red	Brown
39	±10%	Blue	Red
47	±2½%	Red	Blue
47	±2½%	Blue	Yellow
47	±10%	Red	White
56	±2½%	White	White
56	±2½%	White	Brown
68	±10%	Orange	Yellow
80.5	±1.0 mmfd.	Yellow	Yellow
82	±2½%	Orange	Blue
82	±2½%	Red	Red
82	±10%	White	Gray
85	±1.0 mmfd.	White	Red
215	±2½%	Orange	White

METHOD III

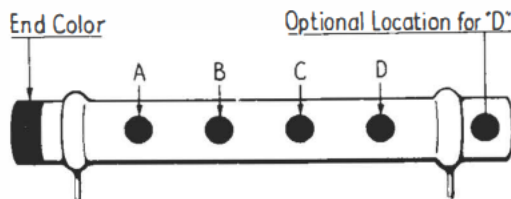

Color	Capacity mmfd.			Tolerance Values		Temper. Coefficient of Capac. mmfd./mmfd./°C.
	First Digit Dot A	Second Digit Dot B	Multiplier Dot C	For Capacities Greater than 10 mmfd. Dot D	For Capacities of 10 mmfd. or less Dot D	
Black	0	0	1	0
Brown	1	1	10	±1%	±0.1 mmfd.	0.3(10) ⁻¹
Red	2	2	100	-0.8(10) ⁻¹
Orange	3	3	1,000	-1.5(10) ⁻¹
Yellow	4	4	10,000	2.2(10) ⁻¹
Green	5	5	±5%	±0.5 mmfd.	3.3(10) ⁻¹
Blue	6	6	4.7(10) ⁻¹
Violet	7	7	.001	-7.5(10) ⁻¹
Gray	8	8	.01	±2½%	±0.25 mmfd.
White	9	9	.1	±10%	±1.0 mmfd.

HOW TO IDENTIFY

RCA Type No. 165 and 165A Junior VoltOmyst Meters

Wartime conditions have made it necessary to use a variety of meter types. Therefore, when ordering complete meters or meter case fronts check carefully all the identifications given below. In most cases the type, code and serial number will be found stamped on the bottom of the VoltOmyst. Note that meter glass is supplied only complete with meter case front.

Information	Code	Stock Number
Note number 7090 on dial scale. Note fluting center and sides.	Code 1142	
	Code 243-S	Complete Meter... 43923
	Code 943	Meter Case Front. 44288
Note number Z-15.1102A on dial scale. Note fluting center only.	Code 1142	Complete Meter... 45931
	Code 243-D	Meter Case Front. 45934
Note "step" edge around entire case. Note movement is covered.	Code 1142	Complete Meter... 47158
	Code 243-B	Meter Case Front. 47159
Note "step" edge. Note open face with movement visible.	Code 113-B:	
(Meter has one large and two small mounting studs.)	Code 913:	
(Meter has three 6-32 mounting studs.)		Complete Meter: Replace with... 43923 Meter Case Front. 47034
Note 15° corners. Note condensed arc on scale.	Code 143	Complete Meter... 47146 Meter Case Front. 47155

EXAMPLES

METHOD I	METHOD II
43.5 mmfd. ±3%	80.5 mmfd. ±1.0 mmfd.
Red	Yellow
Dark Green	Yellow
METHOD III	METHOD III
8.2 mmfd. ±0.5 mmfd., temperature coefficient 0 mmfd./mmfd./°C	220 mmfd. ±10%, temperature coefficient 7.5(10) ⁻¹ mmfd./mmfd./°C
Black	Violet
Gray	Red
Red	Red
White	Brown
Green	White

NOTES ON COLOR CODING

Published for the first time, here is a schedule of RCA ceramic capacitor color coding. This information has been compiled from engineering and standardization data and should prove of great value to the distributor, dealer and serviceman.

**PREFERRED
TYPES**

RADIOIRON

RCA

RADIO TUBE
A QUALITY PRODUCT
made by
RCA

RCA

PREFERRED BY THE SERVICES
PREFERRED IN OUR SERVICE WORK*

Preferred Type **TUBES**

*RCA DEVELOPED AND INTRODUCED MORE TUBES ON THE JOINT ARMY-NAVY PREFERRED LIST OF VACUUM TUBES THAN ANY OTHER MANUFACTURER

PUT THIS GAL TO WORK

Let HER sell your customers the idea . . . quality tubes mean quality service.

Let people know you are actively in business and are there to stay.

Get your Preferred Type Display from your RCA distributor . . . today